

CENTRAL BUSINESS DISTRICT (CBD) TOLLING PROGRAM

Appendix 4B.2, Transportation: Traffic Flow Maps

2023

CBD Tolling
9A - Traffic Flowmap
AM Existing



- Legend:**
- ① - Intersection (2019 Collected Data)
 - ⑦ - Intersection (Uncollected Data)
 - 100 - ATR Volume
 - 100 - Approach Volume

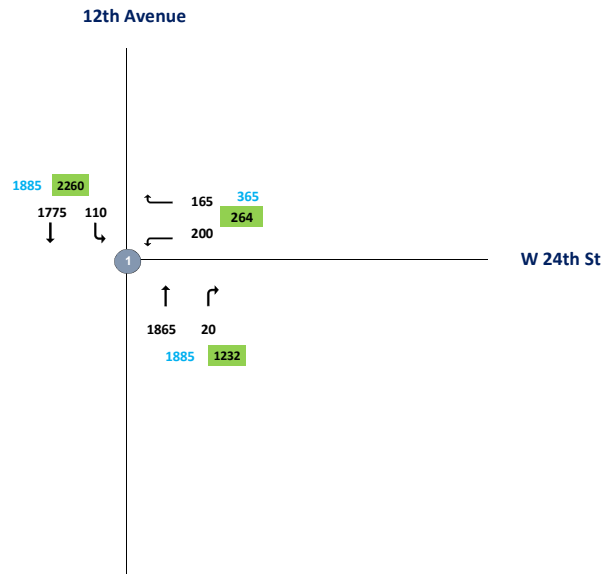

9A

8:00 AM

Intersection	Node	Approach	Total Vehicles					
			Inbound/Outbound					
			AM Peak Hour					
			L2	L	T	R	R2	Total
12th Ave & 24th Street 2019 (TMC-065)	1							
24th Street	1	EB	0	0	0	0	0	
24th Street	1	WB	0	200	0	165	0	
12th Ave	1	NB	0	0	1865	20	0	
12th Ave	1	SB	0	110	1775	0	0	4135

CBD Tolling
9A - Traffic Flowmap
MD Existing



- Legend:**
- ① - Intersection (2019 Collected Data)
 - ⑦ - Intersection (Uncollected Data)
 - 100 - ATR Volume
 - 100 - Approach Volume

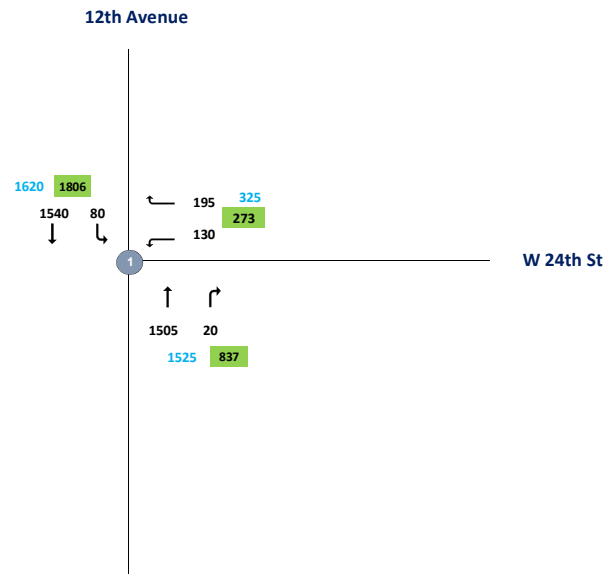

9A

1:00 PM

Intersection	Node	Approach	Total Vehicles					Total
			Inbound/Outbound					
			MD Peak Hour					
			L2	L	T	R	R2	
12th Ave & 24th Street 2019 (TMC-065)	1							
24th Street	1	EB	0	0	0	0	0	
24th Street	1	WB	0	130	0	195	0	
12th Ave	1	NB	0	0	1505	20	0	
12th Ave	1	SB	0	80	1540	0	0	3470

CBD Tolling
9A - Traffic Flowmap
PM Existing



- Legend:**
- ① - Intersection (2019 Collected Data)
 - ⑦ - Intersection (Uncollected Data)
 - 100 - ATR Volume
 - 100 - Approach Volume

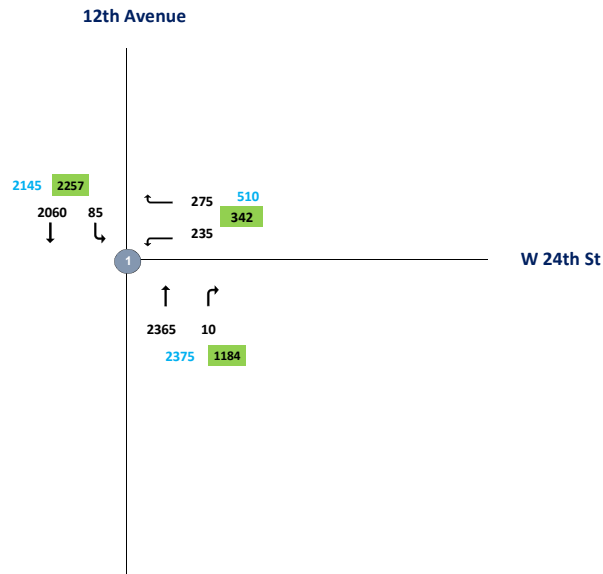

9A

5:00 PM

Intersection	Node	Approach	Total Vehicles					Total
			Inbound/Outbound					
			PM Peak Hour					
			L2	L	T	R	R2	
12th Ave & 24th Street 2019 (TMC-065)	1							
24th Street	1	EB	0	0	0	0	0	
24th Street	1	WB	0	235	0	275	0	
12th Ave	1	NB	0	0	2365	10	0	
12th Ave	1	SB	0	85	2060	0	0	5030

CBD Tolling
9A - Traffic Flowmap
LN Existing



- Legend:**
- 1 - Intersection (2019 Collected Data)
 - 7 - Intersection (Uncollected Data)
 - 100 - ATR Volume
 - 100 - Approach Volume

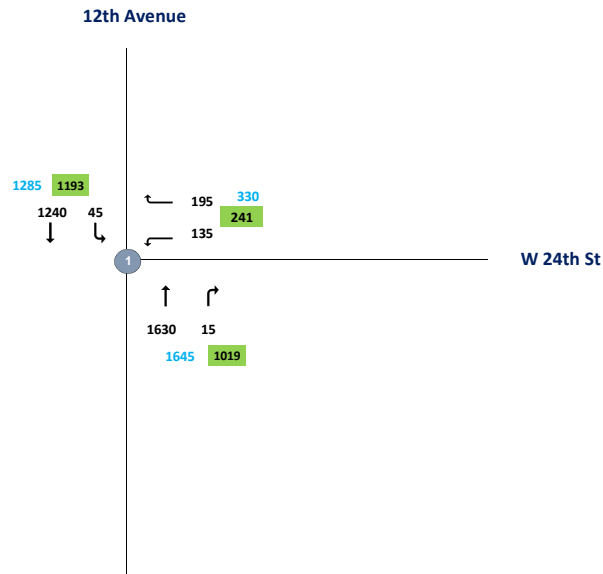

9A

9:00 PM

Intersection	Node	Approach	Total Vehicles					Total
			Inbound/Outbound					
			LN Peak Hour					
			L2	L	T	R	R2	
12th Ave & 24th Street 2019 (TMC-065)	1							
24th Street	1	EB	0	0	0	0	0	
24th Street	1	WB	0	135	0	195	0	
12th Ave	1	NB	0	0	1630	15	0	
12th Ave	1	SB	0	45	1240	0	0	3260

CBD Tolling
Dumbo - Traffic Flowmap
AM Existing



- Legend:**
- 1 - Intersection (2019 Collected Data)
 - 7 - Intersection (Uncollected Data)
 - 100 - ATR Volume
 - 100 - Approach Volume

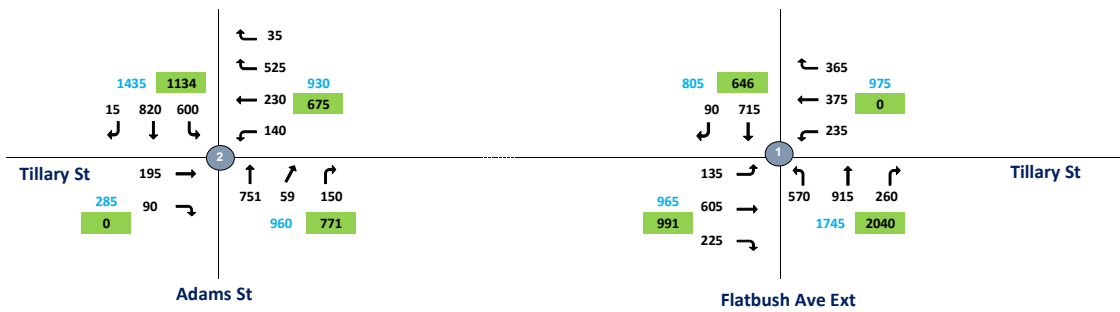

CBD Tolling
Dumbo #2 - Traffic Flowmap
AM Existing



- Legend:**
- 1 - Intersection (2019 Collected Data)
 - 7 - Intersection (Uncollected Data)
 - 100 - ATR Volume
 - 100 - Approach Volume

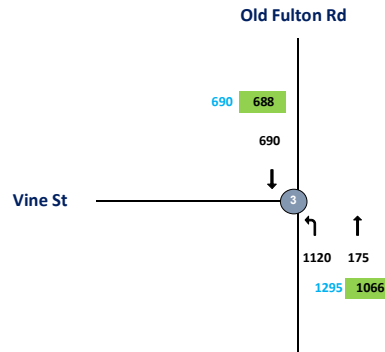

DUMBO

8:00:00 AM

Intersection	Node	Approach	Total Vehicles					
			Inbound/Outbound					
			AM Peak Hour					
			L2	L	T	R	R2	Total
Tillary St & Flatbush Ave ext 2019 (TMC-007)	1							
Tillary St	1	EB	0	135	605	225	0	
Tillary St	1	WB	0	235	375	365	0	
Flatbush Ave ext	1	NB	0	570	915	260	0	
Flatbush Ave ext	1	SB	0	0	715	90	0	4490
Tillary St & Adams St 2019 (TMC-008)	2							
Tillary St	2	EB	0	0	195	90	0	
Tillary St	2	WB	0	140	230	525	35	
Adams St	2	NB	0	0	751	59	150	
Adams St	2	SB	0	600	820	15	0	3610
Vine St & Old Fulton Rd 2019 (TMC-009)	3							
Vine St	3	EB	0	0	0	0	0	
Vine St	3	WB	0	0	0	0	0	
Old Fulton Rd	3	NB	0	1120	175	0	0	
Old Fulton Rd	3	SB	0	0	690	0	0	1985

CBD Tolling
Dumbo - Traffic Flowmap
MD Existing



- Legend:**
- 1 - Intersection (2019 Collected Data)
 - 7 - Intersection (Uncollected Data)
 - 100 - ATR Volume
 - 100 - Approach Volume

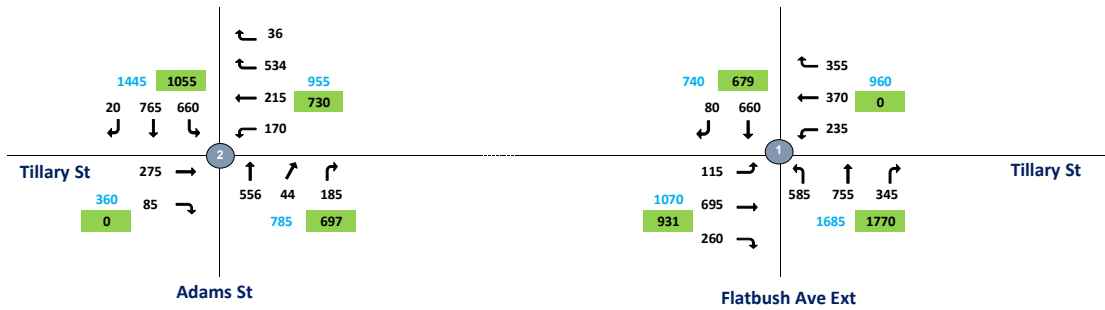

CBD Tolling
Dumbo #2 - Traffic Flowmap
MD Existing



- Legend:**
- 1 - Intersection (2019 Collected Data)
 - 7 - Intersection (Uncollected Data)
 - 100 - ATR Volume
 - 100 - Approach Volume

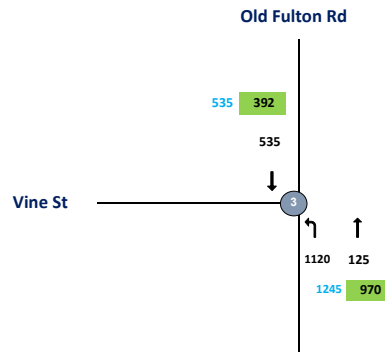

DUMBO

1:00:00 PM

Intersection	Node	Approach	Total Vehicles						
			Inbound/Outbound					Total	
			MD Peak Hour						
			L2	L	T	R	R2		
Tillary St & Flatbush Ave ext 2019 (TMC-007)	1								
Tillary St	1	EB	0	115	695	260	0		
Tillary St	1	WB	0	235	370	355	0		
Flatbush Ave ext	1	NB	0	585	755	345	0		
Flatbush Ave ext	1	SB	0	0	660	80	0	4455	
Tillary St & Adams St 2019 (TMC-008)	2								
Tillary St	2	EB	0	0	275	85	0		
Tillary St	2	WB	0	170	215	534	36		
Adams St	2	NB	0	0	556	44	185		
Adams St	2	SB	0	660	765	20	0	3545	
Vine St & Old Fulton Rd 2019 (TMC-009)	3								
Vine St	3	EB	0	0	0	0	0		
Vine St	3	WB	0	0	0	0	0		
Old Fulton Rd	3	NB	0	1120	125	0	0		
Old Fulton Rd	3	SB	0	0	535	0	0	1780	

CBD Tolling
Dumbo - Traffic Flowmap
PM Existing



- Legend:**
- 1 - Intersection (2019 Collected Data)
 - 7 - Intersection (Uncollected Data)
 - 100 - ATR Volume
 - 100 - Approach Volume

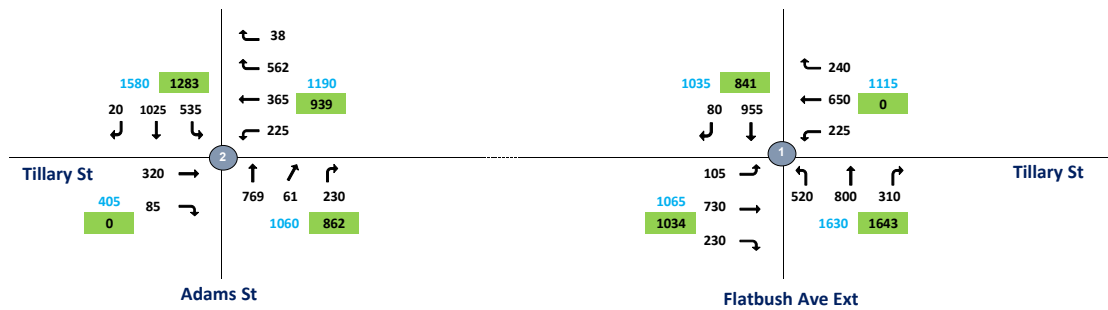

CBD Tolling
Dumbo #2 - Traffic Flowmap
PM Existing



- Legend:**
- 1 - Intersection (2019 Collected Data)
 - 7 - Intersection (Uncollected Data)
 - 100 - ATR Volume
 - 100 - Approach Volume

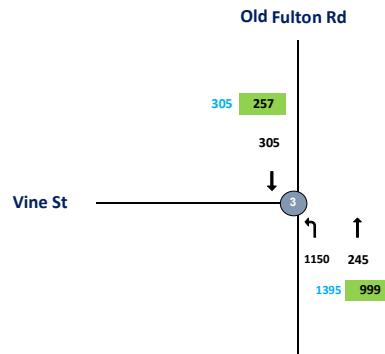

DUMBO

5:00:00 PM

Intersection	Node	Approach	Total Vehicles					
			Inbound/Outbound					Total
			PM Peak Hour					
L2	L	T	R	R2				
Tillary St & Flatbush Ave ext 2019 (TMC-007)	1							
Tillary St	1	EB	0	105	730	230	0	
Tillary St	1	WB	0	225	650	240	0	
Flatbush Ave ext	1	NB	0	520	800	310	0	
Flatbush Ave ext	1	SB	0	0	955	80	0	
							4845	
Tillary St & Adams St 2019 (TMC-008)	2							
Tillary St	2	EB	0	0	320	85	0	
Tillary St	2	WB	0	225	365	562	38	
Adams St	2	NB	0	0	769	61	230	
Adams St	2	SB	0	535	1025	20	0	
							4235	
Vine St & Old Fulton Rd 2019 (TMC-009)	3							
Vine St	3	EB	0	0	0	0	0	
Vine St	3	WB	0	0	0	0	0	
Old Fulton Rd	3	NB	0	1150	245	0	0	
Old Fulton Rd	3	SB	0	0	305	0	0	
							1700	

CBD Tolling
Dumbo - Traffic Flowmap
LN Existing



- Legend:**
- 1 - Intersection (2019 Collected Data)
 - 7 - Intersection (Uncollected Data)
 - 100 - ATR Volume
 - 100 - Approach Volume

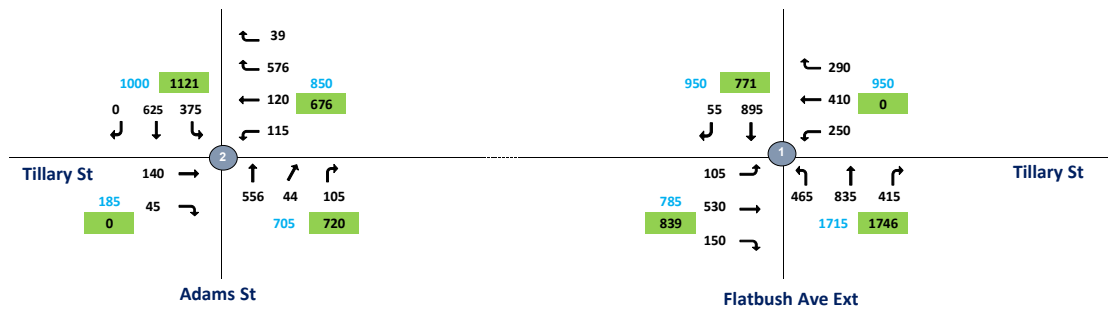

CBD Tolling
Dumbo #2 - Traffic Flowmap
LN Existing



- Legend:**
- 1 - Intersection (2019 Collected Data)
 - 7 - Intersection (Uncollected Data)
 - 100 - ATR Volume
 - 100 - Approach Volume

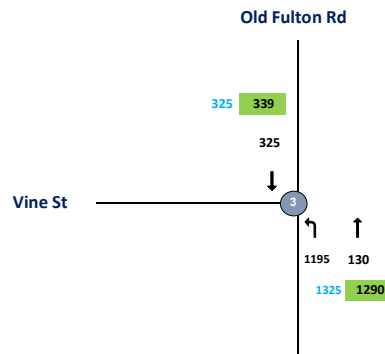

DUMBO

9:00:00 PM

Intersection	Node	Approach	Total Vehicles						
			Inbound/Outbound					Total	
			LN Peak Hour						
			L2	L	T	R	R2		
Tillary St & Flatbush Ave ext 2019 (TMC-007)	1								
Tillary St	1	EB	0	105	530	150	0		
Tillary St	1	WB	0	250	410	290	0		
Flatbush Ave ext	1	NB	0	465	835	415	0		
Flatbush Ave ext	1	SB	0	0	895	55	0		4400
Tillary St & Adams St 2019 (TMC-008)	2								
Tillary St	2	EB	0	0	140	45	0		
Tillary St	2	WB	0	115	120	576	39		
Adams St	2	NB	0	0	556	44	105		
Adams St	2	SB	0	375	625	0	0		2740
Vine St & Old Fulton Rd 2019 (TMC-009)	3								
Vine St	3	EB	0	0	0	0	0		
Vine St	3	WB	0	0	0	0	0		
Old Fulton Rd	3	NB	0	1195	130	0	0		
Old Fulton Rd	3	SB	0	0	325	0	0		1650

CBD Tolling
LIC - Traffic Flowmap #1
AM Existing



- Legend:**
- ① - Intersection (2019 Collected Data)
 - ⑦ - Intersection (Uncollected Data)
 - 100 - ATR Volume
 - 100 - Approach Volume

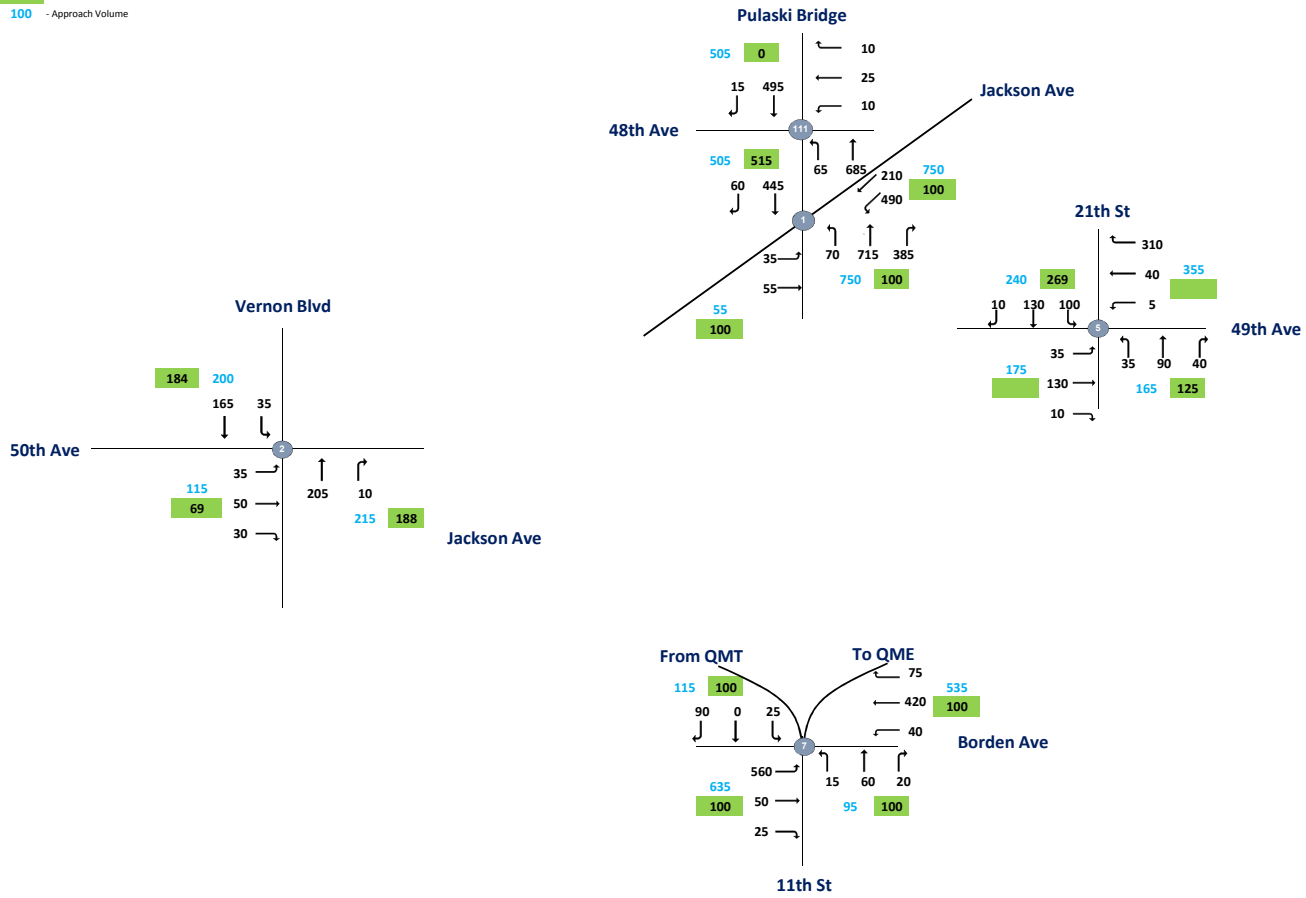

CBD Tolling
LIC - Traffic Flowmap #2
AM Existing



- Legend:**
- 1 - Intersection (2019 Collected Data)
 - 7 - Intersection (Uncollected Data)
 - 100 - ATR Volume
 - 100 - Approach Volume

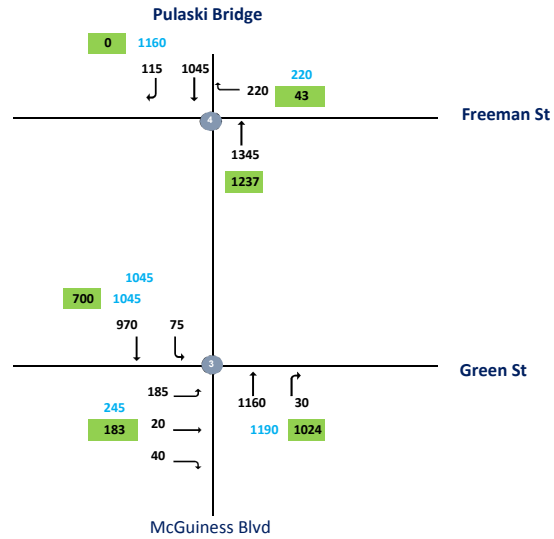

CBD Tolling
LIC - Traffic Flowmap #3
AM Existing



- Legend:**
- 1 - Intersection (2019 Collected Data)
 - 7 - Intersection (Uncollected Data)
 - 100 - ATR Volume
 - 100 - Approach Volume

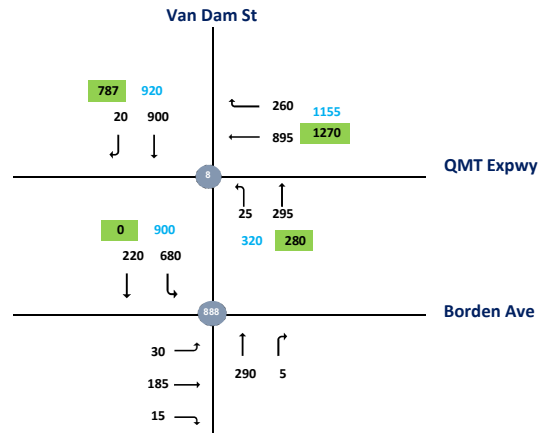

CBD Tolling
LIC - Traffic Flowmap #4
AM Existing



- Legend:**
- 1 - Intersection (2019 Collected Data)
 - 7 - Intersection (Uncollected Data)
 - 100 - ATR Volume
 - 100 - Approach Volume

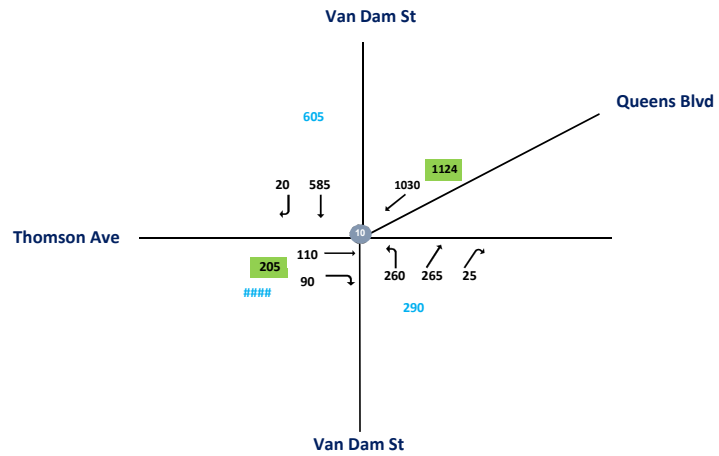
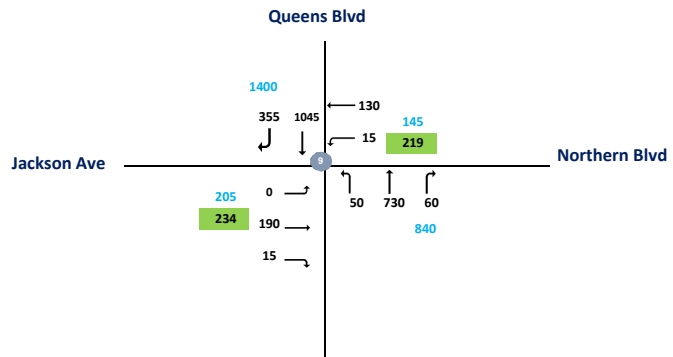

CBD Tolling
LIC - Traffic Flowmap #5
AM Existing



- Legend:**
- 1 - Intersection (2019 Collected Data)
 - 7 - Intersection (Uncollected Data)
 - 100 - ATR Volume
 - 100 - Approach Volume

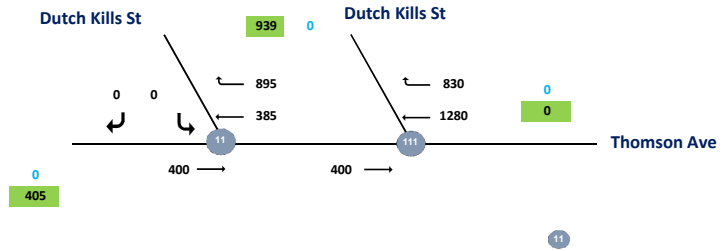

CBD Tolling
LIC - Traffic Flowmap #6
AM Existing



- Legend:**
- 1 - Intersection (2019 Collected Data)
 - 7 - Intersection (Uncollected Data)
 - 100 - ATR Volume
 - 100 - Approach Volume

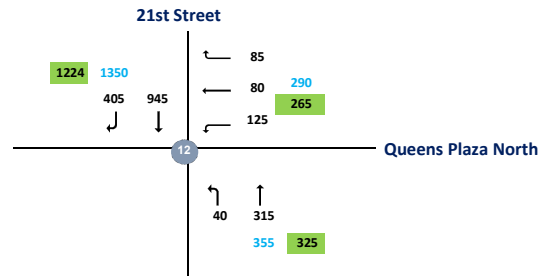

LIC

7:00:00 AM

Intersection	Node	Approach	Total Vehicles					
			Inbound/Outbound					Total
			AM Peak Hour					
L2	L	T	R	R2				
11th St / Pulaski Bridge & Jackson Ave 2017 --> 2019 (LIC_1_TMC-6A)	1							
Pulaski Bridge / 11th St	1	EB	0	35	55	0	0	
Pulaski Bridge / 11th St	1	WB	0	490	210	0	0	
Jackson Ave	1	NB	0	70	715	385	0	
Jackson Ave	1	SB	0	0	445	60	0	2465
11th St / 48th St 2017 --> 2019 (LIC_1_TMC-6A)	111							
11th St	111	EB	0	0	0	0	0	
11th St	111	WB	0	10	25	10	0	
48th St	111	NB	0	65	685	0	0	
48th St	111	SB	0	0	495	15	0	1305
Vernon Blvd & 50th Ave 2019 (TMC-001)	2							
50th Ave	2	EB	0	35	50	30	0	
50th Ave	2	WB	0	0	0	0	0	
Vernon Blvd	2	NB	0	0	205	10	0	
Vernon Blvd	2	SB	0	35	165	0	0	530
Pulaski Bridge & Green St 2019 (TMC-002)	3							
Green St	3	EB	0	185	20	40	0	
Green St	3	WB	0	0	0	0	0	
Pulaski Bridge	3	NB	0	0	1160	30	0	
Pulaski Btridge	3	SB	0	75	970	0	0	2480
Pulaski Bridge & Freeman St 2019 (TMC-003)	4							
Freeman St	4	EB	0	0	0	0	0	
Freeman St	4	WB	0	0	0	220	0	
Pulaski Bridge	4	NB	0	0	1345	0	0	
Pulaski Btridge	4	SB	0	0	1045	115	0	2725
49th Ave & 21st St 2017 --> 2019 (LIC_5_TMC-6C)	5							
49th Ave	5	EB	0	35	130	10	0	
49th Ave	5	WB	0	5	40	310	0	
21th Ave	5	NB	0	35	90	40	0	
21th Ave	5	SB	0	100	130	10	0	935
Borden Ave & 11th Street 2018 -- 2019 (LIC_7_TMC-6D)	7							
Borden Ave	7	EB	0	560	50	25	0	
Borden Ave	7	WB	0	40	420	75	0	
11th St	7	NB	0	15	60	20	0	
11th St	7	SB	0	25	0	90	0	1380

Van Dam St & QMT Expwy (North) 2019 (TMC-004A)	8								
QMT Expwy	8	EB	0	0	0	0	0		
QMT Expwy	8	WB	0	0	895	260	0		
Van Dam St	8	NB	0	25	295	0	0		
Van Dam St	8	SB	0	0	900	20	0		2395
Van Dam St & QMT Expwy (South) 2019 (TMC-004B)	888								
QMT Expwy	888	EB	0	30	185	15	0		
QMT Expwy	888	WB	0	0	0	0	0		
Van Dam St	888	NB	0	0	290	5	0		
Van Dam St	888	SB	0	680	220	0	0		1425
Queens Blvd & Jackson Ave (Mainline) 2018 --> 2019 (LIC_9A_TMC-6E)	9								
Queens Blvd	9	EB	0	0	1045	355	0		
Queens Blvd	9	WB	0	50	730	60	0		
Jackson Ave	9	NB	0	0	190	15	0		
Jackson Ave	9	SB	0	15	130	0	0		2590
Queens Blvd & Jackson Ave (Service Rd) 2018 --> 2019 (LIC_9A_TMC-6F)	9A								
Queens Blvd	9A	EB	0	0	35	355	0		
Queens Blvd	9A	WB	0	0	0	0	0		
Jackson Ave	9A	NB	0	0	0	0	0		
Jackson Ave	9A	SB	0	0	0	0	0		390
Thompson Ave & Queens Blvd 2018 --> 2019 (LIC_10_TMC-6G)	10								
Queens Blvd	10	EB	0	0	0	110	90		
Queens Blvd	10	WB	0	0	1030	0	0		
Thompson Ave	10	NB	0	260	265	0	25		
Thompson Ave	10	SB	0	0	585	20	0		2385
Dutch Kills St & Thomson Ave (#1) 2019 (TMC-005)	11								
Thomson Ave	11	EB	0	0	400	0	0		
Thomson Ave	11	WB	0	0	385	895	0		
Dutch Kills St	11	NB	0	0	0	0	0		
Dutch Kills St	11	SB	0	0	0	0	0		1680
Dutch Kills St & Thomson Ave (#2) 2019 (TMC-005)	1111								
Thomson Ave	1111	EB	0	0	400	0	0		
Thomson Ave	1111	WB	0	0	1280	830	0		
Dutch Kills St	1111	NB	0	0	0	0	0		
Dutch Kills St	1111	SB	0	0	0	0	0		2510
21st Street & Queens Plaza North 2019 (TMC-006)	12								
Queens Plaza North	12	EB	0	0	0	0	0		
Queens Plaza North	12	WB	0	125	80	85	0		
21st Street	12	NB	0	40	315	0	0		
21st Street	12	SB	0	0	945	405	0		1995

CBD Tolling
LIC - Traffic Flowmap #1
MD Existing



- Legend:**
- ① - Intersection (2019 Collected Data)
 - ⑦ - Intersection (Uncollected Data)
 - 100 - ATR Volume
 - 100 - Approach Volume

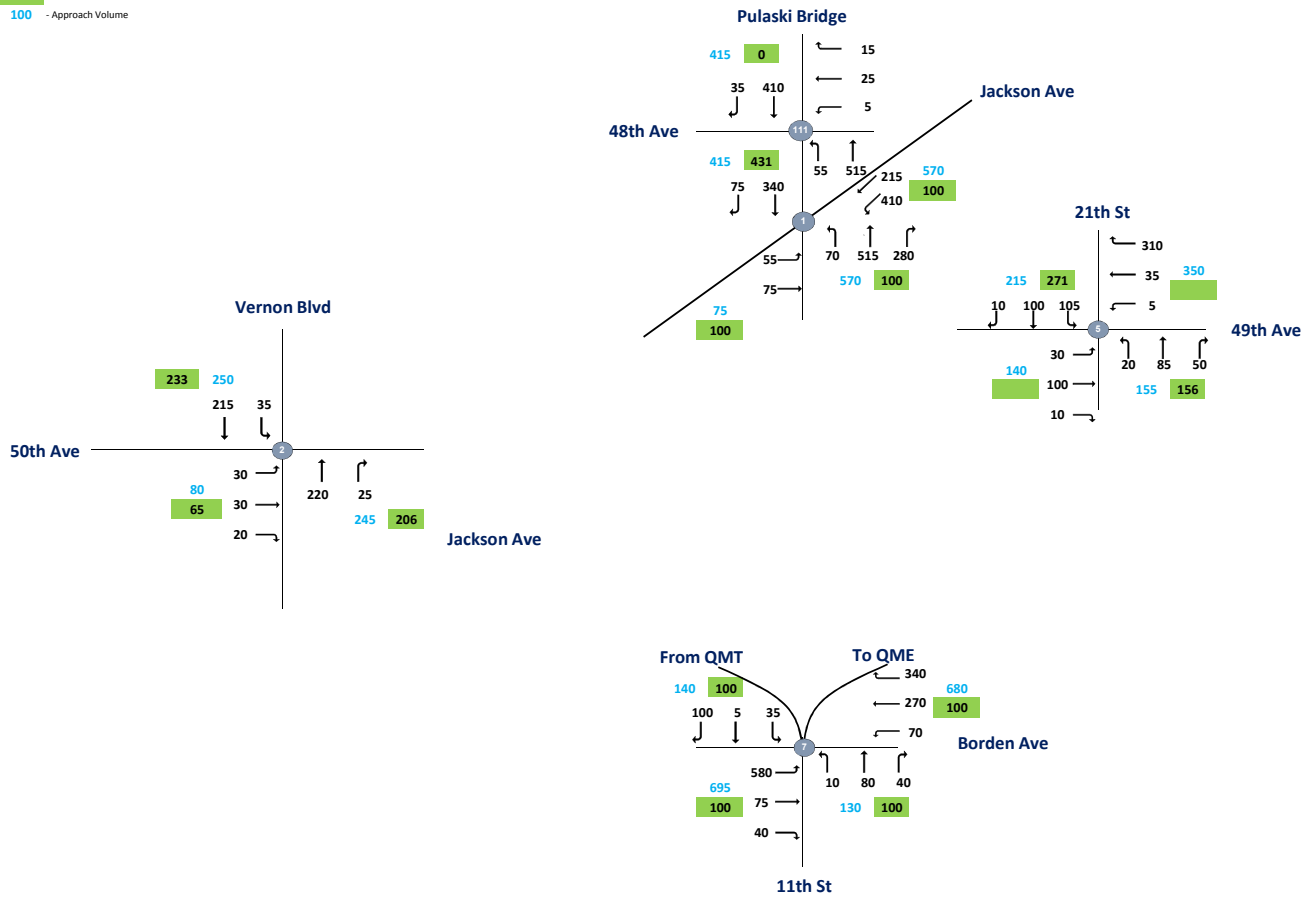

CBD Tolling
LIC - Traffic Flowmap #2
MD Existing



- Legend:**
- 1 - Intersection (2019 Collected Data)
 - 7 - Intersection (Uncollected Data)
 - 100 - ATR Volume
 - 100 - Approach Volume

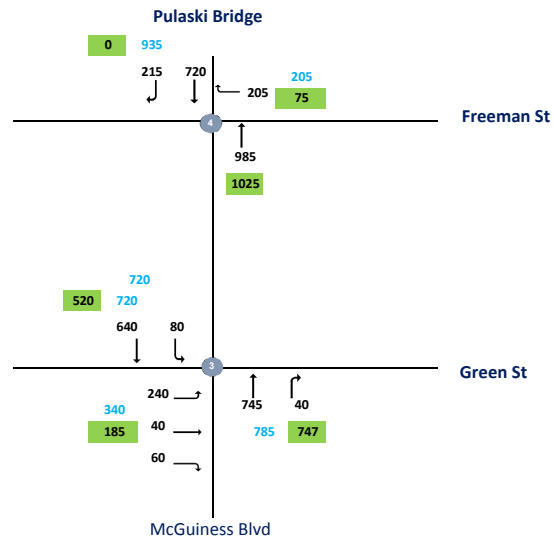

CBD Tolling
LIC - Traffic Flowmap #3
MD Existing



- Legend:**
- ① - Intersection (2019 Collected Data)
 - ⑦ - Intersection (Uncollected Data)
 - 100 - ATR Volume
 - 100 - Approach Volume

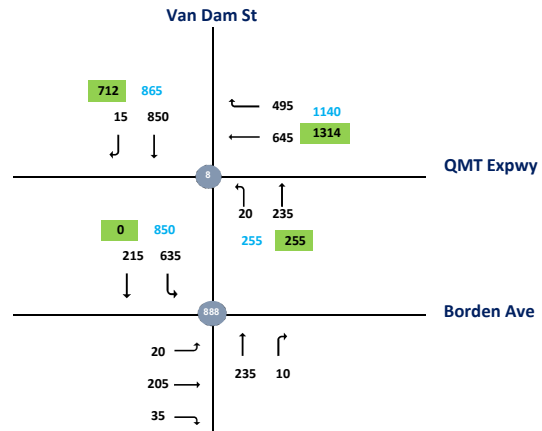

CBD Tolling
LIC - Traffic Flowmap #4
MD Existing



- Legend:**
- 1 - Intersection (2019 Collected Data)
 - 7 - Intersection (Uncollected Data)
 - 100 - ATR Volume
 - 100 - Approach Volume

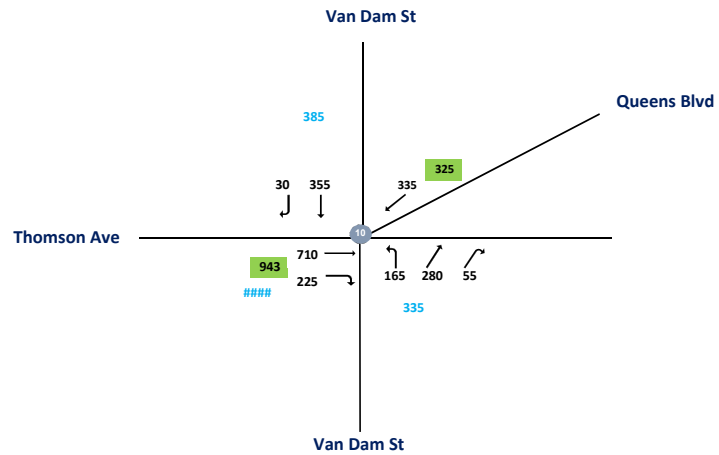
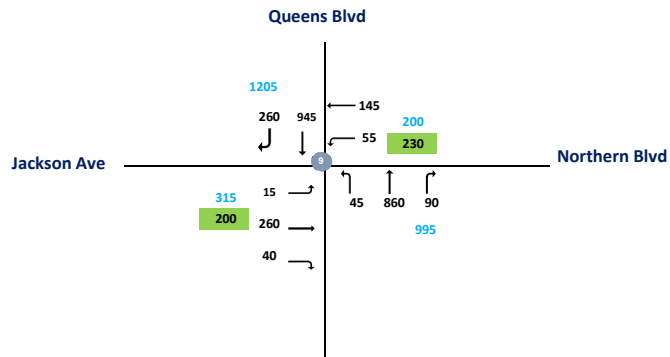

CBD Tolling
LIC - Traffic Flowmap #5
MD Existing



- Legend:**
- 1 - Intersection (2019 Collected Data)
 - 7 - Intersection (Uncollected Data)
 - 100 - ATR Volume
 - 100 - Approach Volume

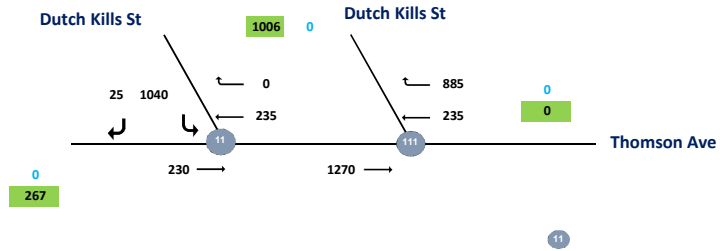

CBD Tolling
LIC - Traffic Flowmap #6
MD Existing



- Legend:**
- 1 - Intersection (2019 Collected Data)
 - 7 - Intersection (Uncollected Data)
 - 100 - ATR Volume
 - 100 - Approach Volume

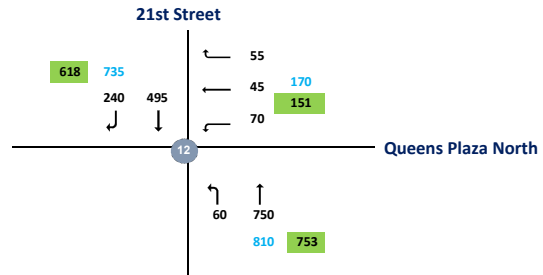

Intersection	Node	Approach	Total Vehicles						
			Inbound/Outbound					Total	
			MD Peak Hour						
			L2	L	T	R	R2		
11th St / Pulaski Bridge & Jackson Ave 2017 --> 2019 (LIC_1_TMC-6A)	1								
Pulaski Bridge / 11th St	1	EB	0	55	75	0	0		
Pulaski Bridge / 11th St	1	WB	0	410	215	0	0		
Jackson Ave	1	NB	0	70	515	280	0		
Jackson Ave	1	SB	0	0	340	75	0	2035	
11th St / 48th St 2017 --> 2019 (LIC_1_TMC-6A)	111								
11th St	111	EB	0	0	0	0	0		
11th St	111	WB	0	5	25	15	0		
48th St	111	NB	0	55	515	0	0		
48th St	111	SB	0	0	410	35	0	1060	
Vernon Blvd & 50th Ave 2019 (TMC-001)	2								
50th Ave	2	EB	0	30	30	20	0		
50th Ave	2	WB	0	0	0	0	0		
Vernon Blvd	2	NB	0	0	220	25	0		
Vernon Blvd	2	SB	0	35	215	0	0	575	
Pulaski Bridge & Green St 2019 (TMC-002)	3								
Green St	3	EB	0	240	40	60	0		
Green St	3	WB	0	0	0	0	0		
Pulaski Bridge	3	NB	0	0	745	40	0		
Pulaski Btridge	3	SB	0	80	640	0	0	1845	
Pulaski Bridge & Freeman St 2019 (TMC-003)	4								
Freeman St	4	EB	0	0	0	0	0		
Freeman St	4	WB	0	0	0	205	0		
Pulaski Bridge	4	NB	0	0	985	0	0		
Pulaski Btridge	4	SB	0	0	720	215	0	2125	
49th Ave & 21st St 2017 --> 2019 (LIC_5_TMC-6C)	5								
49th Ave	5	EB	0	30	100	10	0		
49th Ave	5	WB	0	5	35	310	0		
21th Ave	5	NB	0	20	85	50	0		
21th Ave	5	SB	0	105	100	10	0	860	
Borden Ave & 11th Street 2018 -- 2019 (LIC_7_TMC-6D)	7								
Borden Ave	7	EB	0	580	75	40	0		
Borden Ave	7	WB	0	70	270	340	0		
11th St	7	NB	0	10	80	40	0		
11th St	7	SB	0	35	5	100	0	1645	

Van Dam St & QMT Expwy (North) 2019 (TMC-004A)	8								
QMT Expwy	8	EB	0	0	0	0	0		
QMT Expwy	8	WB	0	0	645	495	0		
Van Dam St	8	NB	0	20	235	0	0		
Van Dam St	8	SB	0	0	850	15	0		2260
Van Dam St & QMT Expwy (South) 2019 (TMC-004B)	888								
QMT Expwy	888	EB	0	20	205	35	0		
QMT Expwy	888	WB	0	0	0	0	0		
Van Dam St	888	NB	0	0	235	10	0		
Van Dam St	888	SB	0	635	215	0	0		1355
Queens Blvd & Jackson Ave (Mainline) 2018 --> 2019 (LIC_9A_TMC-6E)	9								
Queens Blvd	9	EB	0	0	945	260	0		
Queens Blvd	9	WB	0	45	860	90	0		
Jackson Ave	9	NB	0	15	260	40	0		
Jackson Ave	9	SB	0	55	145	0	0		2715
Queens Blvd & Jackson Ave (Service Rd) 2018 --> 2019 (LIC_9A_TMC-6E)	9A								
Queens Blvd	9A	EB	0	0	45	260	0		
Queens Blvd	9A	WB	0	0	0	0	0		
Jackson Ave	9A	NB	0	0	0	0	0		
Jackson Ave	9A	SB	0	0	0	0	0		305
Thompson Ave & Queens Blvd 2018 --> 2019 (LIC_10_TMC-6G)	10								
Queens Blvd	10	EB	0	0	0	710	225		
Queens Blvd	10	WB	0	0	335	0	0		
Thompson Ave	10	NB	0	165	280	0	55		
Thompson Ave	10	SB	0	0	355	30	0		2155
Dutch Kills St & Thomson Ave (#1) 2019 (TMC-005)	11								
Thomson Ave	11	EB	0	0	230	0	0		
Thomson Ave	11	WB	0	0	235	0	0		
Dutch Kills St	11	NB	0	0	0	0	0		
Dutch Kills St	11	SB	0	1040	0	25	0		1530
Dutch Kills St & Thomson Ave (#2) 2019 (TMC-005)	1111								
Thomson Ave	1111	EB	0	0	1270	0	0		
Thomson Ave	1111	WB	0	0	235	885	0		
Dutch Kills St	1111	NB	0	0	0	0	0		
Dutch Kills St	1111	SB	0	0	0	0	0		2390
21st Street & Queens Plaza North 2019 (TMC-006)	12								
Queens Plaza North	12	EB	0	0	0	0	0		
Queens Plaza North	12	WB	0	70	45	55	0		
21st Street	12	NB	0	60	750	0	0		
21st Street	12	SB	0	0	495	240	0		1715

CBD Tolling
LIC - Traffic Flowmap #1
PM Existing



- Legend:**
- ① - Intersection (2019 Collected Data)
 - ⑦ - Intersection (Uncollected Data)
 - 100 - ATR Volume
 - 100 - Approach Volume

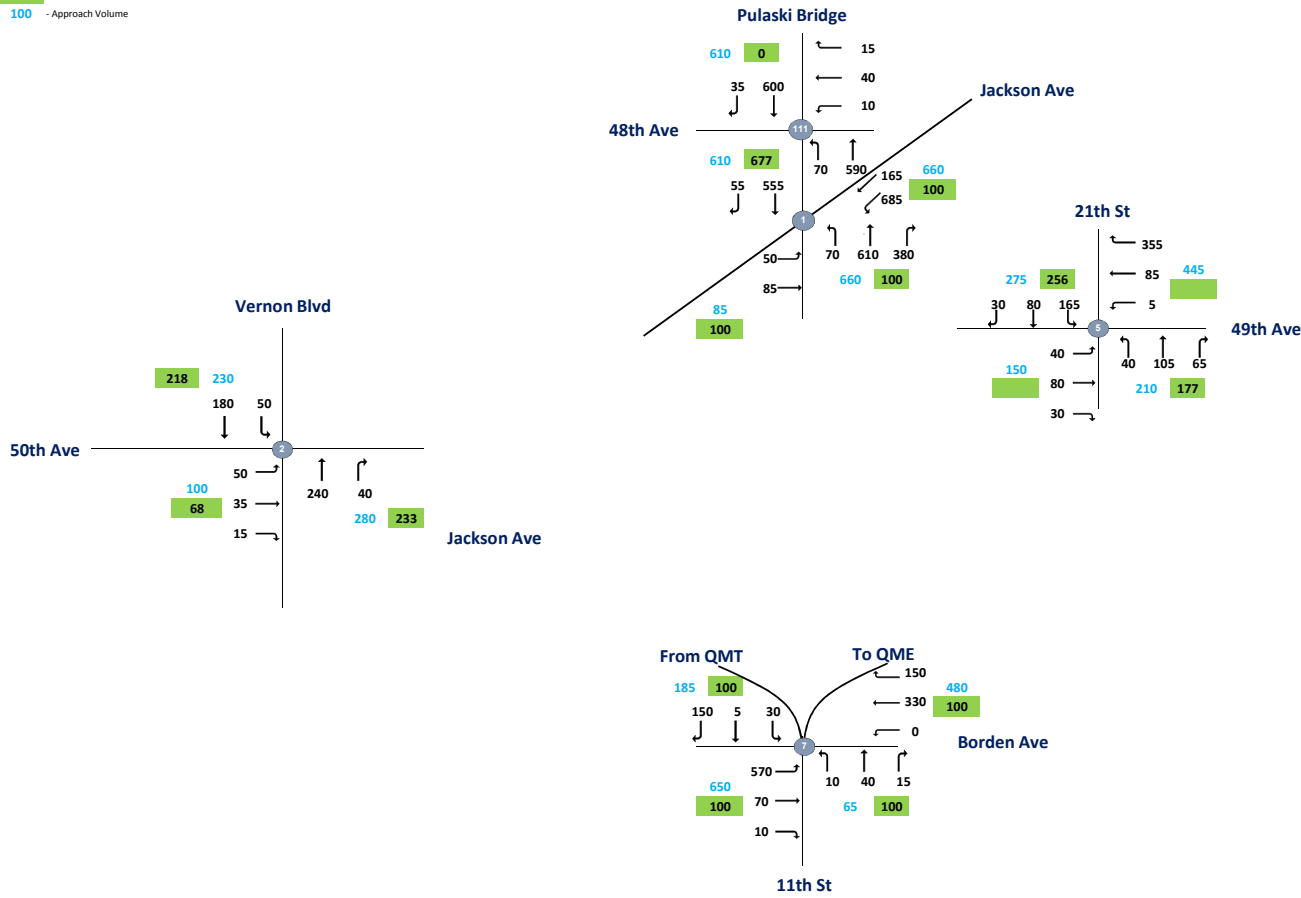

CBD Tolling
LIC - Traffic Flowmap #2
PM Existing



- Legend:**
- 1 - Intersection (2019 Collected Data)
 - 7 - Intersection (Uncollected Data)
 - 100 - ATR Volume
 - 100 - Approach Volume

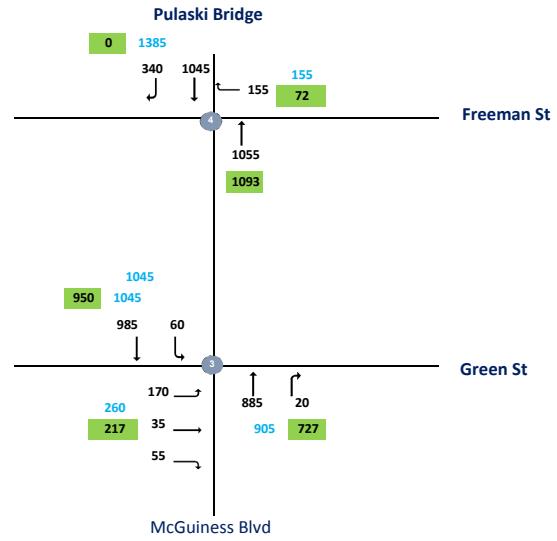

CBD Tolling
LIC - Traffic Flowmap #3
PM Existing



- Legend:**
- 1 - Intersection (2019 Collected Data)
 - 7 - Intersection (Uncollected Data)
 - 100 - ATR Volume
 - 100 - Approach Volume

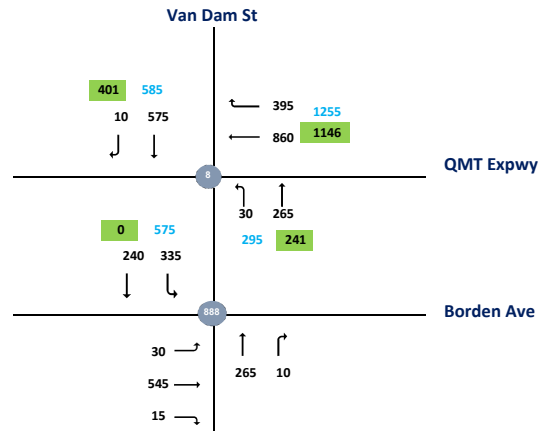

CBD Tolling
LIC - Traffic Flowmap #4
PM Existing



- Legend:**
- ① - Intersection (2019 Collected Data)
 - ⑦ - Intersection (Uncollected Data)
 - 100 - ATR Volume
 - 100 - Approach Volume

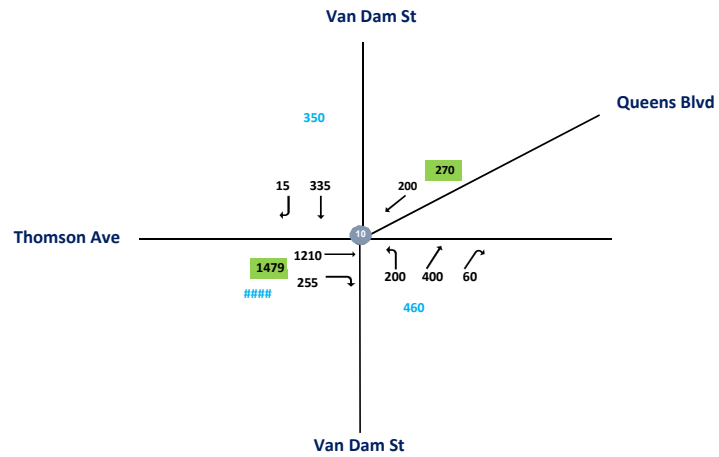
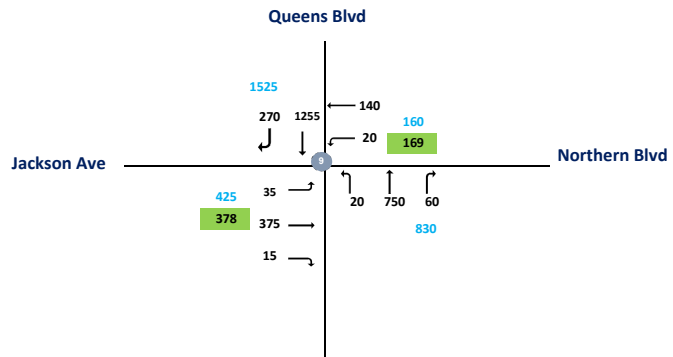

CBD Tolling
LIC - Traffic Flowmap #5
PM Existing



- Legend:**
- ① - Intersection (2019 Collected Data)
 - ⑦ - Intersection (Uncollected Data)
 - 100 - ATR Volume
 - 100 - Approach Volume

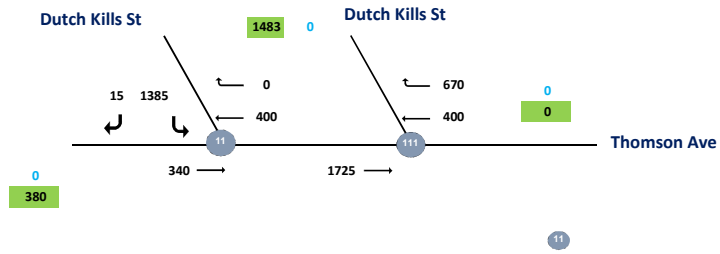

CBD Tolling
LIC - Traffic Flowmap #6
PM Existing



- Legend:**
- 1 - Intersection (2019 Collected Data)
 - 7 - Intersection (Uncollected Data)
 - 100 - ATR Volume
 - 100 - Approach Volume

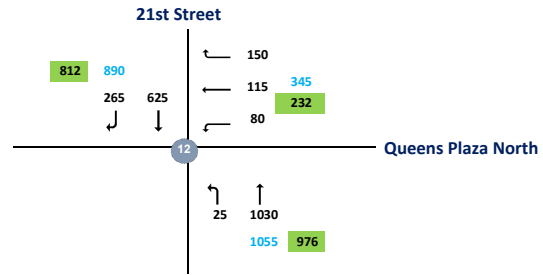

Intersection	Node	Approach	Total Vehicles					
			Inbound/Outbound					Total
			L2	L	T	R	R2	
11th St / Pulaski Bridge & Jackson Ave 2017 --> 2019 (LIC_1_TMC-6A)	1							
Pulaski Bridge / 11th St	1	EB	0	50	85	0	0	
Pulaski Bridge / 11th St	1	WB	0	685	165	0	0	
Jackson Ave	1	NB	0	70	610	380	0	
Jackson Ave	1	SB	0	0	555	55	0	
							2655	
11th St / 48th St 2017 --> 2019 (LIC_1_TMC-6A)	111							
11th St	111	EB	0	0	0	0	0	
11th St	111	WB	0	10	40	15	0	
48th St	111	NB	0	70	590	0	0	
48th St	111	SB	0	0	600	35	0	
							1360	
Vernon Blvd & 50th Ave 2019 (TMC-001)	2							
50th Ave	2	EB	0	50	35	15	0	
50th Ave	2	WB	0	0	0	0	0	
Vernon Blvd	2	NB	0	0	240	40	0	
Vernon Blvd	2	SB	0	50	180	0	0	
							610	
Pulsaki Bridge & Green St 2019 (TMC-002)	3							
Green St	3	EB	0	170	35	55	0	
Green St	3	WB	0	0	0	0	0	
Pulsaki Bridge	3	NB	0	0	885	20	0	
Pulsaki Btridge	3	SB	0	60	985	0	0	
							2210	
Pulsaki Bridge & Freeman St 2019 (TMC-003)	4							
Freeman St	4	EB	0	0	0	0	0	
Freeman St	4	WB	0	0	0	155	0	
Pulsaki Bridge	4	NB	0	0	1055	0	0	
Pulsaki Btridge	4	SB	0	0	1045	340	0	
							2595	
49th Ave & 21st St 2017 --> 2019 (LIC_5_TMC-6C)	5							
49th Ave	5	EB	0	40	80	30	0	
49th Ave	5	WB	0	5	85	355	0	
21th Ave	5	NB	0	40	105	65	0	
21th Ave	5	SB	0	165	80	30	0	
							1080	
Borden Ave & 11th Street 2018 -- 2019 (LIC_7_TMC-6D)	7							
Borden Ave	7	EB	0	570	70	10	0	
Borden Ave	7	WB	0	0	330	150	0	
11th St	7	NB	0	10	40	15	0	
11th St	7	SB	0	30	5	150	0	
							1380	

Van Dam St & QMT Expwy (North) 2019 (TMC-004A)	8								
QMT Expwy	8	EB	0	0	0	0	0		
QMT Expwy	8	WB	0	0	860	395	0		
Van Dam St	8	NB	0	30	265	0	0		
Van Dam St	8	SB	0	0	575	10	0		2135
Van Dam St & QMT Expwy (South) 2019 (TMC-004B)	888								
QMT Expwy	888	EB	0	30	545	15	0		
QMT Expwy	888	WB	0	0	0	0	0		
Van Dam St	888	NB	0	0	265	10	0		
Van Dam St	888	SB	0	335	240	0	0		1440
Queens Blvd & Jackson Ave (Mainline) 2018 --> 2019 (LIC_9A_TMC-6E)	9								
Queens Blvd	9	EB	0	0	1255	270	0		
Queens Blvd	9	WB	0	20	750	60	0		
Jackson Ave	9	NB	0	35	375	15	0		
Jackson Ave	9	SB	0	20	140	0	0		2940
Queens Blvd & Jackson Ave (Service Rd) 2018 --> 2019 (LIC_9A_TMC-6E)	9A								
Queens Blvd	9A	EB	0	0	50	270	0		
Queens Blvd	9A	WB	0	0	0	0	0		
Jackson Ave	9A	NB	0	0	0	0	0		
Jackson Ave	9A	SB	0	0	0	0	0		320
Thompson Ave & Queens Blvd 2018 --> 2019 (LIC_10_TMC-6G)	10								
Queens Blvd	10	EB	0	0	0	1210	255		
Queens Blvd	10	WB	0	0	200	0	0		
Thompson Ave	10	NB	0	200	400	0	60		
Thompson Ave	10	SB	0	0	335	15	0		2675
Dutch Kills St & Thomson Ave (#1) 2019 (TMC-005)	11								
Thomson Ave	11	EB	0	0	340	0	0		
Thomson Ave	11	WB	0	0	400	0	0		
Dutch Kills St	11	NB	0	0	0	0	0		
Dutch Kills St	11	SB	0	1385	0	15	0		2140
Dutch Kills St & Thomson Ave (#2) 2019 (TMC-005)	1111								
Thomson Ave	1111	EB	0	0	1725	0	0		
Thomson Ave	1111	WB	0	0	400	670	0		
Dutch Kills St	1111	NB	0	0	0	0	0		
Dutch Kills St	1111	SB	0	0	0	0	0		2795
21st Street & Queens Plaza North 2019 (TMC-006)	12								
Queens Plaza North	12	EB	0	0	0	0	0		
Queens Plaza North	12	WB	0	80	115	150	0		
21st Street	12	NB	0	25	1030	0	0		
21st Street	12	SB	0	0	625	265	0		2290

CBD Tolling
LM - Traffic Flowmap #1
AM Existing



- Legend:**
- ① - Intersection (2019 Collected Data)
 - ⑦ - Intersection (Uncollected Data)
 - 100 - ATR Volume
 - 100 - Approach Volume

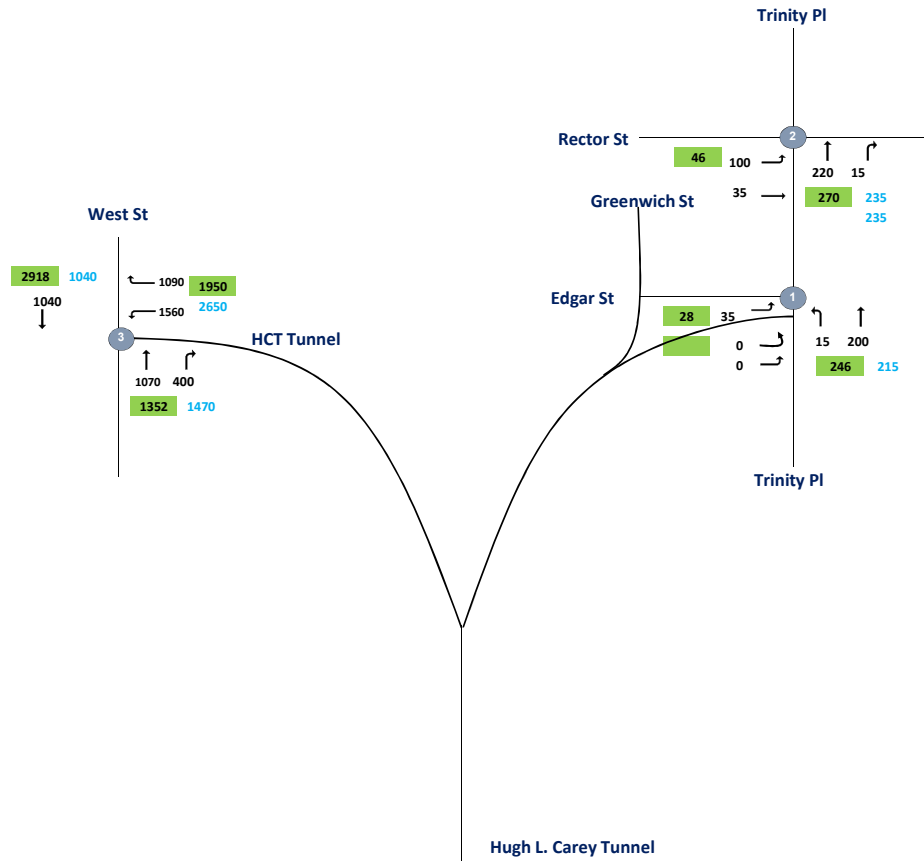

CBD Tolling
LM - Traffic Flowmap #2
AM Existing

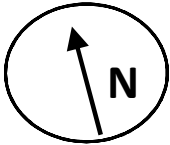

Legend:

- 1 - Intersection (2019 Collected Data)
- 7 - Intersection (Uncollected Data)
- 100 - ATR Volume
- 100 - Approach Volume

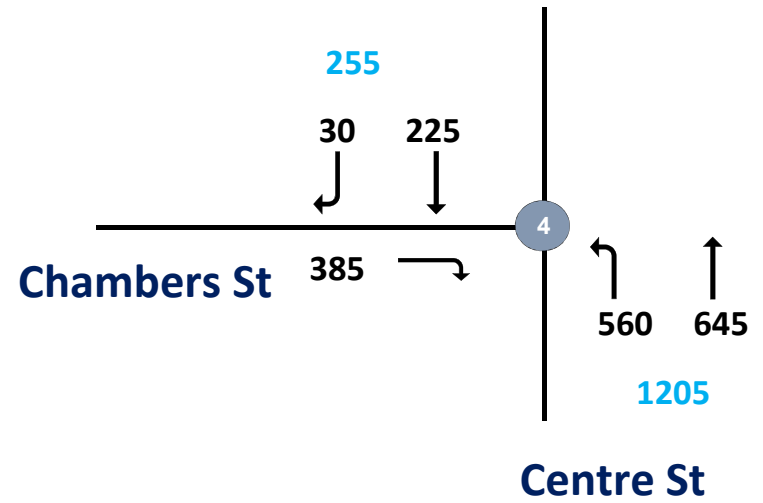

CBD Tolling
LM - Traffic Flowmap #3
AM Existing



- Legend:**
- 1 - Intersection (2019 Collected Data)
 - 7 - Intersection (Uncollected Data)
 - ATR Volume
 - 100 - Approach Volume

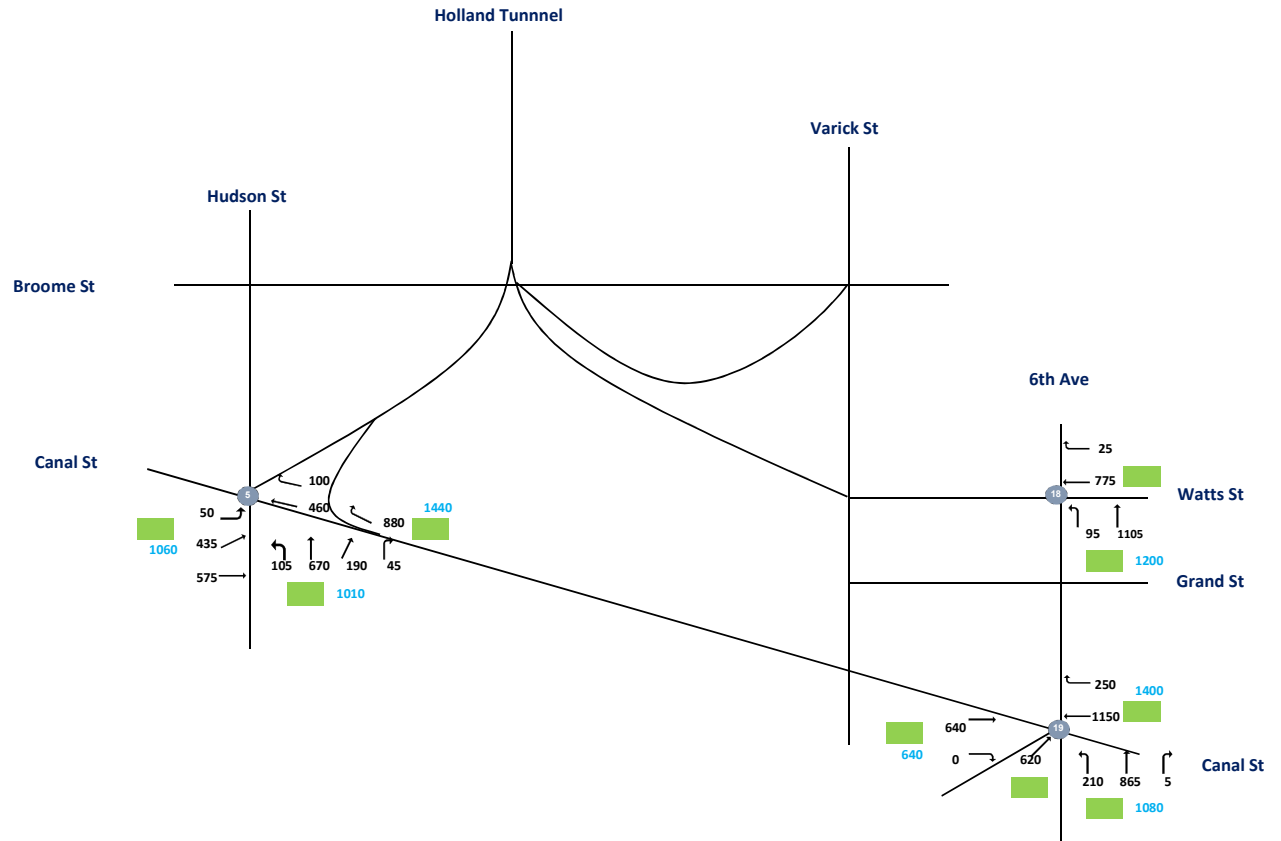

CBD Tolling
LM - Traffic Flowmap #4
AM Existing



- Legend:**
- 1 - Intersection (2019 Collected Data)
 - 7 - Intersection (Uncollected Data)
 - 100 - ATR Volume
 - 100 - Approach Volume

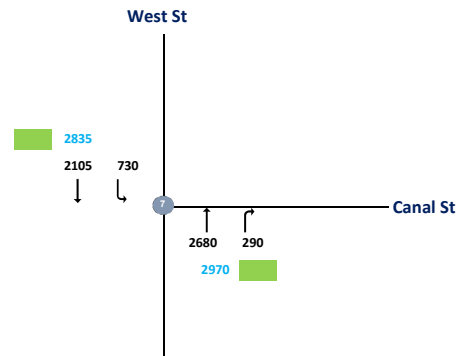

CBD Tolling
LM - Traffic Flowmap #5
AM Existing



- Legend:**
- ① - Intersection (2019 Collected Data)
 - ⑦ - Intersection (Uncollected Data)
 - 100 - ATR Volume
 - 100 - Approach Volume

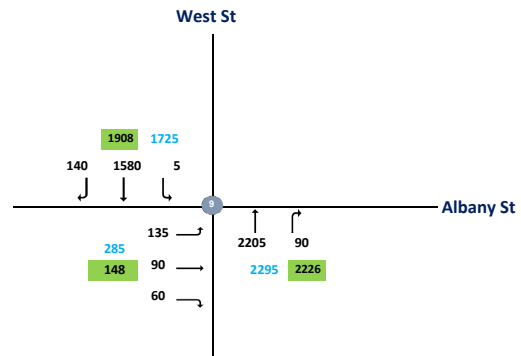

CBD Tolling
LM - Traffic Flowmap #6
AM Existing



- Legend:**
- 1 - Intersection (2019 Collected Data)
 - 7 - Intersection (Uncollected Data)
 - 100 - ATR Volume
 - 100 - Approach Volume
 - ↯ - Illegal movement

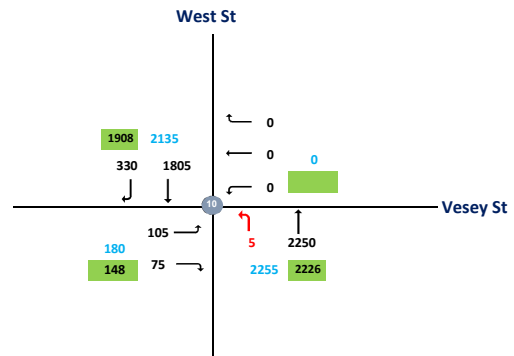

CBD Tolling
LM - Traffic Flowmap #7
AM Existing



- Legend:**
- 1 - Intersection (2019 Collected Data)
 - 7 - Intersection (Uncollected Data)
 - 100 - ATR Volume
 - 100 - Approach Volume

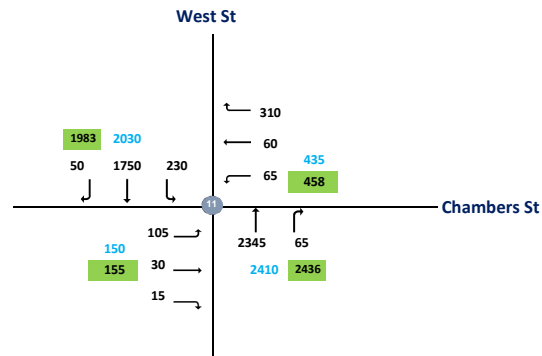

CBD Tolling
LM - Traffic Flowmap #8
AM Existing



- Legend:**
- 1 - Intersection (2019 Collected Data)
 - 7 - Intersection (Uncollected Data)
 - ATR Volume
 - 100 - Approach Volume

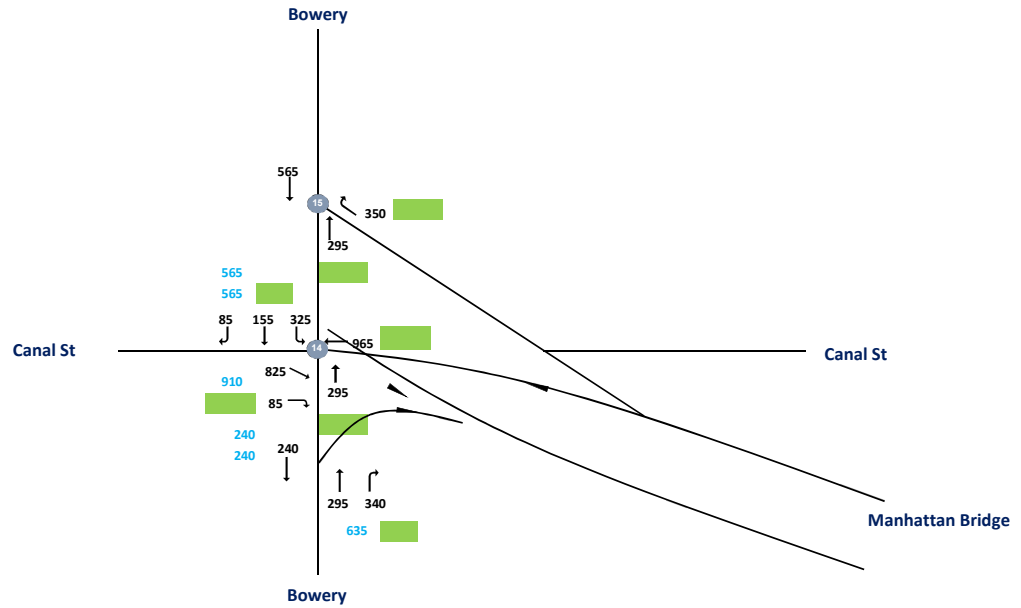

Intersection	Node	Approach	Total Vehicles					
			Inbound/Outbound					Total
			L2	L	T	R	R2	
Edgar St. and Trinity Pl. 2019 (TMC-010)	1							
Edgar St.	1	EB	0	35	0	0	0	
478 Exit Ramp.	1	NE	0	0	0	0	0	
Trinity Pl.	1	NB	0	15	200	0	0	
Trinity Pl.	1	SB	0	0	0	0	0	250
Rector St. and Trinity Pl. 2019 (TMC-011)	2							
Rector St.	2	EB	0	100	35	0	0	
Rector St.	2	WB	0	0	0	0	0	
Trinity Pl.	2	NB	0	0	220	15	0	
Trinity Pl.	2	SB	0	0	0	0	0	370
West St. and HCT Exit. 2019 (TMC-012)	3							
-	3	EB	0	0	0	0	0	
HCT Exit.	3	WB	0	1560	0	0	0	
West St.	3	NB	0	0	1070	0	400	
West St.	3	SB	0	0	1040	0	0	4070
West St. and HCT Exit. 2019 (TMC-012)	333							
W. Thams St.	333	EB	0	0	0	0	0	
HCT Exit.	333	WB	0	0	0	1090	0	
West St.	333	NB	0	0	1070	0	0	
West St.	333	SB	0	0	1040	0	0	3200
Chambers St. and Centre St. 2018	4							
Chambers St.	4	EB	0	0	0	385	0	
-	4	WB	0	0	0	0	0	
Centre St.	4	NB	0	560	645	0	0	
Centre St.	4	SB	0	0	225	30	0	1845
Hudson St. and Canal St. 2018	5							
Canal St.	5	EB	50	435	575	0	0	
Canal St.	5	WB	0	0	460	100	0	
Hudson St.	5	NB	0	105	670	190	45	
Hudson St.	5	SB	0	0	0	0	0	2630

Hudson St. and Canal St.								
2018	555							
Canal St.	555	EB	0	0	620	0	0	
Canal St.	555	WB	0	0	560	880	0	
Hudson St.	555	NB	0	0	0	0	0	
Hudson St.	555	SB	0	0	0	0	0	2060
West St. and Canal St N.								
2018	7							
Canal St N.	7	EB	0	0	0	0	0	
-	7	WB	0	0	0	0	0	
West St.	7	NB	0	0	2680	290	0	
West St.	7	SB	0	730	2105	0	0	5805
West St. and Canal St S.								
2018	777							
-	777	EB	0	0	0	0	0	
Canal St S.	777	WB	0	0	0	0	0	
West St.	777	NB	0	0	2680	0	0	
West St.	777	SB	0	0	2835	0	0	5515
West St. and Albany St.								
2019 (TMC-013)	9							
Albany St.	9	EB	0	135	90	60	0	
-	9	WB	0	0	0	0	0	
West St.	9	NB	0	0	2205	90	0	
West St.	9	SB	0	5	1580	140	0	4305
West St. and Vesey St.								
2019 (TMC-014)	10							
Vesey St.	10	EB	0	105	0	75	0	
Vesey St.	10	WB	0	0	0	0	0	
West St.	10	NB	0	5	2250	0	0	
West St.	10	SB	0	0	1805	330	0	250
West St. and Chambers St.								
2019 (TMC-015)	11							
Chambers St.	11	EB	0	105	30	15	0	
Chambers St.	11	WB	0	65	60	310	0	
West St.	11	NB	0	0	2345	65	0	
West St.	11	SB	0	230	1750	50	0	5025

Bowey and Canal St./Manhattan Bridge Off-Ramp								
2018	14							
Canal St.	14	EB	0	0	825	85	0	
Manhattan Bridge Off-Ramp	14	WB	0	0	965	0	0	
Bowey	14	NB	0	0	295	340	0	
Bowey	14	SB	0	325	155	85	0	3075
Bowey and Manhattan Bridge Off-Ramp								
2018	15							
	15	EB						
Manhattan Bridge Off-Ramp	15	WB				350		
Bowey	15	NB			295			
Bowey	15	SB			565			1210
6th Ave. and Watts St								
2018	18							
Watts St	18	EB	0	0	0	0	0	
Watts St	18	WB	0	0	775	25	0	
6th Ave.	18	NB	0	95	1105	0	0	
6th Ave.	18	SB	0	0	0	0	0	2000
6th Ave. and Canal St.								
2018	19							
Canal St.	19	EB	0	0	640	0	0	
Canal St.	19	WB	0	0	1150	250	0	
6th Ave.	19	NB	0	210	865	5	0	
Laight St.	19	NE	0	0	0	620	0	3740

CBD Tolling
LM - Traffic Flowmap #1
MD Existing



- Legend:**
- ① - Intersection (2019 Collected Data)
 - ⑦ - Intersection (Uncollected Data)
 - 100 - ATR Volume
 - .100 - Approach Volume

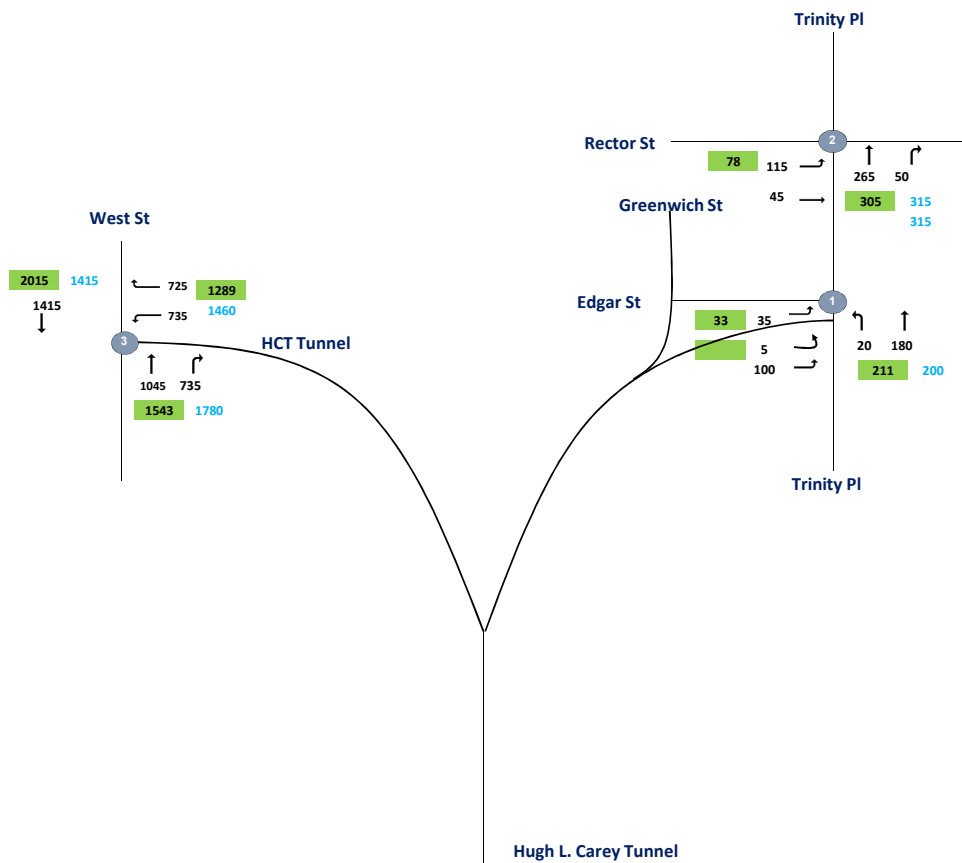

CBD Tolling
LM - Traffic Flowmap #2
MD Existing

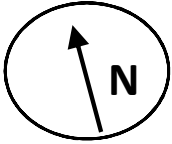

Legend:

1 - Intersection (2019 Collected Data)

7 - Intersection (Uncollected Data)

100 - ATR Volume

100 - Approach Volume

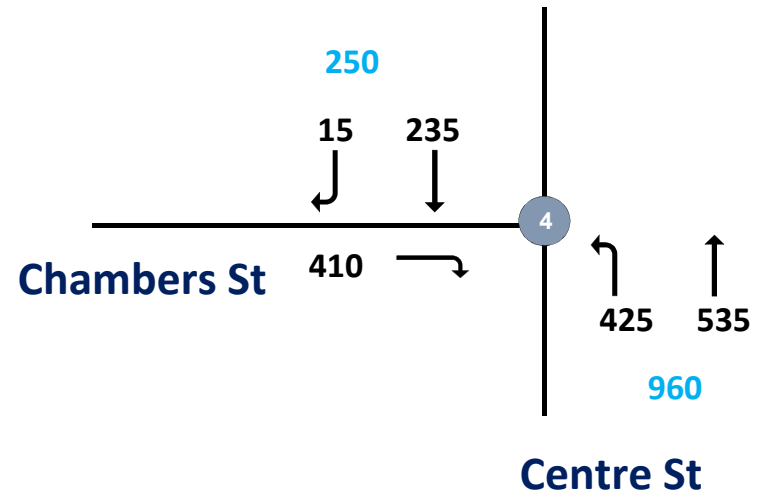

CBD Tolling
LM - Traffic Flowmap #3
MD Existing



- Legend:**
- ① - Intersection (2019 Collected Data)
 - ⑦ - Intersection (Uncollected Data)
 - 100 - ATR Volume
 - 100 - Approach Volume

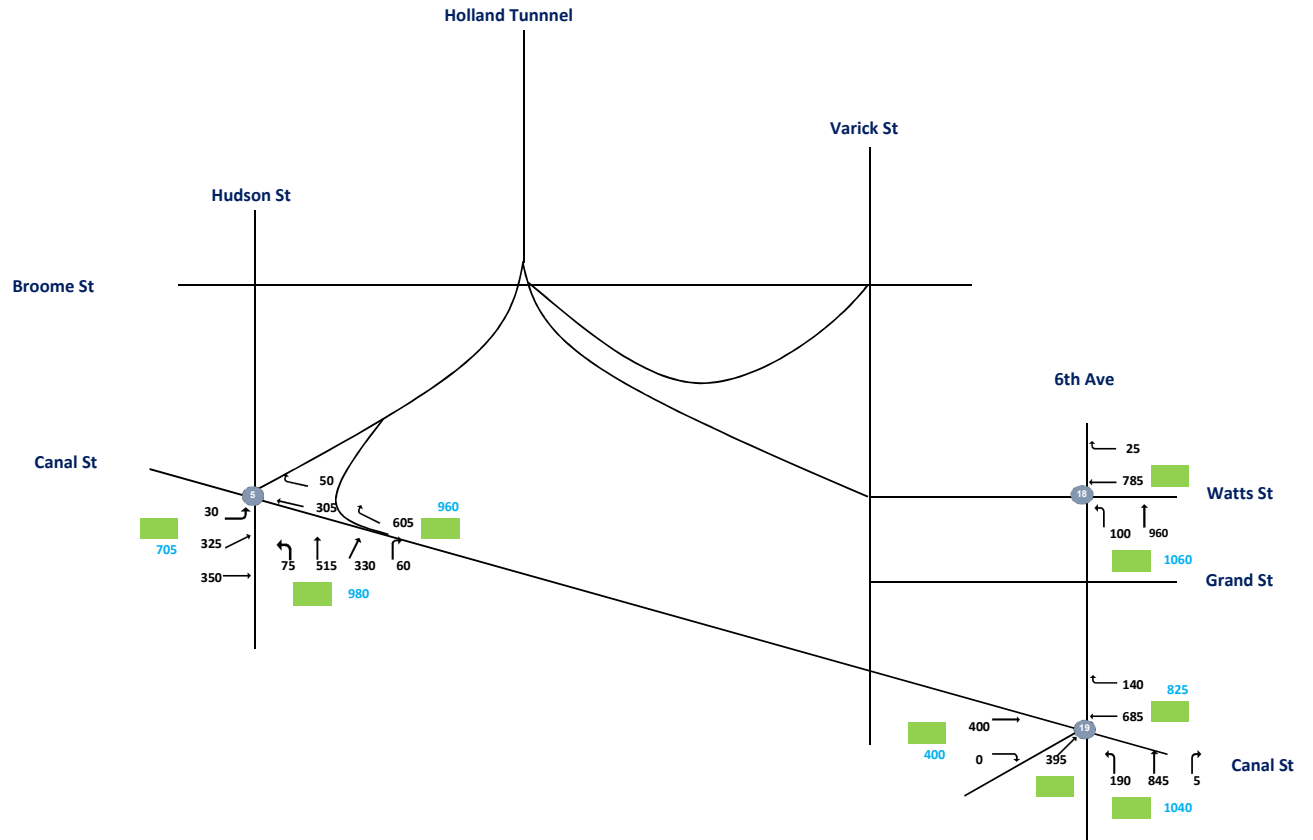

CBD Tolling
LM - Traffic Flowmap #4
MD Existing



- Legend:**
- 1 - Intersection (2019 Collected Data)
 - 7 - Intersection (Uncollected Data)
 - 100 - ATR Volume
 - 100 - Approach Volume



CBD Tolling
LM - Traffic Flowmap #5
MD Existing



- Legend:**
- 1 - Intersection (2019 Collected Data)
 - 7 - Intersection (Uncollected Data)
 - 100 - ATR Volume
 - 100 - Approach Volume

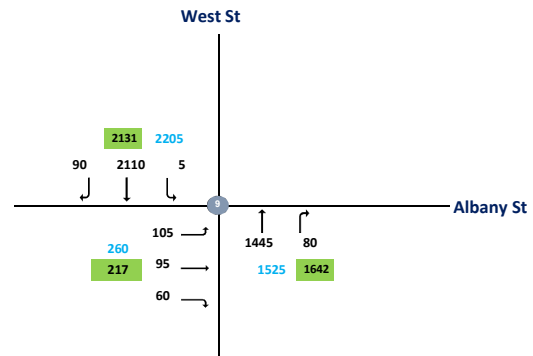

CBD Tolling
LM - Traffic Flowmap #6
MD Existing



- Legend:**
- 1 - Intersection (2019 Collected Data)
 - 7 - Intersection (Uncollected Data)
 - 100 - ATR Volume
 - 100 - Approach Volume
 - ↪ - Illegal movement

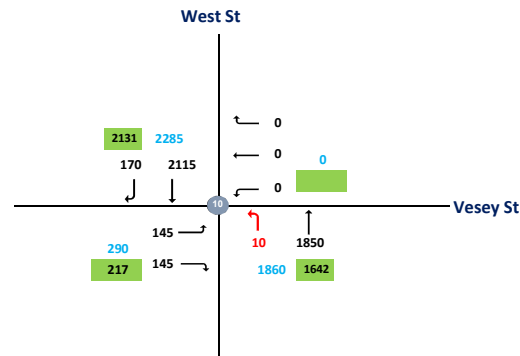

CBD Tolling
LM - Traffic Flowmap #7
MD Existing



- Legend:**
- 1 - Intersection (2019 Collected Data)
 - 7 - Intersection (Uncollected Data)
 - 100 - ATR Volume
 - 100 - Approach Volume

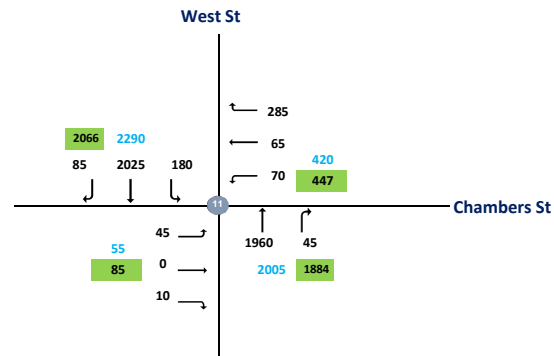

CBD Tolling
LM - Traffic Flowmap #8
MD Existing



- Legend:**
- 1 - Intersection (2019 Collected Data)
 - 7 - Intersection (Uncollected Data)
 - 100 - ATR Volume
 - 100 - Approach Volume

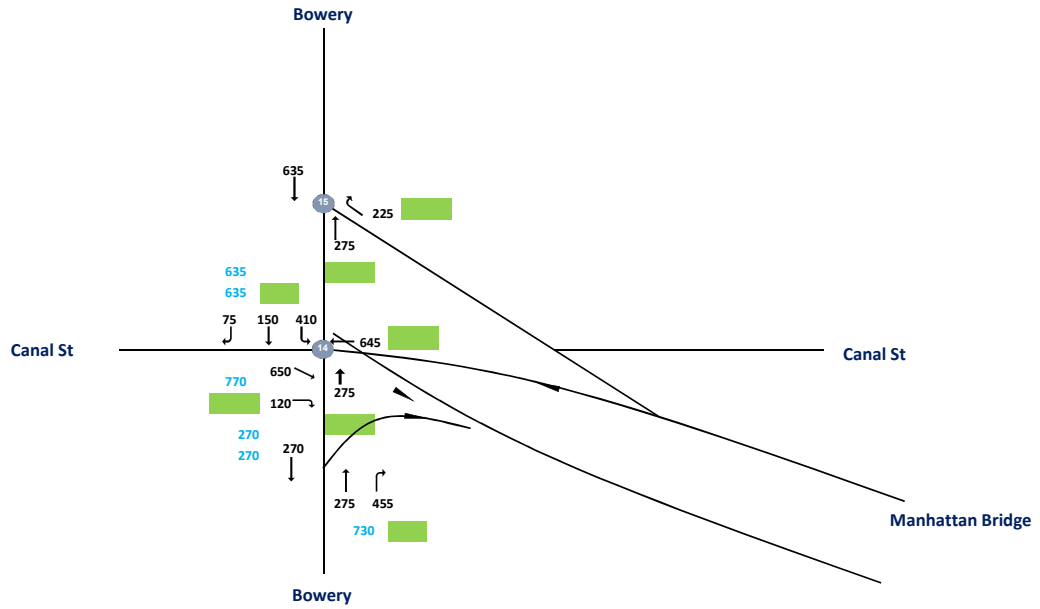

Intersection	Node	Approach	Total Vehicles					
			Inbound/Outbound					Total
			MD Peak Hour					
L2	L	T	R	R2				
Edgar St. and Trinity Pl. 2019 (TMC-010)	1							
Edgar St.	1	EB	0	35	0	0	0	
478 Exit Ramp.	1	NE	5	100	0	0	0	
Trinity Pl.	1	NB	0	20	180	0	0	
Trinity Pl.	1	SB	0	0	0	0	0	
							340	
Rector St. and Trinity Pl. 2019 (TMC-011)	2							
Rector St.	2	EB	0	115	45	0	0	
Rector St.	2	WB	0	0	0	0	0	
Trinity Pl.	2	NB	0	0	265	50	0	
Trinity Pl.	2	SB	0	0	0	0	0	
							475	
West St. and HCT Exit. 2019 (TMC-012)	3							
-	3	EB	0	0	0	0	0	
HCT Exit.	3	WB	0	735	0	0	0	
West St.	3	NB	0	0	1045	0	735	
West St.	3	SB	0	0	1415	0	0	
							3930	
West St. and HCT Exit. 2019 (TMC-012)	333							
W. Thams St.	333	EB	0	0	0	0	0	
HCT Exit.	333	WB	0	0	0	725	0	
West St.	333	NB	0	0	1045	0	0	
West St.	333	SB	0	0	1415	0	0	
							3185	
Chambers St. and Centre St. 2018	4							
Chambers St.	4	EB	0	0	0	410	0	
-	4	WB	0	0	0	0	0	
Centre St.	4	NB	0	425	535	0	0	
Centre St.	4	SB	0	0	235	15	0	
							1620	
Hudson St. and Canal St. 2018	5							
Canal St.	5	EB	30	325	350	0	0	
Canal St.	5	WB	0	0	305	50	0	
Hudson St.	5	NB	0	75	515	330	60	
Hudson St.	5	SB	0	0	0	0	0	
							2040	

Hudson St. and Canal St.								
2018	555							
Canal St.	555	EB	0	0	410	0	0	
Canal St.	555	WB	0	0	355	605	0	
Hudson St.	555	NB	0	0	0	0	0	
Hudson St.	555	SB	0	0	0	0	0	1370
West St. and Canal St N.								
2018	7							
Canal St N.	7	EB	0	0	0	0	0	
-	7	WB	0	0	0	0	0	
West St.	7	NB	0	0	2105	165	0	
West St.	7	SB	0	440	1860	0	0	4570
West St. and Canal St S.								
2018	777							
-	777	EB	0	0	0	0	0	
Canal St S.	777	WB	0	0	0	0	0	
West St.	777	NB	0	0	2105	0	0	
West St.	777	SB	0	0	2300	0	0	4405
West St. and Albany St.								
2019 (TMC-013)	9							
Albany St.	9	EB	0	105	95	60	0	
-	9	WB	0	0	0	0	0	
West St.	9	NB	0	0	1445	80	0	
West St.	9	SB	0	5	2110	90	0	3990
West St. and Vesey St.								
2019 (TMC-014)	10							
Vesey St.	10	EB	0	145	0	145	0	
Vesey St.	10	WB	0	0	0	0	0	
West St.	10	NB	0	10	1850	0	0	
West St.	10	SB	0	0	2115	170	0	340
West St. and Chambers St.								
2019 (TMC-015)	11							
Chambers St.	11	EB	0	45	0	10	0	
Chambers St.	11	WB	0	70	65	285	0	
West St.	11	NB	0	0	1960	45	0	
West St.	11	SB	0	180	2025	85	0	4770

Bowey and Canal St./Manhattan Bridge Off-Ramp									
2018	14								
Canal St.	14	EB	0	0	650	120	0		
Manhattan Bridge Off-Ramp	14	WB	0	0	645	0	0		
Bowey	14	NB	0	0	275	455	0		
Bowey	14	SB	0	410	150	75	0		2780
Bowey and Manhattan Bridge Off-Ramp									
2018	15								
	15	EB							
Manhattan Bridge Off-Ramp	15	WB				225			
Bowey	15	NB			275				
Bowey	15	SB			635				1135
6th Ave. and Watts St									
2018	18								
Watts St	18	EB	0	0	0	0	0		
Watts St	18	WB	0	0	785	25	0		
6th Ave.	18	NB	0	100	960	0	0		
6th Ave.	18	SB	0	0	0	0	0		1870
6th Ave. and Canal St.									
2018	19								
Canal St.	19	EB	0	0	400	0	0		
Canal St.	19	WB	0	0	685	140	0		
6th Ave.	19	NB	0	190	845	5	0		
Laight St.	19	NE	0	0	0	395	0		2660

CBD Tolling
LM - Traffic Flowmap #1
PM Existing



- Legend:**
- ① - Intersection (2019 Collected Data)
 - ⑦ - Intersection (Uncollected Data)
 - 100 - ATR Volume
 - 100 - Approach Volume

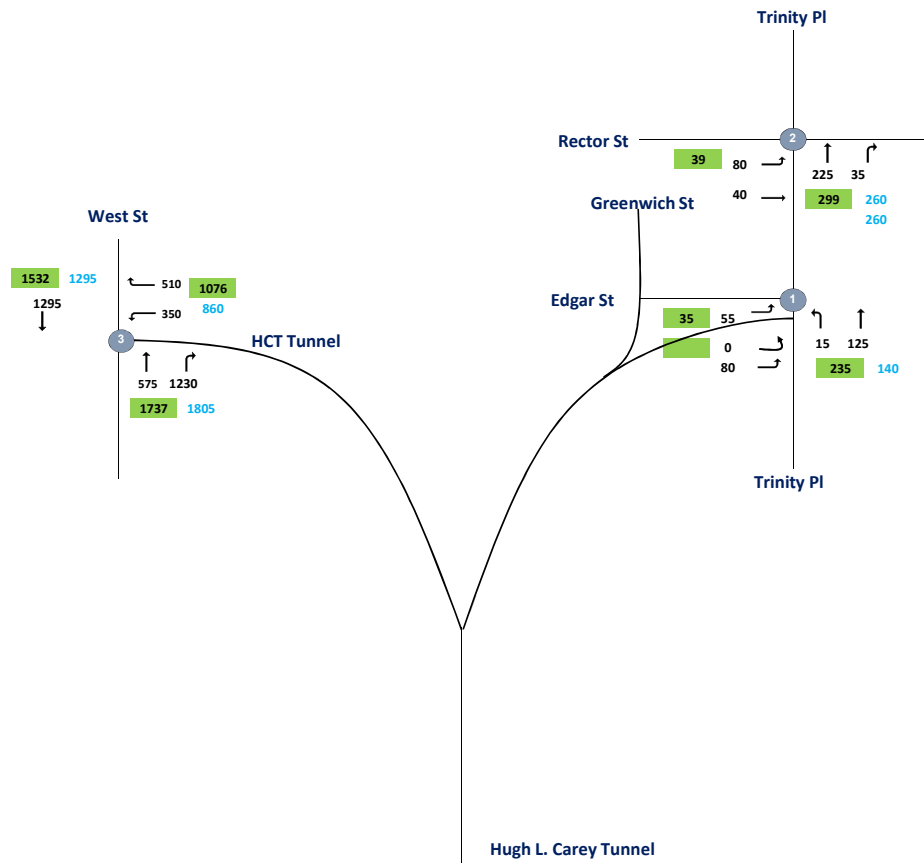

CBD Tolling
LM - Traffic Flowmap #2
PM Existing

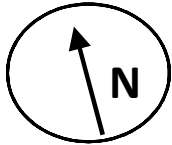

Legend:

1 - Intersection (2019 Collected Data)

7 - Intersection (Uncollected Data)

100 - ATR Volume

100 - Approach Volume

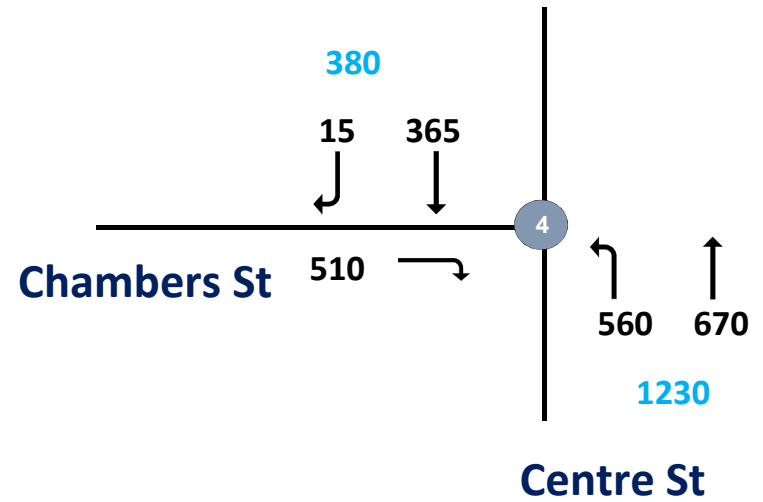

CBD Tolling
LM - Traffic Flowmap #3
PM Existing



- Legend:**
- 1 - Intersection (2019 Collected Data)
 - 7 - Intersection (Uncollected Data)
 - ATR Volume
 - 100 - Approach Volume

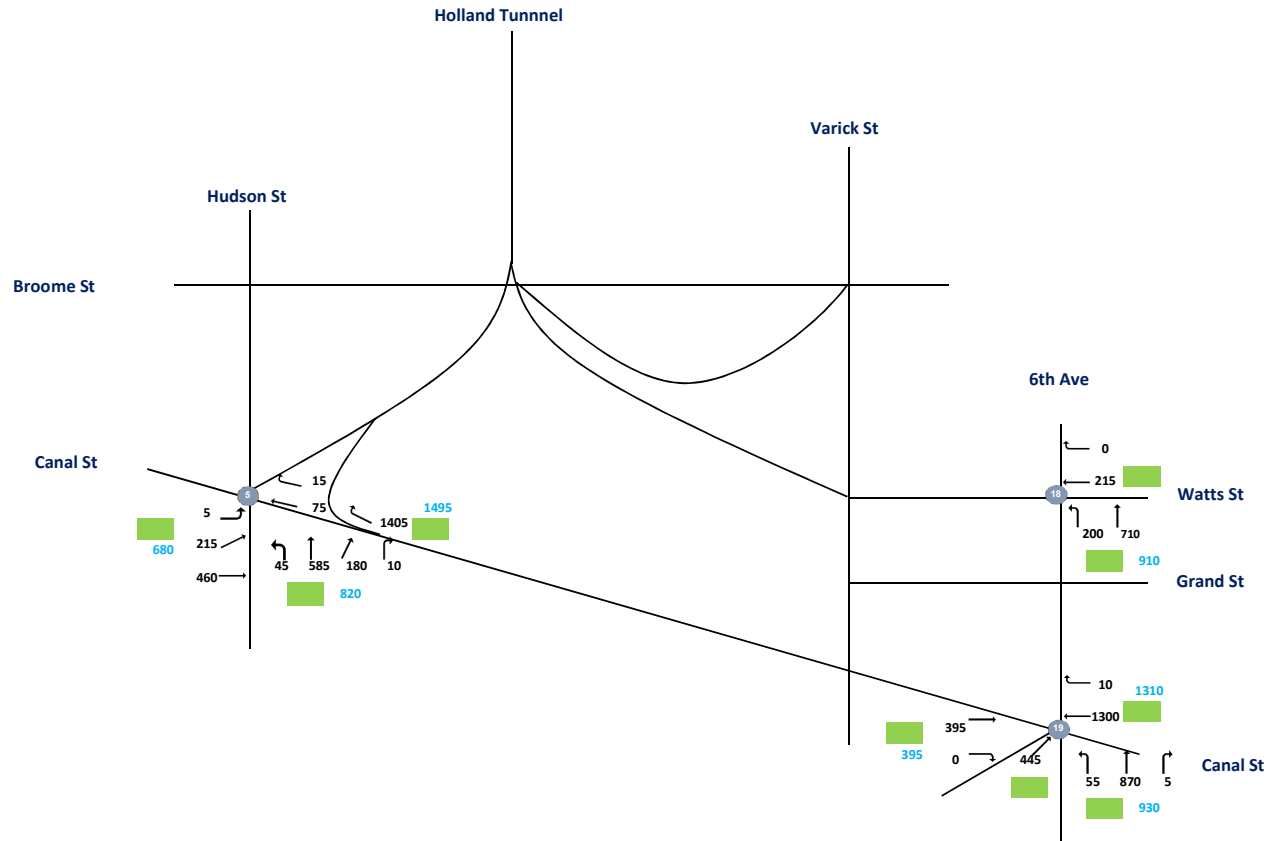

CBD Tolling
LM - Traffic Flowmap #4
PM Existing



- Legend:**
- 1 - Intersection (2019 Collected Data)
 - 7 - Intersection (Uncollected Data)
 - 100 - ATR Volume
 - 100 - Approach Volume

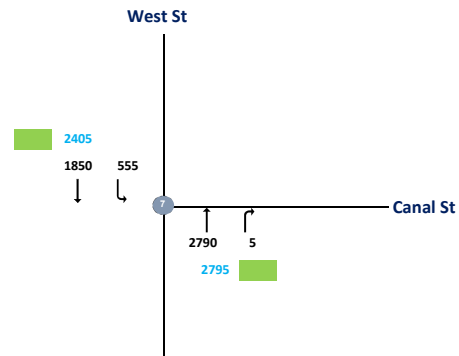

CBD Tolling
LM - Traffic Flowmap #5
PM Existing



- Legend:**
- 1 - Intersection (2019 Collected Data)
 - 7 - Intersection (Uncollected Data)
 - 100 - ATR Volume
 - 100 - Approach Volume

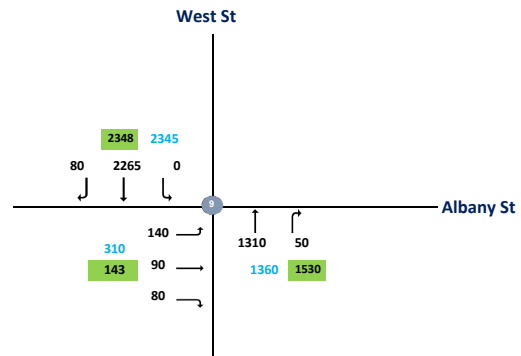

CBD Tolling
LM - Traffic Flowmap #6
PM Existing



- Legend:**
- 1 - Intersection (2019 Collected Data)
 - 7 - Intersection (Uncollected Data)
 - 100 - ATR Volume
 - 100 - Approach Volume
 - ↶ - Illegal movement

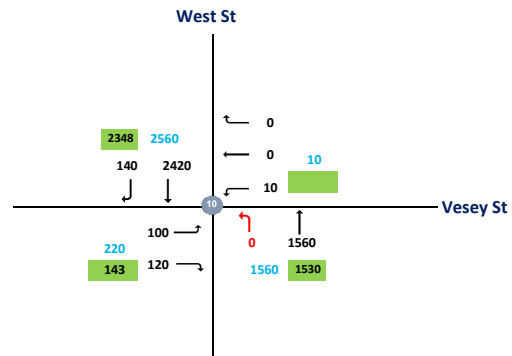

CBD Tolling
LM - Traffic Flowmap #7
PM Existing



- Legend:**
- 1 - Intersection (2019 Collected Data)
 - 7 - Intersection (Uncollected Data)
 - 100 - ATR Volume
 - 100 - Approach Volume

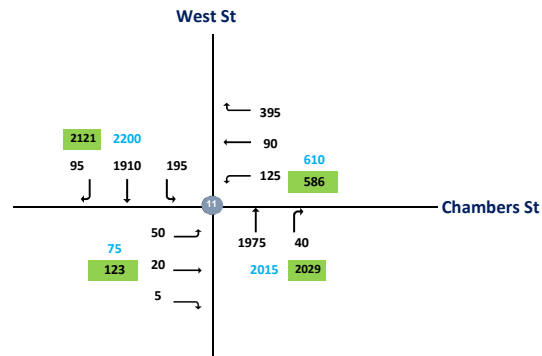

CBD Tolling
LM - Traffic Flowmap #8
PM Existing



- Legend:**
- 1 - Intersection (2019 Collected Data)
 - 7 - Intersection (Uncollected Data)
 - ATR Volume
 - 100 - Approach Volume

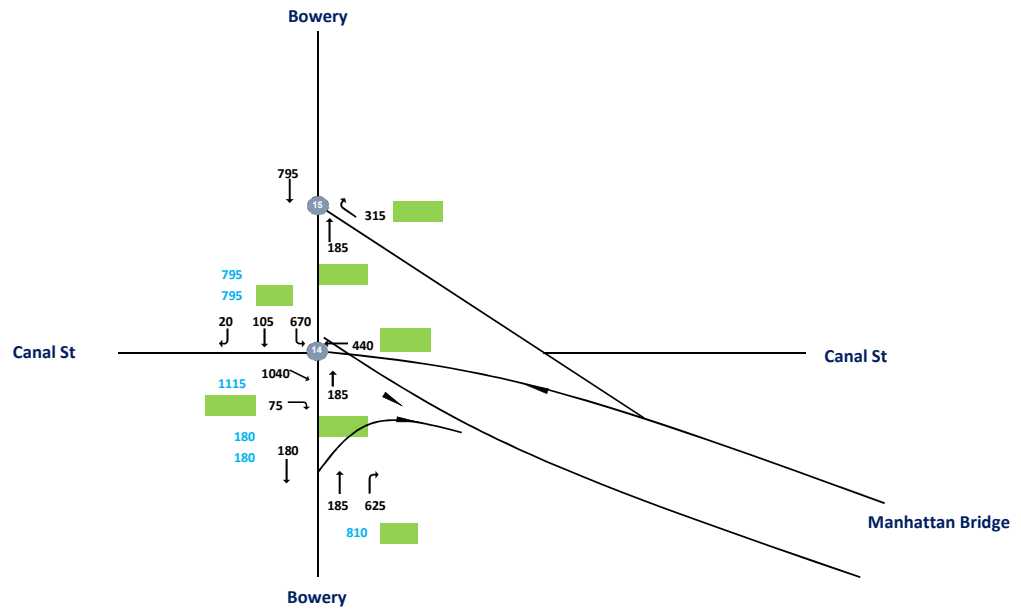

Intersection	Node	Approach	Total Vehicles					
			Inbound/Outbound					Total
			PM Peak Hour					
L2	L	T	R	R2				
Edgar St. and Trinity Pl. 2019 (TMC-010)	1							
Edgar St.	1	EB	0	55	0	0	0	
478 Exit Ramp.	1	NE	0	80	0	0	0	
Trinity Pl.	1	NB	0	15	125	0	0	
Trinity Pl.	1	SB	0	0	0	0	0	275
Rector St. and Trinity Pl. 2019 (TMC-011)	2							
Rector St.	2	EB	0	80	40	0	0	
Rector St.	2	WB	0	0	0	0	0	
Trinity Pl.	2	NB	0	0	225	35	0	
Trinity Pl.	2	SB	0	0	0	0	0	380
West St. and HCT Exit. 2019 (TMC-012)	3							
-	3	EB	0	0	0	0	0	
HCT Exit.	3	WB	0	350	0	0	0	
West St.	3	NB	0	0	575	0	1230	
West St.	3	SB	0	0	1295	0	0	3450
West St. and HCT Exit. 2019 (TMC-012)	333							
W. Thams St.	333	EB	0	0	0	0	0	
HCT Exit.	333	WB	0	0	0	510	0	
West St.	333	NB	0	0	575	0	0	
West St.	333	SB	0	0	1295	0	0	2380
Chambers St. and Centre St. 2018	4							
Chambers St.	4	EB	0	0	0	510	0	
-	4	WB	0	0	0	0	0	
Centre St.	4	NB	0	560	670	0	0	
Centre St.	4	SB	0	0	365	15	0	2120
Hudson St. and Canal St. 2018	5							
Canal St.	5	EB	5	215	460	0	0	
Canal St.	5	WB	0	0	75	15	0	
Hudson St.	5	NB	0	45	585	180	10	
Hudson St.	5	SB	0	0	0	0	0	1590

Hudson St. and Canal St.								
2018	555							
Canal St.	555	EB	0	0	470	0	0	
Canal St.	555	WB	0	0	90	1405	0	
Hudson St.	555	NB	0	0	0	0	0	
Hudson St.	555	SB	0	0	0	0	0	1965
West St. and Canal St N.								
2018	7							
Canal St N.	7	EB	0	0	0	0	0	
-	7	WB	0	0	0	0	0	
West St.	7	NB	0	0	2790	5	0	
West St.	7	SB	0	555	1850	0	0	5200
West St. and Canal St S.								
2018	777							
-	777	EB	0	0	0	0	0	
Canal St S.	777	WB	0	0	0	0	0	
West St.	777	NB	0	0	2790	0	0	
West St.	777	SB	0	0	2405	0	0	5195
West St. and Albany St.								
2019 (TMC-013)	9							
Albany St.	9	EB	0	140	90	80	0	
-	9	WB	0	0	0	0	0	
West St.	9	NB	0	0	1310	50	0	
West St.	9	SB	0	0	2265	80	0	4015
West St. and Vesey St.								
2019 (TMC-014)	10							
Vesey St.	10	EB	0	100	0	120	0	
Vesey St.	10	WB	0	10	0	0	0	
West St.	10	NB	0	0	1560	0	0	
West St.	10	SB	0	0	2420	140	0	275
West St. and Chambers St.								
2019 (TMC-015)	11							
Chambers St.	11	EB	0	50	20	5	0	
Chambers St.	11	WB	0	125	90	395	0	
West St.	11	NB	0	0	1975	40	0	
West St.	11	SB	0	195	1910	95	0	4900

Bowey and Canal St./Manhattan Bridge Off-Ramp								
2018	14							
Canal St.	14	EB	0	0	1040	75	0	
Manhattan Bridge Off-Ramp	14	WB	0	0	440	0	0	
Bowey	14	NB	0	0	185	625	0	
Bowey	14	SB	0	670	105	20	0	3160
Bowey and Manhattan Bridge Off-Ramp								
2018	15							
	15	EB						
Manhattan Bridge Off-Ramp	15	WB				315		
Bowey	15	NB			185			
Bowey	15	SB			795			1295
6th Ave. and Watts St								
2018	18							
Watts St	18	EB	0	0	0	0	0	
Watts St	18	WB	0	0	215	0	0	
6th Ave.	18	NB	0	200	710	0	0	
6th Ave.	18	SB	0	0	0	0	0	1125
6th Ave. and Canal St.								
2018	19							
Canal St.	19	EB	0	0	395	0	0	
Canal St.	19	WB	0	0	1300	10	0	
6th Ave.	19	NB	0	55	870	5	0	
Laight St.	19	NE	0	0	0	445	0	3080

CBD Tolling
LT #1 - Traffic Flowmap
AM Existing



- Legend:**
- ① - Intersection (2019 Collected Data)
 - ⑦ - Intersection (Pre-2019 Collected Data)
 - 100 - ATR Volume
 - 100 - Approach Volume

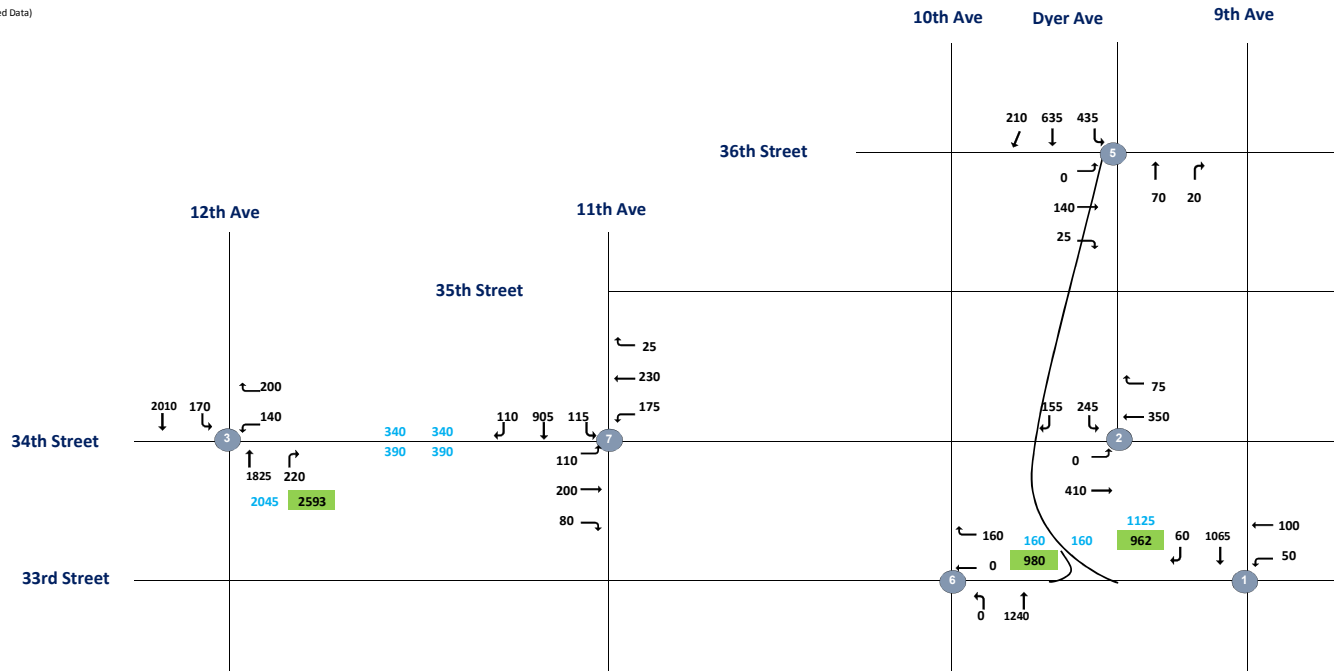

CBD Tolling
LT #2 - Traffic Flowmap
AM Existing



- Legend:**
- 1 - Intersection (2019 Collected Data)
 - 7 - Intersection (Pre-2019 Collected Data)
 - 100 - ATR Volume
 - 100 - Approach Volume

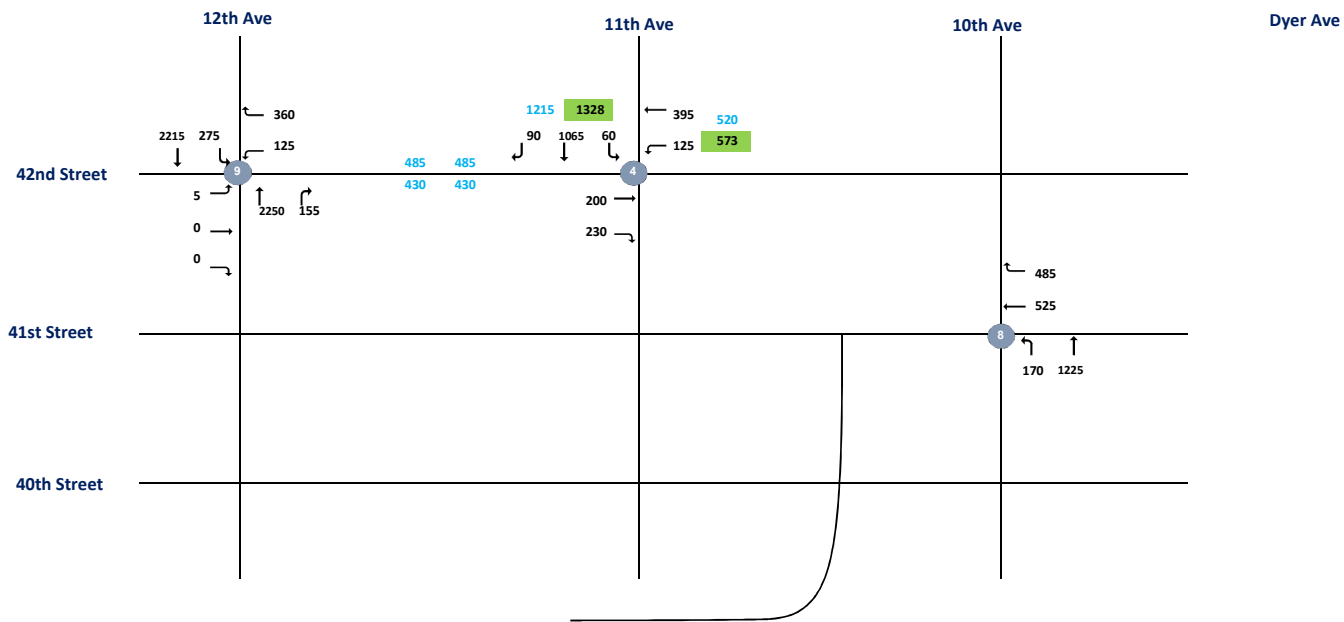

LT

8:00:00 AM

Intersection	Node	Approach	Total Vehicles					
			Inbound/Outbound					
			AM Peak Hour					
			L2	L	T	R	R2	Total
33rd Street and 9th Avenue 2019 (WRY-TMC-109)	1							
33rd Street	1	EB	0	0	0	0	0	
33rd Street	1	WB	0	50	100	0	0	
9th Avenue	1	NB	0	0	0	0	0	
9th Avenue	1	SB	0	0	1065	60	0	1275
34th Street and Dyer Avenue 2019 (WRY-TMC-105)	2							
34th Street	2	EB	0	0	410	0	0	
34th Street	2	WB	0	0	350	75	0	
Dyer Avenue	2	NB	0	0	0	0	0	
Dyer Avenue	2	SB	0	245	0	155	0	1235
34th Street and 12th Avenue 2019 (PABT-TMC-055)	3							
34th Street	3	EB	0	0	0	0	0	
34th Street	3	WB	0	140	0	200	0	
12th Avenue	3	NB	0	0	1825	220	0	
12th Avenue	3	SB	0	170	2010	0	0	4565
42nd Street and 11th Avenue 2019 (PABT-TMC-052)	4							
42nd Street	4	EB	0	0	200	230	0	
42nd Street	4	WB	0	125	395	0	0	
11th Avenue	4	NB	0	0	0	0	0	
11th Avenue	4	SB	0	60	1065	90	0	2165
36th Street and Dyer Avenue 2019 (PABT-TMC-060)	5							
36th Street	5	EB	0	0	140	25	0	
36th Street	5	WB	0	0	0	0	0	
Dyer Avenue	5	NB	0	0	70	20	0	
Dyer Avenue	5	SB	0	435	635	210	0	1535
33rd Street and 10th Avenue 2019 (WRY-TMC-108)	6							
33rd Street	6	EB	0	0	0	0	0	
33rd Street	6	WB	0	0	0	160	0	
10th Avenue	6	NB	0	0	1240	0	0	
10th Avenue	6	SB	0	0	0	0	0	1400

34th Street and 11th Avenue 2019 (PABT-TMC-044)	7								
34th Street	7	EB	0	110	200	80	0		
34th Street	7	WB	0	175	230	25	0		
11th Avenue	7	NB	0	0	0	0	0		
11th Avenue	7	SB	0	115	905	110	0		1950
34th Street and 11th Avenue 2019 (PABT-TMC-040)	8								
34th Street	8	EB	0	0	0	0	0		
34th Street	8	WB	0	0	525	485	0		
11th Avenue	8	NB	0	170	1225	0	0		
11th Avenue	8	SB	0	0	0	0	0		2405
42nd Street and 12th Avenue 2019 (PABT-TMC-057)	9								
42nd Street	9	EB	0	5	0	0	0		
42nd Street	9	WB	0	125	0	360	0		
12th Avenue	9	NB	0	0	2250	155	0		
12th Avenue	9	SB	0	275	2215	0	0		5385

CBD Tolling
LT #1 - Traffic Flowmap
MD Existing



- Legend:**
- ① - Intersection (2019 Collected Data)
 - ⑦ - Intersection (Pre-2019 Collected Data)
 - 100 - ATR Volume
 - 100 - Approach Volume

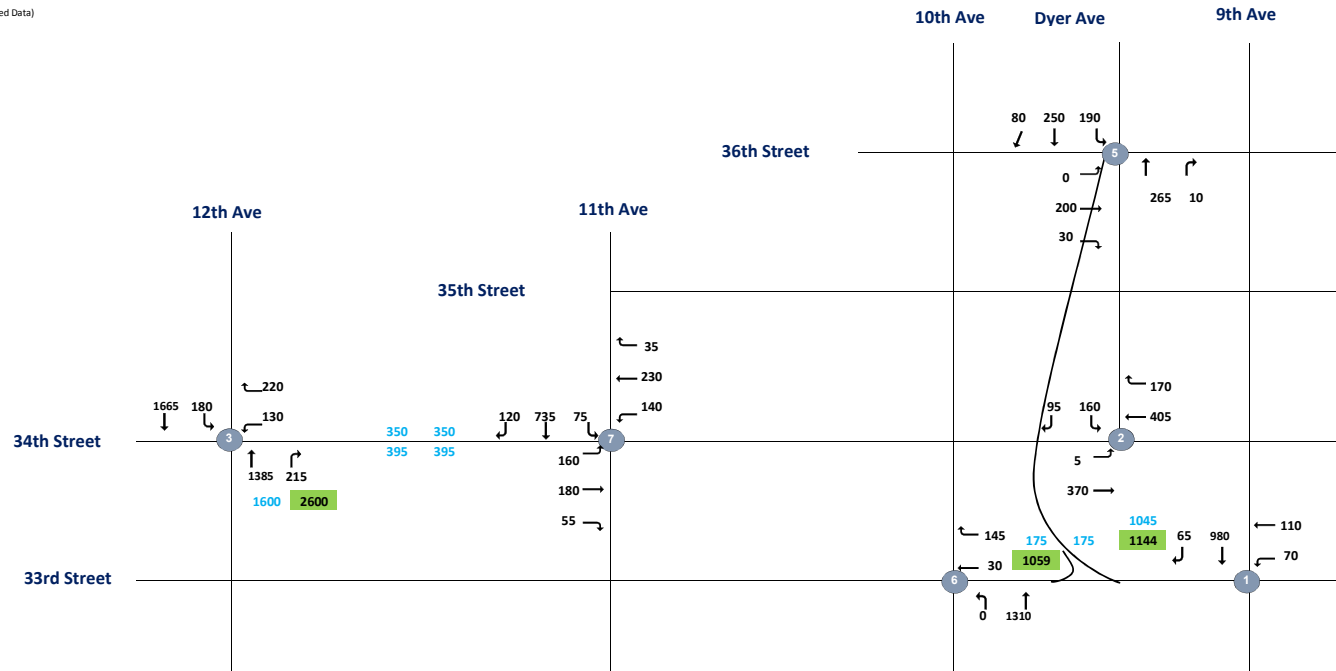

CBD Tolling
LT #2 - Traffic Flowmap
MD Existing



- Legend:**
- 1 - Intersection (2019 Collected Data)
 - 7 - Intersection (Pre-2019 Collected Data)
 - 100 - ATR Volume
 - 100 - Approach Volume

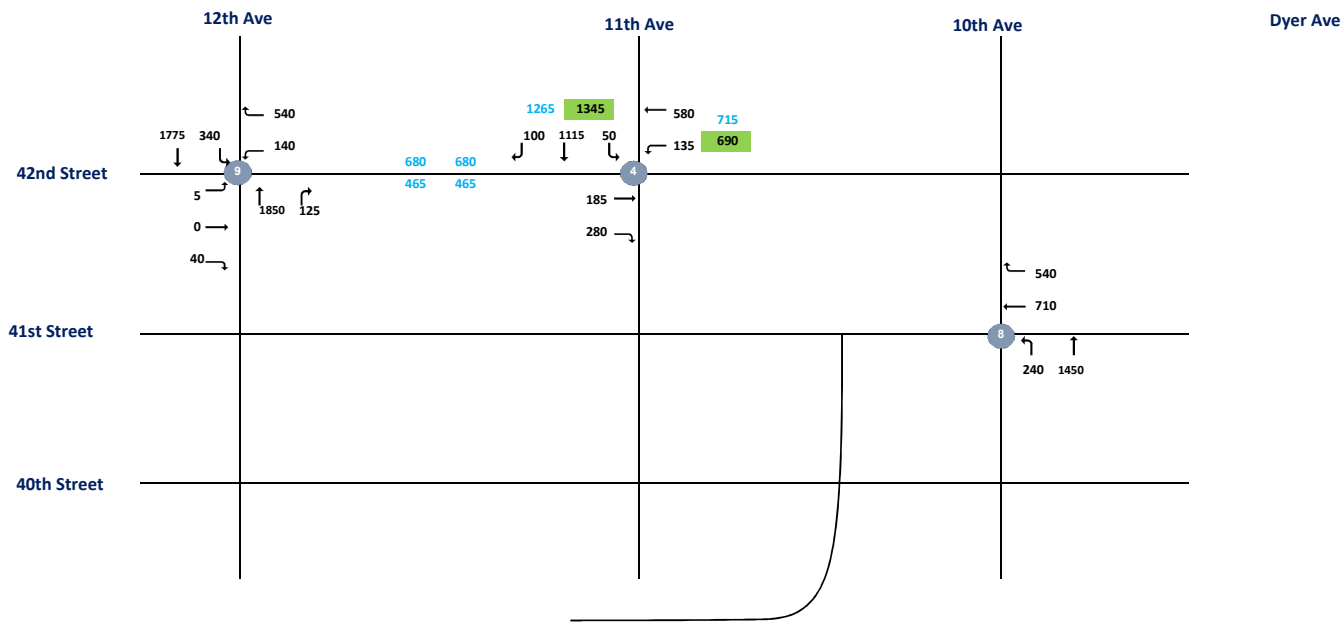

LT

1:00:00 PM

Intersection	Node	Approach	Total Vehicles					
			Inbound/Outbound					
			MD Peak Hour					
			L2	L	T	R	R2	Total
33rd Street and 9th Avenue 2019 (WRY-TMC-109)	1							
33rd Street	1	EB	0	0	0	0	0	
33rd Street	1	WB	0	70	110	0	0	
9th Avenue	1	NB	0	0	0	0	0	
9th Avenue	1	SB	0	0	980	65	0	1225
34th Street and Dyer Avenue 2019 (WRY-TMC-105)	2							
34th Street	2	EB	0	5	370	0	0	
34th Street	2	WB	0	0	405	170	0	
Dyer Avenue	2	NB	0	0	0	0	0	
Dyer Avenue	2	SB	0	160	0	95	0	1205
34th Street and 12th Avenue 2019 (PABT-TMC-055)	3							
34th Street	3	EB	0	0	0	0	0	
34th Street	3	WB	0	130	0	220	0	
12th Avenue	3	NB	0	0	1385	215	0	
12th Avenue	3	SB	0	180	1665	0	0	3795
42nd Street and 11th Avenue 2019 (PABT-TMC-052)	4							
42nd Street	4	EB	0	0	185	280	0	
42nd Street	4	WB	0	135	580	0	0	
11th Avenue	4	NB	0	0	0	0	0	
11th Avenue	4	SB	0	50	1115	100	0	2445
36th Street and Dyer Avenue 2019 (PABT-TMC-060)	5							
36th Street	5	EB	0	0	200	30	0	
36th Street	5	WB	0	0	0	0	0	
Dyer Avenue	5	NB	0	0	265	10	0	
Dyer Avenue	5	SB	0	190	250	80	0	1025
33rd Street and 10th Avenue 2019 (WRY-TMC-108)	6							
33rd Street	6	EB	0	0	0	0	0	
33rd Street	6	WB	0	0	30	145	0	
10th Avenue	6	NB	0	0	1310	0	0	
10th Avenue	6	SB	0	0	0	0	0	1485

34th Street and 11th Avenue 2019 (PABT-TMC-044)	7								
34th Street	7	EB	0	160	180	55	0		
34th Street	7	WB	0	140	230	35	0		
11th Avenue	7	NB	0	0	0	0	0		
11th Avenue	7	SB	0	75	735	120	0		1730
34th Street and 11th Avenue 2019 (PABT-TMC-040)	8								
34th Street	8	EB	0	0	0	0	0		
34th Street	8	WB	0	0	710	540	0		
11th Avenue	8	NB	0	240	1450	0	0		
11th Avenue	8	SB	0	0	0	0	0		2940
42nd Street and 12th Avenue 2019 (PABT-TMC-057)	9								
42nd Street	9	EB	0	5	0	40	0		
42nd Street	9	WB	0	140	0	540	0		
12th Avenue	9	NB	0	0	1850	125	0		
12th Avenue	9	SB	0	340	1775	0	0		4815

CBD Tolling
LT #1 - Traffic Flowmap
PM Existing



- Legend:**
- ① - Intersection (2019 Collected Data)
 - ⑦ - Intersection (Pre-2019 Collected Data)
 - 100 - ATR Volume
 - 100 - Approach Volume

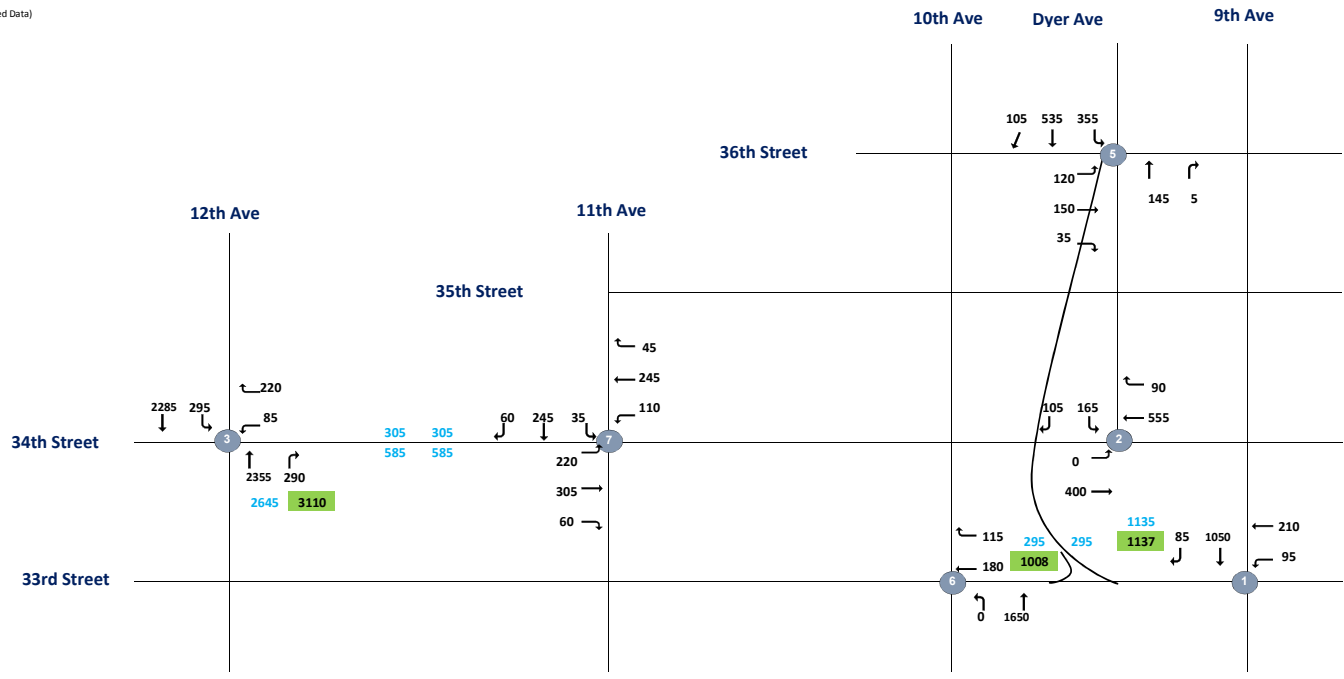

CBD Tolling
LT #2 - Traffic Flowmap
PM Existing



- Legend:**
- ① - Intersection (2019 Collected Data)
 - ⑦ - Intersection (Pre-2019 Collected Data)
 - 100 - ATR Volume
 - 100 - Approach Volume

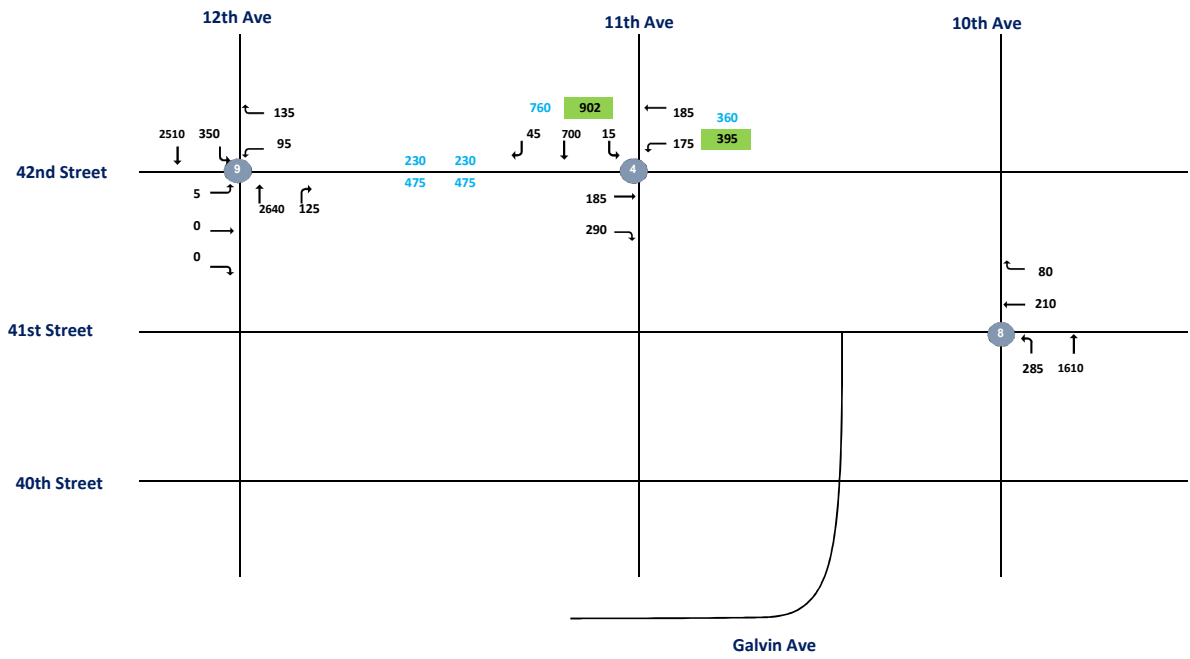

LT

5:00:00 PM

Intersection	Node	Approach	Total Vehicles					
			Inbound/Outbound					
			PM Peak Hour					
			L2	L	T	R	R2	Total
33rd Street and 9th Avenue 2019 (WRY-TMC-109)	1							
33rd Street	1	EB	0	0	0	0	0	
33rd Street	1	WB	0	95	210	0	0	
9th Avenue	1	NB	0	0	0	0	0	
9th Avenue	1	SB	0	0	1050	85	0	1440
34th Street and Dyer Avenue 2019 (WRY-TMC-105)	2							
34th Street	2	EB	0	0	400	0	0	
34th Street	2	WB	0	0	555	90	0	
Dyer Avenue	2	NB	0	0	0	0	0	
Dyer Avenue	2	SB	0	165	0	105	0	1315
34th Street and 12th Avenue 2019 (PABT-TMC-055)	3							
34th Street	3	EB	0	0	0	0	0	
34th Street	3	WB	0	85	0	220	0	
12th Avenue	3	NB	0	0	2355	290	0	
12th Avenue	3	SB	0	295	2285	0	0	5530
42nd Street and 11th Avenue 2019 (PABT-TMC-052)	4							
42nd Street	4	EB	0	0	185	290	0	
42nd Street	4	WB	0	175	185	0	0	
11th Avenue	4	NB	0	0	0	0	0	
11th Avenue	4	SB	0	15	700	45	0	1595
36th Street and Dyer Avenue 2019 (PABT-TMC-060)	5							
36th Street	5	EB	0	120	150	35	0	
36th Street	5	WB	0	0	0	0	0	
Dyer Avenue	5	NB	0	0	145	5	0	
Dyer Avenue	5	SB	0	355	535	105	0	1450
33rd Street and 10th Avenue 2019 (WRY-TMC-108)	6							
33rd Street	6	EB	0	0	0	0	0	
33rd Street	6	WB	0	0	180	115	0	
10th Avenue	6	NB	0	0	1650	0	0	
10th Avenue	6	SB	0	0	0	0	0	1945

34th Street and 11th Avenue 2019 (PABT-TMC-044)	7								
34th Street	7	EB	0	220	305	60	0		
34th Street	7	WB	0	110	245	45	0		
11th Avenue	7	NB	0	0	0	0	0		
11th Avenue	7	SB	0	35	245	60	0		1325
34th Street and 11th Avenue 2019 (PABT-TMC-040)	8								
34th Street	8	EB	0	0	0	0	0		
34th Street	8	WB	0	0	210	80	0		
11th Avenue	8	NB	0	285	1610	0	0		
11th Avenue	8	SB	0	0	0	0	0		2185
42nd Street and 12th Avenue 2019 (PABT-TMC-057)	9								
42nd Street	9	EB	0	5	0	0	0		
42nd Street	9	WB	0	95	0	135	0		
12th Avenue	9	NB	0	0	2640	125	0		
12th Avenue	9	SB	0	350	2510	0	0		5860

**New Jersey
2019 Existing Conditions
AM Peak Hour**

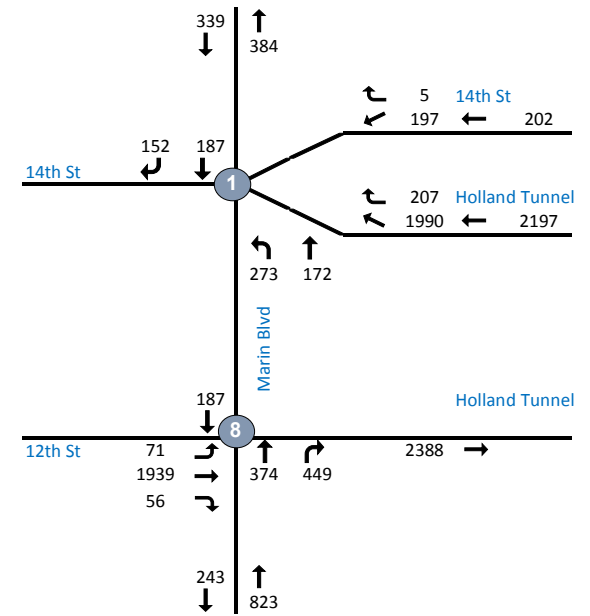
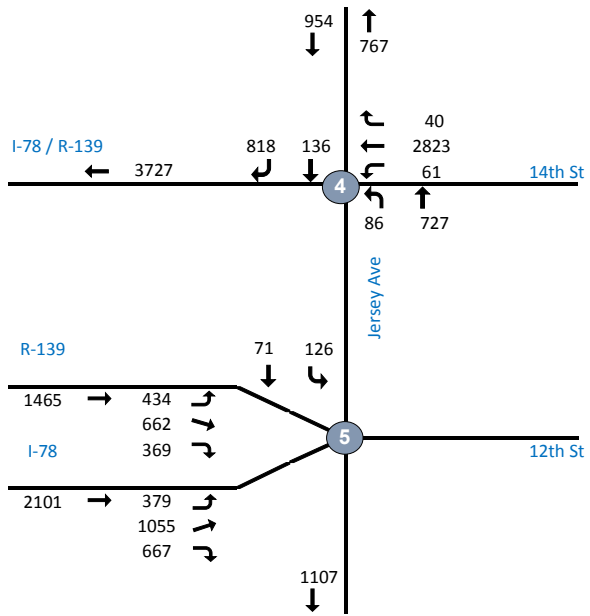

Intersection	Node	Approach	Total Vehicles						Total
			Inbound/Outbound						
			L2	L	T	R	R2		
14th Street (E-W) & Jersey Avenue (N-S)									
NJ-TMC-007.xlsx									
n/a	4	EB	0	0	0	0	0		
14th Street	4	WB	0	61	2823	40	0		
Jersey Avenue	4	NB	0	86	727	0	0		
Jersey Avenue	4	SB	0	0	136	818	0	4691	
14th Street/Holland Tunnel (E-W) & Marin Boulevard (N-S)									
NJ-TMC-008.xlsx									
Holland Tunnel	1	WB	0	0	1990	207	0		
14th Street	1	SW	0	0	0	197	5		
Marin Boulevard	1	NB	0	273	172	0	0		
Marin Boulevard	1	SB	0	0	187	152	0	3183	
12th Street (E-W) & Jersey Avenue (N-S)									
NJ-TMC-009.xlsx	5								
R-139	5	SE	434	662	0	369	0		
I-78	5	EB	0	379	1055	667	0		
Jersey Avenue	5	NB	0	0	0	0	0		
Jersey Avenue	5	SB	0	126	71	0	0	3763	
12th Street (E-W) & Marin Blvd (N-S)									
NJ-TMC-010.xlsx	8								
12th Street/Holland Tunnel	8	EB	0	71	1939	56	0		
n/a	8	WB	0	0	0	0	0		
Marin Boulevard	8	NB	0	0	374	449	0		
Marin Boulevard	8	SB	0	0	187	0	0	3076	

**New Jersey
2019 Existing Conditions
MD Peak Hour**

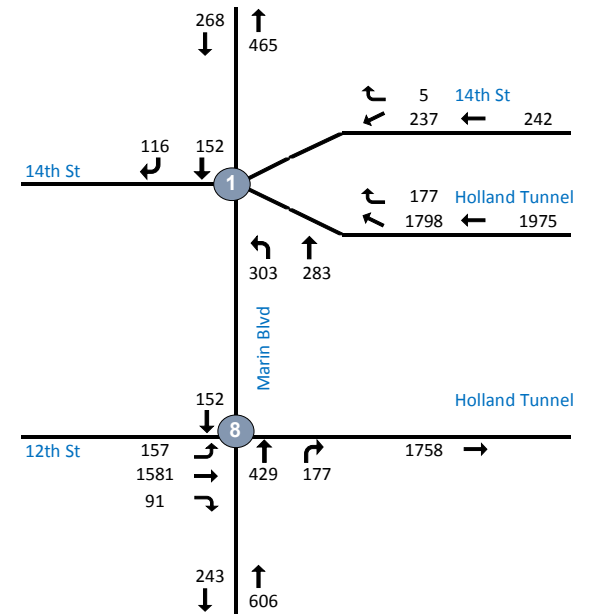
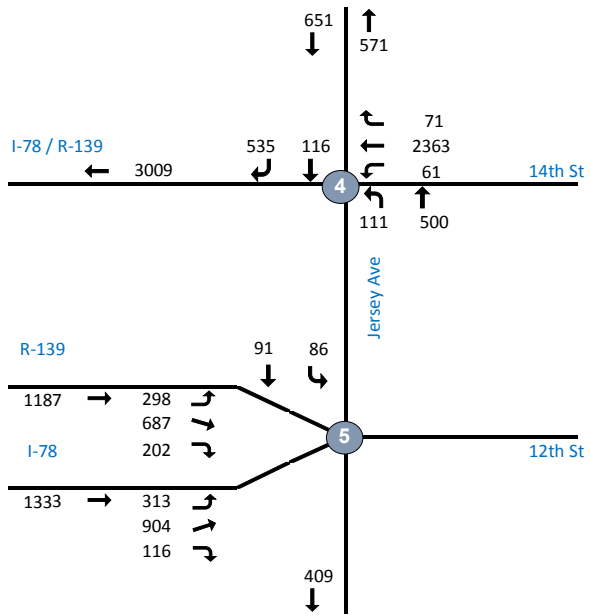

Intersection	Node	Approach	Total Vehicles					
			Inbound/Outbound					Total
			L2	L	T	R	R2	
14th Street (E-W) & Jersey Avenue (N-S)								
NJ-TMC-007.xlsx								
n/a	4	EB	0	0	0	0	0	
14th Street	4	WB	0	61	2363	71	0	
Jersey Avenue	4	NB	0	111	500	0	0	
Jersey Avenue	4	SB	0	0	116	535	0	3757
14th Street/Holland Tunnel (E-W) & Marin Boulevard (N-S)								
NJ-TMC-008.xlsx								
Holland Tunnel	1	WB	0	0	1798	177	0	
14th Street	1	SW	0	0	0	237	5	
Marin Boulevard	1	NB	0	303	283	0	0	
Marin Boulevard	1	SB	0	0	152	116	0	3071
12th Street (E-W) & Jersey Avenue (N-S)								
NJ-TMC-009.xlsx	5							
R-139	5	SE	298	687	0	202	0	
I-78	5	EB	0	313	904	116	0	
Jersey Avenue	5	NB	0	0	0	0	0	
Jersey Avenue	5	SB	0	86	91	0	0	2697
12th Street (E-W) & Marin Blvd (N-S)								
NJ-TMC-010.xlsx	8							
12th Street/Holland Tunnel	8	EB	0	157	1581	91	0	
n/a	8	WB	0	0	0	0	0	
Marin Boulevard	8	NB	0	0	429	177	0	
Marin Boulevard	8	SB	0	0	152	0	0	2587

**New Jersey
2019 Existing Conditions
PM Peak Hour**

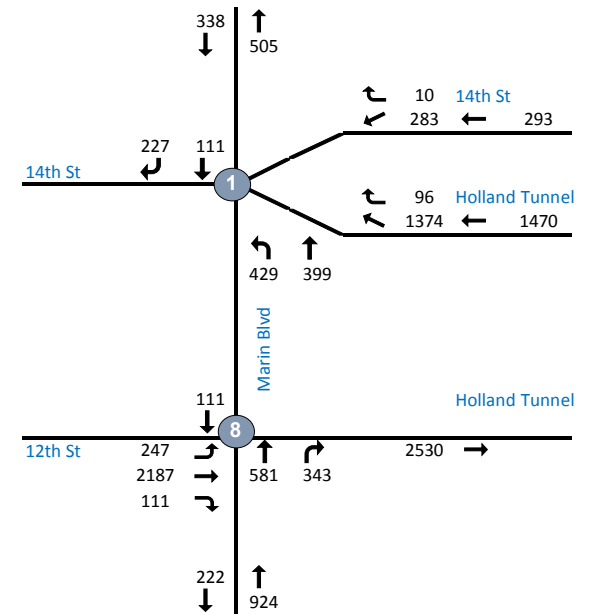
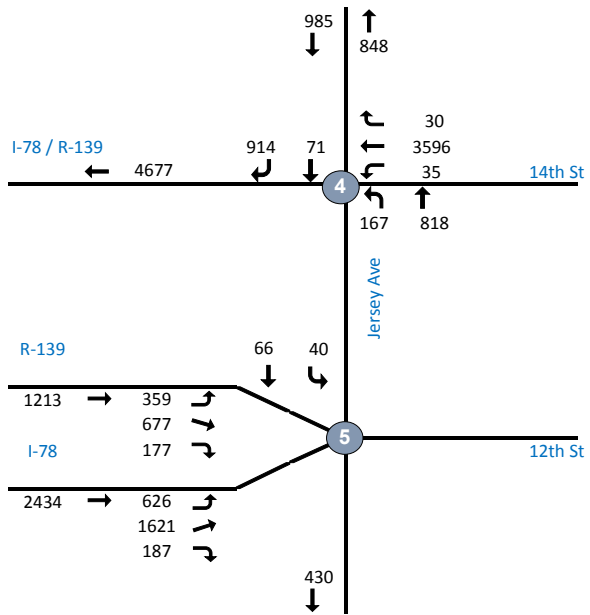

Intersection	Node	Approach	Total Vehicles					
			Inbound/Outbound					Total
			L2	L	T	R	R2	
14th Street (E-W) & Jersey Avenue (N-S)								
NJ-TMC-007.xlsx								
n/a	4	EB	0	0	0	0	0	
14th Street	4	WB	0	35	3596	30	0	
Jersey Avenue	4	NB	0	167	818	0	0	
Jersey Avenue	4	SB	0	0	71	914	0	5631
14th Street/Holland Tunnel (E-W) & Marin Boulevard (N-S)								
NJ-TMC-008.xlsx								
Holland Tunnel	1	WB	0	0	1374	96	0	
14th Street	1	SW	0	0	0	283	10	
Marin Boulevard	1	NB	0	429	399	0	0	
Marin Boulevard	1	SB	0	0	111	227	0	2929
12th Street (E-W) & Jersey Avenue (N-S)								
NJ-TMC-009.xlsx	5							
R-139	5	SE	359	677	0	177	0	
I-78	5	EB	0	626	1621	187	0	
Jersey Avenue	5	NB	0	0	0	0	0	
Jersey Avenue	5	SB	0	40	66	0	0	3753
12th Street (E-W) & Marin Blvd (N-S)								
NJ-TMC-010.xlsx	8							
12th Street/Holland Tunnel	8	EB	0	247	2187	111	0	
n/a	8	WB	0	0	0	0	0	
Marin Boulevard	8	NB	0	0	581	343	0	
Marin Boulevard	8	SB	0	0	111	0	0	3580

CBD Tolling
QMT - Traffic Flowmap
AM Existing



- Legend:**
- ① - Intersection (2019 Collected Data)
 - ⑦ - Intersection (Uncollected Data)
 - 100 - ATR Volume
 - 100 - Approach Volume

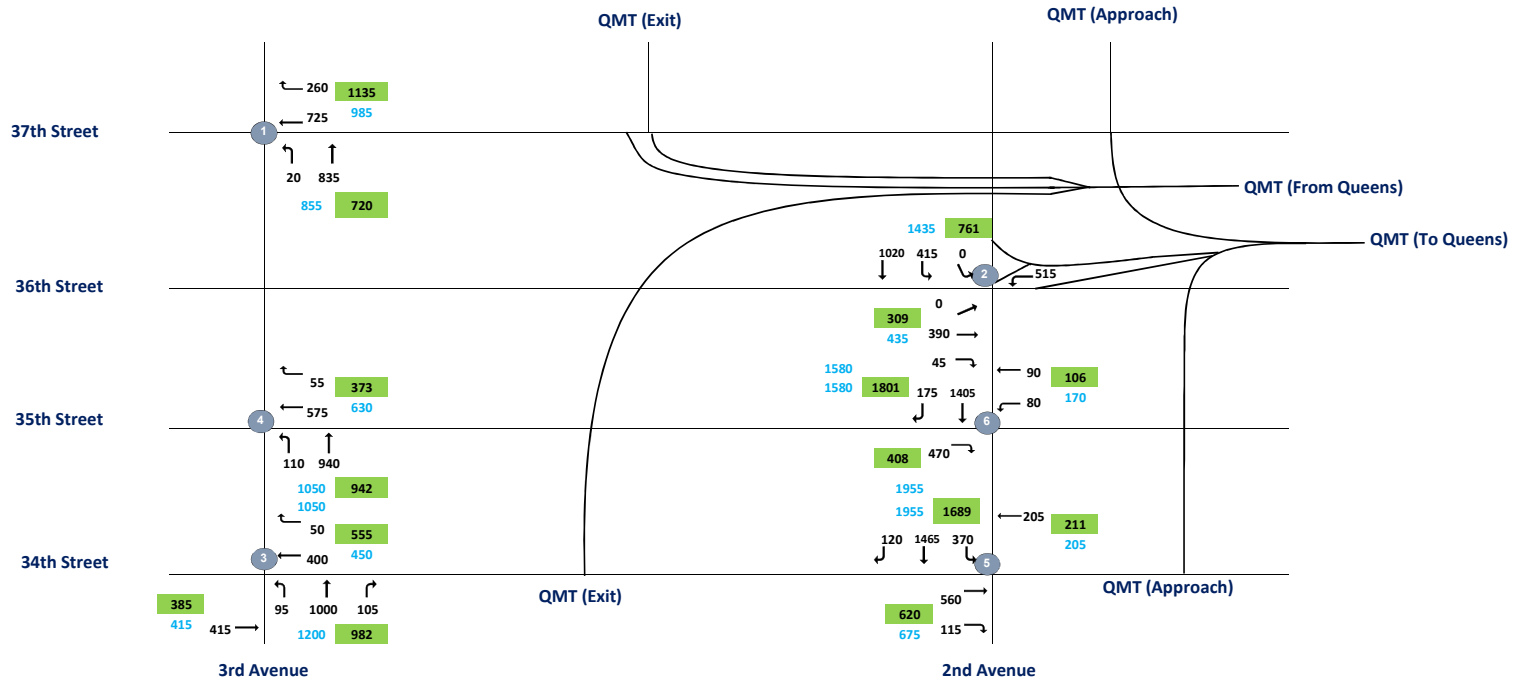

QM

8:00:00 AM

Intersection	Node	Approach	Total Vehicles						
			Inbound/Outbound						
			AM Peak Hour						
			L2	L	T	R	R2	Total	
37th St & 3rd Ave 2019 (TMC-016)	1								
37th St	1	EB	0	0	0	0	0		
37th St	1	WB	0	0	725	260	0		
3rd Ave	1	NB	0	20	835	0	0		
3rd Ave	1	SB	0	0	0	0	0		1840
36th St & 2nd Ave 2019 (TMC-017)	2								
36th St	2	EB	0	0	390	45	0		
36th St	2	WB	0	515	0	0	0		
2nd Ave	2	NB	0	0	0	0	0		
2nd Ave	2	SB	0	415	1020	0	0		2385
34th St & 3rd Ave 2019 (TMC-018)	3								
34th St	3	EB	0	0	415	0	0		
34th St	3	WB	0	0	400	50	0		
3rd Ave	3	NB	0	95	1000	105	0		
3rd Ave	3	SB	0	0	0	0	0		2065
35th St & 3rd Ave 2019 (TMC-019)	4								
35th St	4	EB	0	0	0	0	0		
35th St	4	WB	0	0	575	55	0		
3rd Ave	4	NB	0	110	940	0	0		
3rd Ave	4	SB	0	0	0	0	0		1680
34th St & 2nd Ave 2019 (TMC-020)	5								
34th St	5	EB	0	0	560	115	0		
34th St	5	WB	0	0	205	0	0		
2nd Ave	5	NB	0	0	0	0	0		
2nd Ave	5	SB	0	370	1465	120	0		2835
35th St & 2nd Ave 2019 (TMC-021)	6								
35th St	6	EB	0	0	0	470	0		
35th St	6	WB	0	80	90	0	0		
2nd Ave	6	NB	0	0	0	0	0		
2nd Ave	6	SB	0	0	1405	175	0		2220

CBD Tolling
QMT - Traffic Flowmap
MD Existing



- Legend:**
- 1 - Intersection (2019 Collected Data)
 - 7 - Intersection (Uncollected Data)
 - 100 - ATR Volume
 - 100 - Approach Volume

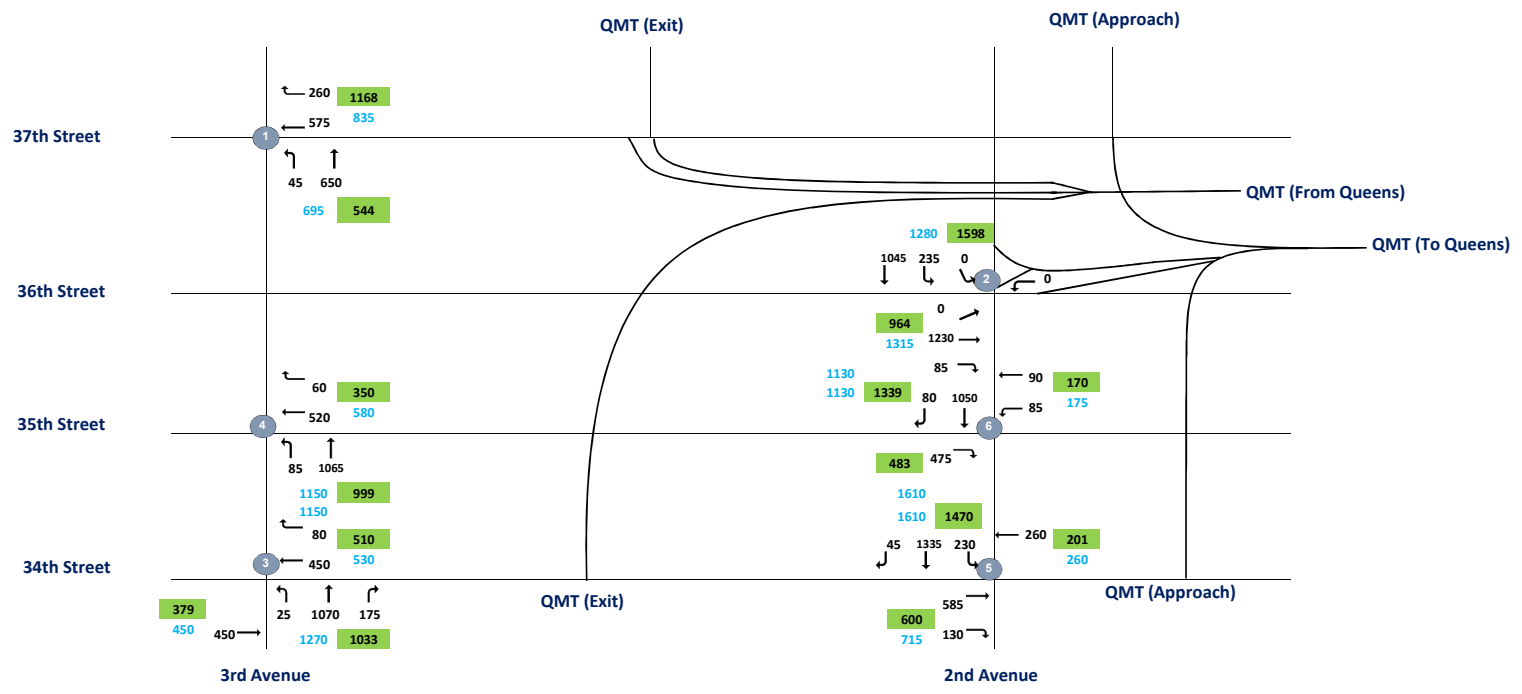

QM

1:00:00 PM

Intersection	Node	Approach	Total Vehicles					
			Inbound/Outbound					
			MD Peak Hour					
			L2	L	T	R	R2	Total
37th St & 3rd Ave 2019 (TMC-016)	1							
37th St	1	EB	0	0	0	0	0	
37th St	1	WB	0	0	575	260	0	
3rd Ave	1	NB	0	45	650	0	0	
3rd Ave	1	SB	0	0	0	0	0	1530
36th St & 2nd Ave 2019 (TMC-017)	2							
36th St	2	EB	0	0	1230	85	0	
36th St	2	WB	0	0	0	0	0	
2nd Ave	2	NB	0	0	0	0	0	
2nd Ave	2	SB	0	235	1045	0	0	2595
34th St & 3rd Ave 2019 (TMC-018)	3							
34th St	3	EB	0	0	450	0	0	
34th St	3	WB	0	0	450	80	0	
3rd Ave	3	NB	0	25	1070	175	0	
	3	SB	0	0	0	0	0	2250
35th St & 3rd Ave 2019 (TMC-019)	4							
35th St	4	EB	0	0	0	0	0	
35th St	4	WB	0	0	520	60	0	
3rd Ave	4	NB	0	85	1065	0	0	
	4	SB	0	0	0	0	0	1730
34th St & 2nd Ave 2019 (TMC-020)	5							
34th St	5	EB	0	0	585	130	0	
34th St	5	WB	0	0	260	0	0	
2nd Ave	5	NB	0	0	0	0	0	
2nd Ave	5	SB	0	230	1335	45	0	2585
35th St & 2nd Ave 2019 (TMC-021)	6							
35th St	6	EB	0	0	0	475	0	
35th St	6	WB	0	85	90	0	0	
2nd Ave	6	NB	0	0	0	0	0	
2nd Ave	6	SB	0	0	1050	80	0	1780

CBD Tolling
QMT - Traffic Flowmap
PM Existing



- Legend:**
- 1 - Intersection (2019 Collected Data)
 - 7 - Intersection (Uncollected Data)
 - 100 - ATR Volume
 - 100 - Approach Volume

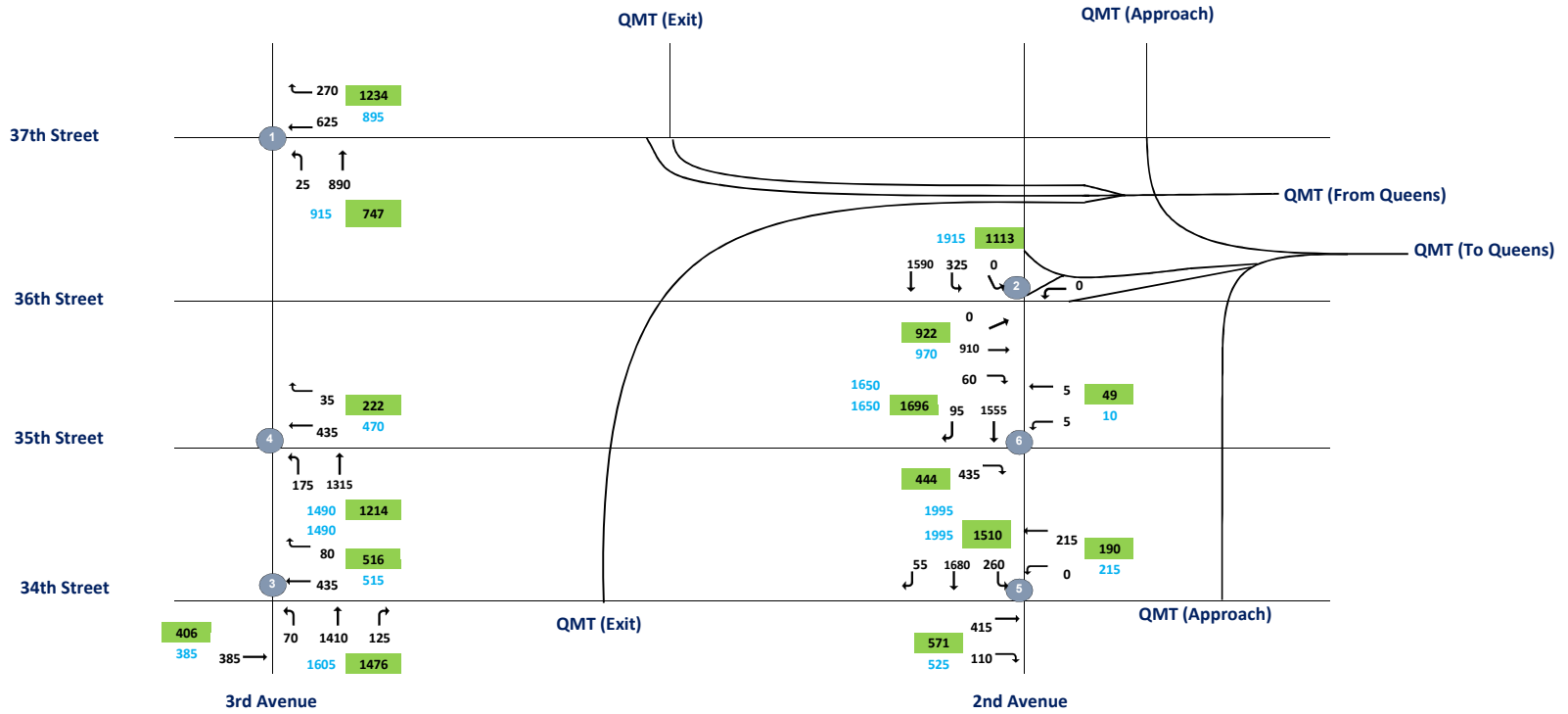

QM

5:00:00 PM

Intersection	Node	Approach	Total Vehicles					
			Inbound/Outbound					
			PM Peak Hour					
			L2	L	T	R	R2	Total
37th St & 3rd Ave 2019 (TMC-016)	1							
37th St	1	EB	0	0	0	0	0	
37th St	1	WB	0	0	625	270	0	
3rd Ave	1	NB	0	25	890	0	0	
3rd Ave	1	SB	0	0	0	0	0	1810
36th St & 2nd Ave 2019 (TMC-017)	2							
36th St	2	EB	0	0	910	60	0	
36th St	2	WB	0	0	0	0	0	
2nd Ave	2	NB	0	0	0	0	0	
2nd Ave	2	SB	0	325	1590	0	0	2885
34th St & 3rd Ave 2019 (TMC-018)	3							
34th St	3	EB	0	0	385	0	0	
34th St	3	WB	0	0	435	80	0	
3rd Ave	3	NB	0	70	1410	125	0	
	3	SB	0	0	0	0	0	2505
35th St & 3rd Ave 2019 (TMC-019)	4							
35th St	4	EB	0	0	0	0	0	
35th St	4	WB	0	0	435	35	0	
3rd Ave	4	NB	0	175	1315	0	0	
	4	SB	0	0	0	0	0	1960
34th St & 2nd Ave 2019 (TMC-020)	5							
34th St	5	EB	0	0	415	110	0	
34th St	5	WB	0	0	215	0	0	
2nd Ave	5	NB	0	0	0	0	0	
2nd Ave	5	SB	0	260	1680	55	0	2735
35th St & 2nd Ave 2019 (TMC-021)	6							
35th St	6	EB	0	0	0	435	0	
35th St	6	WB	0	5	5	0	0	
2nd Ave	6	NB	0	0	0	0	0	
2nd Ave	6	SB	0	0	1555	95	0	2095

CBD Tolling
QMT - Traffic Flowmap
LN Existing



- Legend:**
- 1 - Intersection (2019 Collected Data)
 - 7 - Intersection (Uncollected Data)
 - 100 - ATR Volume
 - 100 - Approach Volume

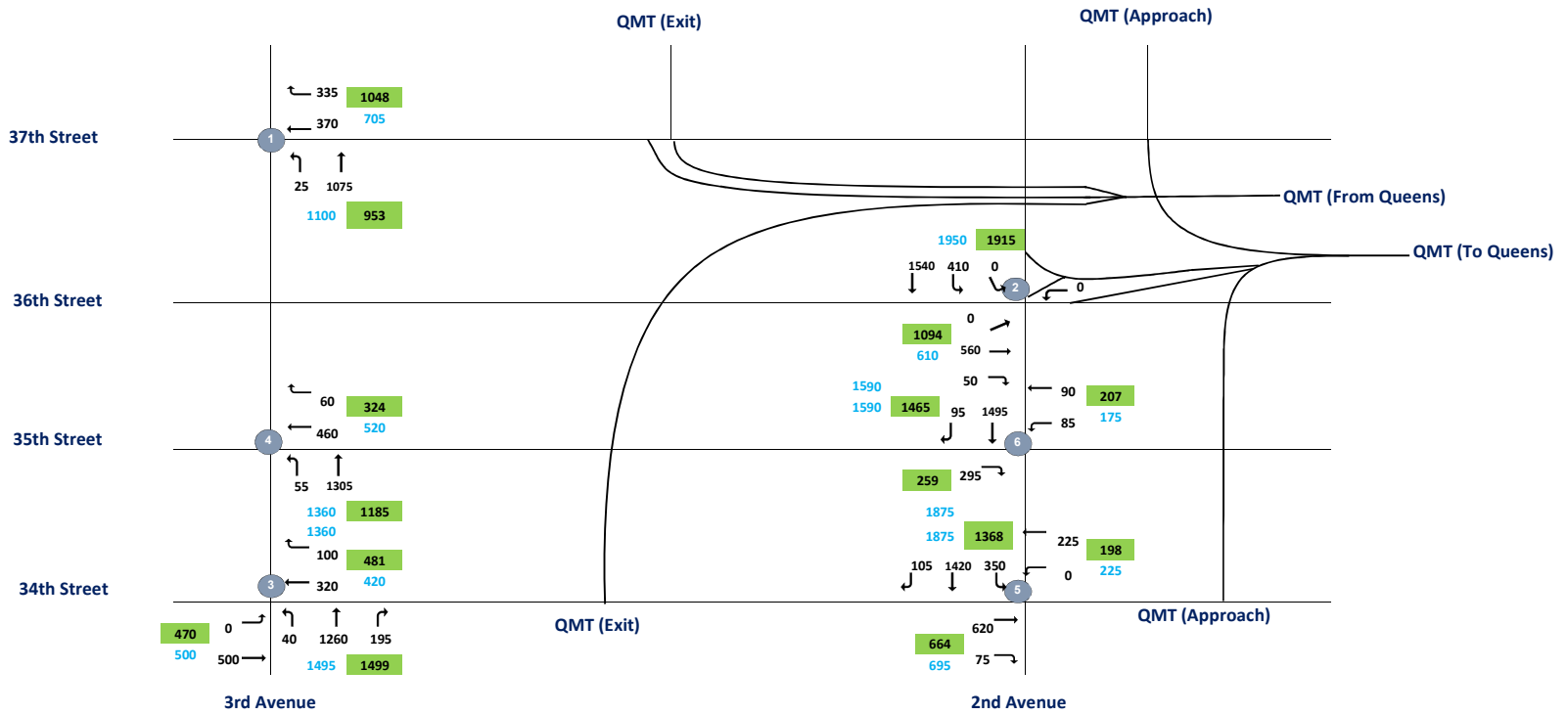

QM

9:00:00 PM

Intersection	Node	Approach	Total Vehicles					
			Inbound/Outbound					Total
			L2	L	T	R	R2	
37th St & 3rd Ave 2019 (TMC-016)	1							
37th St	1	EB	0	0	0	0	0	
37th St	1	WB	0	0	370	335	0	
3rd Ave	1	NB	0	25	1075	0	0	
3rd Ave	1	SB	0	0	0	0	0	1805
36th St & 2nd Ave 2019 (TMC-017)	2							
36th St	2	EB	0	0	560	50	0	
36th St	2	WB	0	0	0	0	0	
2nd Ave	2	NB	0	0	0	0	0	
2nd Ave	2	SB	0	410	1540	0	0	2560
34th St & 3rd Ave 2019 (TMC-018)	3							
34th St	3	EB	0	0	500	0	0	
34th St	3	WB	0	0	320	100	0	
3rd Ave	3	NB	0	40	1260	195	0	
3rd Ave	3	SB	0	0	0	0	0	2415
35th St & 3rd Ave 2019 (TMC-019)	4							
35th St	4	EB	0	0	0	0	0	
35th St	4	WB	0	0	460	60	0	
3rd Ave	4	NB	0	55	1305	0	0	
3rd Ave	4	SB	0	0	0	0	0	1880
34th St & 2nd Ave 2019 (TMC-020)	5							
34th St	5	EB	0	0	620	75	0	
34th St	5	WB	0	0	225	0	0	
2nd Ave	5	NB	0	0	0	0	0	
2nd Ave	5	SB	0	350	1420	105	0	2795
35th St & 2nd Ave 2019 (TMC-021)	6							
35th St	6	EB	0	0	0	295	0	
35th St	6	WB	0	85	90	0	0	
2nd Ave	6	NB	0	0	0	0	0	
2nd Ave	6	SB	0	0	1495	95	0	2060

CBD Tolling
RKB - Traffic Flowmap
AM Existing



- Legend:**
- ① - Intersection (2019 Collected Data)
 - ⑦ - Intersection (Uncollected Data)
 - 100 - ATR Volume
 - 100 - Approach Volume

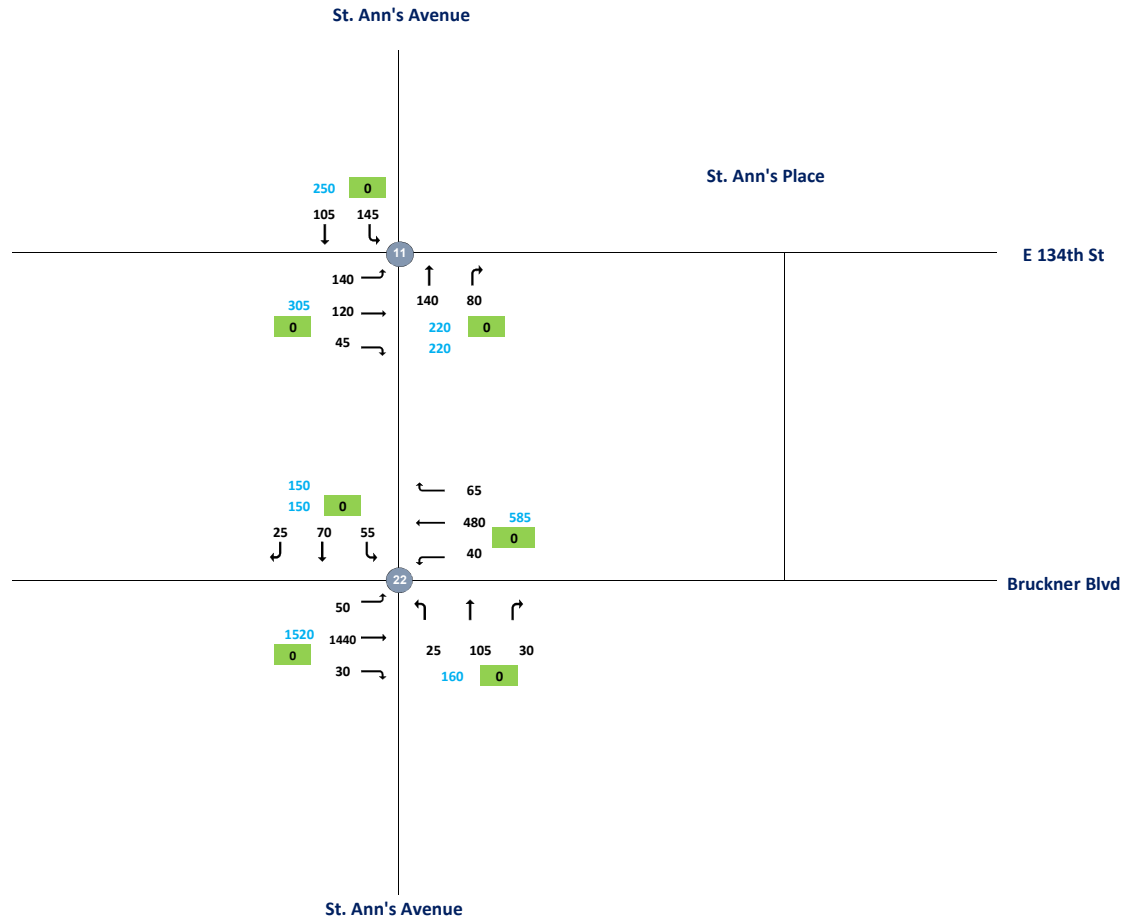

RKB

8:00 AM

Intersection	Node	Approach	Total Vehicles					
			Inbound/Outbound					Total
			AM Peak Hour					
L2	L	T	R	R2				
E 134th Street and St. Ann's Ave 2019 (TMC-060)	11							
E 134th Street	11	EB	0	140	120	45	0	
E 134th Street	11	WB	0	0	0	0	0	
St. Ann's Ave	11	NB	0	0	140	80	0	
St. Ann's Ave	11	SB	0	145	105	0	0	775
Bruckner Blvd and St. Ann's Ave 2019 (TMC-061)	22							
Bruckner Blvd	22	EB	0	50	1440	30	0	
Bruckner Blvd	22	WB	0	40	480	65	0	
St. Ann's Ave	22	NB	0	25	105	30	0	
St. Ann's Ave	22	SB	0	55	70	25	0	2415

CBD Tolling
AS - Traffic Flowmap
AM Existing



- Legend:**
- ① - Intersection (2019 Collected Data)
 - ⑦ - Intersection (Uncollected Data)
 - 100 - ATR Volume
 - 100 - Approach Volume

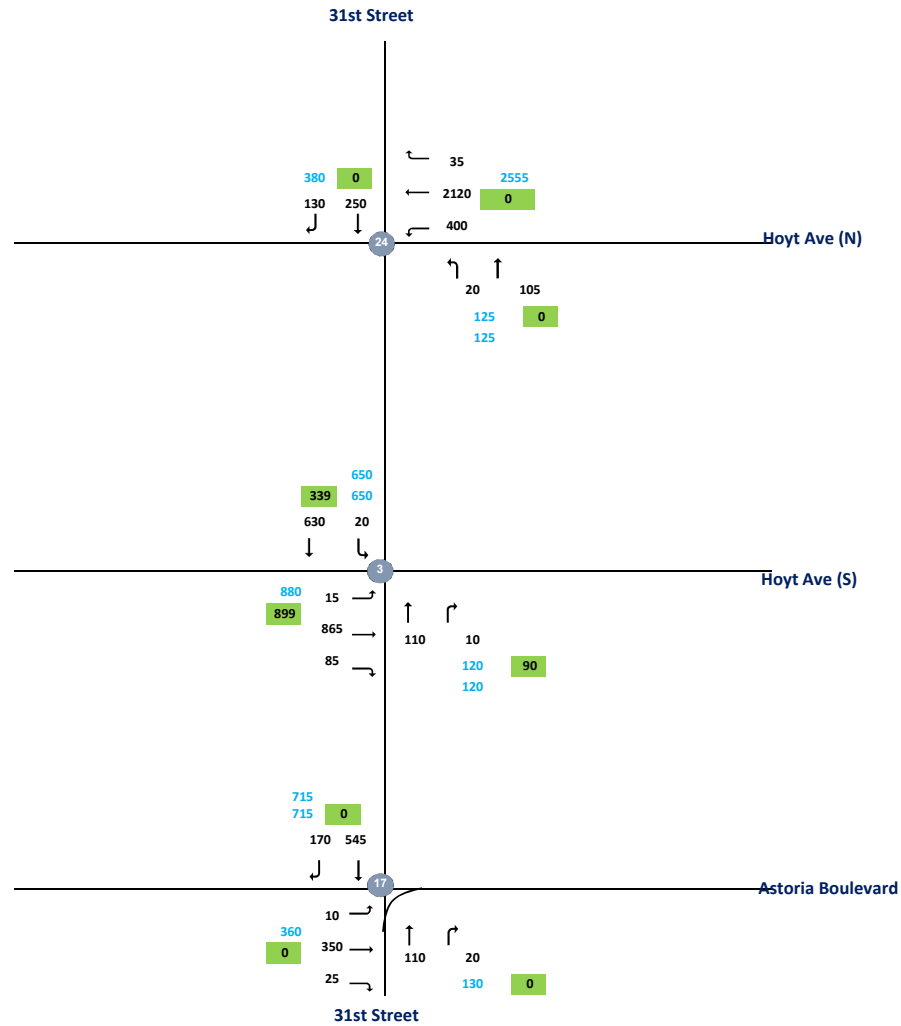

AS

7:15:00 AM

Intersection	Node	Approach	Total Vehicles						
			Inbound/Outbound						
			AM Peak Hour						
			L2	L	T	R	R2	Total	
31st Street and Astoria Blvd 2019 (TMC-062)	17								
Astoria Blvd	17	EB	0	10	350	25	0		
Astoria Blvd	17	WB	0	0	0	0	0		
31st Street	17	NB	0	0	110	20	0		
31st Street	17	SB	0	0	545	170	0		1230
31st Street and Hoyt Ave N 2019 (TMC-063)	24								
Hoyt Ave N	24	EB	0	0	0	0	0		
Hoyt Ave N	24	WB	0	400	2120	35	0		
31st Street	24	NB	0	20	105	0	0		
31st Street	24	SB	0	0	250	130	0		3060
31st Street and Hoyt Ave S 2019 (TMC-064)	3								
Hoyt Ave S	3	EB	0	15	865	85	0		
	3		0	0	0	0	0		
31st Street	3	NB	0	0	110	10	0		
31st Street	3	SB	0	20	630	0	0		1735

CBD Tolling
RKM - Traffic Flowmap
AM Existing



- Legend:**
- 1 - Intersection (2019 Collected Data)
 - 7 - Intersection (Uncollected Data)
 - 100 - ATR Volume
 - 100 - Approach Volume

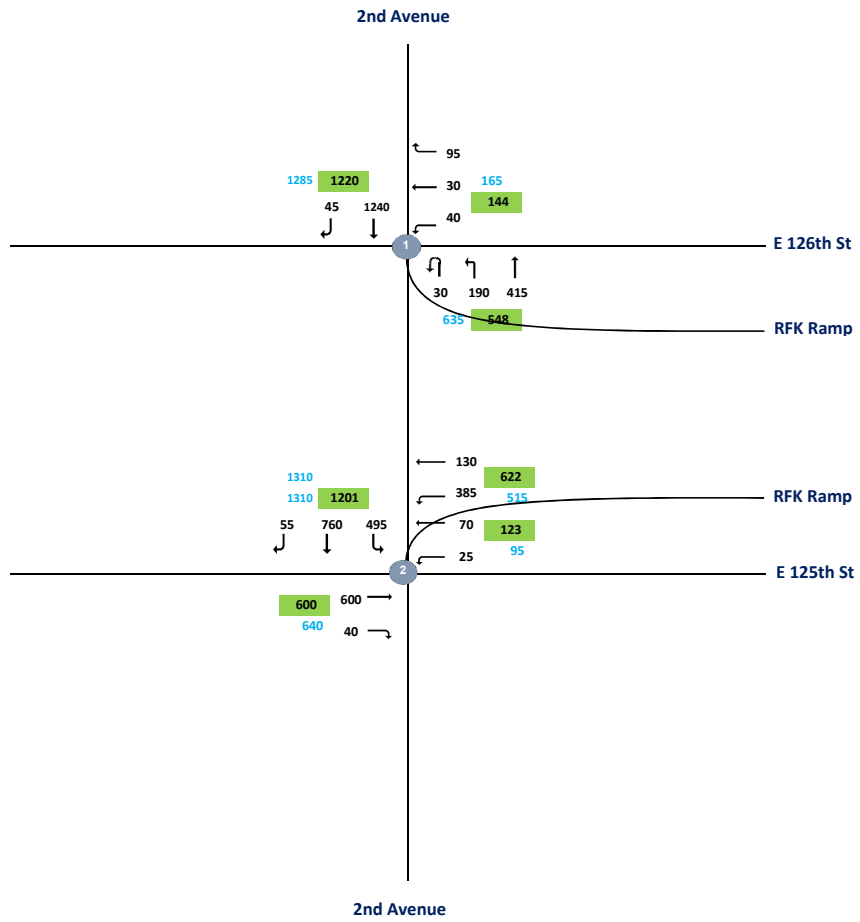

RKM

7:45 AM

Intersection	Node	Approach	Total Vehicles						Total
			Inbound/Outbound						
			AM Peak Hour						
			L2	L	T	R	R2		
E 126th Street and 2nd Ave 2019 (TMC-058)									
RFK Ramp	1	NW	30	190	0	415	0		
E 126th Street	1	EB	0	0	0	0	0		
E 126th Street	1	WB	0	40	30	95	0		
2nd Ave	1	NB	0	0	0	0	0		
2nd Ave	1	SB	0	0	1240	45	0	1450	
E 125th Street and 2nd Ave 2019 (TMC-059)									
E 125th Street	2	EB	0	0	600	40	0		
E 125th Street	2	WB	0	25	70	0	0		
2nd Ave	2	SW	0	385	0	130	0		
2nd Ave	2	SB	0	495	760	55	0	2560	

CBD Tolling
RKB - Traffic Flowmap
MD Existing



- Legend:**
- ① - Intersection (2019 Collected Data)
 - ⑦ - Intersection (Uncollected Data)
 - 100 - ATR Volume
 - 100 - Approach Volume

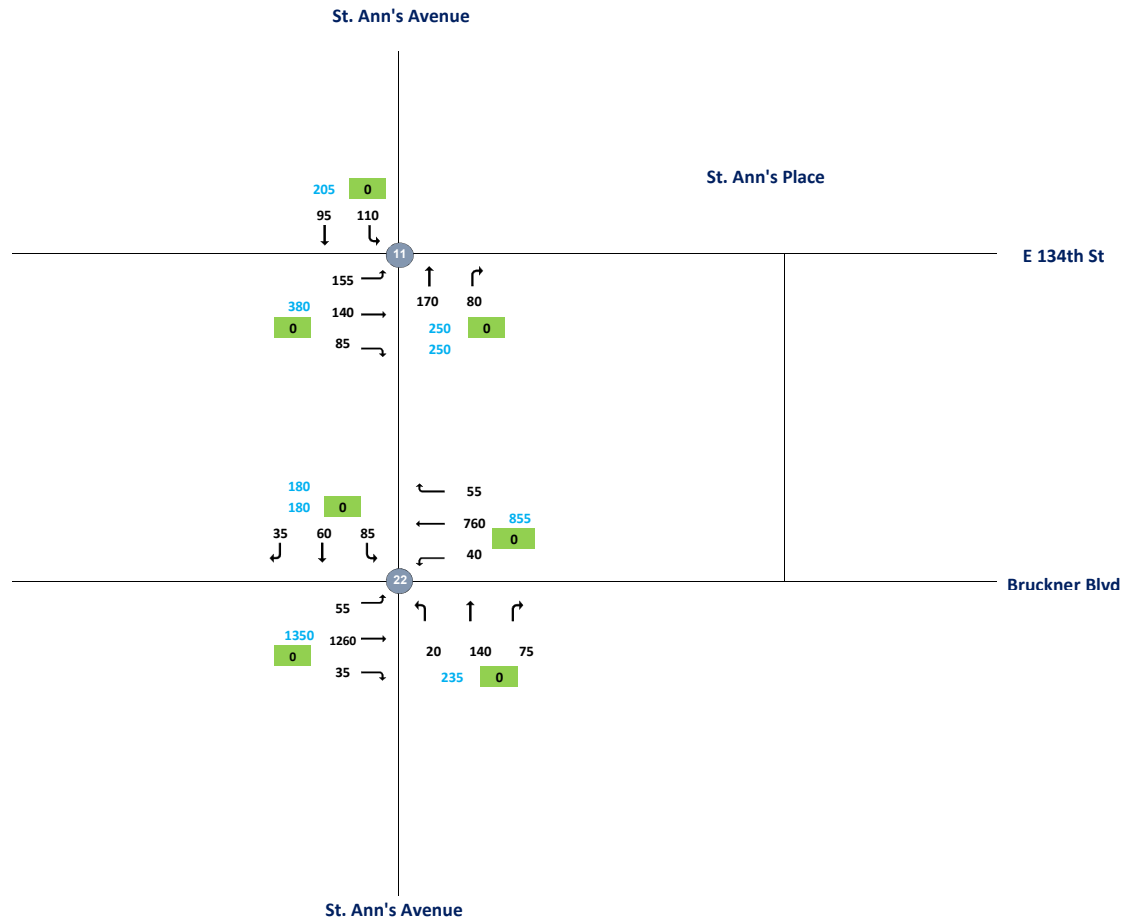

RKB

1:00 PM

Intersection	Node	Approach	Total Vehicles					
			Inbound/Outbound					Total
			MD Peak Hour					
L2	L	T	R	R2				
E 134th Street and St. Ann's Ave 2019 (TMC-060)	11							
E 134th Street	11	EB	0	155	140	85	0	
E 134th Street	11	WB	0	0	0	0	0	
St. Ann's Ave	11	NB	0	0	170	80	0	
St. Ann's Ave	11	SB	0	110	95	0	0	835
Bruckner Blvd and St. Ann's Ave 2019 (TMC-061)	22							
Bruckner Blvd	22	EB	0	55	1260	35	0	
Bruckner Blvd	22	WB	0	40	760	55	0	
St. Ann's Ave	22	NB	0	20	140	75	0	
St. Ann's Ave	22	SB	0	85	60	35	0	2620

CBD Tolling
AS - Traffic Flowmap
MD Existing



- Legend:**
- ① - Intersection (2019 Collected Data)
 - ⑦ - Intersection (Uncollected Data)
 - 100 - ATR Volume
 - 100 - Approach Volume

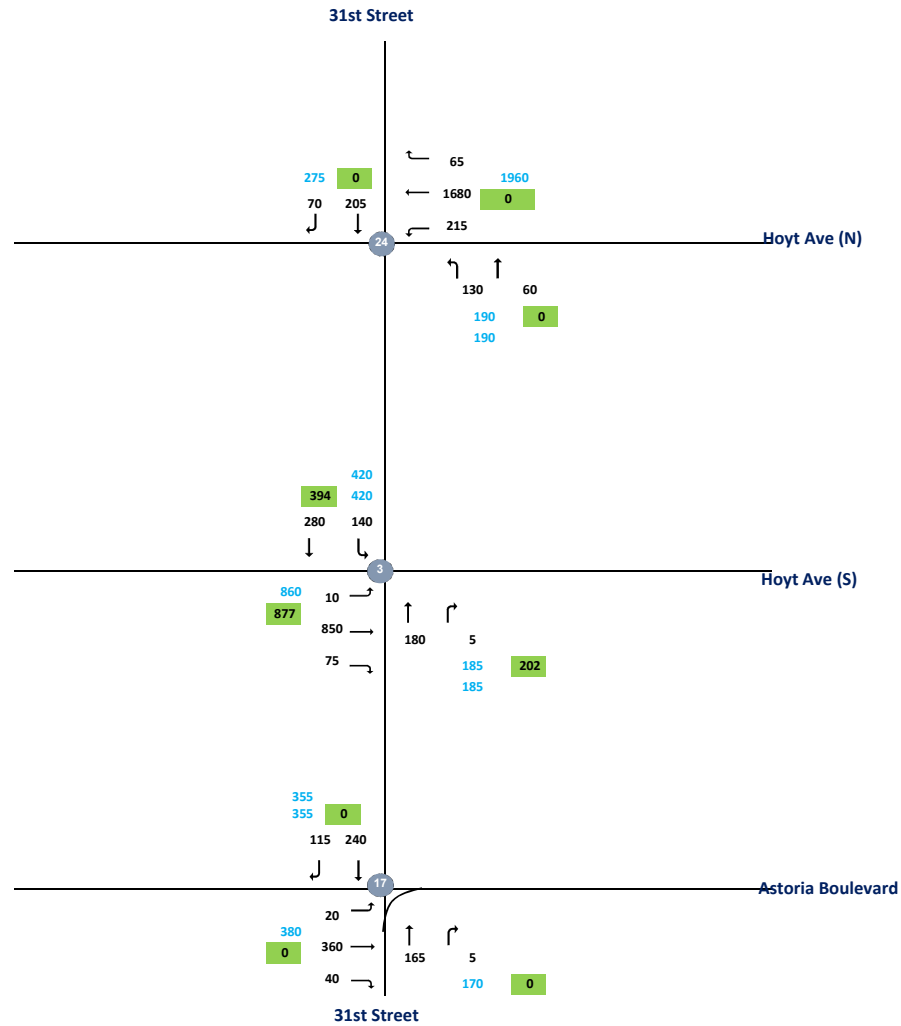

AS

12:30:00 PM

Intersection	Node	Approach	Total Vehicles						
			Inbound/Outbound						
			MD Peak Hour						
			L2	L	T	R	R2	Total	
31st Street and Astoria Blvd 2019 (TMC-062)	17								
Astoria Blvd	17	EB	0	20	360	40	0		
Astoria Blvd	17	WB	0	0	0	0	0		
31st Street	17	NB	0	0	165	5	0		
31st Street	17	SB	0	0	240	115	0		945
31st Street and Hoyt Ave N 2019 (TMC-063)	24								
Hoyt Ave N	24	EB	0	0	0	0	0		
Hoyt Ave N	24	WB	0	215	1680	65	0		
31st Street	24	NB	0	130	60	0	0		
31st Street	24	SB	0	0	205	70	0		2425
31st Street and Hoyt Ave S 2019 (TMC-064)	3								
Hoyt Ave S	3	EB	0	10	850	75	0		
	3		0	0	0	0	0		
31st Street	3	NB	0	0	180	5	0		
31st Street	3	SB	0	140	280	0	0		1540

CBD Tolling
RKM - Traffic Flowmap
MD Existing



- Legend:**
- 1 - Intersection (2019 Collected Data)
 - 7 - Intersection (Uncollected Data)
 - 100 - ATR Volume
 - 100 - Approach Volume

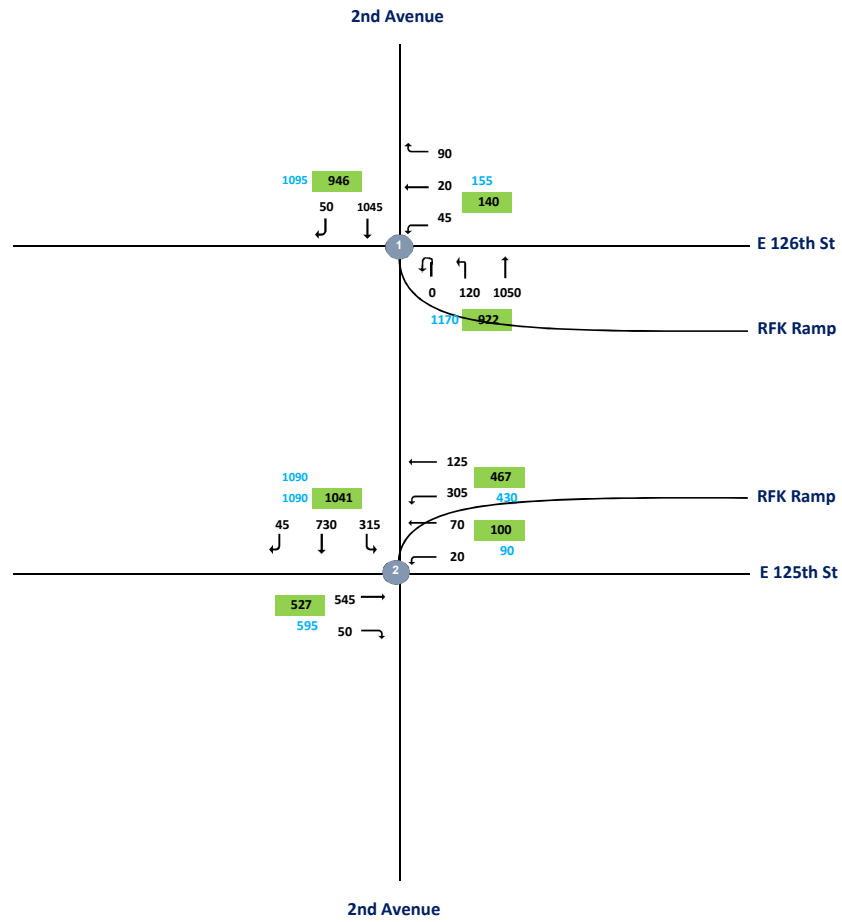

RKM

1:00 PM

Intersection	Node	Approach	Total Vehicles						
			Inbound/Outbound					Total	
			L2	L	T	R	R2		
E 126th Street and 2nd Ave 2019 (TMC-058) RFK Ramp	1	NW	0	120	0	1050	0		
E 126th Street	1	EB	0	0	0	0	0		
E 126th Street	1	WB	0	45	20	90	0		
2nd Ave	1	NB	0	0	0	0	0		
2nd Ave	1	SB	0	0	1045	50	0	1250	
E 125th Street and 2nd Ave 2019 (TMC-059)	2								
E 125th Street	2	EB	0	0	545	50	0		
E 125th Street	2	WB	0	20	70	0	0		
2nd Ave	2	SW	0	305	0	125	0		
2nd Ave	2	SB	0	315	730	45	0	2205	

CBD Tolling
RKB - Traffic Flowmap
PM Existing



- Legend:**
- ① - Intersection (2019 Collected Data)
 - ⑦ - Intersection (Uncollected Data)
 - 100 - ATR Volume
 - 100 - Approach Volume

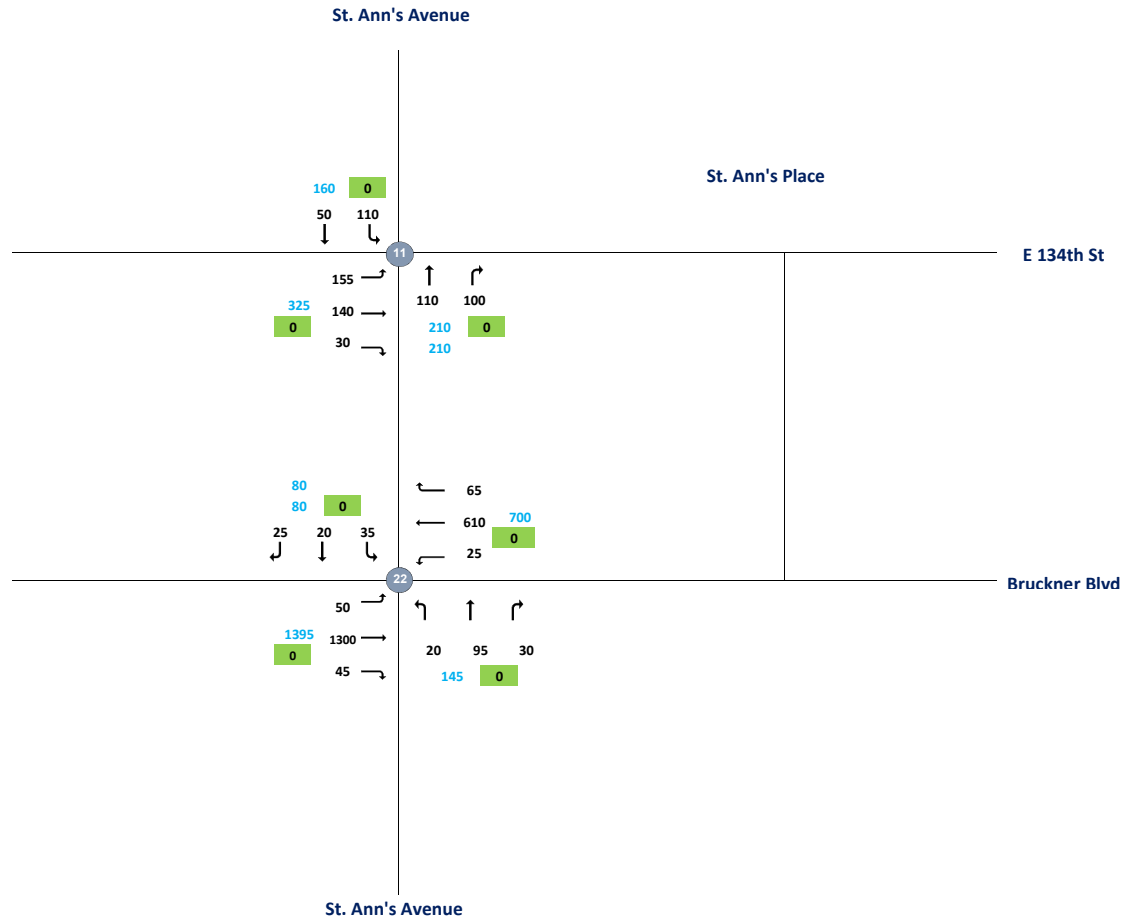

RKB

5:00 PM

Intersection	Node	Approach	Total Vehicles					
			Inbound/Outbound					Total
			PM Peak Hour					
L2	L	T	R	R2				
E 134th Street and St. Ann's Ave 2019 (TMC-060)	11							
E 134th Street	11	EB	0	155	140	30	0	
E 134th Street	11	WB	0	0	0	0	0	
St. Ann's Ave	11	NB	0	0	110	100	0	
St. Ann's Ave	11	SB	0	110	50	0	0	695
Bruckner Blvd and St. Ann's Ave 2019 (TMC-061)	22							
Bruckner Blvd	22	EB	0	50	1300	45	0	
Bruckner Blvd	22	WB	0	25	610	65	0	
St. Ann's Ave	22	NB	0	20	95	30	0	
St. Ann's Ave	22	SB	0	35	20	25	0	2320

CBD Tolling
AS - Traffic Flowmap
PM Existing



- Legend:**
- ① - Intersection (2019 Collected Data)
 - ⑦ - Intersection (Uncollected Data)
 - 100 - ATR Volume
 - 100 - Approach Volume

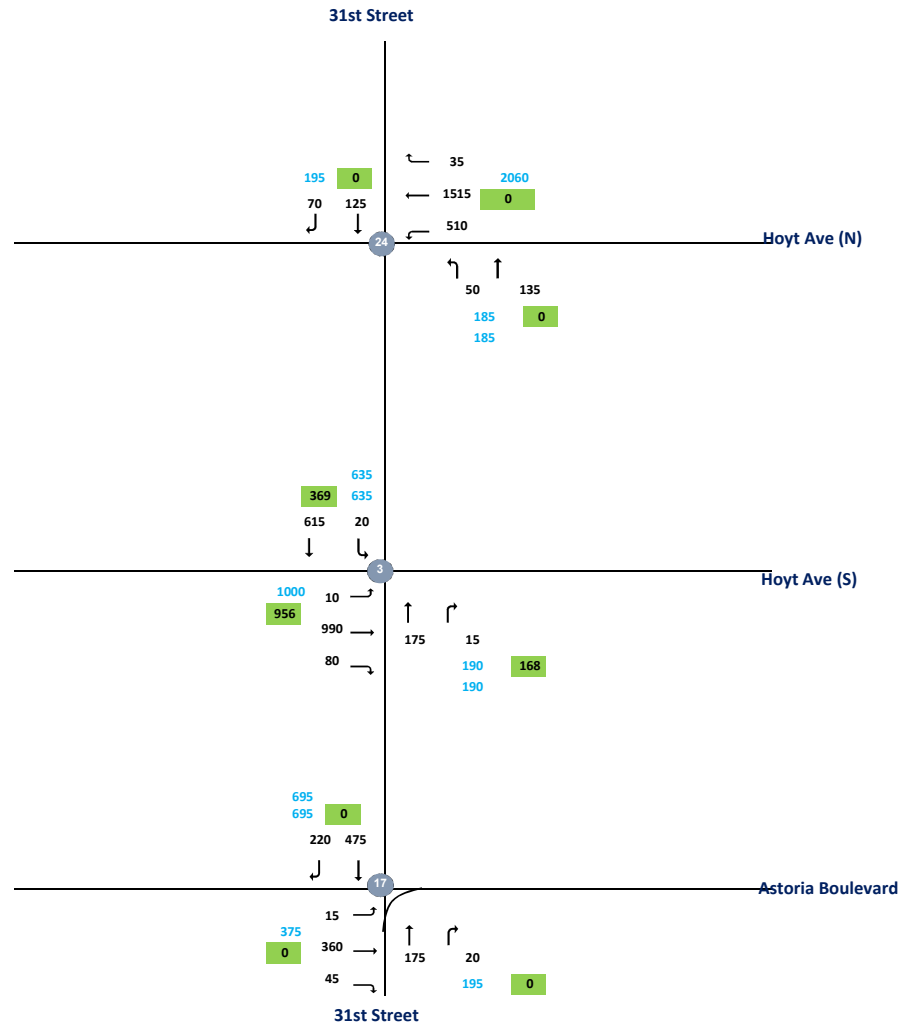

AS

4:00:00 PM

Intersection	Node	Approach	Total Vehicles						
			Inbound/Outbound						
			PM Peak Hour						
			L2	L	T	R	R2	Total	
31st Street and Astoria Blvd 2019 (TMC-062)	17								
Astoria Blvd	17	EB	0	15	360	45	0		
Astoria Blvd	17	WB	0	0	0	0	0		
31st Street	17	NB	0	0	175	20	0		
31st Street	17	SB	0	0	475	220	0		1310
31st Street and Hoyt Ave N 2019 (TMC-063)	24								
Hoyt Ave N	24	EB	0	0	0	0	0		
Hoyt Ave N	24	WB	0	510	1515	35	0		
31st Street	24	NB	0	50	135	0	0		
31st Street	24	SB	0	0	125	70	0		2440
31st Street and Hoyt Ave S 2019 (TMC-064)	3								
Hoyt Ave S	3	EB	0	10	990	80	0		
	3		0	0	0	0	0		
31st Street	3	NB	0	0	175	15	0		
31st Street	3	SB	0	20	615	0	0		1905

CBD Tolling
RKM - Traffic Flowmap
PM Existing



- Legend:**
- 1 - Intersection (2019 Collected Data)
 - 7 - Intersection (Uncollected Data)
 - 100 - ATR Volume
 - 100 - Approach Volume

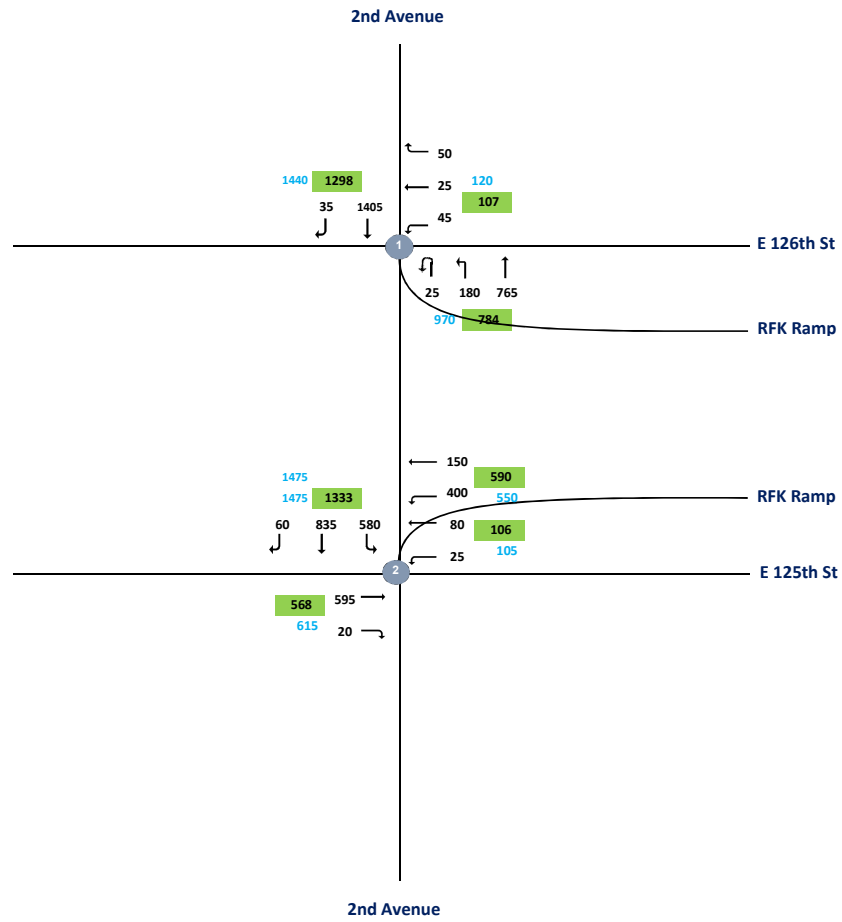

RKM

4:00 PM

Intersection	Node	Approach	Total Vehicles						
			Inbound/Outbound					Total	
			L2	L	T	R	R2		
E 126th Street and 2nd Ave 2019 (TMC-058) RFK Ramp	1	NW	25	180	0	765	0		
E 126th Street	1	EB	0	0	0	0	0		
E 126th Street	1	WB	0	45	25	50	0		
2nd Ave	1	NB	0	0	0	0	0		
2nd Ave	1	SB	0	0	1405	35	0	1560	
E 125th Street and 2nd Ave 2019 (TMC-059)	2								
E 125th Street	2	EB	0	0	595	20	0		
E 125th Street	2	WB	0	25	80	0	0		
2nd Ave	2	SW	0	400	0	150	0		
2nd Ave	2	SB	0	580	835	60	0	2745	

CBD Tolling
RKB - Traffic Flowmap
LN Existing



- Legend:**
- ① - Intersection (2019 Collected Data)
 - ⑦ - Intersection (Uncollected Data)
 - 100 - ATR Volume
 - 100 - Approach Volume

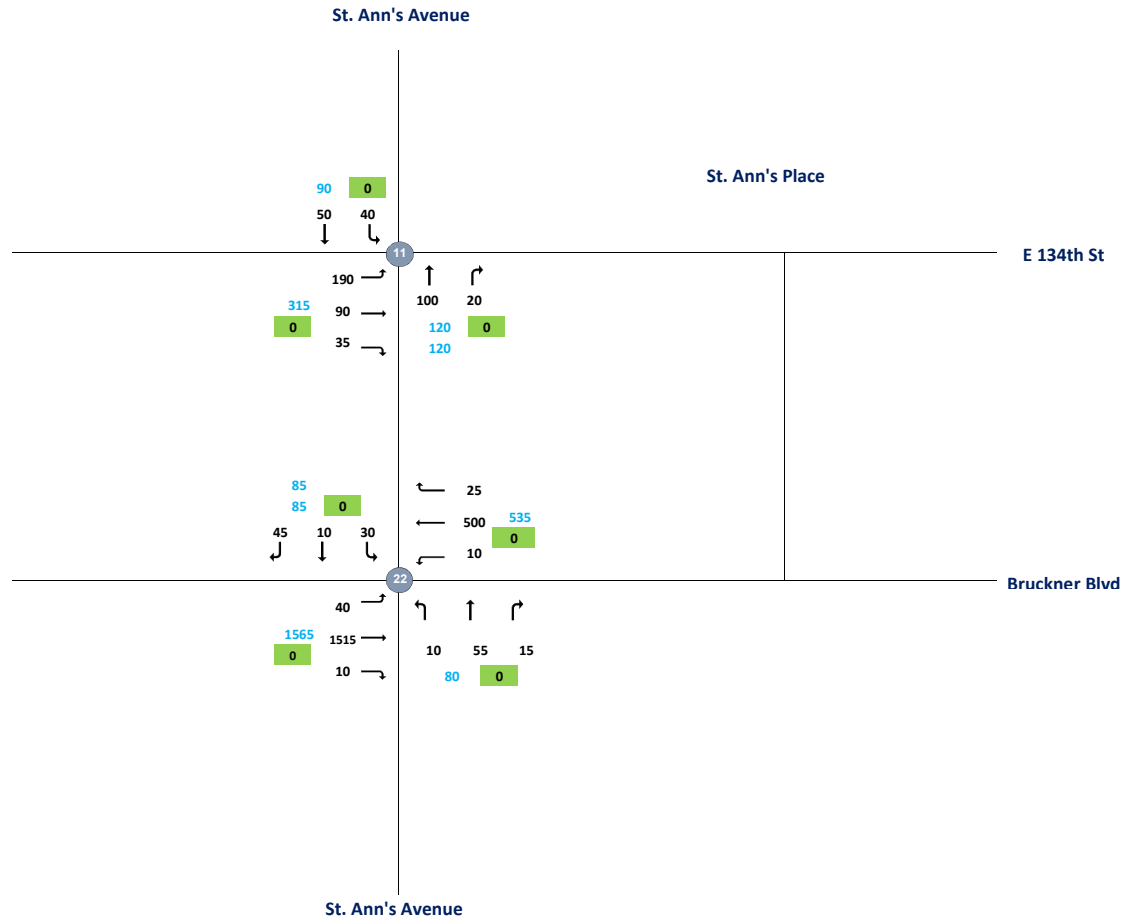

RKB

9:00 PM

Intersection	Node	Approach	Total Vehicles						
			Inbound/Outbound						
			LN Peak Hour						
			L2	L	T	R	R2	Total	
E 134th Street and St. Ann's Ave 2019 (TMC-060)	11								
E 134th Street	11	EB	0	190	90	35	0		
E 134th Street	11	WB	0	0	0	0	0		
St. Ann's Ave	11	NB	0	0	100	20	0		
St. Ann's Ave	11	SB	0	40	50	0	0		525
Bruckner Blvd and St. Ann's Ave 2019 (TMC-061)	22								
Bruckner Blvd	22	EB	0	40	1515	10	0		
Bruckner Blvd	22	WB	0	10	500	25	0		
St. Ann's Ave	22	NB	0	10	55	15	0		
St. Ann's Ave	22	SB	0	30	10	45	0		2265

CBD Tolling
AS - Traffic Flowmap
LN Existing



- Legend:**
- ① - Intersection (2019 Collected Data)
 - ⑦ - Intersection (Uncollected Data)
 - 100 - ATR Volume
 - 100 - Approach Volume

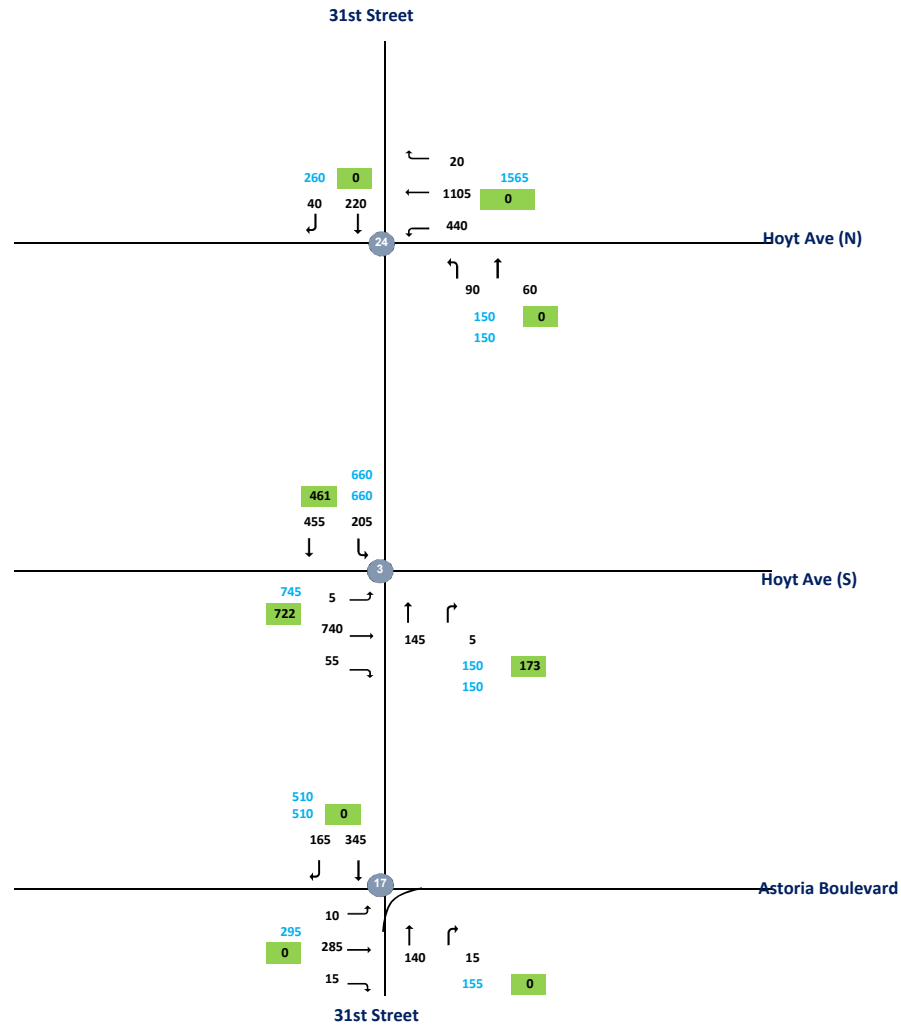

AS

9:45:00 PM

Intersection	Node	Approach	Total Vehicles					
			Inbound/Outbound					
			LN Peak Hour					
			L2	L	T	R	R2	Total
31st Street and Astoria Blvd 2019 (TMC-062)	17							
Astoria Blvd	17	EB	0	10	285	15	0	
Astoria Blvd	17	WB	0	0	0	0	0	
31st Street	17	NB	0	0	140	15	0	
31st Street	17	SB	0	0	345	165	0	975
31st Street and Hoyt Ave N 2019 (TMC-063)	24							
Hoyt Ave N	24	EB	0	0	0	0	0	
Hoyt Ave N	24	WB	0	440	1105	20	0	
31st Street	24	NB	0	90	60	0	0	
31st Street	24	SB	0	0	220	40	0	1975
31st Street and Hoyt Ave S 2019 (TMC-064)	3							
Hoyt Ave S	3	EB	0	5	740	55	0	
	3		0	0	0	0	0	
31st Street	3	NB	0	0	145	5	0	
31st Street	3	SB	0	205	455	0	0	1610

CBD Tolling
RKM - Traffic Flowmap
LN Existing



- Legend:**
- 1 - Intersection (2019 Collected Data)
 - 7 - Intersection (Uncollected Data)
 - 100 - ATR Volume
 - 100 - Approach Volume

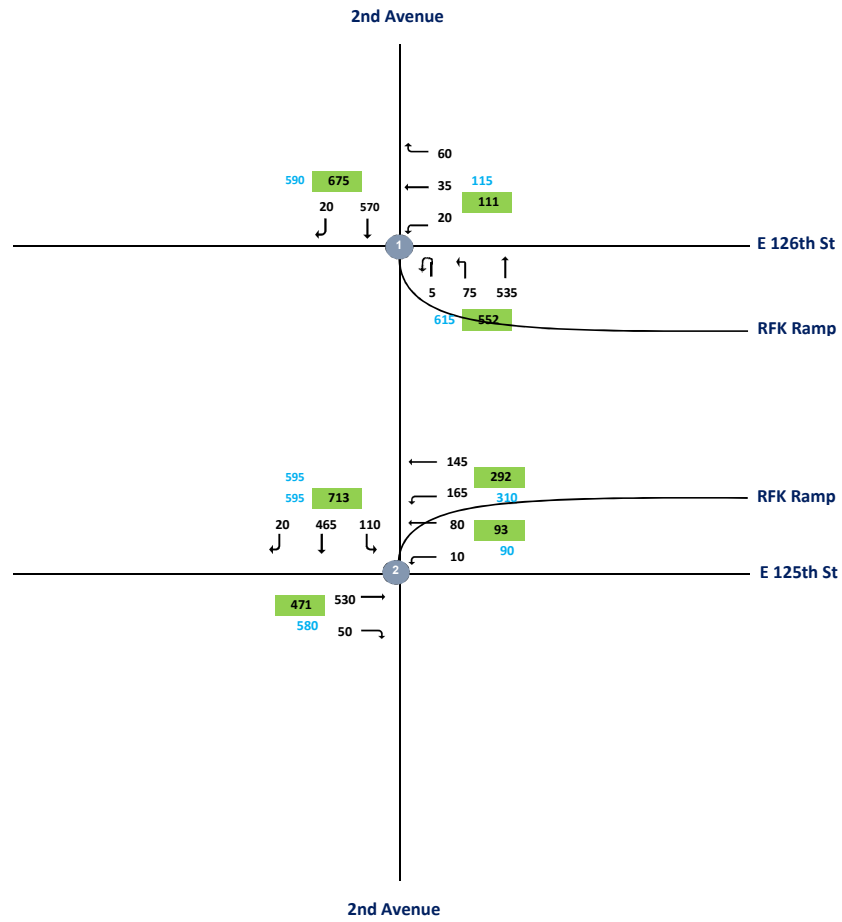

CBD Tolling
Red Hook- Traffic Flowmap
AM Existing



- Legend:**
- ① - Intersection (2019 Collected Data)
 - ⑦ - Intersection (Uncollected Data)
 - 100 - ATR Volume
 - 100 - Approach Volume

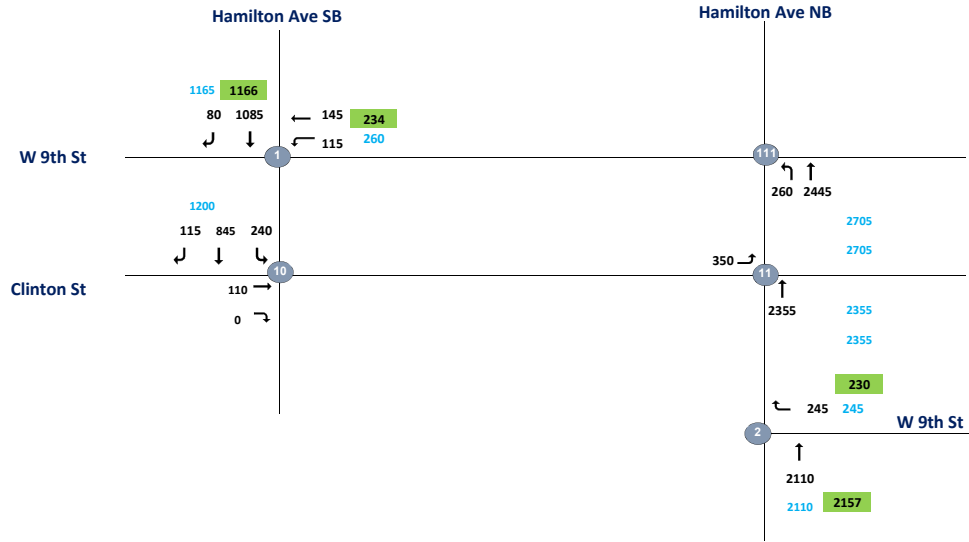

RH

7:45:00 AM

Intersection	Node	Approach	Total Vehicles					Total
			Inbound/Outbound					
			AM Peak Hour					
			L2	L	T	R	R2	
Hamilton Ave SB & W 9th St 2019 (TMC-040)	1							
W 9th St	1	EB	0	0	0	0	0	
W 9th St	1	WB	0	115	145	0	0	
-	1		0	0	0	0	0	
Hamilton Ave SB	1	SB	0	0	1085	80	0	1425
Hamilton Ave SB & Clinton St 2019 (TMC-040)	10							
Clinton St	10	EB			110	0		
Clinton St	10	WB						
-	10							
Hamilton Ave SB	10	SB	240	845	115			1310
Hamilton Ave NB & Clinton St EB 2019 (TMC-040)	11							
Clinton St	11	EB	350					
-	11							
Hamilton Ave	11	NB		2355				
-	11							2705
Hamilton Ave NB & W 9th St WB 2019 (TMC-040)	111							
W 9th St	111	EB	0	0	0	0	0	
-	111	WB	0	0	0	0	0	
Hamilton Ave	111	NB	0	260	2445	0	0	
-	111	SB	0	0	0	0	0	2705
Hamilton Ave NB & W 9th St 2019 (TMC-041)	2							
-	2	EB	0	0	0	0	0	
W 9th St	2	WB	0	0	0	245	0	
Hamilton Ave	2	NB	0	0	2110	0	0	
-	2	SB	0	0	0	0	0	2355

CBD Tolling
Red Hook- Traffic Flowmap
MD Existing



- Legend:**
- ① - Intersection (2019 Collected Data)
 - ⑦ - Intersection (Uncollected Data)
 - 100 - ATR Volume
 - .100 - Approach Volume

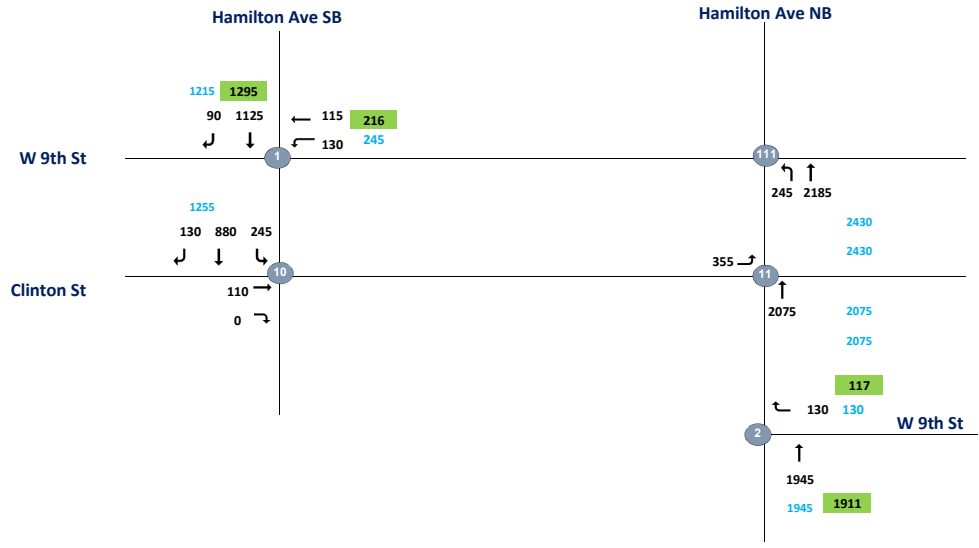

RH

12:00:00 PM

Intersection	Node	Approach	Total Vehicles					Total
			Inbound/Outbound					
			MD Peak Hour					
			L2	L	T	R	R2	
Hamilton Ave SB & W 9th St 2019 (TMC-040)	1							
W 9th St	1	EB	0	0	0	0	0	
W 9th St	1	WB	0	130	115	0	0	
Hamilton Ave SB	1		0	0	0	0	0	
Hamilton Ave SB	1	SB	0	0	1125	90	0	1460
Hamilton Ave SB & W 9th St 2019 (TMC-040)	10							
Clinton Avenue	10	EB			110	0		
Clinton Avenue	10	WB						
Hamilton Ave SB	10							
Hamilton Ave SB	10	SB	245	880	130			1365
Hamilton Ave SB & W 9th St 2019 (TMC-040)	11							
Clinton Avenue	11	EB	355					
Clinton Avenue	11							
Hamilton Ave	11	NB			2075			
Hamilton Ave	11							2430
Hamilton Ave SB & W 9th St 2019 (TMC-040)	111							
W 9th St	111	EB	0	0	0	0	0	
W 9th St	111	WB	0	0	0	0	0	
Hamilton Ave	111	NB	0	245	2185	0	0	
-	111	SB	0	0	0	0	0	2430
Hamilton Ave NB & W 9th St 2019 (TMC-041)	2							
W 9th St	2	EB	0	0	0	0	0	
W 9th St	2	WB	0	0	0	130	0	
Hamilton Ave	2	NB	0	0	1945	0	0	
Hamilton Ave	2	SB	0	0	0	0	0	2075

CBD Tolling
Red Hook- Traffic Flowmap
PM Existing



- Legend:**
- ① - Intersection (2019 Collected Data)
 - ⑦ - Intersection (Uncollected Data)
 - 100 - ATR Volume
 - .100 - Approach Volume

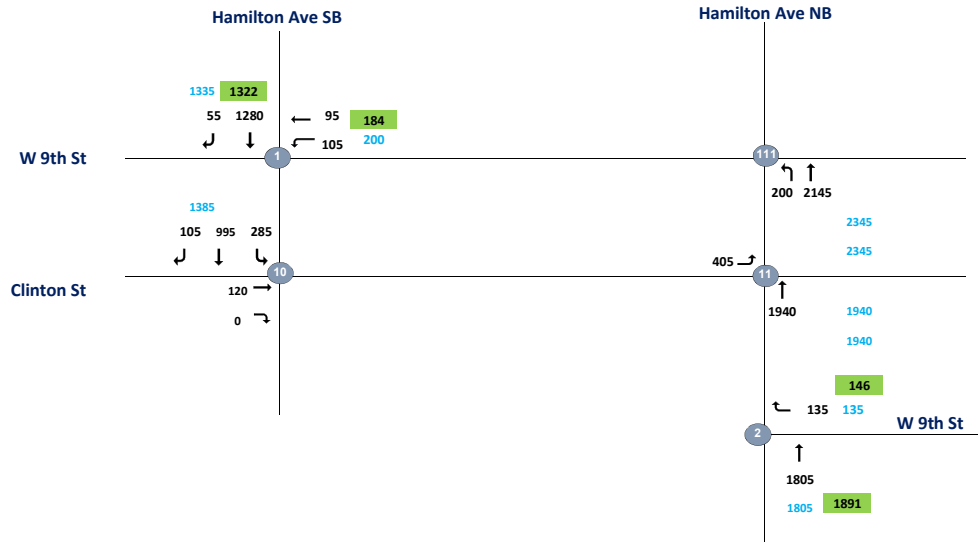

RH

4:00:00 PM

Intersection	Node	Approach	Total Vehicles					Total
			Inbound/Outbound					
			PM Peak Hour					
			L2	L	T	R	R2	
Hamilton Ave SB & W 9th St 2019 (TMC-040)	1							
W 9th St	1	EB	0	0	0	0	0	
W 9th St	1	WB	0	105	95	0	0	
Hamilton Ave SB	1		0	0	0	0	0	
Hamilton Ave SB	1	SB	0	0	1280	55	0	1535
Hamilton Ave SB & W 9th St 2019 (TMC-040)	10							
Clinton Avenue	10	EB			120	0		
Clinton Avenue	10	WB						
Hamilton Ave SB	10							
Hamilton Ave SB	10	SB	285	995	105			1505
Hamilton Ave SB & W 9th St 2019 (TMC-040)	11							
Clinton Avenue	11	EB	405					
Clinton Avenue	11							
Hamilton Ave	11	NB			1940			
Hamilton Ave	11							2345
Hamilton Ave SB & W 9th St 2019 (TMC-040)	111							
W 9th St	111	EB	0	0	0	0	0	
W 9th St	111	WB	0	0	0	0	0	
Hamilton Ave	111	NB	0	200	2145	0	0	
-	111	SB	0	0	0	0	0	2345
Hamilton Ave NB & W 9th St 2019 (TMC-041)	2							
W 9th St	2	EB	0	0	0	0	0	
W 9th St	2	WB	0	0	0	135	0	
Hamilton Ave	2	NB	0	0	1805	0	0	
Hamilton Ave	2	SB	0	0	0	0	0	1940

CBD Tolling
Red Hook- Traffic Flowmap
LN Existing



- Legend:**
- ① - Intersection (2019 Collected Data)
 - ⑦ - Intersection (Uncollected Data)
 - 100 - ATR Volume
 - .100 - Approach Volume

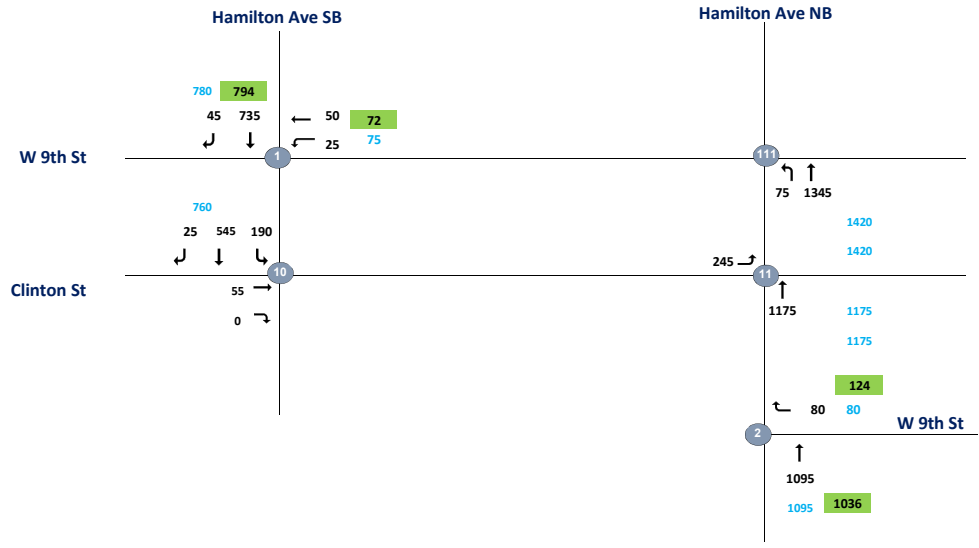

RH

9:00:00 PM

Intersection	Node	Approach	Total Vehicles					Total
			Inbound/Outbound					
			LN Peak Hour					
			L2	L	T	R	R2	
Hamilton Ave SB & W 9th St 2019 (TMC-040)	1							
W 9th St	1	EB	0	0	0	0	0	
W 9th St	1	WB	0	25	50	0	0	
Hamilton Ave SB	1		0	0	0	0	0	
Hamilton Ave SB	1	SB	0	0	735	45	0	855
Hamilton Ave SB & W 9th St 2019 (TMC-040)	10							
Clinton Avenue	10	EB			55	0		
Clinton Avenue	10	WB						
Hamilton Ave SB	10							
Hamilton Ave SB	10	SB	190	545	25			815
Hamilton Ave SB & W 9th St 2019 (TMC-040)	11							
Clinton Avenue	11	EB	245					
Clinton Avenue	11							
Hamilton Ave	11	NB			1175			
Hamilton Ave	11							1420
Hamilton Ave SB & W 9th St 2019 (TMC-040)	111							
W 9th St	111	EB	0	0	0	0	0	
W 9th St	111	WB	0	0	0	0	0	
Hamilton Ave	111	NB	0	75	1345	0	0	
-	111	SB	0	0	0	0	0	1420
Hamilton Ave NB & W 9th St 2019 (TMC-041)	2							
W 9th St	2	EB	0	0	0	0	0	
W 9th St	2	WB	0	0	0	80	0	
Hamilton Ave	2	NB	0	0	1095	0	0	
Hamilton Ave	2	SB	0	0	0	0	0	1175

CBD Tolling
UE #1 - Traffic Flowmap
AM Existing



- Legend:**
- 1 - Intersection (2019 Collected Data)
 - 7 - Intersection (Uncollected Data)
 - 100 - ATR Volume
 - 100 - Approach Volume

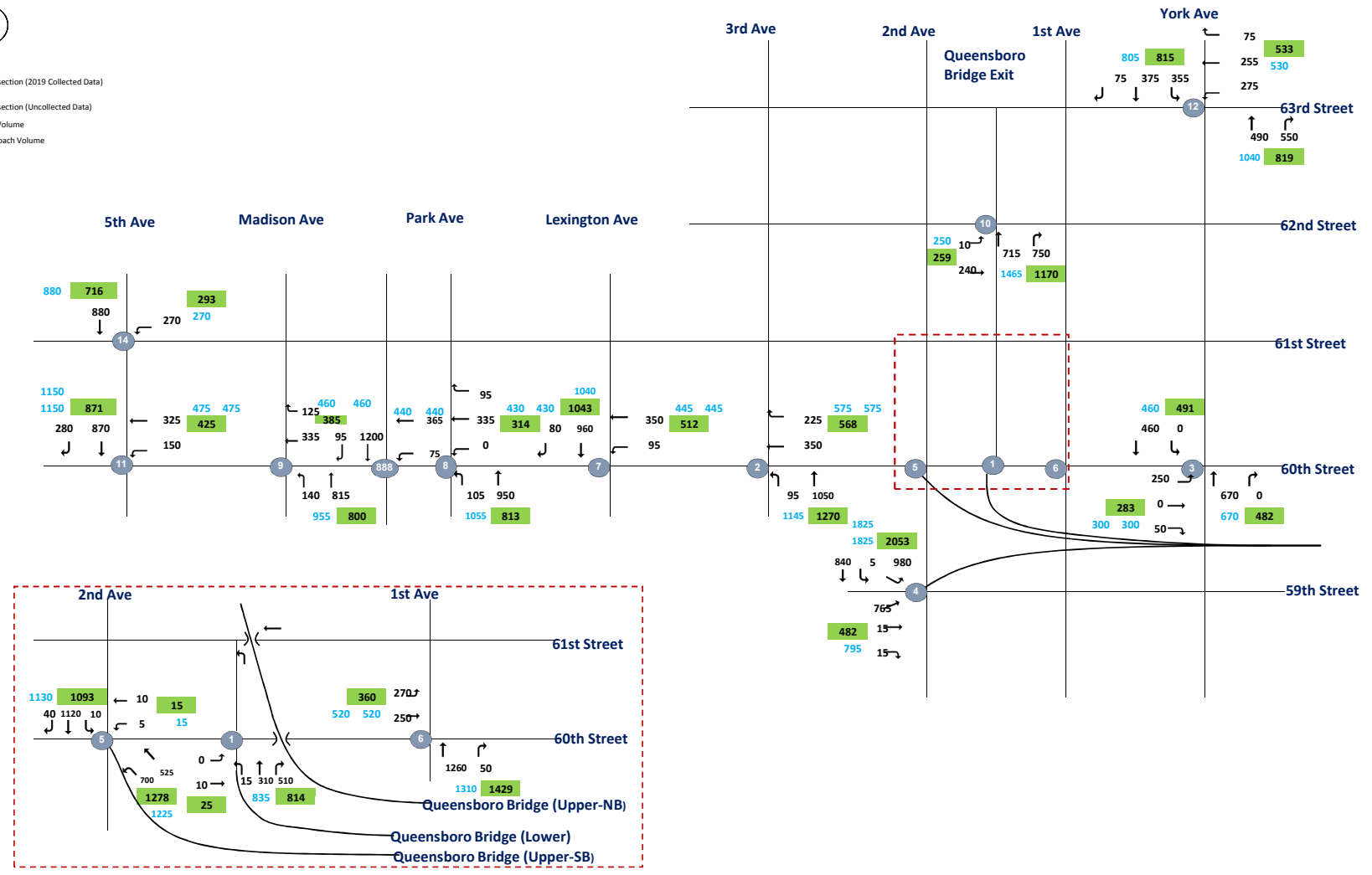

CBD Tolling
UE #2 - Traffic Flowmap
AM Existing



- Legend:**
- 1 - Intersection (2019 Collected Data)
 - 7 - Intersection (Uncollected Data)
 - 100 - ATR Volume
 - 100 - Approach Volume

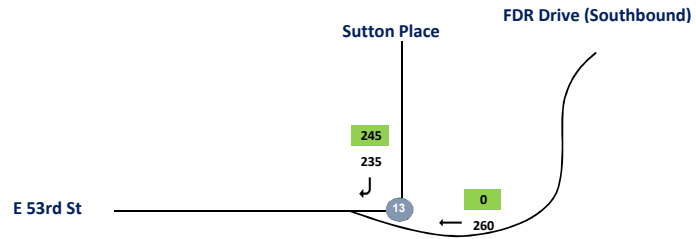

CBD Tolling
UE #3 - Traffic Flowmap
AM Existing



- Legend:**
- 1 - Intersection (2019 Collected Data)
 - 7 - Intersection (Uncollected Data)
 - 100 - ATR Volume
 - 100 - Approach Volume

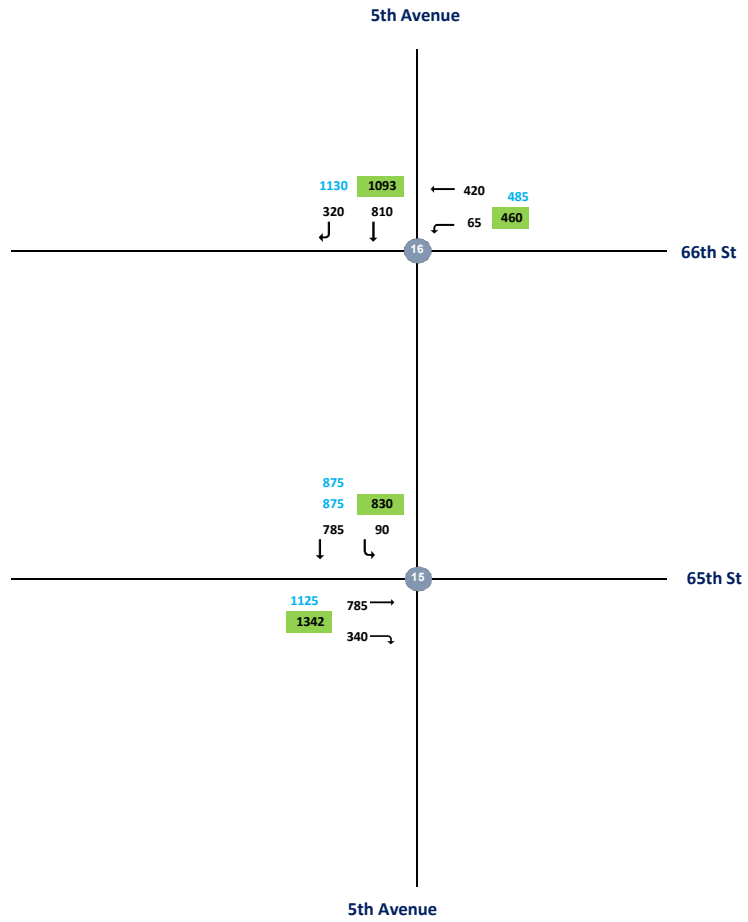

CBD Tolling
UE #3 - Traffic Flowmap
AM Existing



- Legend:**
- ① - Intersection (2019 Collected Data)
 - ⑦ - Intersection (Uncollected Data)
 - 100 - ATR Volume
 - 100 - Approach Volume

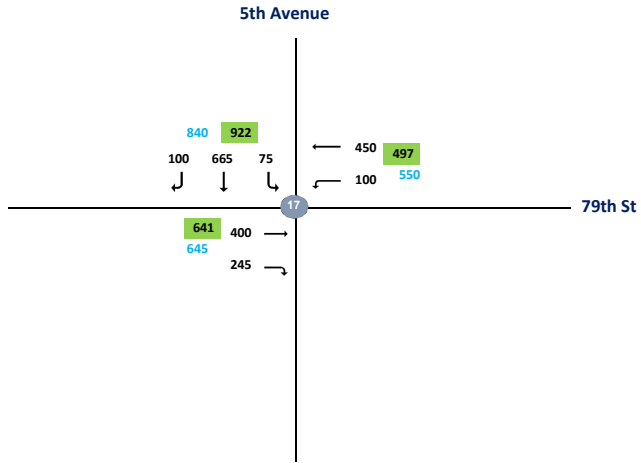

CBD Tolling
UE #4 - Traffic Flowmap
AM Existing



- Legend:**
- 1 - Intersection (2019 Collected Data)
 - 7 - Intersection (Uncollected Data)
 - 100 - ATR Volume
 - 100 - Approach Volume

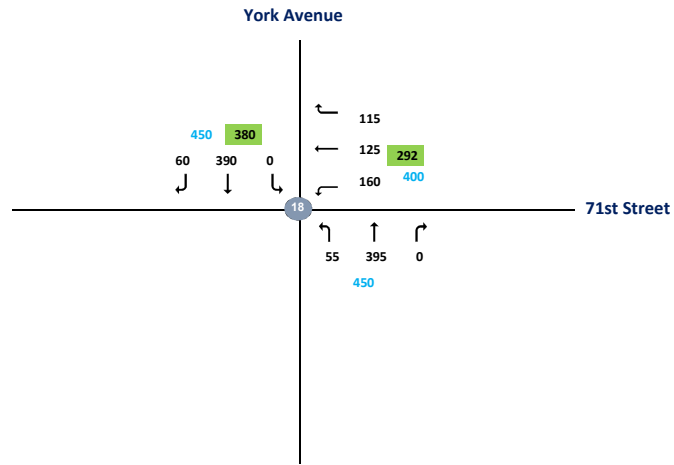

UE

8:00:00 AM

Intersection	Node	Approach	Total Vehicles					
			Inbound/Outbound					Total
			AM Peak Hour					
L2	L	T	R	R2				
60th Street & Queensboro Bridge Exit 2019 (TMC-022)	1							
60th Street	1	EB	0	0	10	0	0	
60th Street	1	WB	0	0	0	0	0	
Queensboro Bridge Exit	1	NB	0	15	310	510	0	
	1	SB	0	0	0	0	0	845
60th Street & 3rd Ave 2019 (TMC-023)	2							
60th Street	2	EB	0	0	0	0	0	
60th Street	2	WB	0	0	350	225	0	
3rd Ave	2	NB	0	95	1050	0	0	
	2	SB	0	0	0	0	0	1720
60th St & York Ave 2019 (TMC-024)	3							
60th St	3	EB	0	250	0	50	0	
60th St	3	WB	0	0	0	0	0	
York Ave	3	NB	0	0	670	0	0	
York Ave	3	SB	0	0	460	0	0	1430
59th St & 2nd Ave 2019 (TMC-025)	4							
Queensboro Bridge Exit (SWB)	4							
59th St	4	EB	0	0	765	15	15	
	4	WB	0	0	0	0	0	
	4	NB	0	0	0	0	0	
2nd Ave	4	SB	980	5	840	0	0	2620
60th Street & 2nd Ave 2019 (TMC-026)	5	WB(bridge)						
Queensboro Bridge Exit (NWB)	5	NW	700	525	0	0	0	
60th St	5	EB	0	0	0	0	0	
60th St	5	WB	0	5	10	0	0	
	5	NB	0	0	0	0	0	
2nd Ave	5	SB	10	0	1120	40	0	1185
60th St & 1st Ave 2019 (TMC-027)	6							
60th Ave	6	EB	0	270	250	0	0	
	6	WB	0	0	0	0	0	
1st Ave	6	NB	0	0	1260	50	0	
	6	SB	0	0	0	0	0	1830

60th St & Lexington Ave 2019 (TMC-028)	7							
	7	EB	0	0	0	0	0	
60th St	7	WB	0	95	350	0	0	
	7	NB	0	0	0	0	0	
Lexington Ave	7	SB	0	0	960	80	0	1485
60th St & Park Ave 2019 (TMC-029)	8							
	8	EB	0	0	0	0	0	
60th St	8	WB	0	0	335	95	0	
Park Ave	8	NB	0	105	950	0	0	
Park Ave	8	SB	0	0	0	0	0	1485
60th St & Park Ave 2019 (TMC-029)	888							
	888	EB	0	0	0	0	0	
60th St	888	WB	0	75	365	0	0	
Park Ave	888	NB	0	0	0	0	0	
Park Ave	888	SB	0	0	1200	95	0	1735
60th St & Madison Ave 2019 (TMC-030)	9							
	9	EB	0	0	0	0	0	
60th St	9	WB	0	0	335	125	0	
Madison Ave	9	NB	0	140	815	0	0	
	9	SB	0	0	0	0	0	1415
62nd St & Queensboror Bridge Exit 2019 (TMC-031)	10							
62nd St	10	EB	0	10	240	0	0	
	10	WB	0	0	0	0	0	
Queensboro Bridge Exit	10	NB	0	0	715	750	0	
	10	SB	0	0	0	0	0	1715
60th St & 5th Ave 2019 (TMC-032)	11							
	11	EB	0	0	0	0	0	
60th St	11	WB	0	150	325	0	0	
	11	NB	0	0	0	0	0	
5th Ave	11	SB	0	0	870	280	0	1625

63rd St & York Ave 2019 (TMC-033)	12							
	12	EB	0	0	0	0	0	
63rd St	12	WB	0	275	255	75	0	
York Ave	12	NB	0	0	490	550	0	
York Ave	12	SB	0	355	375	75	0	2450
53rd St & FDR Drive 2019 (TMC-034)	13							
	13	EB	0	0	0	0	0	
53rd St	13	SW	0	0	0	260	0	
	13	NB	0	0	0	0	0	
FDR Drive	13	SB	0	0	0	235	0	495
61st St & 5th Ave 2019 (TMC-035)	14							
	14	EB	0	0	0	0	0	
61st St	14	WB	0	270	0	0	0	
	14	NB	0	0	0	0	0	
5th Ave	14	SB	0	0	880	0	0	1150
65th St & 5th Ave 2019 (TMC-036)	15							
65th St	15	EB	0	0	785	340	0	
	15	WB	0	0	0	0	0	
	15	NB	0	0	0	0	0	
5th Ave	15	SB	0	90	785	0	0	2000
66th St & 5th Ave 2019 (TMC-037)	16							
	16	EB	0	0	0	0	0	
66th St	16	WB	0	65	420	0	0	
	16	NB	0	0	0	0	0	
5th Ave	16	SB	0	0	810	320	0	1615
79th St & 5th Ave 2019 (TMC-038)	17							
79th St	17	EB	0	0	400	245	0	
79th St	17	WB	0	100	450	0	0	
	17	NB	0	0	0	0	0	
5th Ave	17	SB	0	75	665	100	0	2035
71st St & York Ave 2019 (TMC-039)	18							
	18	EB	0	0	0	0	0	
71st St	18	WB	0	160	125	115	0	
York Ave	18	NB	0	55	395	0	0	
York Ave	18	SB	0	0	390	60	0	1300

CBD Tolling
UE #1 - Traffic Flowmap
MD Existing



- Legend:**
- 1 - Intersection (2019 Collected Data)
 - 7 - Intersection (Uncollected Data)
 - 100 - ATR Volume
 - 100 - Approach Volume

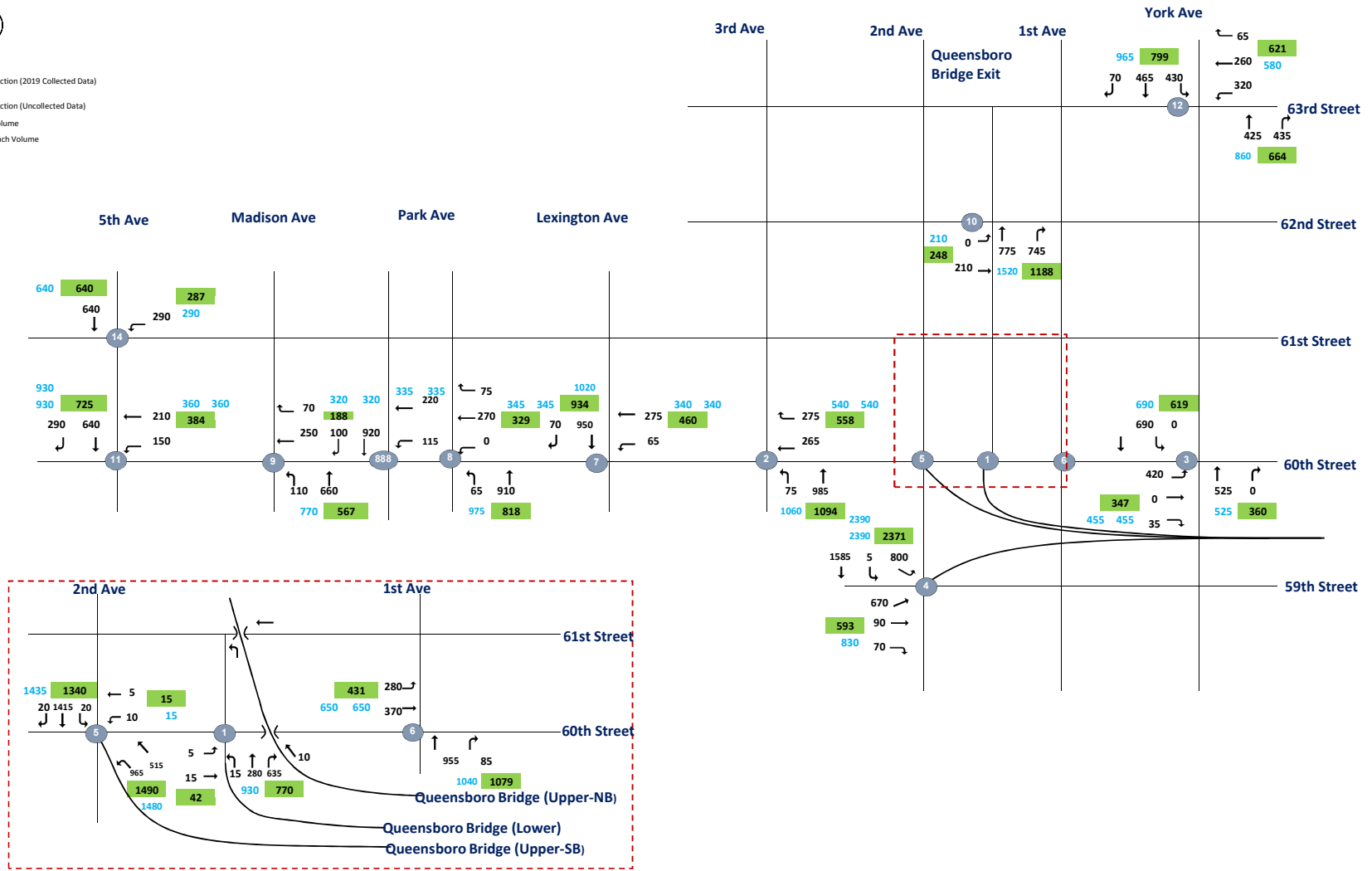

CBD Tolling
UE #2 - Traffic Flowmap
MD Existing



- Legend:**
- 1 - Intersection (2019 Collected Data)
 - 7 - Intersection (Uncollected Data)
 - 100 - ATR Volume
 - 100 - Approach Volume

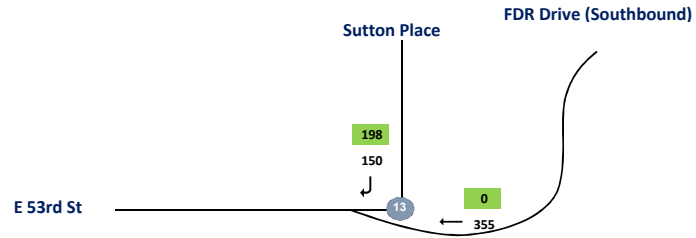

CBD Tolling
UE #3 - Traffic Flowmap
MD Existing



- Legend:**
- 1 - Intersection (2019 Collected Data)
 - 7 - Intersection (Uncollected Data)
 - 100 - ATR Volume
 - 100 - Approach Volume

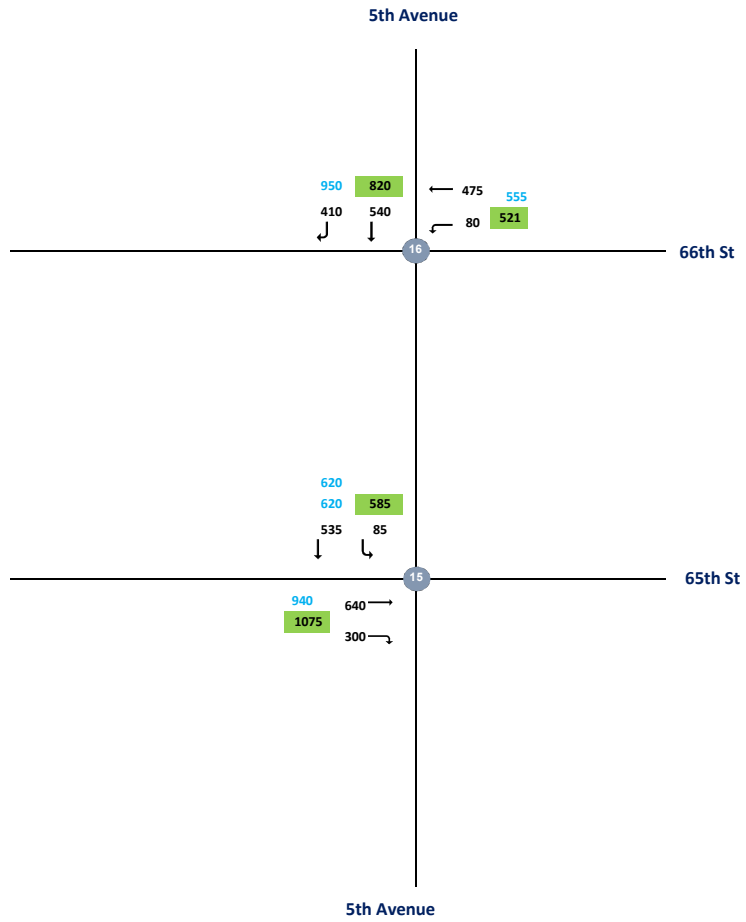

CBD Tolling
UE #3 - Traffic Flowmap
MD Existing



- Legend:**
- 1 - Intersection (2019 Collected Data)
 - 7 - Intersection (Uncollected Data)
 - 100 - ATR Volume
 - 100 - Approach Volume

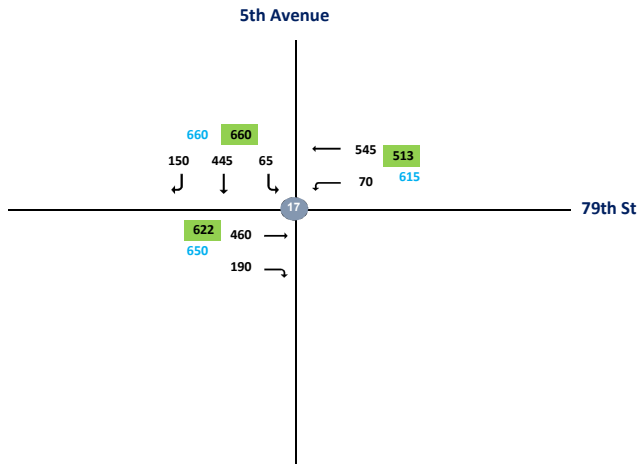

CBD Tolling
UE #4 - Traffic Flowmap
MD Existing



- Legend:**
- 1 - Intersection (2019 Collected Data)
 - 7 - Intersection (Uncollected Data)
 - 100 - ATR Volume
 - 100 - Approach Volume

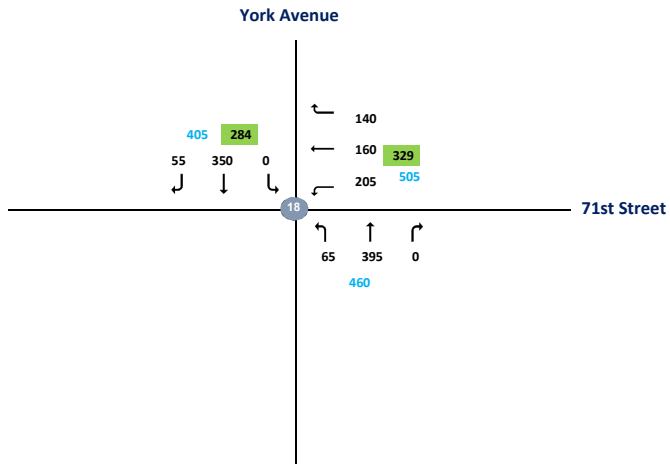

UE

1:00:00 PM

Intersection	Node	Approach	Total Vehicles					
			Inbound/Outbound					Total
			L2	L	T	R	R2	
60th Street & Queensboro Bridge Exit 2019 (TMC-022)	1							
60th Street	1	EB	0	5	15	0	0	
60th Street	1	WB	0	0	0	0	0	
Queensboro Bridge Exit	1	NB	0	15	280	635	0	
	1	SB	0	0	0	0	0	950
60th Street & 3rd Ave 2019 (TMC-023)	2							
60th Street	2	EB	0	0	0	0	0	
60th Street	2	WB	0	0	265	275	0	
3rd Ave	2	NB	0	75	985	0	0	
	2	SB	0	0	0	0	0	1600
60th St & York Ave 2019 (TMC-024)	3							
60th St	3	EB	0	420	0	35	0	
60th St	3	WB	0	0	0	0	0	
York Ave	3	NB	0	0	525	0	0	
York Ave	3	SB	0	0	690	0	0	1670
59th St & 2nd Ave 2019 (TMC-025)	4							
Queensboro Bridge Exit (SWB)	4							
59th St	4	EB	0	0	670	90	70	
	4	WB	0	0	0	0	0	
	4	NB	0	0	0	0	0	
2nd Ave	4	SB	800	5	1585	0	0	3220
60th Street & 2nd Ave 2019 (TMC-026)	5	WB(bridge)						
Queensboro Bridge Exit (NWB)	5	NW	965	515	0	0	0	
60th St	5	EB	0	0	0	0	0	
60th St	5	WB	0	10	5	0	0	
	5	NB	0	0	0	0	0	
2nd Ave	5	SB	20	0	1415	20	0	1470
60th St & 1st Ave 2019 (TMC-027)	6							
60th Ave	6	EB	0	280	370	0	0	
	6	WB	0	0	0	0	0	
1st Ave	6	NB	0	0	955	85	0	
	6	SB	0	0	0	0	0	1690

60th St & Lexington Ave 2019 (TMC-028)	7							
	7	EB	0	0	0	0	0	
60th St	7	WB	0	65	275	0	0	
	7	NB	0	0	0	0	0	
Lexington Ave	7	SB	0	0	950	70	0	1360
60th St & Park Ave 2019 (TMC-029)	8							
	8	EB	0	0	0	0	0	
60th St	8	WB	0	0	270	75	0	
Park Ave	8	NB	0	65	910	0	0	
Park Ave	8	SB	0	0	0	0	0	1320
60th St & Park Ave 2019 (TMC-029)	888							
	888	EB	0	0	0	0	0	
60th St	888	WB	0	115	220	0	0	
Park Ave	888	NB	0	0	0	0	0	
Park Ave	888	SB	0	0	920	100	0	1355
60th St & Madison Ave 2019 (TMC-030)	9							
	9	EB	0	0	0	0	0	
60th St	9	WB	0	0	250	70	0	
Madison Ave	9	NB	0	110	660	0	0	
	9	SB	0	0	0	0	0	1090
62nd St & Queensboror Bridge Exit 2019 (TMC-031)	10							
62nd St	10	EB	0	0	210	0	0	
	10	WB	0	0	0	0	0	
Queensboro Bridge Exit	10	NB	0	0	775	745	0	
	10	SB	0	0	0	0	0	1730
60th St & 5th Ave 2019 (TMC-032)	11							
	11	EB	0	0	0	0	0	
60th St	11	WB	0	150	210	0	0	
	11	NB	0	0	0	0	0	
5th Ave	11	SB	0	0	640	290	0	1290

63rd St & York Ave 2019 (TMC-033)	12							
	12	EB	0	0	0	0	0	
63rd St	12	WB	0	320	260	65	0	
York Ave	12	NB	0	0	425	435	0	
York Ave	12	SB	0	430	465	70	0	2470
53rd St & FDR Drive 2019 (TMC-034)	13							
	13	EB	0	0	0	0	0	
53rd St	13	SW	0	0	0	355	0	
	13	NB	0	0	0	0	0	
FDR Drive	13	SB	0	0	0	150	0	505
61st St & 5th Ave 2019 (TMC-035)	14							
	14	EB	0	0	0	0	0	
61st St	14	WB	0	290	0	0	0	
	14	NB	0	0	0	0	0	
5th Ave	14	SB	0	0	640	0	0	930
65th St & 5th Ave 2019 (TMC-036)	15							
65th St	15	EB	0	0	640	300	0	
	15	WB	0	0	0	0	0	
	15	NB	0	0	0	0	0	
5th Ave	15	SB	0	85	535	0	0	1560
66th St & 5th Ave 2019 (TMC-037)	16							
	16	EB	0	0	0	0	0	
66th St	16	WB	0	80	475	0	0	
	16	NB	0	0	0	0	0	
5th Ave	16	SB	0	0	540	410	0	1505
79th St & 5th Ave 2019 (TMC-038)	17							
79th St	17	EB	0	0	460	190	0	
79th St	17	WB	0	70	545	0	0	
	17	NB	0	0	0	0	0	
5th Ave	17	SB	0	65	445	150	0	1925
71st St & York Ave 2019 (TMC-039)	18							
	18	EB	0	0	0	0	0	
71st St	18	WB	0	205	160	140	0	
York Ave	18	NB	0	65	395	0	0	
York Ave	18	SB	0	0	350	55	0	1370

CBD Tolling
UE #1 - Traffic Flowmap
PM Existing



- Legend:**
- 1 - Intersection (2019 Collected Data)
 - 7 - Intersection (Uncollected Data)
 - 100 - ATR Volume
 - 100 - Approach Volume

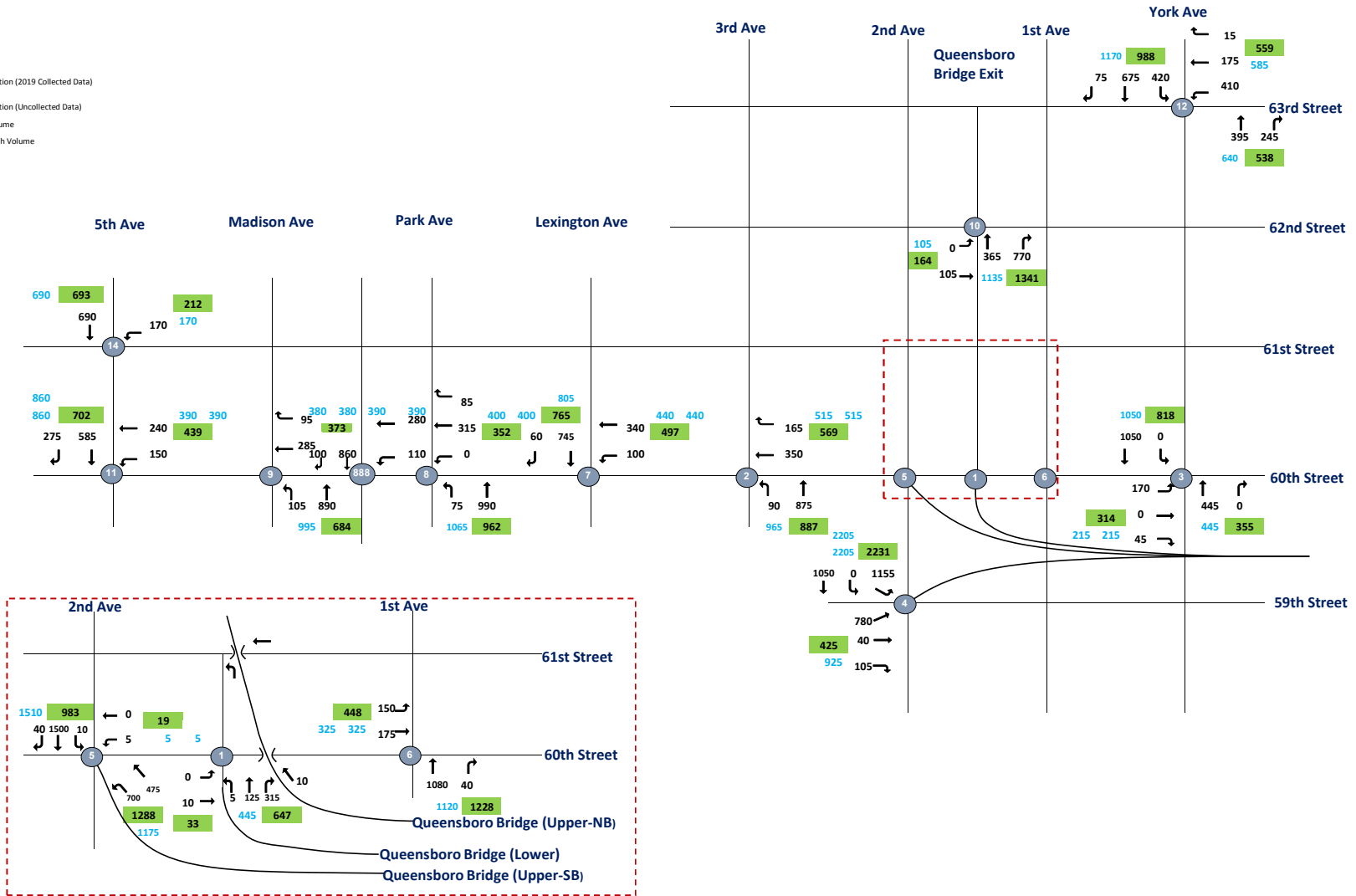

CBD Tolling
UE #2 - Traffic Flowmap
PM Existing



- Legend:**
- Intersection (2019 Collected Data)
 - Intersection (Uncollected Data)
 - 100 - ATR Volume
 - 100 - Approach Volume

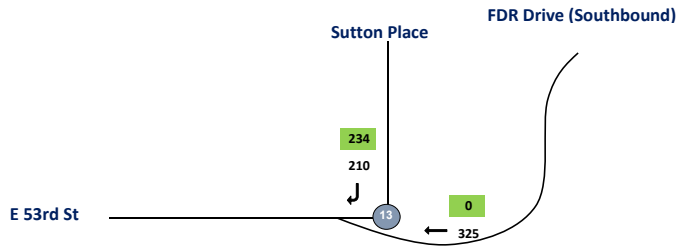

CBD Tolling
UE #3 - Traffic Flowmap
PM Existing



- Legend:**
- 1 - Intersection (2019 Collected Data)
 - 7 - Intersection (Uncollected Data)
 - 100 - ATR Volume
 - 100 - Approach Volume

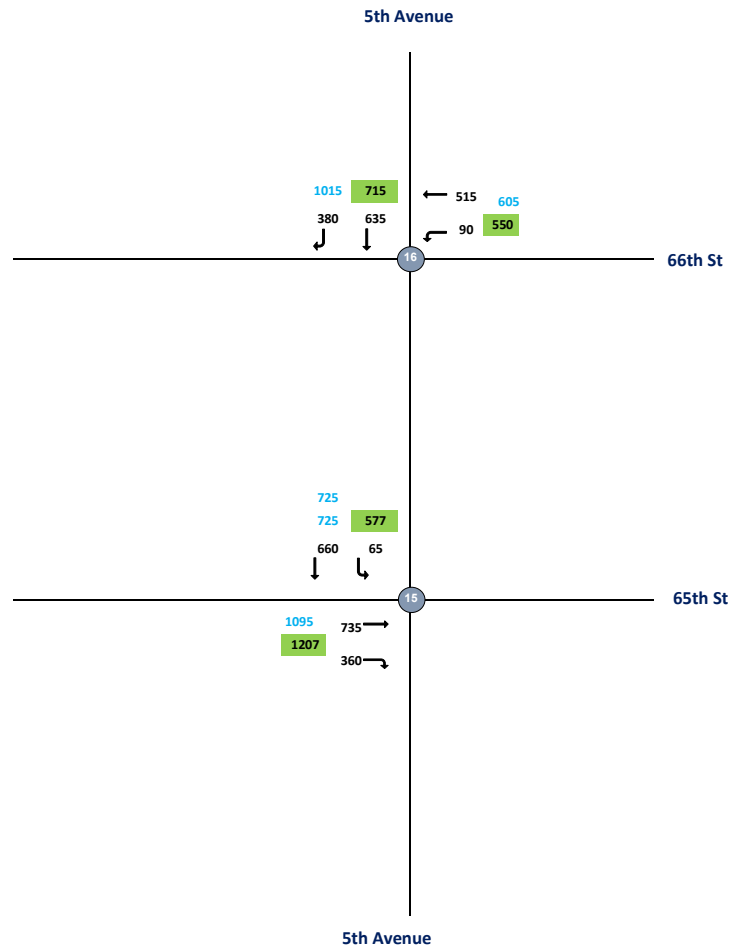

CBD Tolling
UE #3 - Traffic Flowmap
PM Existing



- Legend:**
- Intersection (2019 Collected Data)
 - Intersection (Uncollected Data)
 - 100 - ATR Volume
 - 100 - Approach Volume

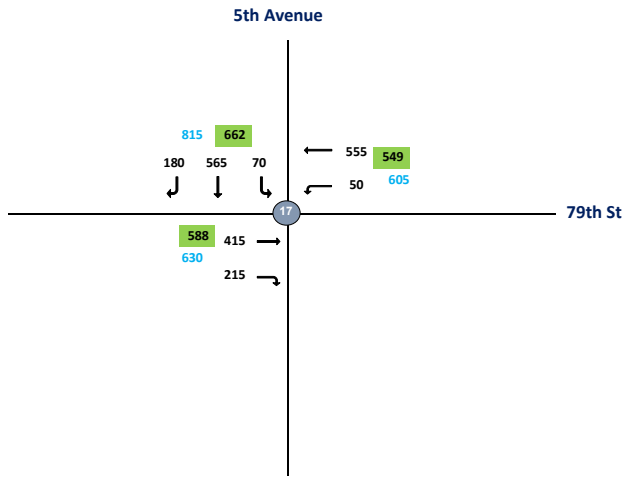

CBD Tolling
UE #4 - Traffic Flowmap
PM Existing



- Legend:**
- Intersection (2019 Collected Data)
 - Intersection (Uncollected Data)
 - 100 - ATR Volume
 - 100 - Approach Volume

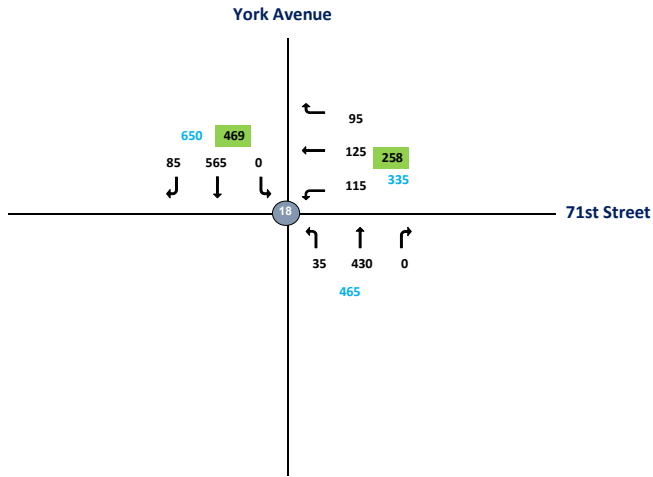

UE

5:00:00 PM

Intersection	Node	Approach	Total Vehicles					
			Inbound/Outbound					Total
			L2	L	T	R	R2	
60th Street & Queensboro Bridge Exit 2019 (TMC-022)	1							
60th Street	1	EB	0	0	10	0	0	
60th Street	1	WB	0	0	0	0	0	
Queensboro Bridge Exit	1	NB	0	5	125	315	0	
	1	SB	0	0	0	0	0	455
60th Street & 3rd Ave 2019 (TMC-023)	2							
60th Street	2	EB	0	0	0	0	0	
60th Street	2	WB	0	0	350	165	0	
3rd Ave	2	NB	0	90	875	0	0	
	2	SB	0	0	0	0	0	1480
60th St & York Ave 2019 (TMC-024)	3							
60th St	3	EB	0	170	0	45	0	
60th St	3	WB	0	0	0	0	0	
York Ave	3	NB	0	0	445	0	0	
York Ave	3	SB	0	0	1050	0	0	1710
59th St & 2nd Ave 2019 (TMC-025)	4							
Queensboro Bridge Exit (SWB)	4							
59th St	4	EB	0	0	780	40	105	
	4	WB	0	0	0	0	0	
	4	NB	0	0	0	0	0	
2nd Ave	4	SB	1155	0	1050	0	0	3130
60th Street & 2nd Ave 2019 (TMC-026)	5	WB(bridge)						
Queensboro Bridge Exit (NWB)	5	NW	700	475	0	0	0	
60th St	5	EB	0	0	0	0	0	
60th St	5	WB	0	5	0	0	0	
	5	NB	0	0	0	0	0	
2nd Ave	5	SB	10	0	1500	40	0	1555
60th St & 1st Ave 2019 (TMC-027)	6							
60th Ave	6	EB	0	150	175	0	0	
	6	WB	0	0	0	0	0	
1st Ave	6	NB	0	0	1080	40	0	
	6	SB	0	0	0	0	0	1445

60th St & Lexington Ave 2019 (TMC-028)	7							
	7	EB	0	0	0	0	0	
60th St	7	WB	0	100	340	0	0	
	7	NB	0	0	0	0	0	
Lexington Ave	7	SB	0	0	745	60	0	1245
60th St & Park Ave 2019 (TMC-029)	8							
	8	EB	0	0	0	0	0	
60th St	8	WB	0	0	315	85	0	
Park Ave	8	NB	0	75	990	0	0	
Park Ave	8	SB	0	0	0	0	0	1465
60th St & Park Ave 2019 (TMC-029)	888							
	888	EB	0	0	0	0	0	
60th St	888	WB	0	110	280	0	0	
Park Ave	888	NB	0	0	0	0	0	
Park Ave	888	SB	0	0	860	100	0	1350
60th St & Madison Ave 2019 (TMC-030)	9							
	9	EB	0	0	0	0	0	
60th St	9	WB	0	0	285	95	0	
Madison Ave	9	NB	0	105	890	0	0	
	9	SB	0	0	0	0	0	1375
62nd St & Queensboror Bridge Exit 2019 (TMC-031)	10							
62nd St	10	EB	0	0	105	0	0	
	10	WB	0	0	0	0	0	
Queensboro Bridge Exit	10	NB	0	0	365	770	0	
	10	SB	0	0	0	0	0	1240
60th St & 5th Ave 2019 (TMC-032)	11							
	11	EB	0	0	0	0	0	
60th St	11	WB	0	150	240	0	0	
	11	NB	0	0	0	0	0	
5th Ave	11	SB	0	0	585	275	0	1250

63rd St & York Ave 2019 (TMC-033)	12							
	12	EB	0	0	0	0	0	
63rd St	12	WB	0	410	175	15	0	
York Ave	12	NB	0	0	395	245	0	
York Ave	12	SB	0	420	675	75	0	2410
53rd St & FDR Drive 2019 (TMC-034)	13							
	13	EB	0	0	0	0	0	
53rd St	13	SW	0	0	0	325	0	
	13	NB	0	0	0	0	0	
FDR Drive	13	SB	0	0	0	210	0	535
61st St & 5th Ave 2019 (TMC-035)	14							
	14	EB	0	0	0	0	0	
61st St	14	WB	0	170	0	0	0	
	14	NB	0	0	0	0	0	
5th Ave	14	SB	0	0	690	0	0	860
65th St & 5th Ave 2019 (TMC-036)	15							
65th St	15	EB	0	0	735	360	0	
	15	WB	0	0	0	0	0	
	15	NB	0	0	0	0	0	
5th Ave	15	SB	0	65	660	0	0	1820
66th St & 5th Ave 2019 (TMC-037)	16							
	16	EB	0	0	0	0	0	
66th St	16	WB	0	90	515	0	0	
	16	NB	0	0	0	0	0	
5th Ave	16	SB	0	0	635	380	0	1620
79th St & 5th Ave 2019 (TMC-038)	17							
79th St	17	EB	0	0	415	215	0	
79th St	17	WB	0	50	555	0	0	
	17	NB	0	0	0	0	0	
5th Ave	17	SB	0	70	565	180	0	2050
71st St & York Ave 2019 (TMC-039)	18							
	18	EB	0	0	0	0	0	
71st St	18	WB	0	115	125	95	0	
York Ave	18	NB	0	35	430	0	0	
York Ave	18	SB	0	0	565	85	0	1450

CBD Tolling
UE #1 - Traffic Flowmap
LN Existing



- Legend:**
- ① - Intersection (2019 Collected Data)
 - ⑦ - Intersection (Uncollected Data)
 - 100 - ATR Volume
 - 100 - Approach Volume

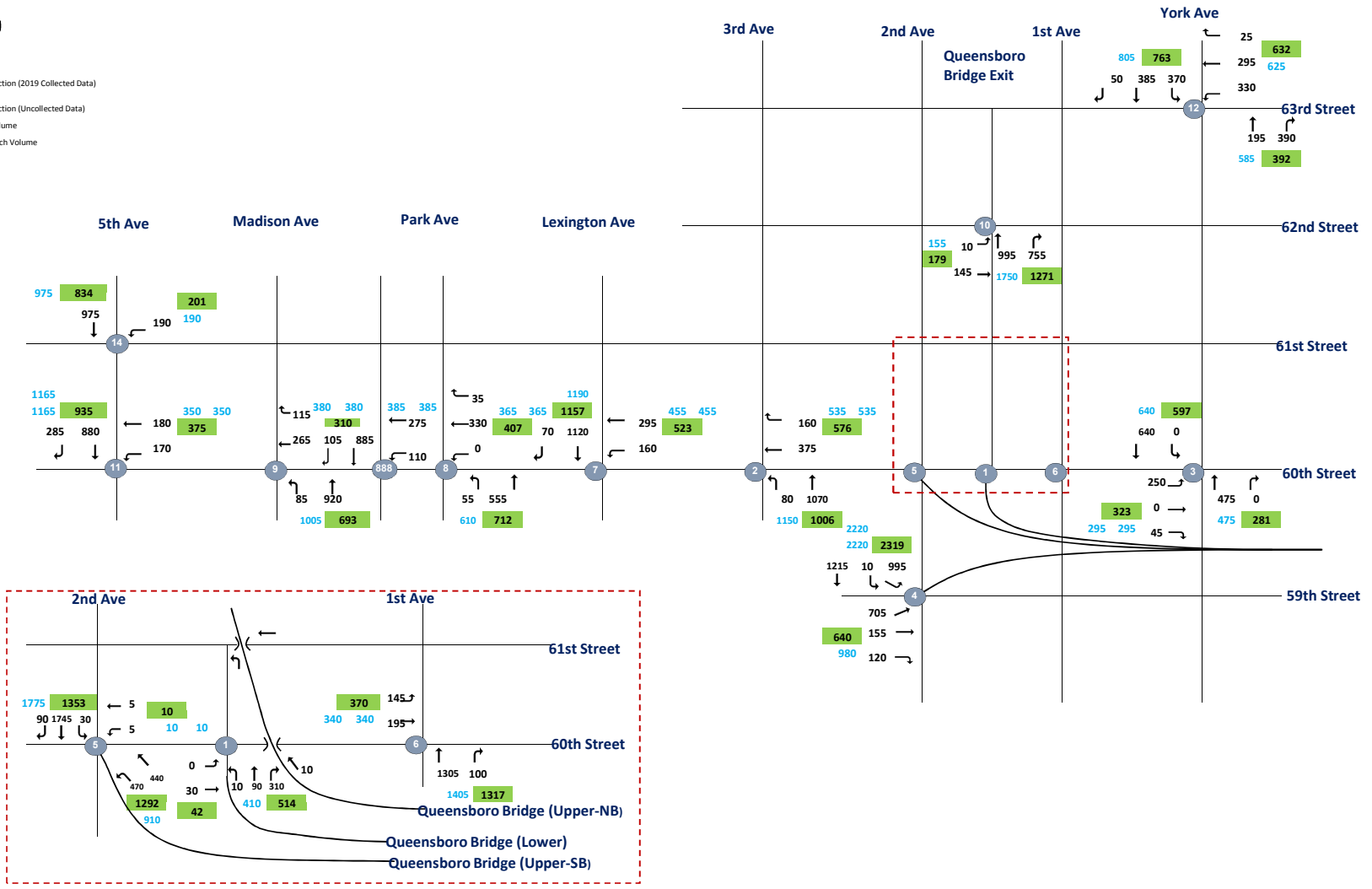

CBD Tolling
UE #2 - Traffic Flowmap
LN Existing



- Legend:**
- 1 - Intersection (2019 Collected Data)
 - 7 - Intersection (Uncollected Data)
 - 100 - ATR Volume
 - 100 - Approach Volume

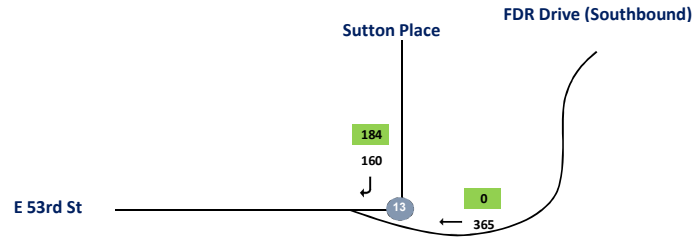

CBD Tolling
UE #3 - Traffic Flowmap
LN Existing



- Legend:**
- 1 - Intersection (2019 Collected Data)
 - 7 - Intersection (Uncollected Data)
 - 100 - ATR Volume
 - 100 - Approach Volume

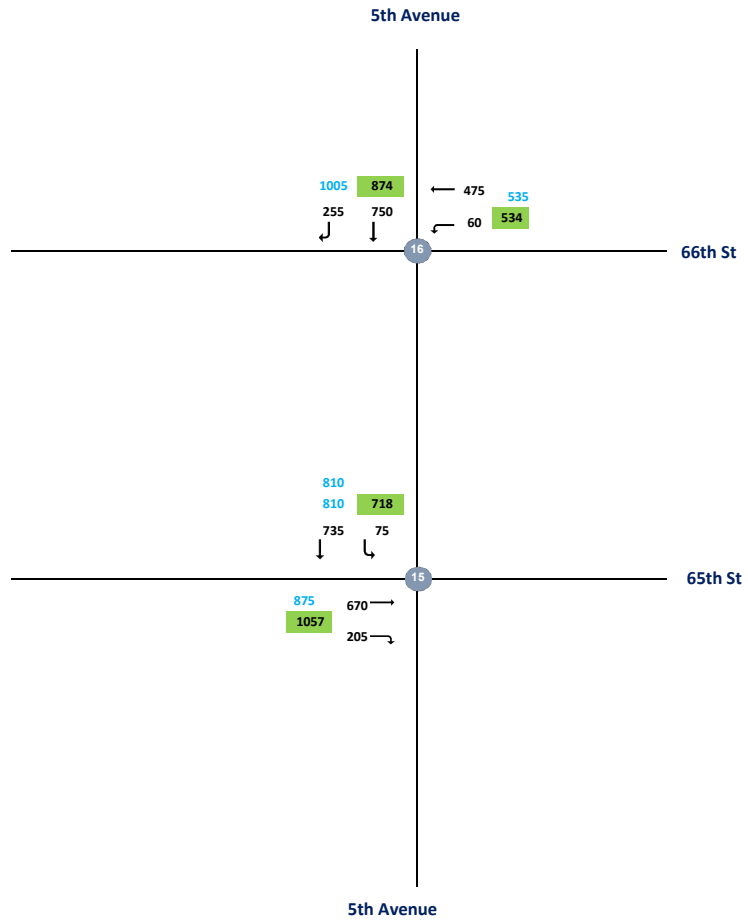

CBD Tolling
UE #3 - Traffic Flowmap
LN Existing



- Legend:**
- 1 - Intersection (2019 Collected Data)
 - 7 - Intersection (Uncollected Data)
 - 100 - ATR Volume
 - 100 - Approach Volume

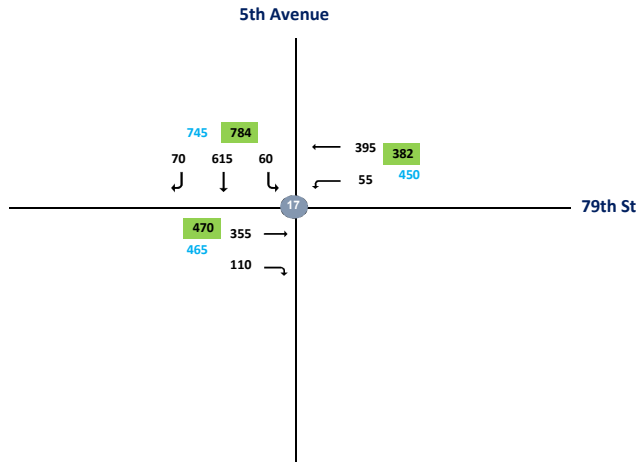

CBD Tolling
UE #4 - Traffic Flowmap
LN Existing



- Legend:**
- 1 - Intersection (2019 Collected Data)
 - 7 - Intersection (Uncollected Data)
 - 100 - ATR Volume
 - 100 - Approach Volume

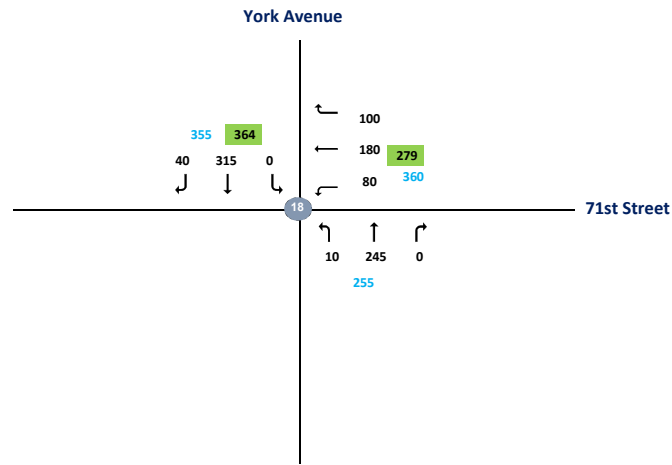

UE

9:00:00 PM

Intersection	Node	Approach	Total Vehicles					
			Inbound/Outbound					Total
			L2	L	T	R	R2	
60th Street & Queensboro Bridge Exit 2019 (TMC-022)	1							
60th Street	1	EB	0	0	30	0	0	
60th Street	1	WB	0	0	0	0	0	
Queensboro Bridge Exit	1	NB	0	10	90	310	0	
	1	SB	0	0	0	0	0	440
60th Street & 3rd Ave 2019 (TMC-023)	2							
60th Street	2	EB	0	0	0	0	0	
60th Street	2	WB	0	0	375	160	0	
3rd Ave	2	NB	0	80	1070	0	0	
	2	SB	0	0	0	0	0	1685
60th St & York Ave 2019 (TMC-024)	3							
60th St	3	EB	0	250	0	45	0	
60th St	3	WB	0	0	0	0	0	
York Ave	3	NB	0	0	475	0	0	
York Ave	3	SB	0	0	640	0	0	1410
59th St & 2nd Ave 2019 (TMC-025)	4							
Queensboro Bridge Exit (SWB)	4							
59th St	4	EB	0	0	705	155	120	
	4	WB	0	0	0	0	0	
	4	NB	0	0	0	0	0	
2nd Ave	4	SB	995	10	1215	0	0	3200
60th Street & 2nd Ave 2019 (TMC-026)	5	WB(bridge)						
Queensboro Bridge Exit (NWB)	5	NW	470	440	0	0	0	
60th St	5	EB	0	0	0	0	0	
60th St	5	WB	0	5	5	0	0	
	5	NB	0	0	0	0	0	
2nd Ave	5	SB	30	0	1745	90	0	1875
60th St & 1st Ave 2019 (TMC-027)	6							
60th Ave	6	EB	0	145	195	0	0	
	6	WB	0	0	0	0	0	
1st Ave	6	NB	0	0	1305	100	0	
	6	SB	0	0	0	0	0	1745

60th St & Lexington Ave 2019 (TMC-028)	7							
	7	EB	0	0	0	0	0	
60th St	7	WB	0	160	295	0	0	
	7	NB	0	0	0	0	0	
Lexington Ave	7	SB	0	0	1120	70	0	1645
60th St & Park Ave 2019 (TMC-029)	8							
	8	EB	0	0	0	0	0	
60th St	8	WB	0	0	330	35	0	
Park Ave	8	NB	0	55	555	0	0	
Park Ave	8	SB	0	0	0	0	0	975
60th St & Park Ave 2019 (TMC-029)	888							
	888	EB	0	0	0	0	0	
60th St	888	WB	0	110	275	0	0	
Park Ave	888	NB	0	0	0	0	0	
Park Ave	888	SB	0	0	885	105	0	1375
60th St & Madison Ave 2019 (TMC-030)	9							
	9	EB	0	0	0	0	0	
60th St	9	WB	0	0	265	115	0	
Madison Ave	9	NB	0	85	920	0	0	
	9	SB	0	0	0	0	0	1385
62nd St & Queensboror Bridge Exit 2019 (TMC-031)	10							
62nd St	10	EB	0	10	145	0	0	
	10	WB	0	0	0	0	0	
Queensboro Bridge Exit	10	NB	0	0	995	755	0	
	10	SB	0	0	0	0	0	1905
60th St & 5th Ave 2019 (TMC-032)	11							
	11	EB	0	0	0	0	0	
60th St	11	WB	0	170	180	0	0	
	11	NB	0	0	0	0	0	
5th Ave	11	SB	0	0	880	285	0	1515

63rd St & York Ave 2019 (TMC-033)	12							
	12	EB	0	0	0	0	0	
63rd St	12	WB	0	330	295	25	0	
York Ave	12	NB	0	0	195	390	0	
York Ave	12	SB	0	370	385	50	0	2040
53rd St & FDR Drive 2019 (TMC-034)	13							
	13	EB	0	0	0	0	0	
53rd St	13	SW	0	0	0	365	0	
	13	NB	0	0	0	0	0	
FDR Drive	13	SB	0	0	0	160	0	525
61st St & 5th Ave 2019 (TMC-035)	14							
	14	EB	0	0	0	0	0	
61st St	14	WB	0	190	0	0	0	
	14	NB	0	0	0	0	0	
5th Ave	14	SB	0	0	975	0	0	1165
65th St & 5th Ave 2019 (TMC-036)	15							
65th St	15	EB	0	0	670	205	0	
	15	WB	0	0	0	0	0	
	15	NB	0	0	0	0	0	
5th Ave	15	SB	0	75	735	0	0	1685
66th St & 5th Ave 2019 (TMC-037)	16							
	16	EB	0	0	0	0	0	
66th St	16	WB	0	60	475	0	0	
	16	NB	0	0	0	0	0	
5th Ave	16	SB	0	0	750	255	0	1540
79th St & 5th Ave 2019 (TMC-038)	17							
79th St	17	EB	0	0	355	110	0	
79th St	17	WB	0	55	395	0	0	
	17	NB	0	0	0	0	0	
5th Ave	17	SB	0	60	615	70	0	1660
71st St & York Ave 2019 (TMC-039)	18							
	18	EB	0	0	0	0	0	
71st St	18	WB	0	80	180	100	0	
York Ave	18	NB	0	10	245	0	0	
York Ave	18	SB	0	0	315	40	0	970

CBD Tolling
UW #1 - Traffic Flowmap
AM Existing



- Legend:**
- 1 - Intersection (2019 Collected Data)
 - 7 - Intersection (Uncollected Data)
 - 100 - ATR Volume
 - 100 - Approach Volume

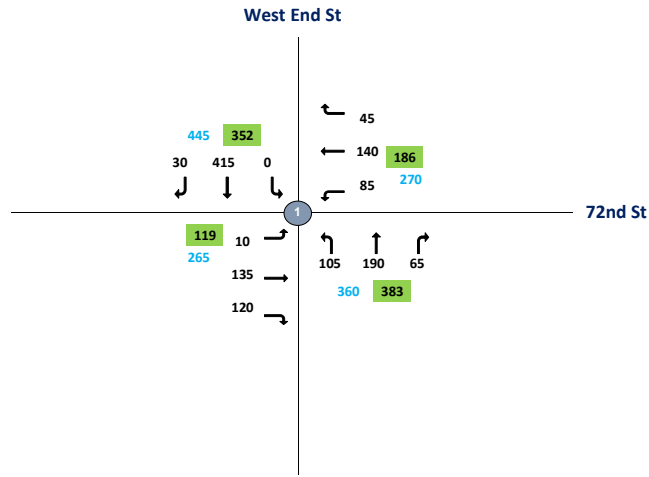

CBD Tolling
UW #2 - Traffic Flowmap
AM Existing



- Legend:**
- 1 - Intersection (2019 Collected Data)
 - 2 - Intersection (Uncollected Data)
 - 100 - ATR Volume
 - 100 - Approach Volume

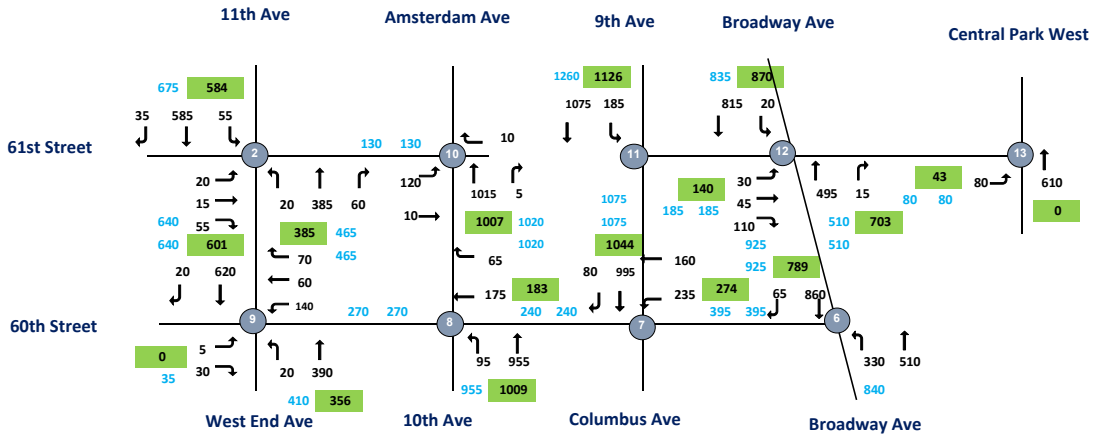

CBD Tolling
UW #3 - Traffic Flowmap
AM Existing



- Legend:**
- Intersection (2019 Collected Data)
 - Intersection (Uncollected Data)
 - 100 - ATR Volume
 - 100 - Approach Volume

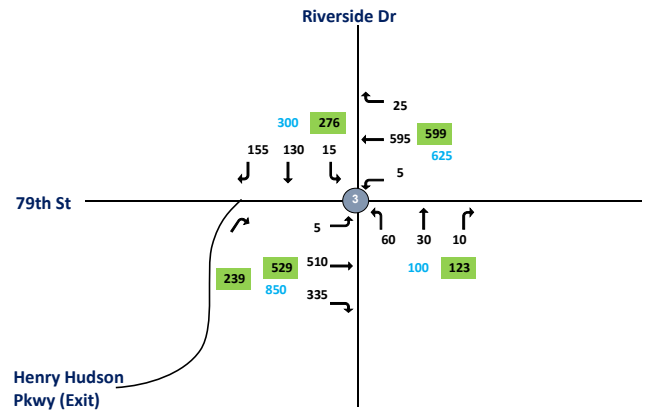

CBD Tolling
UW #4 - Traffic Flowmap
AM Existing



- Legend:**
- 1 - Intersection (2019 Collected Data)
 - 7 - Intersection (Uncollected Data)
 - 100 - ATR Volume
 - 100 - Approach Volume

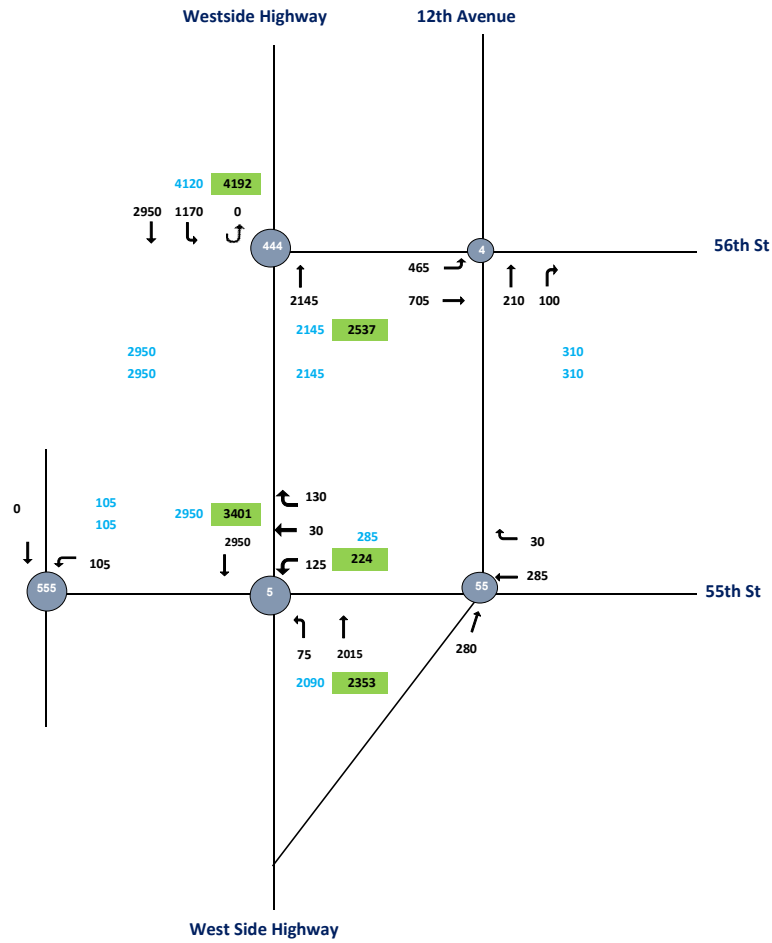

CBD Tolling
UW #5 - Traffic Flowmap
AM Existing



- Legend:**
- Intersection (2019 Collected Data)
 - Intersection (Uncollected Data)
 - ATR Volume
 - Approach Volume

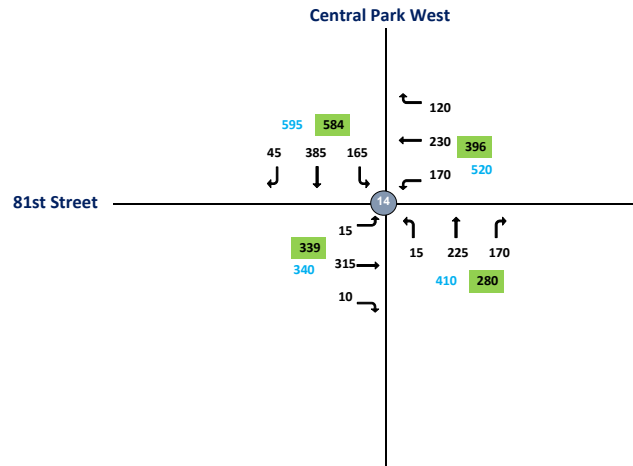

CBD Tolling
UW #6 - Traffic Flowmap
AM Existing



- Legend:**
- 1 - Intersection (2019 Collected Data)
 - 7 - Intersection (Uncollected Data)
 - 100 - ATR Volume
 - 100 - Approach Volume

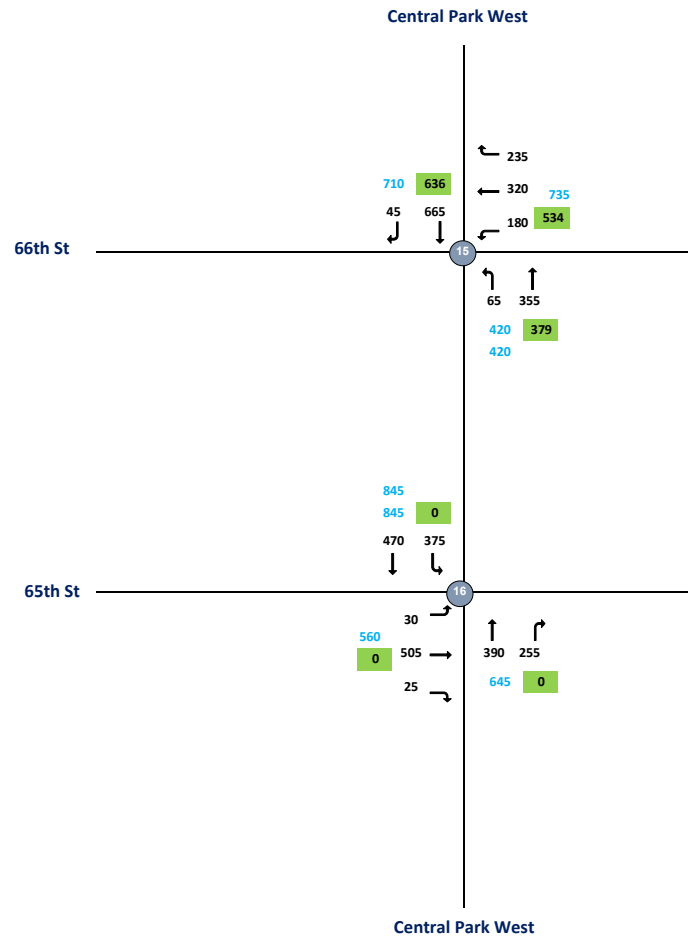

Intersection	Node	Approach	Total Vehicles					
			Inbound/Outbound					
			AM Peak Hour					
			L2	L	T	R	R2	Total
W 72nd St and West End St 2019 (TMC-042)	1							
W 72nd St	1	EB	0	10	135	120	0	
W 72nd St	1	WB	0	85	140	45	0	
West End St	1	NB	0	105	190	65	0	
West End St	1	SB	0	0	415	30	0	1340
W 61st St and West End St 2019 (TMC-043)	2							
W 61st St	2	EB	0	20	15	55	0	
W 61st St	2	WB	0	0	0	0	0	
West End St	2	NB	0	20	385	60	0	
West End St	2	SB	0	55	585	35	0	1230
W 79th St and Riverside Dr 2019 (TMC-044)	3	NEB						
W 79th St	3	EB	0	5	510	335	0	
W 79th St	3	WB	0	5	595	25	0	
Riverside Dr	3	NB	0	60	30	10	0	
Riverside Dr	3	SB	0	15	130	155	0	1875
W 79th St and Riverside Dr 2019 (TMC-044)	333							
W 79th St	333	EB	0	0	0	0	0	
W 79th St	333	WB	0	0	0	0	0	
Riverside Dr	333	NB	0	0	0	0	0	
Riverside Dr	333	SB	0	0	0	0	0	0
W 56th St and West Side Hwy 2019 (TMC-045)	4							
-	4	EB	0	465	705	0	0	
W 56th St	4	WB	0	0	0	0	0	
West Side Hwy	4	NB	0	0	210	100	0	
West Side Hwy	4	SB	0	0	0	0	0	1480
W 56th St and West Side Hwy 2019 (TMC-045)	444							
-	444	EB	0	0	0	0	0	
W 56th St	444	WB	0	0	0	0	0	
West Side Hwy	444	NB	0	0	2145	0	0	
West Side Hwy	444	SB	0	1170	2950	0	0	6265
W 55th St and West Side Hwy 2019 (TMC-046)	5							
-	5	EB	0	0	0	0	0	
W 55th St	5	WB	0	125	30	130	0	
West Side Hwy	5	NB	0	75	2015	0	0	
West Side Hwy	5	SB	0	0	2950	0	0	5325

W 55th St and West Side Hwy									
2019 (TMC-046 B B)		55							
-	55	EB	0	0	0	0	0		
W 55th St	55	WB	0	0	285	30	0		
West Side Hwy	55	NB	0	0	280	0	0		
West Side Hwy	55	SB	0	0	0	0	0		595
W 55th St and West Side Hwy									
2019 (TMC-046)		555							
-	555	EB	0	0	0	0	0		
W 55th St	555	WB	0	105	0	0	0		
West Side Hwy	555	NB	0	0	0	0	0		
West Side Hwy	555	SB	0	0	0	0	0		105
W 60th St and Broadway									
2019 (TMC-047)		6							
-	6	EB	0	0	0	0	0		
W 60th St	6	WB	0	0	0	0	0		
Broadway	6	NB	0	330	510	0	0		
Broadway	6	SB	0	0	860	65	0		1765
W 60th St and Columbus Ave									
2019 (TMC-048)		7							
W 60th St	7	EB	0	0	0	0	0		
W 60th St	7	WB	0	235	160	0	0		
Columbus Ave	7	NB	0	0	0	0	0		
Columbus Ave	7	SB	0	0	995	80	0		1470
W 60th St and 10th Ave									
2019 (TMC-049)		8							
W 60th St	8	EB	0	0	0	0	0		
W 60th St	8	WB	0	0	175	65	0		
10th Ave	8	NB	0	95	955	0	0		
10th Ave	8	SB	0	0	0	0	0		1290
W 60th St and 11th Ave									
2019 (TMC-050)		9							
W 60th St	9	EB	0	5	0	30	0		
W 60th St	9	WB	0	140	60	70	0		
11th Ave	9	NB	0	20	390	0	0		
11th Ave	9	SB	0	0	620	20	0		1355
W 61st St and 10th Ave									
2019 (TMC-051)		10							
W 61st St	10	EB	0	120	10	0	0		
W 61st St	10	WB	0	0	0	10	0		
10th Ave	10	NB	0	0	1015	5	0		
10th Ave	10	SB	0	0	0	0	0		1160

W 61st St and Columbus Ave									
2019 (TMC-052)	11								
-	11	EB	0	0	0	0	0		
W 61st St	11	WB	0	0	0	0	0		
Columbus Ave	11	NB	0	0	0	0	0		
Columbus Ave	11	SB	0	185	1075	0	0		1260
W 61st St and Broadway									
2019 (TMC-053)	12								
W 61st St	12	EB	0	30	45	110	0		
W 61st St	12	WB	0	0	0	0	0		
Broadway	12	NB	0	0	495	15	0		
Broadway	12	SB	0	20	815	0	0		1530
Central Park and W 61st St									
2019 (TMC-054)	13								
W 61st St	13	EB	0	80	0	0	0		
-	13	WB	0	0	0	0	0		
Central Park	13	NB	0	0	610	0	0		
Central Park	13	SB	0	0	0	0	0		690
Central Park and W 81st St									
2019 (TMC-055)	14								
W 81st St	14	EB	0	15	315	10	0		
W 79th St Transverse	14	WB	0	170	230	120	0		
Central Park	14	NB	0	15	225	170	0		
Central Park	14	SB	0	165	385	45	0		1865
Central Park West and W 66th St									
2019 (TMC-056)	15								
W 66th St	15	EB	0	0	0	0	0		
W 66th St	15	WB	0	180	320	235	0		
Central Park West	15	NB	0	65	355	0	0		
Central Park West	15	SB	0	0	665	45	0		1865
Central Park West and W 65th St									
2019 (TMC-057)	16								
W 65th St	16	EB	0	30	505	25	0		
W 65th St	16	WB	0	0	0	0	0		
Central Park West	16	NB	0	0	390	255	0		
Central Park West	16	SB	0	375	470	0	0		2050

CBD Tolling
UW #1 - Traffic Flowmap
MD Existing



- Legend:**
- 1 - Intersection (2019 Collected Data)
 - 7 - Intersection (Uncollected Data)
 - 100 - ATR Volume
 - 100 - Approach Volume

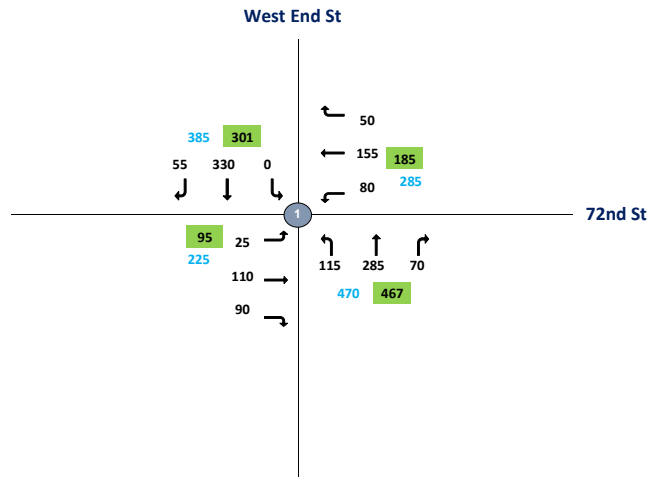

CBD Tolling
UW #2 - Traffic Flowmap
MD Existing



- Legend:**
- 1 - Intersection (2019 Collected Data)
 - 2 - Intersection (Uncollected Data)
 - 100 - ATR Volume
 - 100 - Approach Volume

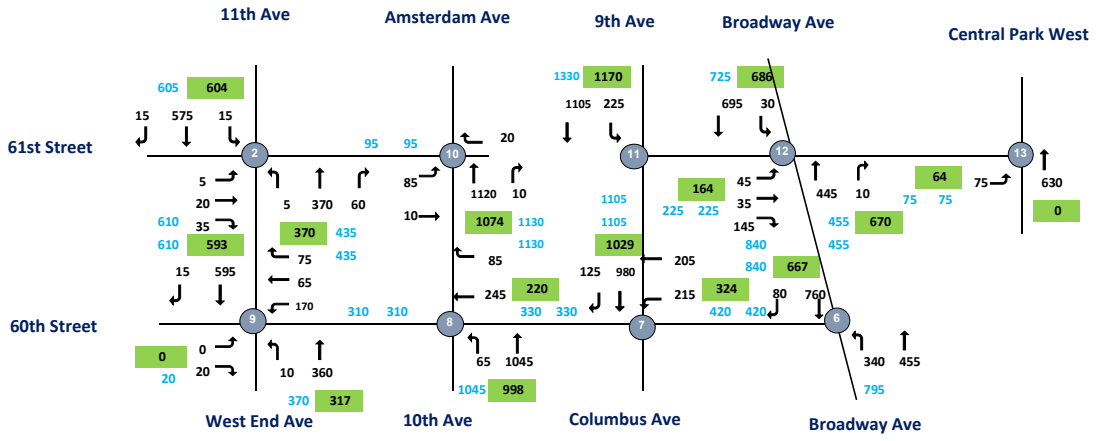

CBD Tolling
UW #3 - Traffic Flowmap
MD Existing



- Legend:**
- Intersection (2019 Collected Data)
 - Intersection (Uncollected Data)
 - 100 - ATR Volume
 - 100 - Approach Volume

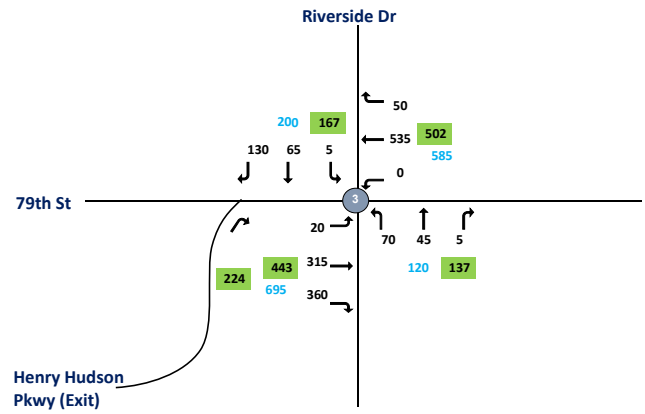

CBD Tolling
UW #4 - Traffic Flowmap
MD Existing



- Legend:**
- 1 - Intersection (2019 Collected Data)
 - 7 - Intersection (Uncollected Data)
 - 100 - ATR Volume
 - 100 - Approach Volume

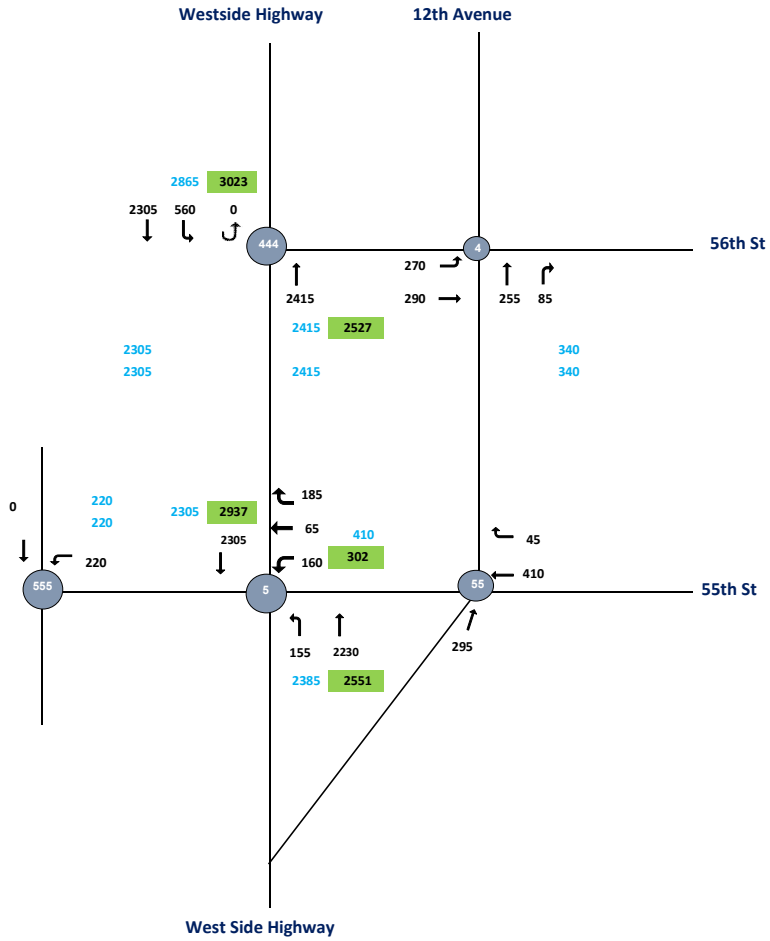

CBD Tolling
UW #5 - Traffic Flowmap
MD Existing



- Legend:**
- Intersection (2019 Collected Data)
 - 7 Intersection (Uncollected Data)
 - ATR Volume
 - Approach Volume

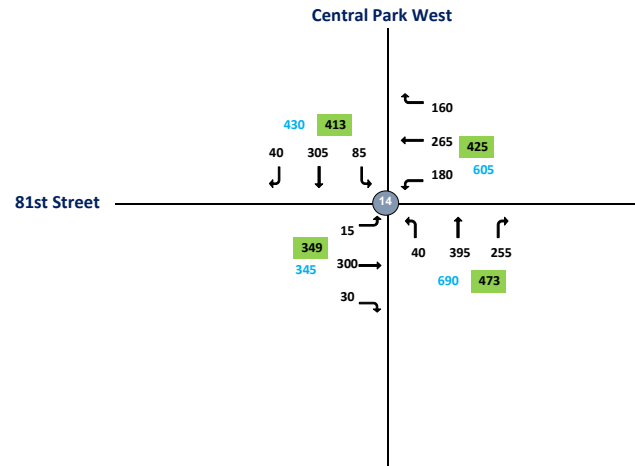

CBD Tolling
UW #6 - Traffic Flowmap
MD Existing



- Legend:**
- 1 - Intersection (2019 Collected Data)
 - 7 - Intersection (Uncollected Data)
 - 100 - ATR Volume
 - 100 - Approach Volume

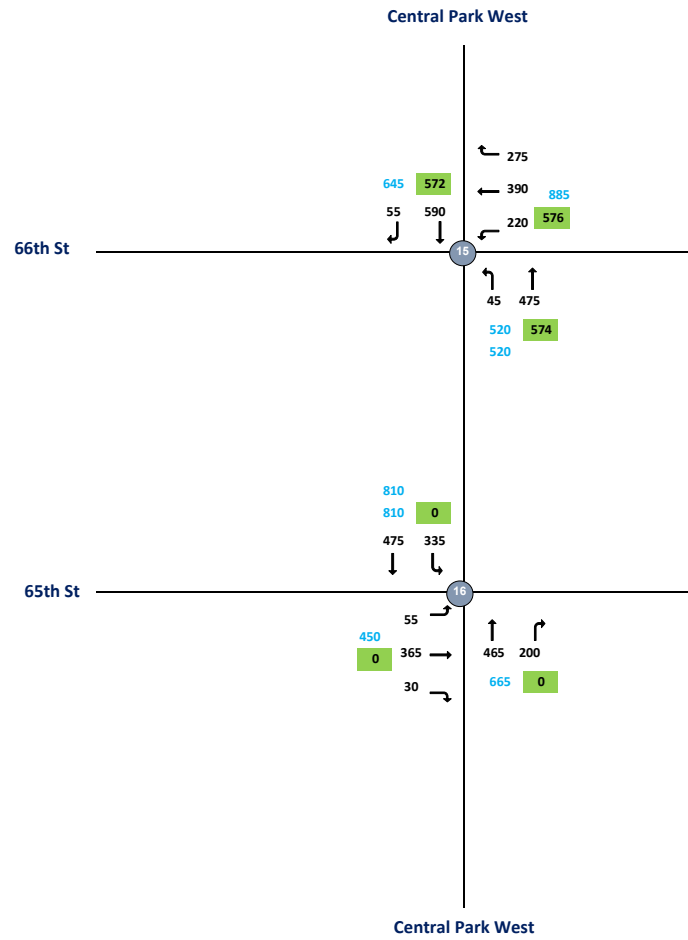

Intersection	Node	Approach	Total Vehicles					
			Inbound/Outbound					
			MD Peak Hour					
			L2	L	T	R	R2	Total
W 72nd St and West End St 2019 (TMC-042)	1							
W 72nd St	1	EB	0	25	110	90	0	
W 72nd St	1	WB	0	80	155	50	0	
West End St	1	NB	0	115	285	70	0	
West End St	1	SB	0	0	330	55	0	1365
W 61st St and West End St 2019 (TMC-043)	2							
W 61st St	2	EB	0	5	20	35	0	
W 61st St	2	WB	0	0	0	0	0	
West End St	2	NB	0	5	370	60	0	
West End St	2	SB	0	15	575	15	0	1100
W 79th St and Riverside Dr 2019 (TMC-044)	3	NEB						
W 79th St	3	EB	0	20	315	360	0	
W 79th St	3	WB	0	0	535	50	0	
Riverside Dr	3	NB	0	70	45	5	0	
Riverside Dr	3	SB	0	5	65	130	0	1600
W 79th St and Riverside Dr 2019 (TMC-044)	333							
W 79th St	333	EB	0	0	0	0	0	
W 79th St	333	WB	0	0	0	0	0	
Riverside Dr	333	NB	0	0	0	0	0	
Riverside Dr	333	SB	0	0	0	0	0	0
W 56th St and West Side Hwy 2019 (TMC-045)	4							
-	4	EB	0	270	290	0	0	
W 56th St	4	WB	0	0	0	0	0	
West Side Hwy	4	NB	0	0	255	85	0	
West Side Hwy	4	SB	0	0	0	0	0	900
W 56th St and West Side Hwy 2019 (TMC-045)	444							
-	444	EB	0	0	0	0	0	
W 56th St	444	WB	0	0	0	0	0	
West Side Hwy	444	NB	0	0	2415	0	0	
West Side Hwy	444	SB	0	560	2305	0	0	5280
W 55th St and West Side Hwy 2019 (TMC-046)	5							
-	5	EB	0	0	0	0	0	
W 55th St	5	WB	0	160	65	185	0	
West Side Hwy	5	NB	0	155	2230	0	0	
West Side Hwy	5	SB	0	0	2305	0	0	5100

W 55th St and West Side Hwy									
2019 (TMC-046 B)	55								
-	55	EB	0	0	0	0	0	0	
W 55th St	55	WB	0	0	410	45	0	0	
West Side Hwy	55	NB	0	0	295	0	0	0	
West Side Hwy	55	SB	0	0	0	0	0	0	750
W 55th St and West Side Hwy									
2019 (TMC-046 B)	555								
-	555	EB	0	0	0	0	0	0	
W 55th St	555	WB	0	220	0	0	0	0	
West Side Hwy	555	NB	0	0	0	0	0	0	
West Side Hwy	555	SB	0	0	0	0	0	0	220
W 60th St and Broadway									
2019 (TMC-047)	6								
-	6	EB	0	0	0	0	0	0	
W 60th St	6	WB	0	0	0	0	0	0	
Broadway	6	NB	0	340	455	0	0	0	
Broadway	6	SB	0	0	760	80	0	0	1635
W 60th St and Columbus Ave									
2019 (TMC-048)	7								
W 60th St	7	EB	0	0	0	0	0	0	
W 60th St	7	WB	0	215	205	0	0	0	
Columbus Ave	7	NB	0	0	0	0	0	0	
Columbus Ave	7	SB	0	0	980	125	0	0	1525
W 60th St and 10th Ave									
2019 (TMC-049)	8								
W 60th St	8	EB	0	0	0	0	0	0	
W 60th St	8	WB	0	0	245	85	0	0	
10th Ave	8	NB	0	65	1045	0	0	0	
10th Ave	8	SB	0	0	0	0	0	0	1440
W 60th St and 11th Ave									
2019 (TMC-050)	9								
W 60th St	9	EB	0	0	0	20	0	0	
W 60th St	9	WB	0	170	65	75	0	0	
11th Ave	9	NB	0	10	360	0	0	0	
11th Ave	9	SB	0	0	595	15	0	0	1310
W 61st St and 10th Ave									
2019 (TMC-051)	10								
W 61st St	10	EB	0	85	10	0	0	0	
W 61st St	10	WB	0	0	0	20	0	0	
10th Ave	10	NB	0	0	1120	10	0	0	
10th Ave	10	SB	0	0	0	0	0	0	1245

W 61st St and Columbus Ave									
2019 (TMC-052)	11								
-	11	EB	0	0	0	0	0	0	
W 61st St	11	WB	0	0	0	0	0	0	
Columbus Ave	11	NB	0	0	0	0	0	0	
Columbus Ave	11	SB	0	225	1105	0	0	0	1330
W 61st St and Broadway									
2019 (TMC-053)	12								
W 61st St	12	EB	0	45	35	145	0	0	
W 61st St	12	WB	0	0	0	0	0	0	
Broadway	12	NB	0	0	445	10	0	0	
Broadway	12	SB	0	30	695	0	0	0	1405
Central Park and W 61st St									
2019 (TMC-054)	13								
W 61st St	13	EB	0	75	0	0	0	0	
-	13	WB	0	0	0	0	0	0	
Central Park	13	NB	0	0	630	0	0	0	
Central Park	13	SB	0	0	0	0	0	0	705
Central Park and W 81st St									
2019 (TMC-055)	14								
W 81st St	14	EB	0	15	300	30	0	0	
W 79th St Transverse	14	WB	0	180	265	160	0	0	
Central Park	14	NB	0	40	395	255	0	0	
Central Park	14	SB	0	85	305	40	0	0	2070
Central Park West and W 66th St									
2019 (TMC-056)	15								
W 66th St	15	EB	0	0	0	0	0	0	
W 66th St	15	WB	0	220	390	275	0	0	
Central Park West	15	NB	0	45	475	0	0	0	
Central Park West	15	SB	0	0	590	55	0	0	2050
Central Park West and W 65th St									
2019 (TMC-057)	16								
W 65th St	16	EB	0	55	365	30	0	0	
W 65th St	16	WB	0	0	0	0	0	0	
Central Park West	16	NB	0	0	465	200	0	0	
Central Park West	16	SB	0	335	475	0	0	0	1925

CBD Tolling
UW #1 - Traffic Flowmap
PM Existing



- Legend:**
- 1 - Intersection (2019 Collected Data)
 - 7 - Intersection (Uncollected Data)
 - 100 - ATR Volume
 - 100 - Approach Volume

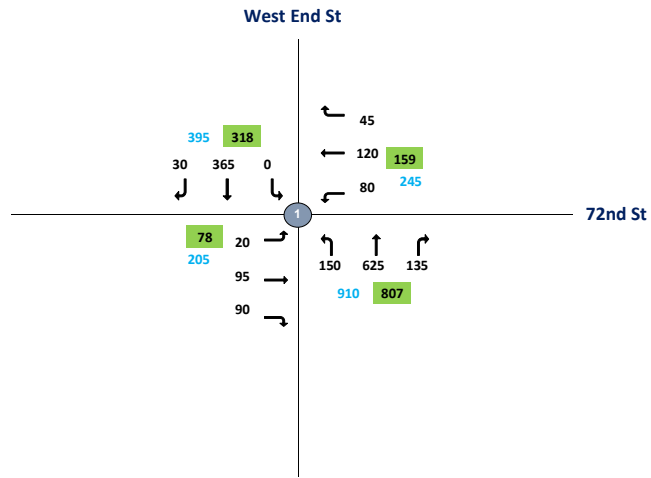

CBD Tolling
UW #2 - Traffic Flowmap
PM Existing



- Legend:**
- 1 - Intersection (2019 Collected Data)
 - 2 - Intersection (Uncollected Data)
 - 100 - ATR Volume
 - 100 - Approach Volume

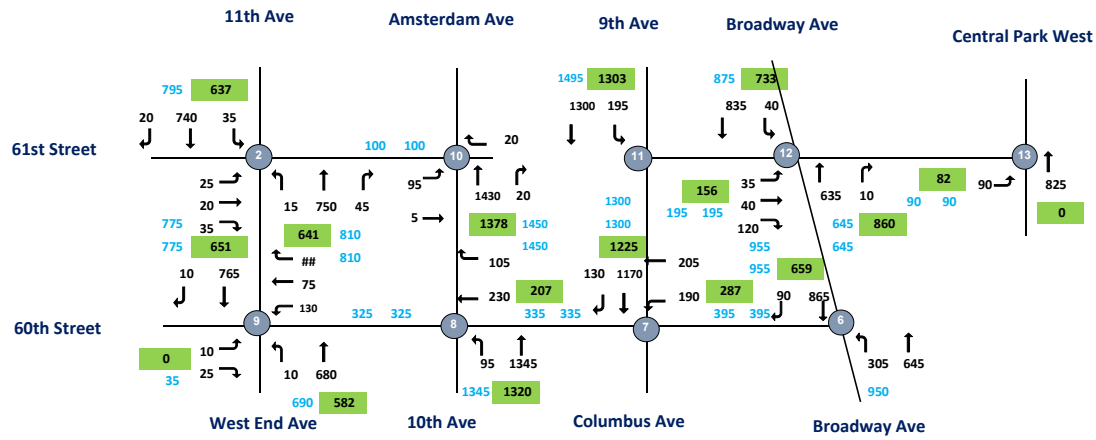

CBD Tolling
UW #3 - Traffic Flowmap
PM Existing



- Legend:**
- Intersection (2019 Collected Data)
 - Intersection (Uncollected Data)
 - ATR Volume
 - 100 - Approach Volume

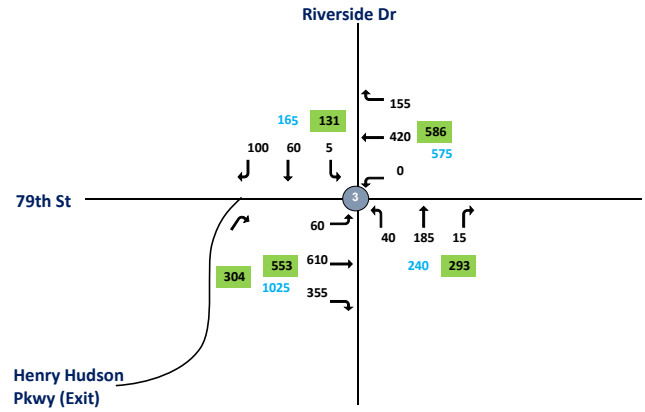

CBD Tolling
UW #4 - Traffic Flowmap
PM Existing



- Legend:**
- 1 - Intersection (2019 Collected Data)
 - 7 - Intersection (Uncollected Data)
 - 100 - ATR Volume
 - 100 - Approach Volume

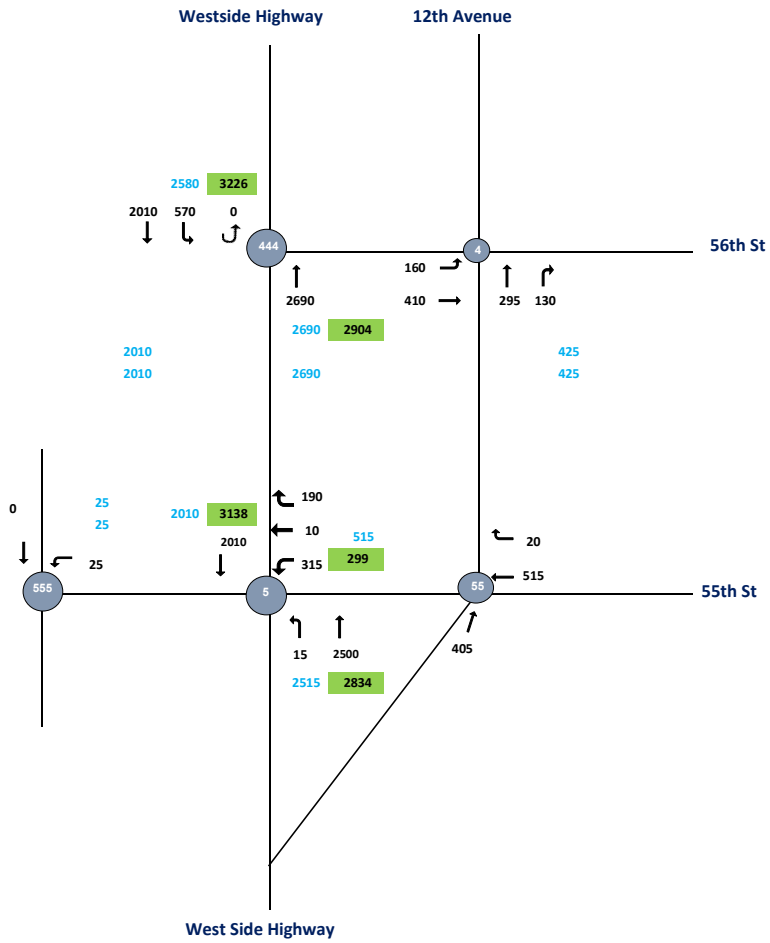

CBD Tolling
UW #5 - Traffic Flowmap
PM Existing



- Legend:**
- 1 - Intersection (2019 Collected Data)
 - 7 - Intersection (Uncollected Data)
 - 100 - ATR Volume
 - 100 - Approach Volume

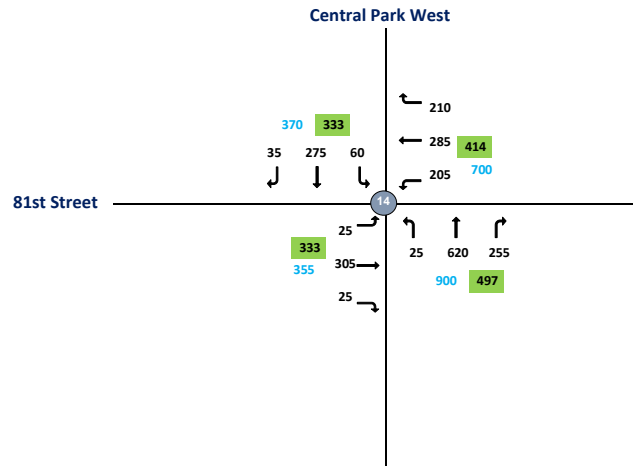

CBD Tolling
UW #6 - Traffic Flowmap
PM Existing



- Legend:**
- 1 - Intersection (2019 Collected Data)
 - 7 - Intersection (Uncollected Data)
 - 100 - ATR Volume
 - 100 - Approach Volume

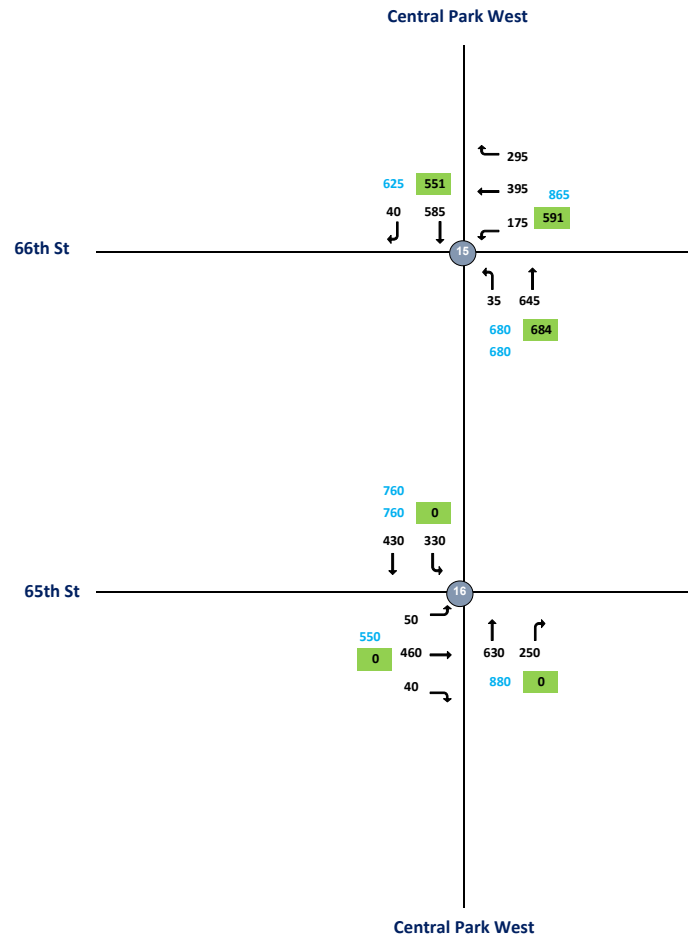

UW

5:00:00 PM

Intersection	Node	Approach	Total Vehicles					
			Inbound/Outbound					
			PM Peak Hour					
			L2	L	T	R	R2	Total
W 72nd St and West End St 2019 (TMC-042)	1							
W 72nd St	1	EB	0	20	95	90	0	
W 72nd St	1	WB	0	80	120	45	0	
West End St	1	NB	0	150	625	135	0	
West End St	1	SB	0	0	365	30	0	1755
W 61st St and West End St 2019 (TMC-043)	2							
W 61st St	2	EB	0	25	20	35	0	
W 61st St	2	WB	0	0	0	0	0	
West End St	2	NB	0	15	750	45	0	
West End St	2	SB	0	35	740	20	0	1685
W 79th St and Riverside Dr 2019 (TMC-044)	3	NEB						
W 79th St	3	EB	0	60	610	355	0	
W 79th St	3	WB	0	0	420	155	0	
Riverside Dr	3	NB	0	40	185	15	0	
Riverside Dr	3	SB	0	5	60	100	0	2005
W 79th St and Riverside Dr 2019 (TMC-044)	333							
W 79th St	333	EB	0	0	0	0	0	
W 79th St	333	WB	0	0	0	0	0	
Riverside Dr	333	NB	0	0	0	0	0	
Riverside Dr	333	SB	0	0	0	0	0	0
W 56th St and West Side Hwy 2019 (TMC-045)	4							
-	4	EB	0	160	410	0	0	
W 56th St	4	WB	0	0	0	0	0	
West Side Hwy	4	NB	0	0	295	130	0	
West Side Hwy	4	SB	0	0	0	0	0	995
W 56th St and West Side Hwy 2019 (TMC-045)	444							
-	444	EB	0	0	0	0	0	
W 56th St	444	WB	0	0	0	0	0	
West Side Hwy	444	NB	0	0	2690	0	0	
West Side Hwy	444	SB	0	570	2010	0	0	5270
W 55th St and West Side Hwy 2019 (TMC-046)	5							
-	5	EB	0	0	0	0	0	
W 55th St	5	WB	0	315	10	190	0	
West Side Hwy	5	NB	0	15	2500	0	0	
West Side Hwy	5	SB	0	0	2010	0	0	5040

W 55th St and West Side Hwy									
2019 (TMC-046 B)	55								
-	55	EB	0	0	0	0	0	0	
W 55th St	55	WB	0	0	515	20	0	0	
West Side Hwy	55	NB	0	0	405	0	0	0	
West Side Hwy	55	SB	0	0	0	0	0	0	940
W 55th St and West Side Hwy									
2019 (TMC-046)	555								
-	555	EB	0	0	0	5	0	0	
W 55th St	555	WB	0	25	0	0	0	0	
West Side Hwy	555	NB	0	0	0	0	0	0	
West Side Hwy	555	SB	0	0	0	0	0	0	30
W 60th St and Broadway									
2019 (TMC-047)	6								
-	6	EB	0	0	0	0	0	0	
W 60th St	6	WB	0	0	0	0	0	0	
Broadway	6	NB	0	305	645	0	0	0	
Broadway	6	SB	0	0	865	90	0	0	1905
W 60th St and Columbus Ave									
2019 (TMC-048)	7								
W 60th St	7	EB	0	0	0	0	0	0	
W 60th St	7	WB	0	190	205	0	0	0	
Columbus Ave	7	NB	0	0	0	0	0	0	
Columbus Ave	7	SB	0	0	1170	130	0	0	1695
W 60th St and 10th Ave									
2019 (TMC-049)	8								
W 60th St	8	EB	0	0	0	0	0	0	
W 60th St	8	WB	0	0	230	105	0	0	
10th Ave	8	NB	0	95	1345	0	0	0	
10th Ave	8	SB	0	0	0	0	0	0	1775
W 60th St and 11th Ave									
2019 (TMC-050)	9								
W 60th St	9	EB	0	10	0	25	0	0	
W 60th St	9	WB	0	130	75	120	0	0	
11th Ave	9	NB	0	10	680	0	0	0	
11th Ave	9	SB	0	0	765	10	0	0	1825
W 61st St and 10th Ave									
2019 (TMC-051)	10								
W 61st St	10	EB	0	95	5	0	0	0	
W 61st St	10	WB	0	0	0	20	0	0	
10th Ave	10	NB	0	0	1430	20	0	0	
10th Ave	10	SB	0	0	0	0	0	0	1570

W 61st St and Columbus Ave									
2019 (TMC-052)	11								
-	11	EB	0	0	0	0	0	0	
W 61st St	11	WB	0	0	0	0	0	0	
Columbus Ave	11	NB	0	0	0	0	0	0	
Columbus Ave	11	SB	0	195	1300	0	0	0	1495
W 61st St and Broadway									
2019 (TMC-053)	12								
W 61st St	12	EB	0	35	40	120	0	0	
W 61st St	12	WB	0	0	0	0	0	0	
Broadway	12	NB	0	0	635	10	0	0	
Broadway	12	SB	0	40	835	0	0	0	1715
Central Park and W 61st St									
2019 (TMC-054)	13								
W 61st St	13	EB	0	90	0	0	0	0	
-	13	WB	0	0	0	0	0	0	
Central Park	13	NB	0	0	825	0	0	0	
Central Park	13	SB	0	0	0	0	0	0	915
Central Park and W 81st St									
2019 (TMC-055)	14								
W 81st St	14	EB	0	25	305	25	0	0	
W 79th St Transverse	14	WB	0	205	285	210	0	0	
Central Park	14	NB	0	25	620	255	0	0	
Central Park	14	SB	0	60	275	35	0	0	2325
Central Park West and W 66th St									
2019 (TMC-056)	15								
W 66th St	15	EB	0	0	0	0	0	0	
W 66th St	15	WB	0	175	395	295	0	0	
Central Park West	15	NB	0	35	645	0	0	0	
Central Park West	15	SB	0	0	585	40	0	0	2170
Central Park West and W 65th St									
2019 (TMC-057)	16								
W 65th St	16	EB	0	50	460	40	0	0	
W 65th St	16	WB	0	0	0	0	0	0	
Central Park West	16	NB	0	0	630	250	0	0	
Central Park West	16	SB	0	330	430	0	0	0	2190

CBD Tolling
UW #1 - Traffic Flowmap
LN Existing



- Legend:**
- 1 - Intersection (2019 Collected Data)
 - 7 - Intersection (Uncollected Data)
 - 100 - ATR Volume
 - 100 - Approach Volume

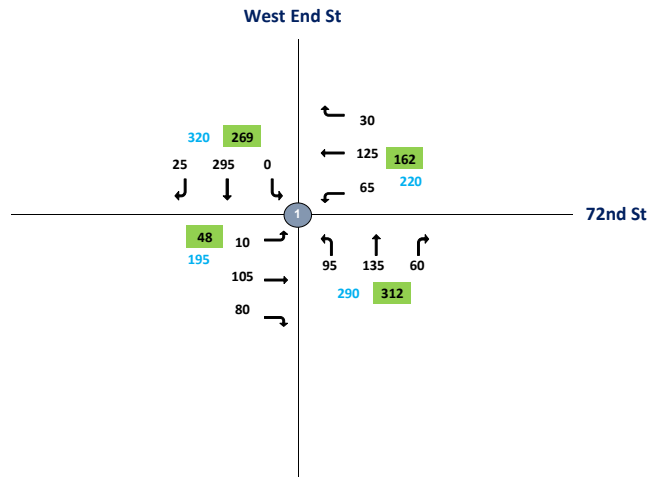

CBD Tolling
UW #2 - Traffic Flowmap
LN Existing



- Legend:**
- - Intersection (2019 Collected Data)
 - - Intersection (Uncollected Data)
 - 100 - ATR Volume
 - 100 - Approach Volume

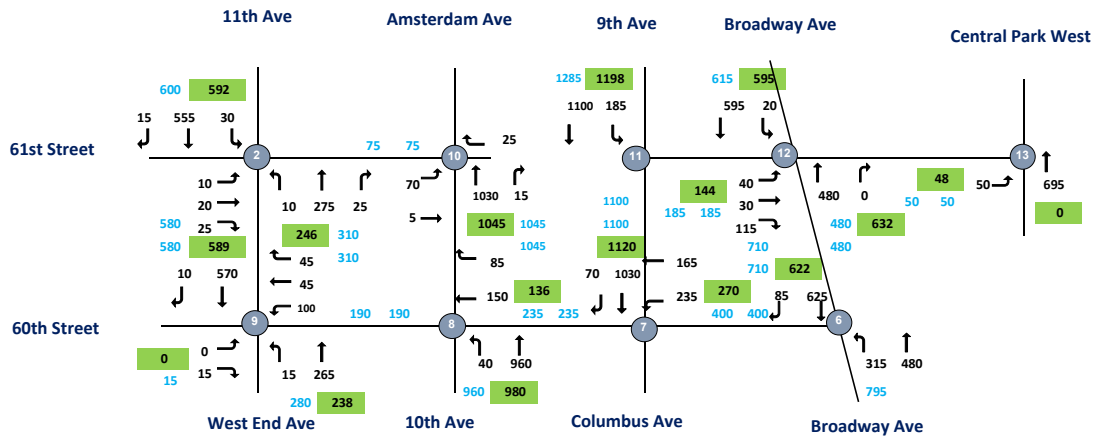

CBD Tolling
UW #3 - Traffic Flowmap
LN Existing



- Legend:**
- 1 - Intersection (2019 Collected Data)
 - 7 - Intersection (Uncollected Data)
 - 100 - ATR Volume
 - 100 - Approach Volume

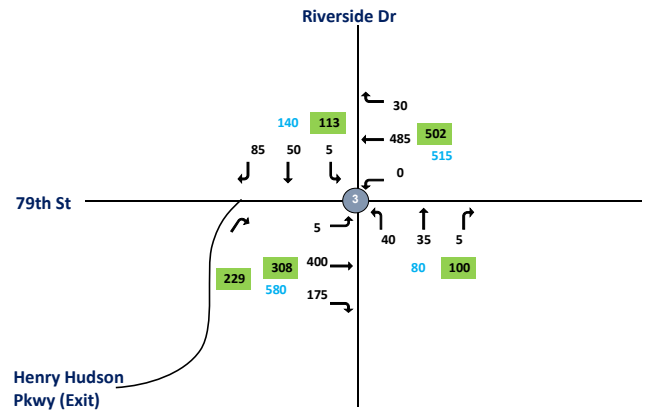

CBD Tolling
UW #4 - Traffic Flowmap
LN Existing



- Legend:**
- 1 - Intersection (2019 Collected Data)
 - 7 - Intersection (Uncollected Data)
 - 100 - ATR Volume
 - 100 - Approach Volume

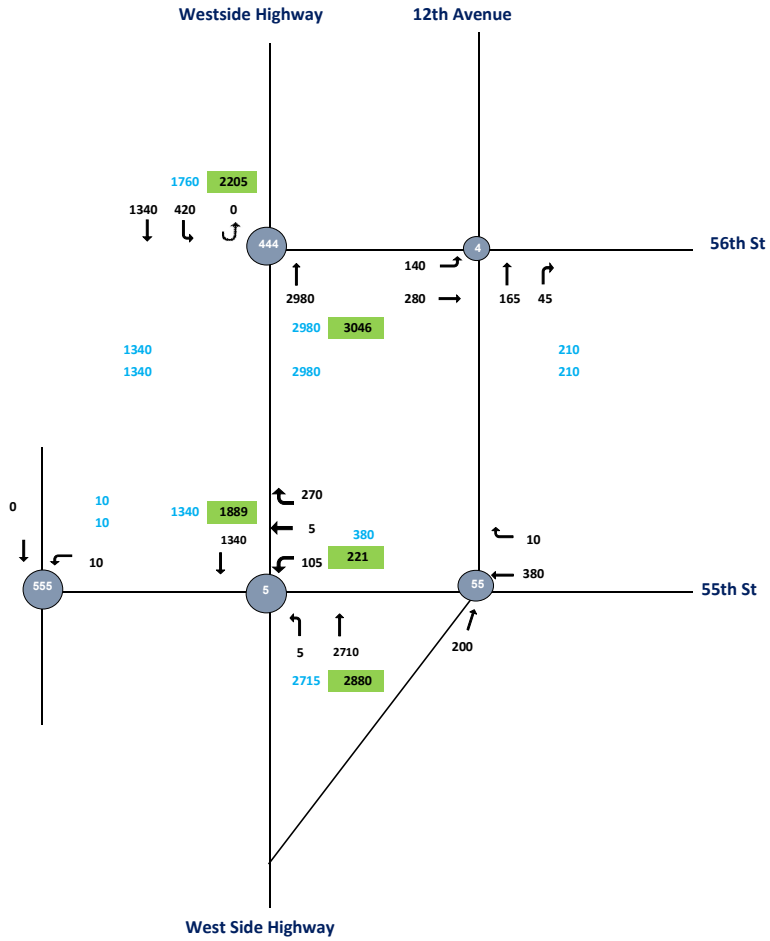

CBD Tolling
UW #5 - Traffic Flowmap
LN Existing



- Legend:**
- 1 - Intersection (2019 Collected Data)
 - 7 - Intersection (Uncollected Data)
 - 100 - ATR Volume
 - 100 - Approach Volume

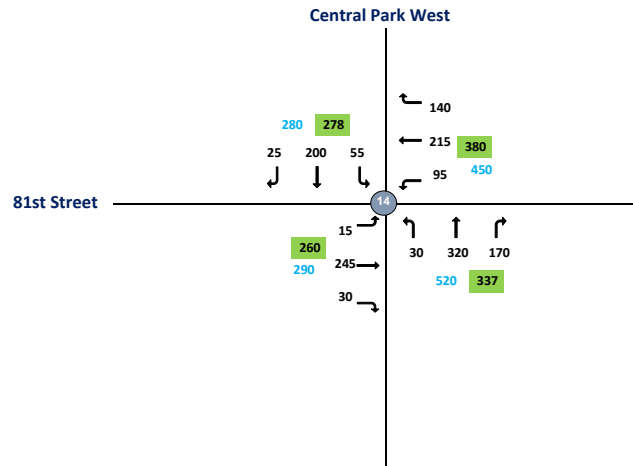

CBD Tolling
UW #6 - Traffic Flowmap
LN Existing



- Legend:**
- 1 - Intersection (2019 Collected Data)
 - 7 - Intersection (Uncollected Data)
 - 100 - ATR Volume
 - 100 - Approach Volume

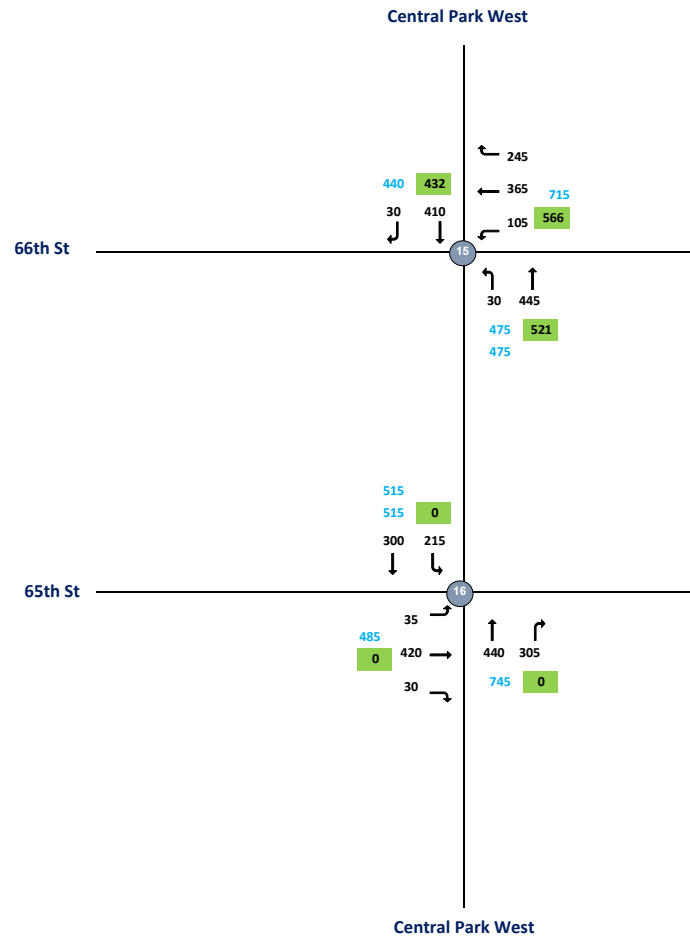

Intersection	Node	Approach	Total Vehicles					
			Inbound/Outbound					Total
			LN Peak Hour					
L2	L	T	R	R2				
W 72nd St and West End St 2019 (TMC-042)	1							
W 72nd St	1	EB	0	10	105	80	0	
W 72nd St	1	WB	0	65	125	30	0	
West End St	1	NB	0	95	135	60	0	
West End St	1	SB	0	0	295	25	0	1025
W 61st St and West End St 2019 (TMC-043)	2							
W 61st St	2	EB	0	10	20	25	0	
W 61st St	2	WB	0	0	0	0	0	
West End St	2	NB	0	10	275	25	0	
West End St	2	SB	0	30	555	15	0	965
W 79th St and Riverside Dr 2019 (TMC-044)	3	NEB						
W 79th St	3	EB	0	5	400	175	0	
W 79th St	3	WB	0	0	485	30	0	
Riverside Dr	3	NB	0	40	35	5	0	
Riverside Dr	3	SB	0	5	50	85	0	1315
W 79th St and Riverside Dr 2019 (TMC-044)	333							
W 79th St	333	EB	0	0	0	0	0	
W 79th St	333	WB	0	0	0	0	0	
Riverside Dr	333	NB	0	0	0	0	0	
Riverside Dr	333	SB	0	0	0	0	0	0
W 56th St and West Side Hwy 2019 (TMC-045)	4							
-	4	EB	0	140	280	0	0	
W 56th St	4	WB	0	0	0	0	0	
West Side Hwy	4	NB	0	0	165	45	0	
West Side Hwy	4	SB	0	0	0	0	0	630
W 56th St and West Side Hwy 2019 (TMC-045)	444							
-	444	EB	0	0	0	0	0	
W 56th St	444	WB	0	0	0	0	0	
West Side Hwy	444	NB	0	0	2980	0	0	
West Side Hwy	444	SB	0	420	1340	0	0	4740
W 55th St and West Side Hwy 2019 (TMC-046)	5							
-	5	EB	0	0	0	0	0	
W 55th St	5	WB	0	105	5	270	0	
West Side Hwy	5	NB	0	5	2710	0	0	
West Side Hwy	5	SB	0	0	1340	0	0	4435

W 55th St and West Side Hwy									
2019 (TMC-046 B)	55								
-	55	EB	0	0	0	0	0	0	
W 55th St	55	WB	0	0	380	10	0	0	
West Side Hwy	55	NB	0	0	200	0	0	0	
West Side Hwy	55	SB	0	0	0	0	0	0	590
W 55th St and West Side Hwy									
2019 (TMC-046)	555								
-	555	EB	0	0	0	0	0	0	
W 55th St	555	WB	0	10	0	0	0	0	
West Side Hwy	555	NB	0	0	0	0	0	0	
West Side Hwy	555	SB	0	0	0	0	0	0	10
W 60th St and Broadway									
2019 (TMC-047)	6								
-	6	EB	0	0	0	0	0	0	
W 60th St	6	WB	0	0	0	0	0	0	
Broadway	6	NB	0	315	480	0	0	0	
Broadway	6	SB	0	0	625	85	0	0	1505
W 60th St and Columbus Ave									
2019 (TMC-048)	7								
W 60th St	7	EB	0	0	0	0	0	0	
W 60th St	7	WB	0	235	165	0	0	0	
Columbus Ave	7	NB	0	0	0	0	0	0	
Columbus Ave	7	SB	0	0	1030	70	0	0	1500
W 60th St and 10th Ave									
2019 (TMC-049)	8								
W 60th St	8	EB	0	0	0	0	0	0	
W 60th St	8	WB	0	0	150	85	0	0	
10th Ave	8	NB	0	40	960	0	0	0	
10th Ave	8	SB	0	0	0	0	0	0	1235
W 60th St and 11th Ave									
2019 (TMC-050)	9								
W 60th St	9	EB	0	0	0	15	0	0	
W 60th St	9	WB	0	100	45	45	0	0	
11th Ave	9	NB	0	15	265	0	0	0	
11th Ave	9	SB	0	0	570	10	0	0	1065
W 61st St and 10th Ave									
2019 (TMC-051)	10								
W 61st St	10	EB	0	70	5	0	0	0	
W 61st St	10	WB	0	0	0	25	0	0	
10th Ave	10	NB	0	0	1030	15	0	0	
10th Ave	10	SB	0	0	0	0	0	0	1145

W 61st St and Columbus Ave									
2019 (TMC-052)	11								
-	11	EB	0	0	0	0	0	0	
W 61st St	11	WB	0	0	0	0	0	0	
Columbus Ave	11	NB	0	0	0	0	0	0	
Columbus Ave	11	SB	0	185	1100	0	0	0	1285
W 61st St and Broadway									
2019 (TMC-053)	12								
W 61st St	12	EB	0	40	30	115	0	0	
W 61st St	12	WB	0	0	0	0	0	0	
Broadway	12	NB	0	0	480	0	0	0	
Broadway	12	SB	0	20	595	0	0	0	1280
Central Park and W 61st St									
2019 (TMC-054)	13								
W 61st St	13	EB	0	50	0	0	0	0	
-	13	WB	0	0	0	0	0	0	
Central Park	13	NB	0	0	695	0	0	0	
Central Park	13	SB	0	0	0	0	0	0	745
Central Park and W 81st St									
2019 (TMC-055)	14								
W 81st St	14	EB	0	15	245	30	0	0	
W 79th St Transverse	14	WB	0	95	215	140	0	0	
Central Park	14	NB	0	30	320	170	0	0	
Central Park	14	SB	0	55	200	25	0	0	1540
Central Park West and W 66th St									
2019 (TMC-056)	15								
W 66th St	15	EB	0	0	0	0	0	0	
W 66th St	15	WB	0	105	365	245	0	0	
Central Park West	15	NB	0	30	445	0	0	0	
Central Park West	15	SB	0	0	410	30	0	0	1630
Central Park West and W 65th St									
2019 (TMC-057)	16								
W 65th St	16	EB	0	35	420	30	0	0	
W 65th St	16	WB	0	0	0	0	0	0	
Central Park West	16	NB	0	0	440	305	0	0	
Central Park West	16	SB	0	215	300	0	0	0	1745

CBD Tolling
9A - Traffic Flowmap
AM No-Action Increment



- Legend:**
- ① - Intersection (2019 Collected Data)
 - ⑦ - Intersection (Uncollected Data)
 - 100 - ATR Volume
 - 100 - Approach Volume

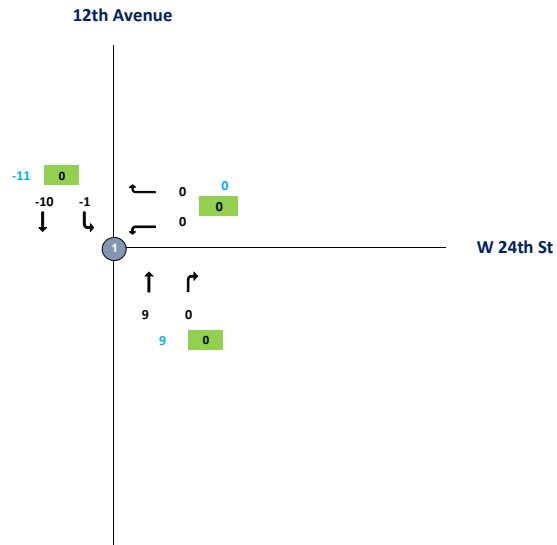

9A

8:00 AM

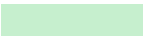

Intersection	Node	Approach	Total Vehicles					
			Inbound/Outbound					
			AM Peak Hour					
			L2	L	T	R	R2	Total
12th Ave & 24th Street 2019 (TMC-065)	1							
24th Street	1	EB	0	0	0	0	0	
24th Street	1	WB	0	0	0	0	0	
12th Ave	1	NB	0	0	9	0	0	
12th Ave	1	SB	0	-1	-10	0	0	-2

CBD Tolling
9A - Traffic Flowmap
MD No-Action Increment



- Legend:**
- 1 - Intersection (2019 Collected Data)
 - 7 - Intersection (Uncollected Data)
 - 100 - ATR Volume
 - 100 - Approach Volume

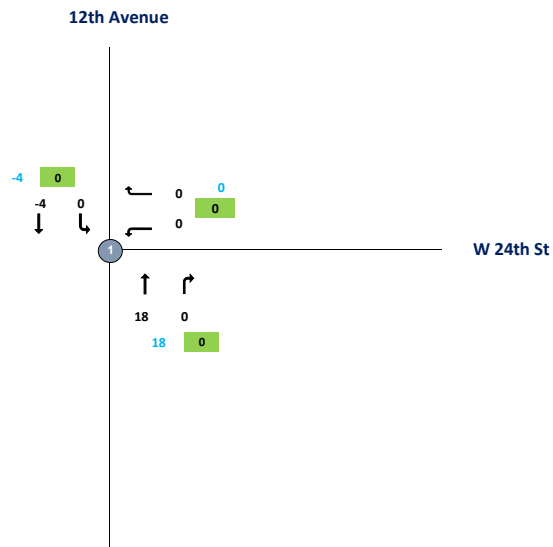

9A

1:00 PM

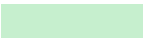

Intersection	Node	Approach	Total Vehicles					
			Inbound/Outbound					
			MD Peak Hour					
			L2	L	T	R	R2	Total
12th Ave & 24th Street 2019 (TMC-065)	1							
24th Street	1	EB	0	0	0	0	0	
24th Street	1	WB	0	0	0	0	0	
12th Ave	1	NB	0	0	18	0	0	
12th Ave	1	SB	0	0	-4	0	0	14

CBD Tolling
9A - Traffic Flowmap
PM No-Action Increment



- Legend:**
- 1 - Intersection (2019 Collected Data)
 - 7 - Intersection (Uncollected Data)
 - 100 - ATR Volume
 - 100 - Approach Volume

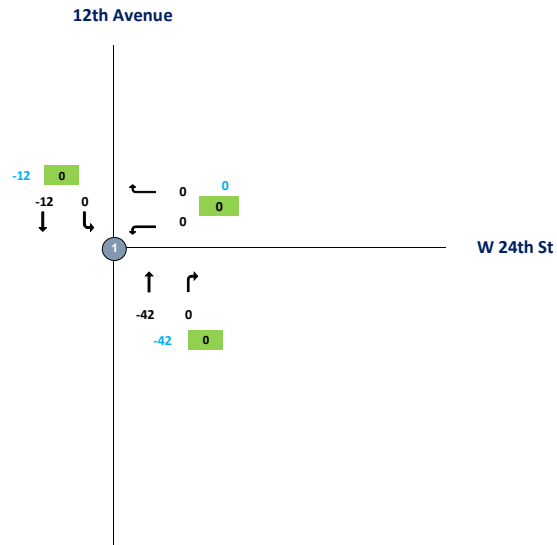

9A

5:00 PM

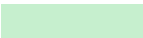

Intersection	Node	Approach	Total Vehicles					
			Inbound/Outbound					
			PM Peak Hour					
			L2	L	T	R	R2	Total
12th Ave & 24th Street 2019 (TMC-065)	1							
24th Street	1	EB	0	0	0	0	0	
24th Street	1	WB	0	0	0	0	0	
12th Ave	1	NB	0	0	-42	0	0	
12th Ave	1	SB	0	0	-12	0	0	-54

CBD Tolling
9A - Traffic Flowmap
LN No-Action Increment



- Legend:**
- ① - Intersection (2019 Collected Data)
 - ⑦ - Intersection (Uncollected Data)
 - 100 - ATR Volume
 - 100 - Approach Volume

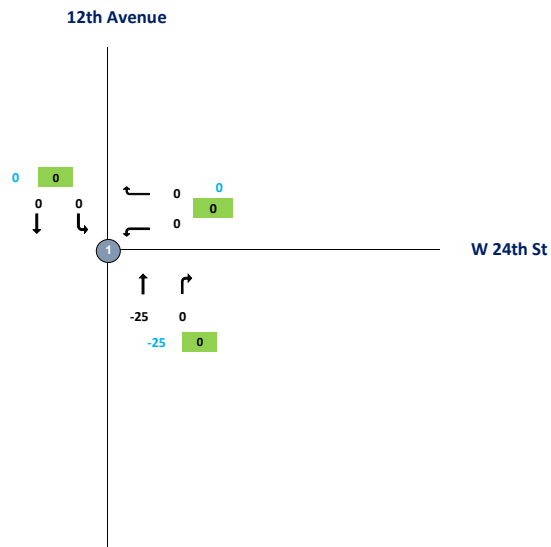

9A

9:00 PM

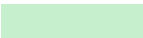

Intersection	Node	Approach	Total Vehicles					
			Inbound/Outbound					
			LN Peak Hour					
			L2	L	T	R	R2	Total
12th Ave & 24th Street 2019 (TMC-065)	1							
24th Street	1	EB	0	0	0	0	0	
24th Street	1	WB	0	0	0	0	0	
12th Ave	1	NB	0	0	-25	0	0	
12th Ave	1	SB	0	0	0	0	0	-25

CBD Tolling
Dumbo - Traffic Flowmap
AM No-Action Increment



- Legend:**
- 1 - Intersection (2019 Collected Data)
 - 7 - Intersection (Uncollected Data)
 - 100 - ATR Volume
 - 100 - Approach Volume

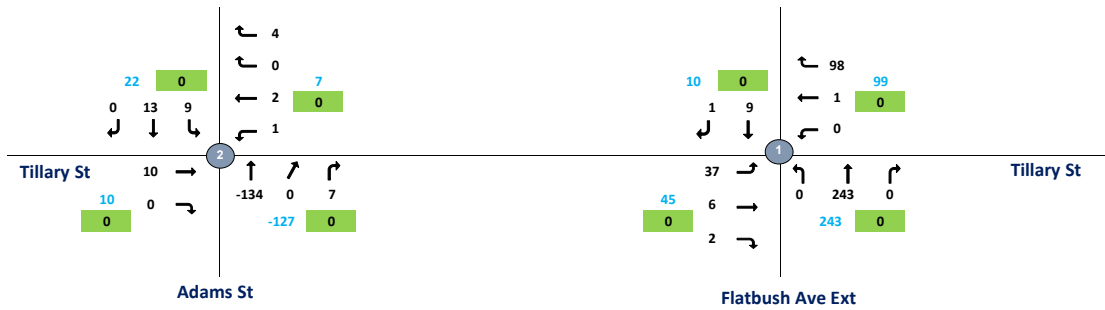

CBD Tolling
Dumbo #2 - Traffic Flowmap
AM No-Action Increment



- Legend:**
- Intersection (2019 Collected Data)
 - Intersection (Uncollected Data)
 - ATR Volume
 - Approach Volume

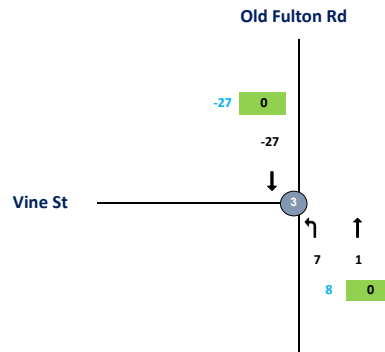

DUMBO

8:00:00 AM

Intersection	Node	Approach	Total Vehicles					Total
			Inbound/Outbound					
			AM Peak Hour					
			L2	L	T	R	R2	
Tillary St & Flatbush Ave ext 2019 (TMC-007)	1							
Tillary St	1	EB	0	37	6	2	0	
Tillary St	1	WB	0	0	1	98	0	
Flatbush Ave ext	1	NB	0	0	243	0	0	
Flatbush Ave ext	1	SB	0	0	9	1	0	397
Tillary St & Adams St 2019 (TMC-008)	2							
Tillary St	2	EB	0	0	10	0	0	
Tillary St	2	WB	0	1	2	0	4	
Adams St	2	NB	0	0	-134	0	7	
Adams St	2	SB	0	9	13	0	0	-88
Vine St & Old Fulton Rd 2019 (TMC-009)	3							
Vine St	3	EB	0	0	0	0	0	
Vine St	3	WB	0	0	0	0	0	
Old Fulton Rd	3	NB	0	7	1	0	0	
Old Fulton Rd	3	SB	0	0	-27	0	0	-19

CBD Tolling
Dumbo - Traffic Flowmap
MD No-Action Increment



- Legend:**
- 1 - Intersection (2019 Collected Data)
 - 7 - Intersection (Uncollected Data)
 - 100 - ATR Volume
 - 100 - Approach Volume

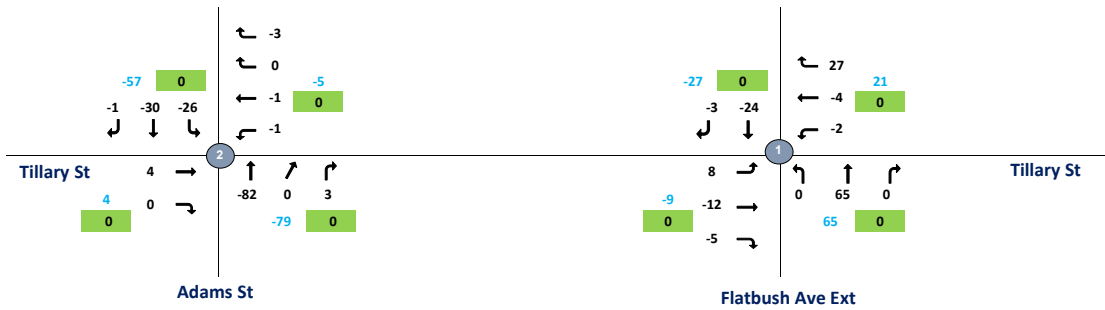

CBD Tolling
Dumbo #2 - Traffic Flowmap
MD No-Action Increment



- Legend:**
- 1 - Intersection (2019 Collected Data)
 - 7 - Intersection (Uncollected Data)
 - 100 - ATR Volume
 - 100 - Approach Volume

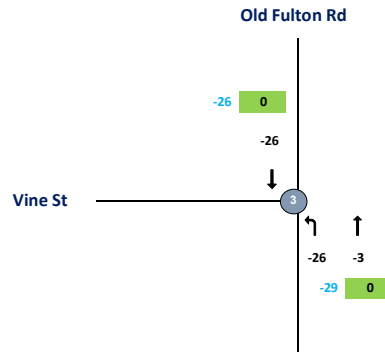

DUMBO

1:00:00 PM

Intersection	Node	Approach	Total Vehicles					Total
			Inbound/Outbound					
			MD Peak Hour					
			L2	L	T	R	R2	
Tillary St & Flatbush Ave ext 2019 (TMC-007)	1							
Tillary St	1	EB	0	8	-12	-5	0	
Tillary St	1	WB	0	-2	-4	27	0	
Flatbush Ave ext	1	NB	0	0	65	0	0	
Flatbush Ave ext	1	SB	0	0	-24	-3	0	50
Tillary St & Adams St 2019 (TMC-008)	2							
Tillary St	2	EB	0	0	4	0	0	
Tillary St	2	WB	0	-1	-1	0	-3	
Adams St	2	NB	0	0	-82	0	3	
Adams St	2	SB	0	-26	-30	-1	0	-137
Vine St & Old Fulton Rd 2019 (TMC-009)	3							
Vine St	3	EB	0	0	0	0	0	
Vine St	3	WB	0	0	0	0	0	
Old Fulton Rd	3	NB	0	-26	-3	0	0	
Old Fulton Rd	3	SB	0	0	-26	0	0	-55

CBD Tolling
Dumbo - Traffic Flowmap
PM No-Action Increment



- Legend:**
- 1 - Intersection (2019 Collected Data)
 - 7 - Intersection (Uncollected Data)
 - 100 - ATR Volume
 - 100 - Approach Volume

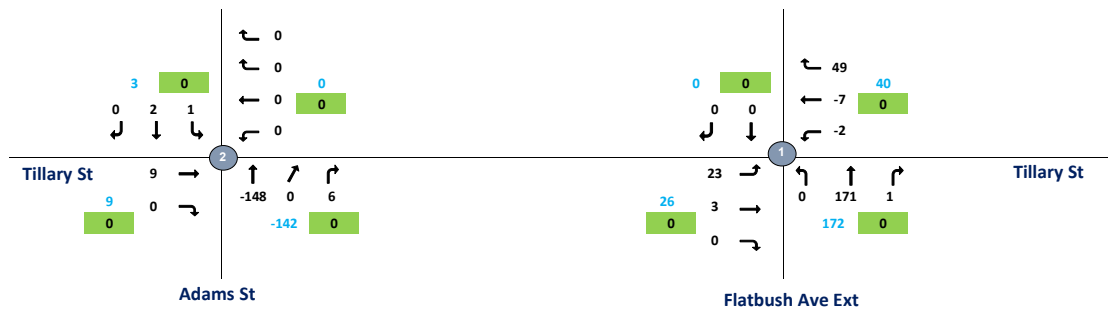

CBD Tolling
Dumbo #2 - Traffic Flowmap
PM No-Action Increment



- Legend:**
- 1 - Intersection (2019 Collected Data)
 - 7 - Intersection (Uncollected Data)
 - ATR Volume
 - Approach Volume

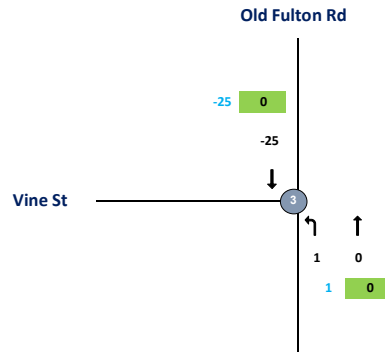

DUMBO

5:00:00 PM

Intersection	Node	Approach	Total Vehicles					
			Inbound/Outbound					
			PM Peak Hour					
			L2	L	T	R	R2	Total
Tillary St & Flatbush Ave ext 2019 (TMC-007)	1							
Tillary St	1	EB	0	23	3	0	0	
Tillary St	1	WB	0	-2	-7	49	0	
Flatbush Ave ext	1	NB	0	0	171	1	0	
Flatbush Ave ext	1	SB	0	0	0	0	0	238
Tillary St & Adams St 2019 (TMC-008)	2							
Tillary St	2	EB	0	0	9	0	0	
Tillary St	2	WB	0	0	0	0	0	
Adams St	2	NB	0	0	-148	0	6	
Adams St	2	SB	0	1	2	0	0	-130
Vine St & Old Fulton Rd 2019 (TMC-009)	3							
Vine St	3	EB	0	0	0	0	0	
Vine St	3	WB	0	0	0	0	0	
Old Fulton Rd	3	NB	0	1	0	0	0	
Old Fulton Rd	3	SB	0	0	-25	0	0	-24

CBD Tolling
Dumbo - Traffic Flowmap
LN No-Action Increment



- Legend:**
- 1 - Intersection (2019 Collected Data)
 - 7 - Intersection (Uncollected Data)
 - 100 - ATR Volume
 - 100 - Approach Volume

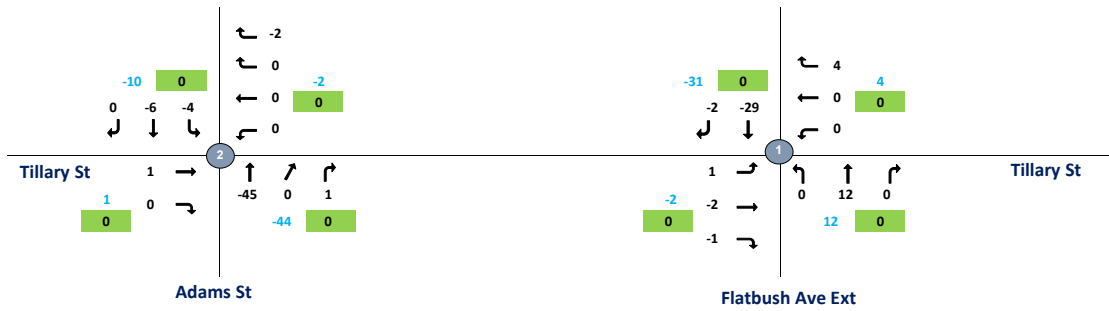

CBD Tolling
Dumbo #2 - Traffic Flowmap
LN No-Action Increment



- Legend:**
- 1 - Intersection (2019 Collected Data)
 - 7 - Intersection (Uncollected Data)
 - 100 - ATR Volume
 - 100 - Approach Volume

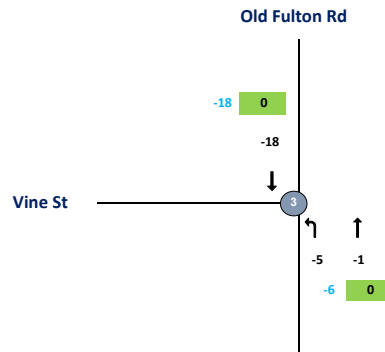

DUMBO

9:00:00 PM

Intersection	Node	Approach	Total Vehicles					
			Inbound/Outbound					
			LN Peak Hour					
			L2	L	T	R	R2	Total
Tillary St & Flatbush Ave ext 2019 (TMC-007)	1							
Tillary St	1	EB	0	1	-2	-1	0	
Tillary St	1	WB	0	0	0	4	0	
Flatbush Ave ext	1	NB	0	0	12	0	0	
Flatbush Ave ext	1	SB	0	0	-29	-2	0	-17
Tillary St & Adams St 2019 (TMC-008)	2							
Tillary St	2	EB	0	0	1	0	0	
Tillary St	2	WB	0	0	0	0	-2	
Adams St	2	NB	0	0	-45	0	1	
Adams St	2	SB	0	-4	-6	0	0	-55
Vine St & Old Fulton Rd 2019 (TMC-009)	3							
Vine St	3	EB	0	0	0	0	0	
Vine St	3	WB	0	0	0	0	0	
Old Fulton Rd	3	NB	0	-5	-1	0	0	
Old Fulton Rd	3	SB	0	0	-18	0	0	-24

CBD Tolling
LIC - Traffic Flowmap #2
AM No-Action Increment



- Legend:**
- Intersection (2019 Collected Data)
 - Intersection (Uncollected Data)
 - 100 - ATR Volume
 - 100 - Approach Volume

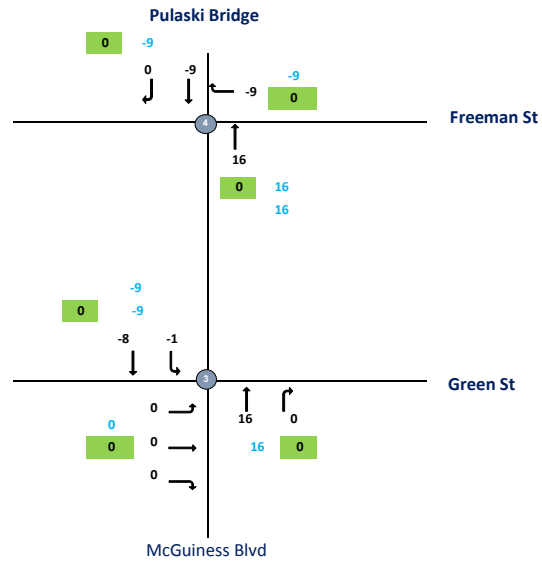

CBD Tolling
LIC - Traffic Flowmap #3
AM No-Action Increment



- Legend:**
- Intersection (2019 Collected Data)
 - Intersection (Uncollected Data)
 - 100 - ATR Volume
 - 100 - Approach Volume

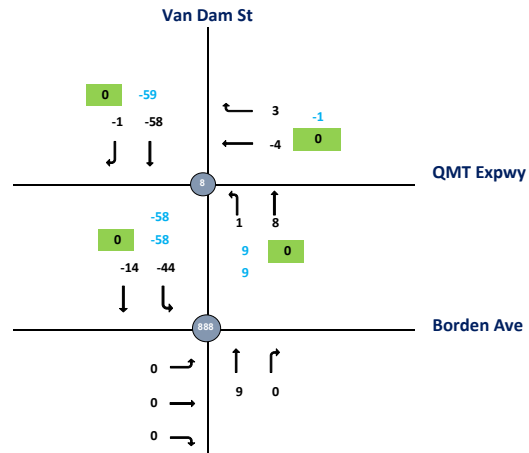

CBD Tolling
LIC - Traffic Flowmap #4
AM No-Action Increment



- Legend:**
- 1 - Intersection (2019 Collected Data)
 - 7 - Intersection (Uncollected Data)
 - 100 - ATR Volume
 - 100 - Approach Volume

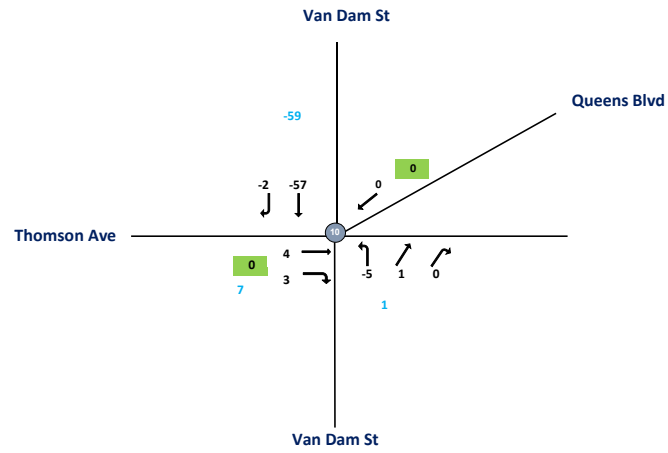
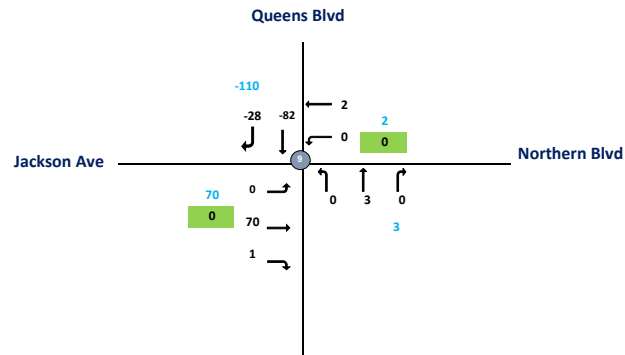

CBD Tolling
LIC - Traffic Flowmap #5
AM No-Action Increment



- Legend:**
- Intersection (2019 Collected Data)
 - Intersection (Uncollected Data)
 - ATR Volume
 - Approach Volume

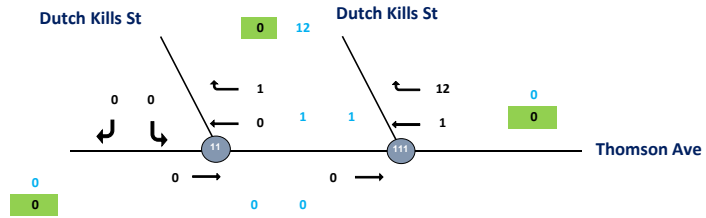

CBD Tolling
LIC - Traffic Flowmap #6
AM No-Action Increment



- Legend:**
- Intersection (2019 Collected Data)
 - Intersection (Uncollected Data)
 - 100 - ATR Volume
 - 100 - Approach Volume

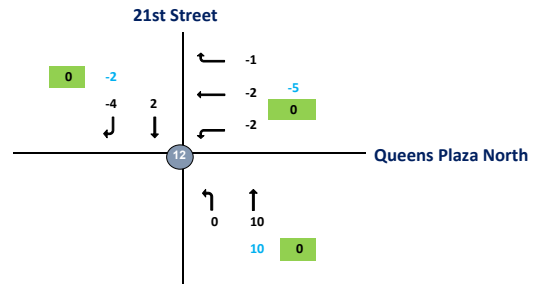

Intersection	Node	Approach	Total Vehicles						
			Inbound/Outbound						
			AM Peak Hour						
			L2	L	T	R	R2	Total	
11th St / Pulaski Bridge & Jackson Ave 2017 --> 2019 (LIC_1_TMC-6A)	1								
Pulaski Bridge / 11th St	1	EB	0	0	16	0	0		
Pulaski Bridge / 11th St	1	WB	0	-10	-4	0	0		
Jackson Ave	1	NB	0	1	0	5	0		
Jackson Ave	1	SB	0	0	0	0	0		8
11th St / 48th St 2017 --> 2019 (LIC_1_TMC-6A)	111								
11th St	111	EB	0	0	0	0	0		
11th St	111	WB	0	0	0	0	0		
48th St	111	NB	0	0	0	0	0		
48th St	111	SB	0	0	0	0	0		0
Vernon Blvd & 50th Ave 2019 (TMC-001)	2								
50th Ave	2	EB	0	0	0	0	0		
50th Ave	2	WB	0	0	0	0	0		
Vernon Blvd	2	NB	0	0	13	1	0		
Vernon Blvd	2	SB	0	0	0	0	0		14
Pulsaki Bridge & Green St 2019 (TMC-002)	3								
Green St	3	EB	0	0	0	0	0		
Green St	3	WB	0	0	0	0	0		
Pulsaki Bridge	3	NB	0	0	16	0	0		
Pulsaki Bridge	3	SB	0	-1	-8	0	0		7
Pulsaki Bridge & Freeman St 2019 (TMC-003)	4								
Freeman St	4	EB	0	0	0	0	0		
Freeman St	4	WB	0	0	0	-9	0		
Pulsaki Bridge	4	NB	0	0	16	0	0		
Pulsaki Bridge	4	SB	0	0	-9	0	0		-2
49th Ave & 21st St 2017 --> 2019 (LIC_5_TMC-6C)	5								
49th Ave	5	EB	0	3	11	1	0		
49th Ave	5	WB	0	0	0	0	0		
21th Ave	5	NB	0	0	0	0	0		
21th Ave	5	SB	0	-1	-1	0	0		13
Borden Ave & 11th Street 2018 -- 2019 (LIC_7_TMC-6D)	7								
Borden Ave	7	EB	0	1	0	1	0		
Borden Ave	7	WB	0	0	2	2	0		
11th St	7	NB	0	2	7	3	0		
11th St	7	SB	0	10	0	35	0		63

Van Dam St & QMT Expwy (North) 2019 (TMC-004A)	8								
QMT Expwy	8	EB	0	0	0	0	0		
QMT Expwy	8	WB	0	0	-4	3	0		
Van Dam St	8	NB	0	1	8	0	0		
Van Dam St	8	SB	0	0	-58	-1	0		-51
Van Dam St & QMT Expwy (South) 2019 (TMC-004B)	888								
QMT Expwy	888	EB	0	0	0	0	0		
QMT Expwy	888	WB	0	0	0	0	0		
Van Dam St	888	NB	0	0	9	0	0		
Van Dam St	888	SB	0	-44	-14	0	0		-49
Queens Blvd & Jackson Ave (Mainline) 2018 --> 2019 (LIC_9A_TMC-6E)	9								
Queens Blvd	9	EB	0	0	-82	-28	0		
Queens Blvd	9	WB	0	0	3	0	0		
Jackson Ave	9	NB	0	0	70	1	0		
Jackson Ave	9	SB	0	0	2	0	0		-34
Queens Blvd & Jackson Ave (Service Rd) 2018 --> 2019 (LIC_9A_TMC-6E)	9A								
Queens Blvd	9A	EB	0	0	0	0	0		
Queens Blvd	9A	WB	0	0	0	0	0		
Jackson Ave	9A	NB	0	0	0	0	0		
Jackson Ave	9A	SB	0	0	0	0	0		0
Thompson Ave & Queens Blvd 2018 --> 2019 (LIC_10_TMC-6G)	10								
Queens Blvd	10	EB	0	0	0	4	3		
Queens Blvd	10	WB	0	0	0	0	0		
Thompson Ave	10	NB	0	-5	1	0	0		
Thompson Ave	10	SB	0	0	-57	-2	0		-56
Dutch Kills St & Thomson Ave (#1) 2019 (TMC-005)	11								
Thomson Ave	11	EB	0	0	0	0	0		
Thomson Ave	11	WB	0	0	0	1	0		
Dutch Kills St	11	NB	0	0	0	0	0		
Dutch Kills St	11	SB	0	0	0	0	0		1
Dutch Kills St & Thomson Ave (#2) 2019 (TMC-005)	1111								
Thomson Ave	1111	EB	0	0	0	0	0		
Thomson Ave	1111	WB	0	0	1	12	0		
Dutch Kills St	1111	NB	0	0	0	0	0		
Dutch Kills St	1111	SB	0	0	0	0	0		13
21st Street & Queens Plaza North 2019 (TMC-006)	12								
Queens Plaza North	12	EB	0	0	0	0	0		
Queens Plaza North	12	WB	0	-2	-2	-1	0		
21st Street	12	NB	0	0	10	0	0		
21st Street	12	SB	0	0	2	-4	0		3

CBD Tolling
LIC - Traffic Flowmap #2
MD No-Action Increment



- Legend:**
- Intersection (2019 Collected Data)
 - Intersection (Uncollected Data)
 - 100 - ATR Volume
 - 100 - Approach Volume

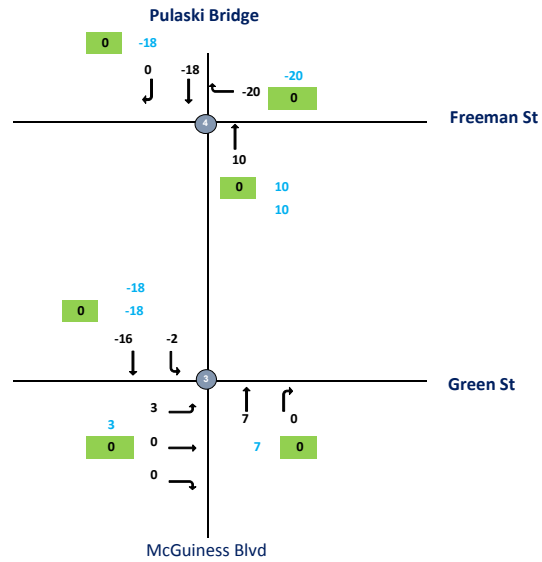

CBD Tolling
LIC - Traffic Flowmap #3
MD No-Action Increment



- Legend:**
- Intersection (2019 Collected Data)
 - Intersection (Uncollected Data)
 - 100 - ATR Volume
 - 100 - Approach Volume

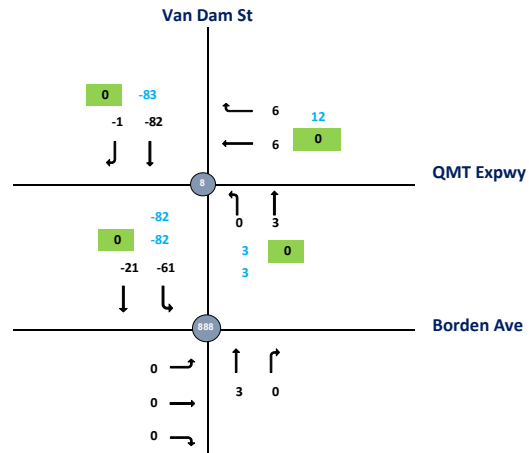

CBD Tolling
LIC - Traffic Flowmap #4
MD No-Action Increment



- Legend:**
- 1 - Intersection (2019 Collected Data)
 - 7 - Intersection (Uncollected Data)
 - 100 - ATR Volume
 - 100 - Approach Volume

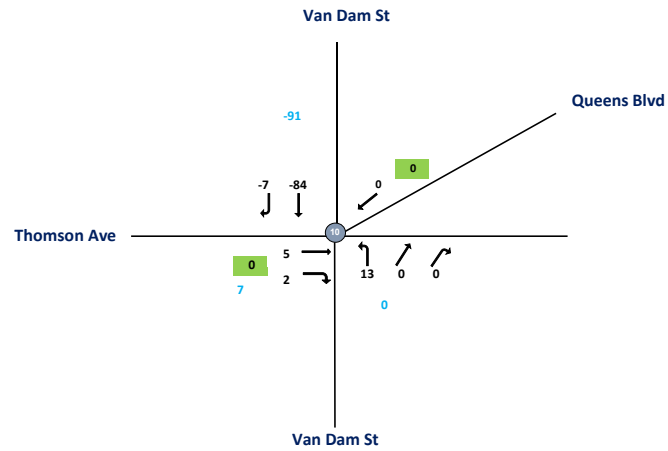
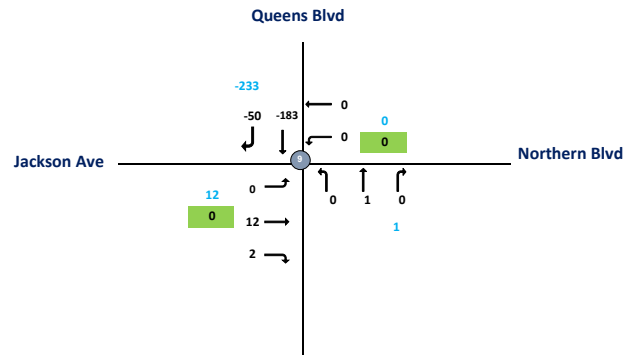

CBD Tolling
LIC - Traffic Flowmap #5
MD No-Action Increment



- Legend:**
- Intersection (2019 Collected Data)
 - Intersection (Uncollected Data)
 - 100 - ATR Volume
 - 100 - Approach Volume

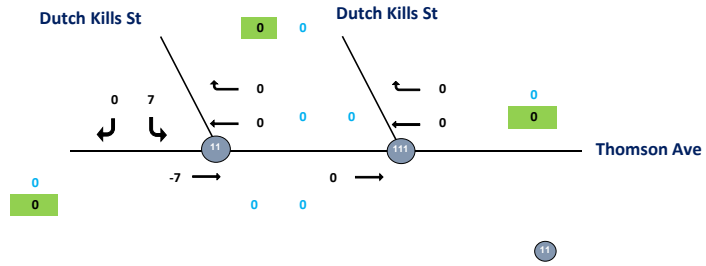

CBD Tolling
LIC - Traffic Flowmap #6
MD No-Action Increment



- Legend:**
- Intersection (2019 Collected Data)
 - Intersection (Uncollected Data)
 - 100 - ATR Volume
 - 100 - Approach Volume

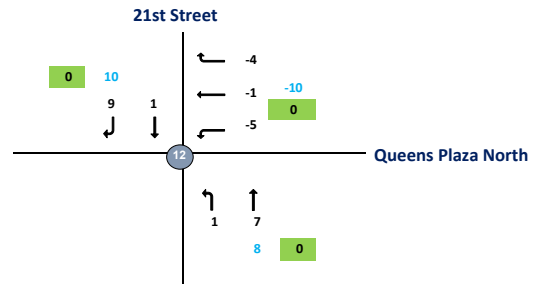

Intersection	Node	Approach	Total Vehicles						
			Inbound/Outbound						
			MD Peak Hour						
			L2	L	T	R	R2	Total	
11th St / Pulaski Brdge & Jackson Ave 2017 --> 2019 (LIC_1_TMC-6A)	1								
Pulaski Bridge / 11th St	1	EB	0	0	14	0	0		
Pulaski Bridge / 11th St	1	WB	0	-15	-7	0	0		
Jackson Ave	1	NB	0	0	0	3	0		
Jackson Ave	1	SB	0	0	0	0	0		-5
11th St / 48th St 2017 --> 2019 (LIC_1_TMC-6A)	111								
11th St	111	EB	0	0	0	0	0		
11th St	111	WB	0	0	0	0	0		
48th St	111	NB	0	0	0	0	0		
48th St	111	SB	0	0	0	0	0		0
Vernon Blvd & 50th Ave 2019 (TMC-001)	2								
50th Ave	2	EB	0	0	0	0	0		
50th Ave	2	WB	0	0	0	0	0		
Vernon Blvd	2	NB	0	0	10	2	0		
Vernon Blvd	2	SB	0	0	-1	0	0		11
Pulsaki Bridge & Green St 2019 (TMC-002)	3								
Green St	3	EB	0	3	0	0	0		
Green St	3	WB	0	0	0	0	0		
Pulsaki Bridge	3	NB	0	0	7	0	0		
Pulsaki Btridge	3	SB	0	-2	-16	0	0		-8
Pulsaki Bridge & Freeman St 2019 (TMC-003)	4								
Freeman St	4	EB	0	0	0	0	0		
Freeman St	4	WB	0	0	0	-20	0		
Pulsaki Bridge	4	NB	0	0	10	0	0		
Pulsaki Btridge	4	SB	0	0	-18	0	0		-28
49th Ave & 21st St 2017 --> 2019 (LIC_5_TMC-6C)	5								
49th Ave	5	EB	0	3	11	1	0		
49th Ave	5	WB	0	0	0	0	0		
21th Ave	5	NB	0	0	0	0	0		
21th Ave	5	SB	0	0	0	0	0		15
Borden Ave & 11th Street 2018 -- 2019 (LIC_7_TMC-6D)	7								
Borden Ave	7	EB	0	1	0	1	0		
Borden Ave	7	WB	0	0	1	6	0		
11th St	7	NB	0	0	0	1	0		
11th St	7	SB	0	10	1	30	0		51

Van Dam St & QMT Expwy (North) 2019 (TMC-004A)	8								
QMT Expwy	8	EB	0	0	0	0	0		
QMT Expwy	8	WB	0	0	6	6	0		
Van Dam St	8	NB	0	0	3	0	0		
Van Dam St	8	SB	0	0	-82	-1	0		-68
Van Dam St & QMT Expwy (South) 2019 (TMC-004B)	888								
QMT Expwy	888	EB	0	0	0	0	0		
QMT Expwy	888	WB	0	0	0	0	0		
Van Dam St	888	NB	0	0	3	0	0		
Van Dam St	888	SB	0	-61	-21	0	0		-79
Queens Blvd & Jackson Ave (Mainline) 2018 --> 2019 (LIC_9A_TMC-6E)	9								
Queens Blvd	9	EB	0	0	-183	-50	0		
Queens Blvd	9	WB	0	0	1	0	0		
Jackson Ave	9	NB	0	0	12	2	0		
Jackson Ave	9	SB	0	0	0	0	0		-218
Queens Blvd & Jackson Ave (Service Rd) 2018 --> 2019 (LIC_9A_TMC-6E)	9A								
Queens Blvd	9A	EB	0	0	0	0	0		
Queens Blvd	9A	WB	0	0	0	0	0		
Jackson Ave	9A	NB	0	0	0	0	0		
Jackson Ave	9A	SB	0	0	0	0	0		0
Thompson Ave & Queens Blvd 2018 --> 2019 (LIC_10_TMC-6G)	10								
Queens Blvd	10	EB	0	0	0	5	2		
Queens Blvd	10	WB	0	0	0	0	0		
Thompson Ave	10	NB	0	13	0	0	0		
Thompson Ave	10	SB	0	0	-84	-7	0		-71
Dutch Kills St & Thomson Ave (#1) 2019 (TMC-005)	11								
Thomson Ave	11	EB	0	0	-7	0	0		
Thomson Ave	11	WB	0	0	0	0	0		
Dutch Kills St	11	NB	0	0	0	0	0		
Dutch Kills St	11	SB	0	7	0	0	0		0
Dutch Kills St & Thomson Ave (#2) 2019 (TMC-005)	1111								
Thomson Ave	1111	EB	0	0	0	0	0		
Thomson Ave	1111	WB	0	0	0	0	0		
Dutch Kills St	1111	NB	0	0	0	0	0		
Dutch Kills St	1111	SB	0	0	0	0	0		0
21st Street & Queens Plaza North 2019 (TMC-006)	12								
Queens Plaza North	12	EB	0	0	0	0	0		
Queens Plaza North	12	WB	0	-5	-1	-4	0		
21st Street	12	NB	0	1	7	0	0		
21st Street	12	SB	0	0	1	9	0		8

CBD Tolling
LIC - Traffic Flowmap #1
PM Action Increment



- Legend:**
- 1 - Intersection (2019 Collected Data)
 - 7 - Intersection (Uncollected Data)
 - 100 - ATR Volume
 - 100 - Approach Volume

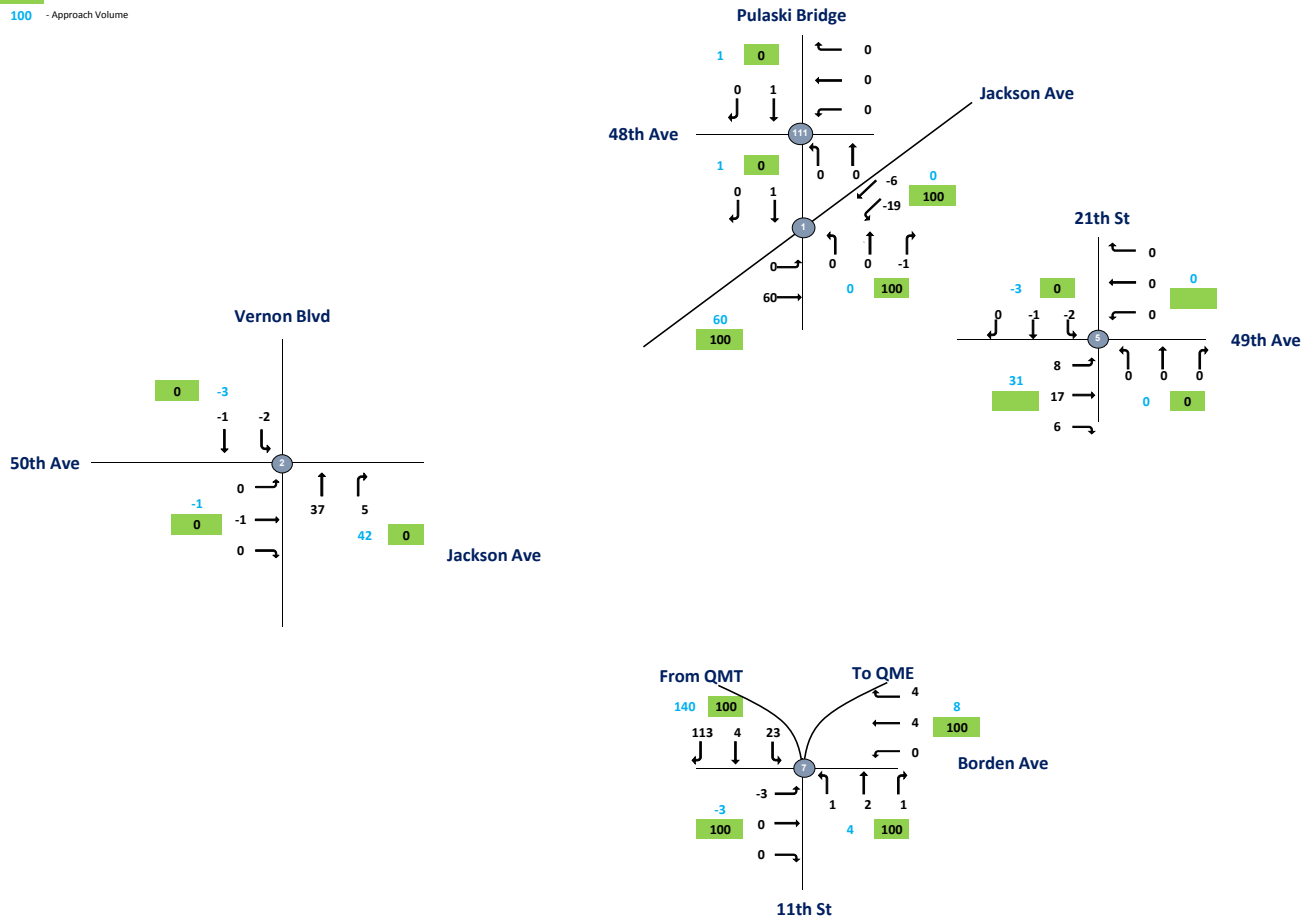

CBD Tolling
LIC - Traffic Flowmap #2
PM Action Increment



- Legend:**
- Intersection (2019 Collected Data)
 - 7 - Intersection (Uncollected Data)
 - 100 - ATR Volume
 - 100 - Approach Volume

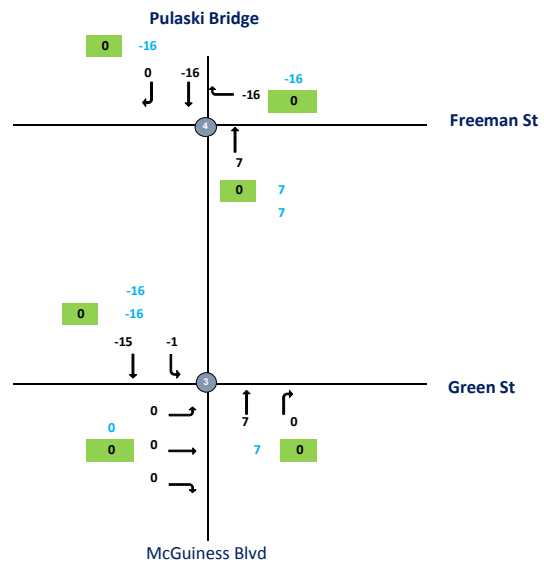

CBD Tolling
LIC - Traffic Flowmap #3
PM Action Increment



- Legend:**
- Intersection (2019 Collected Data)
 - Intersection (Uncollected Data)
 - 100 - ATR Volume
 - 100 - Approach Volume

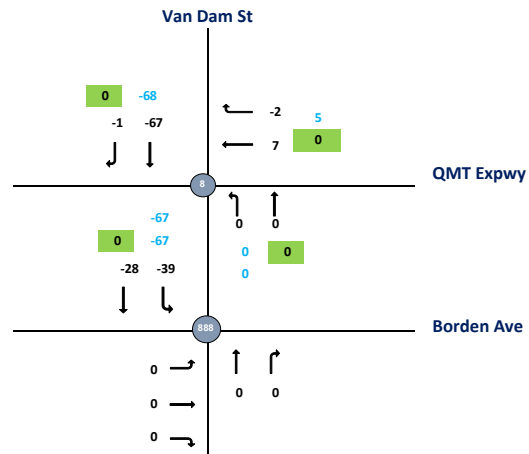

CBD Tolling
LIC - Traffic Flowmap #4
PM Action Increment



- Legend:**
- 1 - Intersection (2019 Collected Data)
 - 7 - Intersection (Uncollected Data)
 - 100 - ATR Volume
 - 100 - Approach Volume

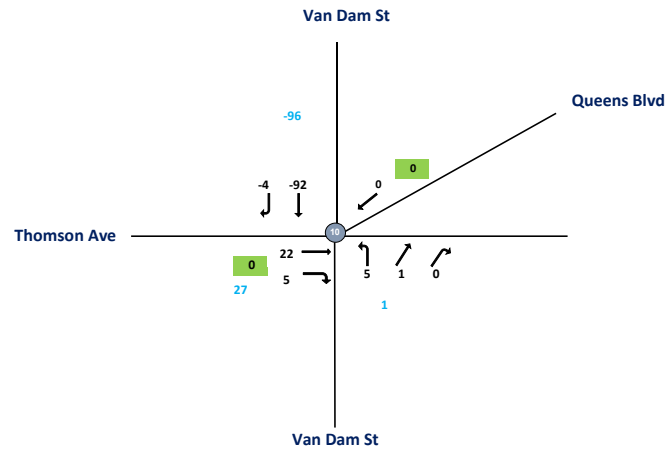
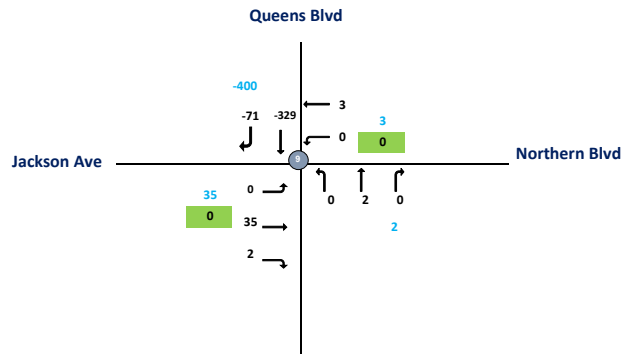

CBD Tolling
LIC - Traffic Flowmap #5
PM Action Increment



- Legend:**
- Intersection (2019 Collected Data)
 - Intersection (Uncollected Data)
 - 100** - ATR Volume
 - 100 - Approach Volume

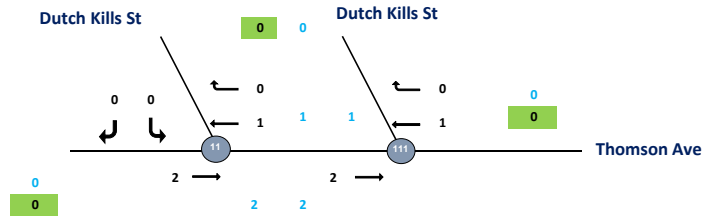

CBD Tolling
LIC - Traffic Flowmap #6
PM Action Increment



- Legend:**
- Intersection (2019 Collected Data)
 - Intersection (Uncollected Data)
 - 100 - ATR Volume
 - 100 - Approach Volume

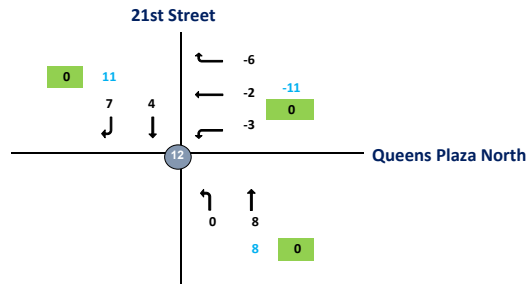

Intersection	Node	Approach	Total Vehicles						
			Inbound/Outbound					Total	
			PM Peak Hour						
			L2	L	T	R	R2		
11th St / Pulaski Brdge & Jackson Ave 2017 --> 2019 (LIC_1_TMC-6A)	1								
Pulaski Bridge / 11th St	1	EB	0	54	92	0	0		
Pulaski Bridge / 11th St	1	WB	0	-45	1	0	0		
Jackson Ave	1	NB	0	0	-45	-1	0		
Jackson Ave	1	SB	0	0	-10	3	0		49
11th St / 48th St 2017 --> 2019 (LIC_1_TMC-6A)	111								
11th St	111	EB	0	0	0	0	0		
11th St	111	WB	0	0	0	0	0		
48th St	111	NB	0	0	9	0	0		
48th St	111	SB	0	0	-7	0	0		2
Vernon Blvd & 50th Ave 2019 (TMC-001)	2								
50th Ave	2	EB	0	0	7	0	0		
50th Ave	2	WB	0	0	0	0	0		
Vernon Blvd	2	NB	0	0	61	18	0		
Vernon Blvd	2	SB	0	8	-3	0	0		91
Pulsaki Bridge & Green St 2019 (TMC-002)	3								
Green St	3	EB	0	-10	0	-2	0		
Green St	3	WB	0	0	0	0	0		
Pulsaki Bridge	3	NB	0	0	-63	0	0		
Pulsaki Btridge	3	SB	0	-2	-56	0	0		-133
Pulsaki Bridge & Freeman St 2019 (TMC-003)	4								
Freeman St	4	EB	0	0	0	0	0		
Freeman St	4	WB	0	0	0	-38	0		
Pulsaki Bridge	4	NB	0	0	-73	0	0		
Pulsaki Btridge	4	SB	0	0	-58	0	0		-169
49th Ave & 21st St 2017 --> 2019 (LIC_5_TMC-6C)	5								
49th Ave	5	EB	0	13	26	10	0		
49th Ave	5	WB	0	0	0	0	0		
21th Ave	5	NB	0	0	0	0	0		
21th Ave	5	SB	0	-4	-2	-1	0		42
Borden Ave & 11th Street 2018 -- 2019 (LIC_7_TMC-6D)	7								
Borden Ave	7	EB	0	23	-5	-5	0		
Borden Ave	7	WB	0	0	-21	-66	0		
11th St	7	NB	0	-2	-3	-10	0		
11th St	7	SB	0	37	6	187	0		141

Van Dam St & QMT Expwy (North) 2019 (TMC-004A)	8								
QMT Expwy	8	EB	0	0	0	0	0		
QMT Expwy	8	WB	0	0	-59	-37	0		
Van Dam St	8	NB	0	-4	-22	0	0		
Van Dam St	8	SB	0	0	-96	-2	0		-220
Van Dam St & QMT Expwy (South) 2019 (TMC-004B)	888								
QMT Expwy	888	EB	0	-2	0	0	0		
QMT Expwy	888	WB	0	0	0	0	0		
Van Dam St	888	NB	0	0	-24	0	0		
Van Dam St	888	SB	0	-56	-40	0	0		-122
Queens Blvd & Jackson Ave (Mainline) 2018 --> 2019 (LIC_9A_TMC-6E)	9								
Queens Blvd	9	EB	0	0	-461	-99	0		
Queens Blvd	9	WB	0	0	-14	0	0		
Jackson Ave	9	NB	0	0	-105	4	0		
Jackson Ave	9	SB	0	0	1	0	0		-674
Queens Blvd & Jackson Ave (Service Rd) 2018 --> 2019 (LIC_9A_TMC-6E)	9A								
Queens Blvd	9A	EB	0	0	0	0	0		
Queens Blvd	9A	WB	0	0	0	0	0		
Jackson Ave	9A	NB	0	0	0	0	0		
Jackson Ave	9A	SB	0	0	0	0	0		0
Thompson Ave & Queens Blvd 2018 --> 2019 (LIC_10_TMC-6G)	10								
Queens Blvd	10	EB	0	0	0	37	8		
Queens Blvd	10	WB	0	0	0	0	0		
Thompson Ave	10	NB	0	-166	-1	0	0		
Thompson Ave	10	SB	0	0	-142	-6	0		-270
Dutch Kills St & Thomson Ave (#1) 2019 (TMC-005)	11								
Thomson Ave	11	EB	0	0	13	0	0		
Thomson Ave	11	WB	0	0	-1	0	0		
Dutch Kills St	11	NB	0	0	0	0	0		
Dutch Kills St	11	SB	0	-11	0	0	0		1
Dutch Kills St & Thomson Ave (#2) 2019 (TMC-005)	1111								
Thomson Ave	1111	EB	0	0	2	0	0		
Thomson Ave	1111	WB	0	0	-1	0	0		
Dutch Kills St	1111	NB	0	0	0	0	0		
Dutch Kills St	1111	SB	0	0	0	0	0		1
21st Street & Queens Plaza North 2019 (TMC-006)	12								
Queens Plaza North	12	EB	0	0	0	0	0		
Queens Plaza North	12	WB	0	-4	-26	-8	0		
21st Street	12	NB	0	0	-18	0	0		
21st Street	12	SB	0	0	2	-46	0		-100

CBD Tolling
LM - Traffic Flowmap #1
AM No-Action Increment



- Legend:**
- 1 - Intersection (2019 Collected Data)
 - 7 - Intersection (Uncollected Data)
 - 100 - ATR Volume
 - 100 - Approach Volume

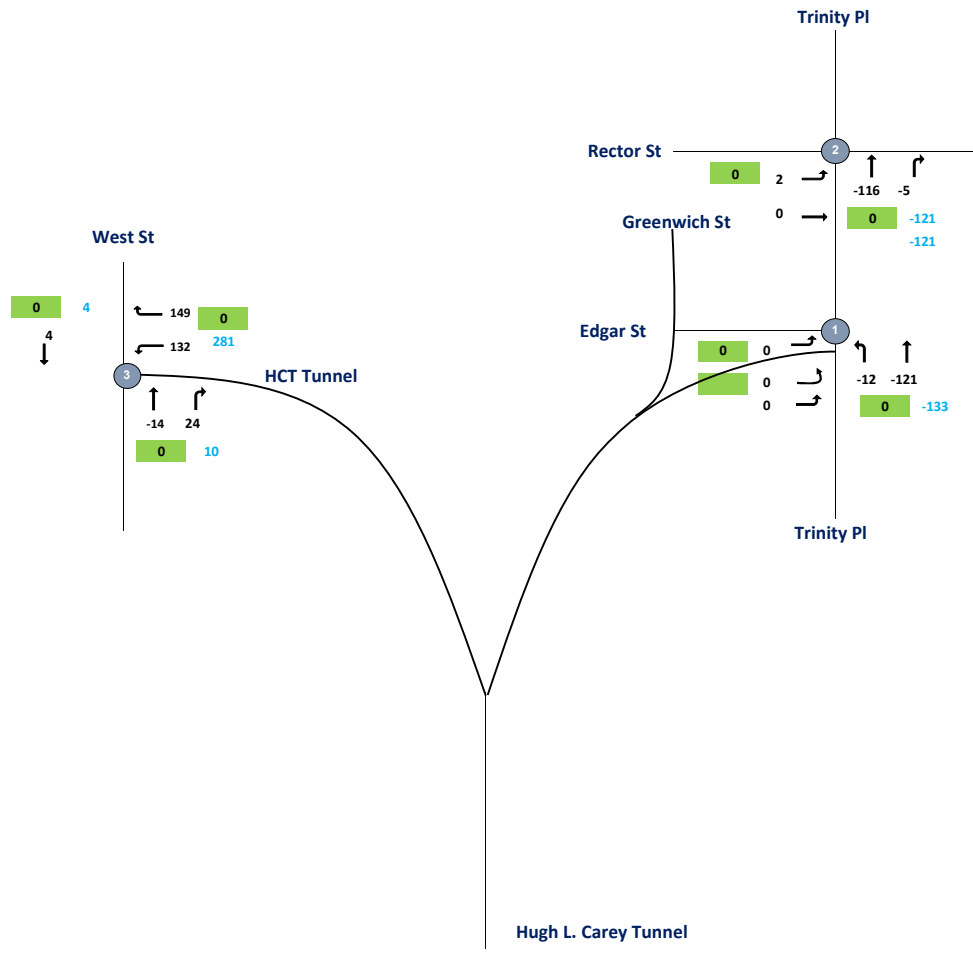

CBD Tolling
LM - Traffic Flowmap #2
AM No-Action Increment

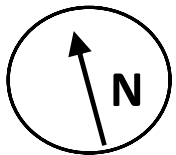

Legend:

1 - Intersection (2019 Collected Data)

7 - Intersection (Uncollected Data)

100 - ATR Volume

100 - Approach Volume

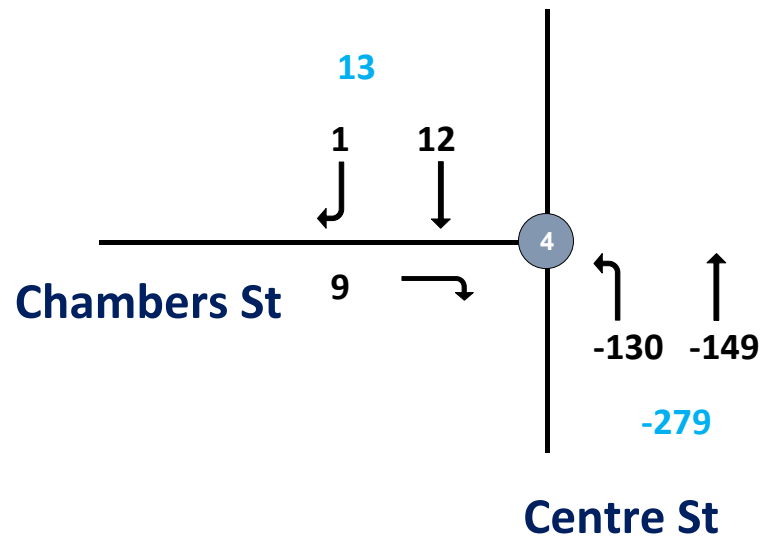

CBD Tolling
LM - Traffic Flowmap #3
AM No-Action Increment



- Legend:**
- Intersection (2019 Collected Data)
 - 7 Intersection (Uncollected Data)
 - 100 - ATR Volume
 - 100 - Approach Volume

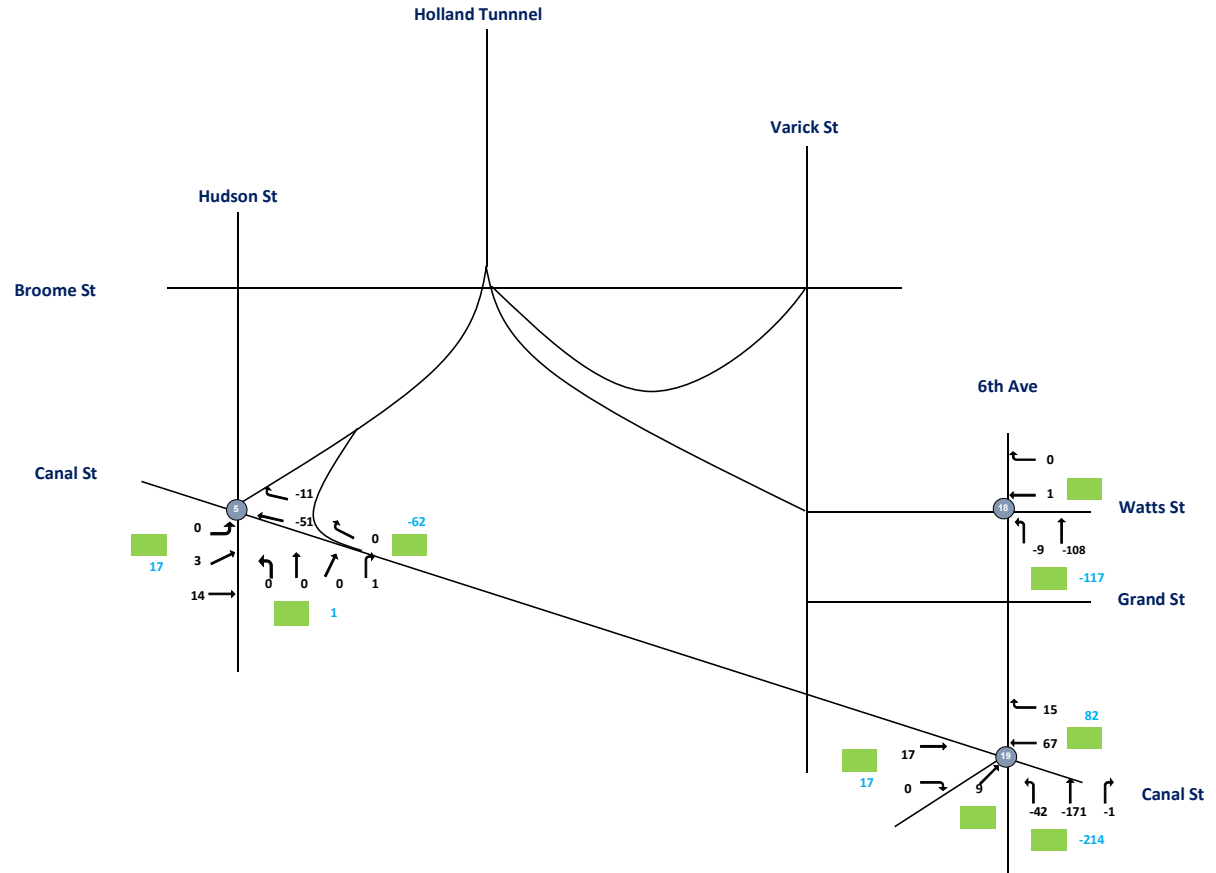

CBD Tolling
LM - Traffic Flowmap #4
AM No-Action Increment



- Legend:**
- Intersection (2019 Collected Data)
 - Intersection (Uncollected Data)
 - ATR Volume
 - Approach Volume

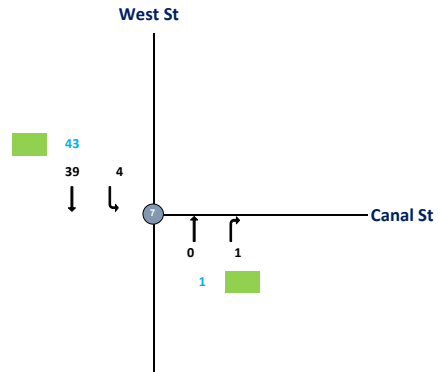

CBD Tolling
LM - Traffic Flowmap #5
AM No-Action Increment



- Legend:**
- 1 - Intersection (2019 Collected Data)
 - 7 - Intersection (Uncollected Data)
 - 100 - ATR Volume
 - 100 - Approach Volume

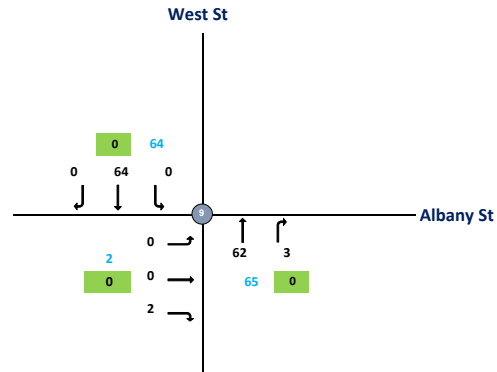

CBD Tolling
LM - Traffic Flowmap #6
AM No-Action Increment



- Legend:**
- 1 - Intersection (2019 Collected Data)
 - 7 - Intersection (Uncollected Data)
 - 100 - ATR Volume
 - 100 - Approach Volume
 - ↶ - Illegal movement

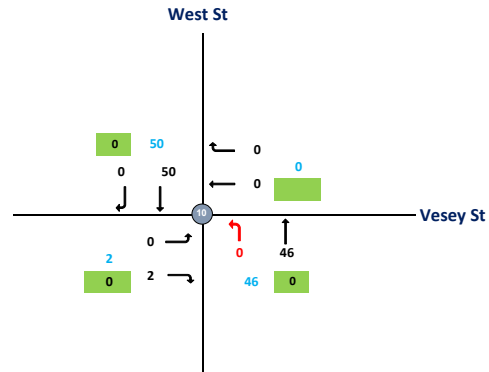

CBD Tolling
LM - Traffic Flowmap #7
AM No-Action Increment



- Legend:**
- 1 - Intersection (2019 Collected Data)
 - 7 - Intersection (Uncollected Data)
 - 100 - ATR Volume
 - 100 - Approach Volume

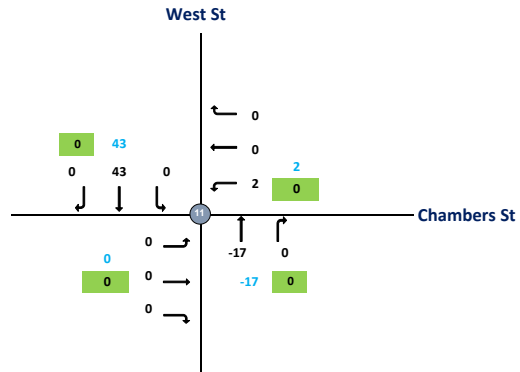

CBD Tolling
LM - Traffic Flowmap #8
AM No-Action Increment



- Legend:**
- Intersection (2019 Collected Data)
 - Intersection (Uncollected Data)
 - ATR Volume
 - Approach Volume

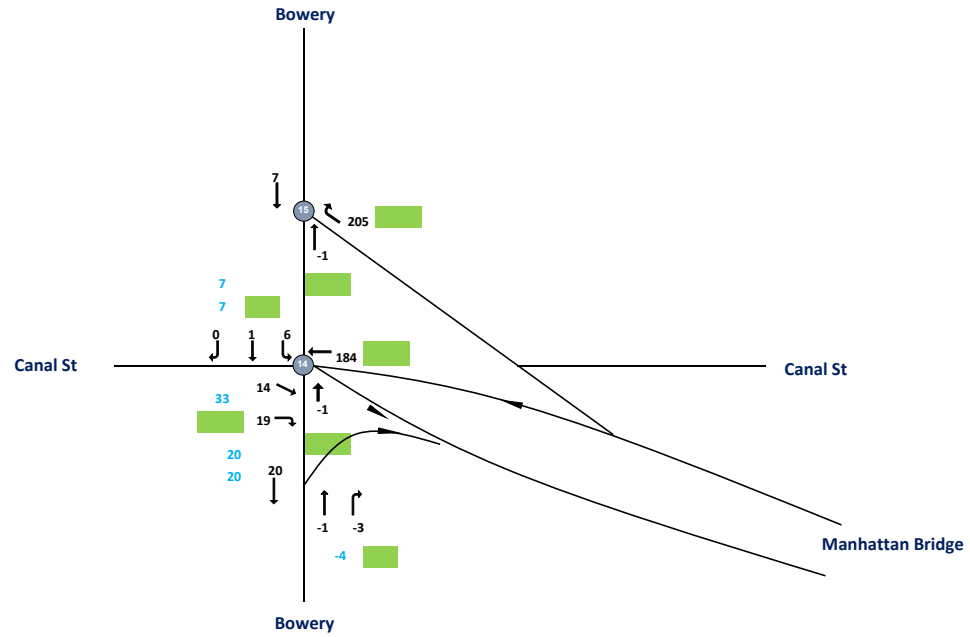

Intersection	Node	Approach	Total Volume					
			Inbound/Outbound					Total
			L2	L	T	R	R2	
Edgar St. and Trinity Pl. 2019 (TMC-010)	1							
Edgar St.	1	EB	0	0	0	0	0	
478 Exit Ramp.	1	NE	0	0	0	0	0	
Trinity Pl.	1	NB	0	-12	-121	0	0	
Trinity Pl.	1	SB	0	0	0	0	0	-133
Rector St. and Trinity Pl. 2019 (TMC-011)	2							
Rector St.	2	EB	0	2	0	0	0	
Rector St.	2	WB	0	0	0	0	0	
Trinity Pl.	2	NB	0	0	-116	-5	0	
Trinity Pl.	2	SB	0	0	0	0	0	-119
West St. and HCT Exit. 2019 (TMC-012)	3							
-	3	EB	0	0	0	0	0	
HCT Exit.	3	WB	0	132	0	0	0	
West St.	3	NB	0	0	-14	0	24	
West St.	3	SB	0	0	4	0	0	146
West St. and HCT Exit. 2019 (TMC-012)	333							
W. Thams St.	333	EB	0	0	0	0	0	
HCT Exit.	333	WB	0	0	0	149	0	
West St.	333	NB	0	0	-14	0	0	
West St.	333	SB	0	0	4	0	0	139
Chambers St. and Centre St. 2018	4							
Chambers St.	4	EB	0	0	0	9	0	
-	4	WB	0	0	0	0	0	
Centre St.	4	NB	0	-130	-149	0	0	
Centre St.	4	SB	0	0	12	1	0	-257
Hudson St. and Canal St. 2018	5							
Canal St.	5	EB	0	3	14	0	0	
Canal St.	5	WB	0	0	-51	-11	0	
Hudson St.	5	NB	0	0	0	0	1	
Hudson St.	5	SB	0	0	0	0	0	-44

Hudson St. and Canal St.								
2018	555							
Canal St.	555	EB	0	0	15	0	0	
Canal St.	555	WB	0	0	-62	0	0	
Hudson St.	555	NB	0	0	0	0	0	
Hudson St.	555	SB	0	0	0	0	0	-47
West St. and Canal St N.								
2018	7							
Canal St N.	7	EB	0	0	0	0	0	
-	7	WB	0	0	0	0	0	
West St.	7	NB	0	0	0	1	0	
West St.	7	SB	0	4	39	0	0	44
West St. and Canal St S.								
2018	777							
-	777	EB	0	0	0	0	0	
Canal St S.	777	WB	0	0	0	0	0	
West St.	777	NB	0	0	0	0	0	
West St.	777	SB	0	0	43	0	0	43
West St. and Albany St.								
2019 (TMC-013)	9							
Albany St.	9	EB	0	0	0	2	0	
-	9	WB	0	0	0	0	0	
West St.	9	NB	0	0	62	3	0	
West St.	9	SB	0	0	64	0	0	131
West St. and Vesey St.								
2019 (TMC-014)	10							
Vesey St.	10	EB	0	0	0	2	0	
Vesey St.	10	WB	0	0	0	0	0	
West St.	10	NB	0	0	46	0	0	
West St.	10	SB	0	0	50	0	0	-133
West St. and Chambers St.								
2019 (TMC-015)	11							
Chambers St.	11	EB	0	0	0	0	0	
Chambers St.	11	WB	0	2	0	0	0	
West St.	11	NB	0	0	-17	0	0	
West St.	11	SB	0	0	43	0	0	28

Bowey and Canal St./Manhattan Bridge Off-Ramp								
2018	14							
Canal St.	14	EB	0	0	14	19	0	
Manhattan Bridge Off-Ramp	14	WB	0	0	184	0	0	
Bowey	14	NB	0	0	-1	-3	0	
Bowey	14	SB	0	6	1	0	0	220
Bowey and Manhattan Bridge Off-Ramp								
2018	15							
	15	EB	0	0	0	0	0	
Manhattan Bridge Off-Ramp	15	WB	0	0	0	205	0	
Bowey	15	NB	0	0	-1	0	0	
Bowey	15	SB	0	0	7	0	0	211
6th Ave. and Watts St								
2018	18							
Watts St	18	EB	0	0	0	0	0	
Watts St	18	WB	0	0	1	0	0	
6th Ave.	18	NB	0	-9	-108	0	0	
6th Ave.	18	SB	0	0	0	0	0	-116
6th Ave. and Canal St.								
2018	19							
Canal St.	19	EB	0	0	17	0	0	
Canal St.	19	WB	0	0	67	15	0	
6th Ave.	19	NB	0	-42	-171	-1	0	
Laight St.	19	NE	0	0	0	9	0	-106

CBD Tolling
LM - Traffic Flowmap #1
MD No-Action Increment



- Legend:**
- 1 - Intersection (2019 Collected Data)
 - 7 - Intersection (Uncollected Data)
 - 100 - ATR Volume
 - 100 - Approach Volume

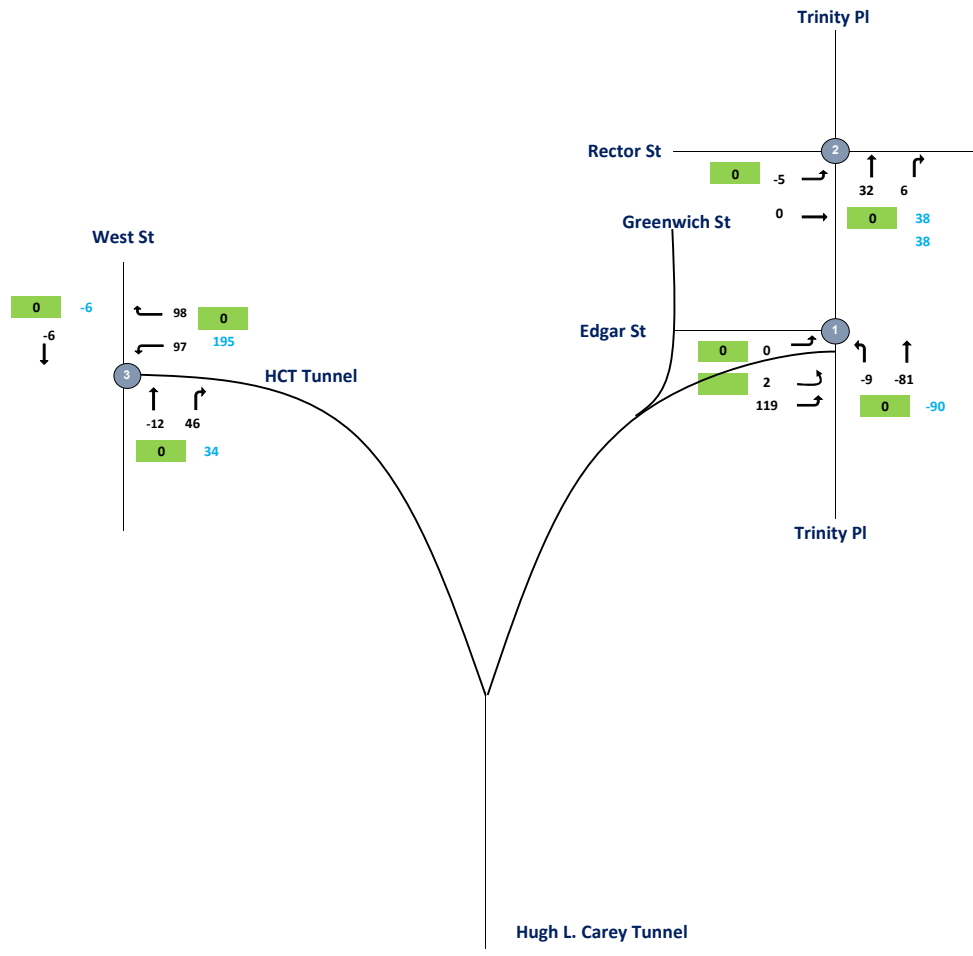

CBD Tolling
LM - Traffic Flowmap #2
MD No-Action Increment

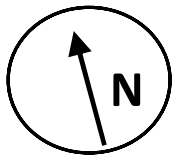

Legend:

- 1 - Intersection (2019 Collected Data)
- 7 - Intersection (Uncollected Data)
- 100 - ATR Volume
- 100 - Approach Volume

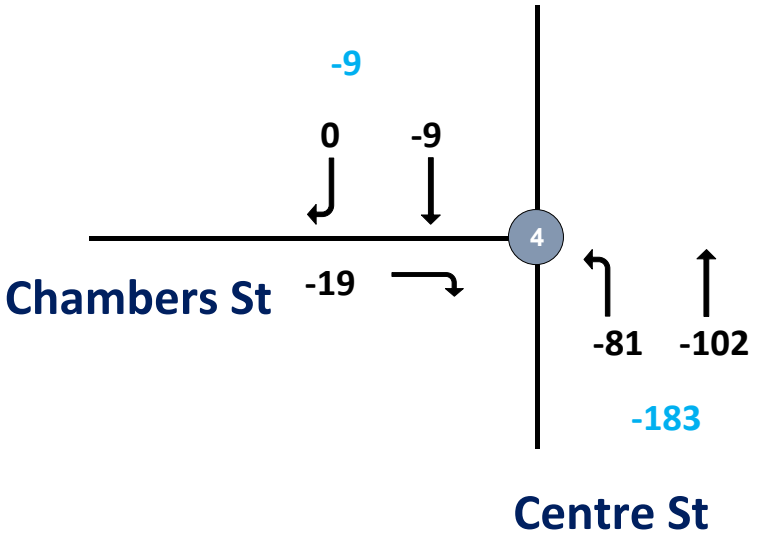

CBD Tolling
LM - Traffic Flowmap #3
MD No-Action Increment



- Legend:**
- Intersection (2019 Collected Data)
 - Intersection (Uncollected Data)
 - 100 - ATR Volume
 - 100 - Approach Volume

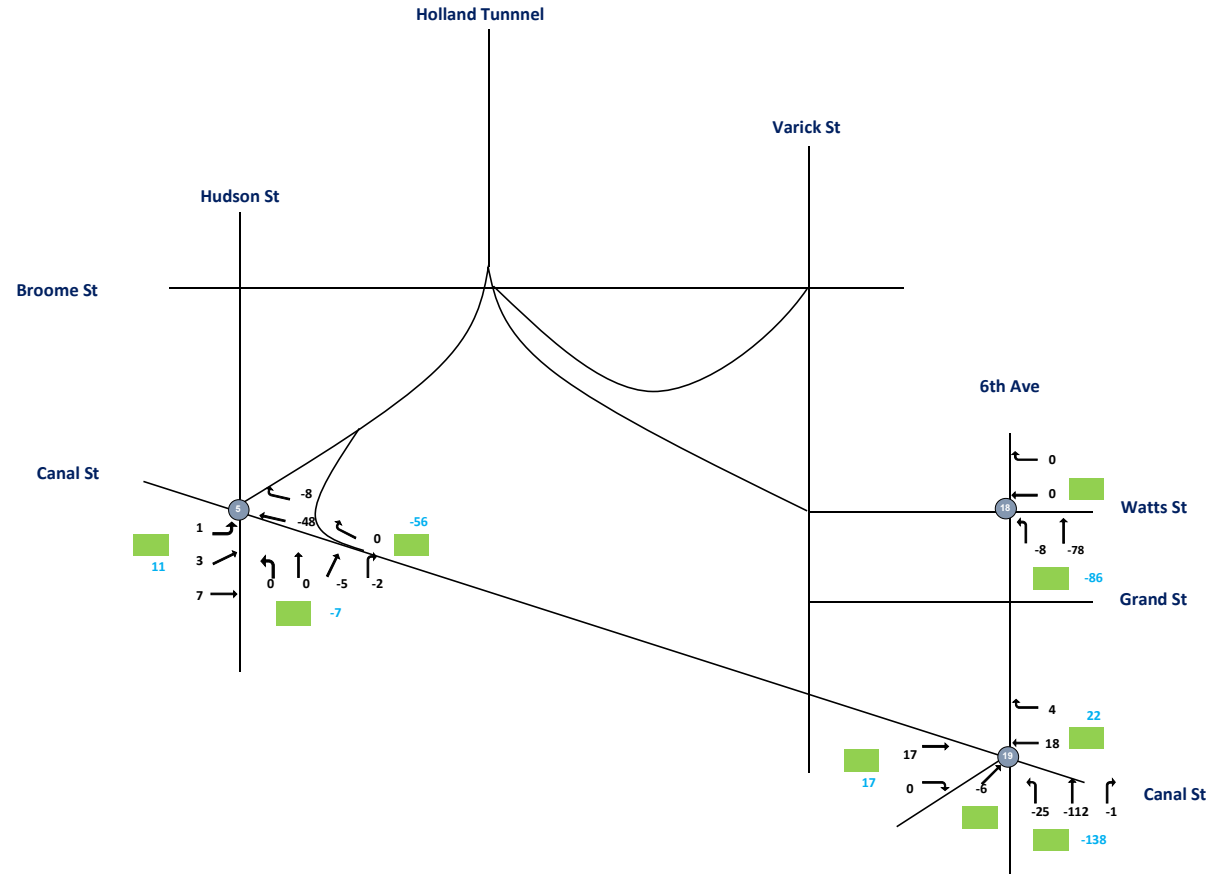

CBD Tolling
LM - Traffic Flowmap #4
MD No-Action Increment



- Legend:**
- Intersection (2019 Collected Data)
 - Intersection (Uncollected Data)
 - ATR Volume
 - Approach Volume

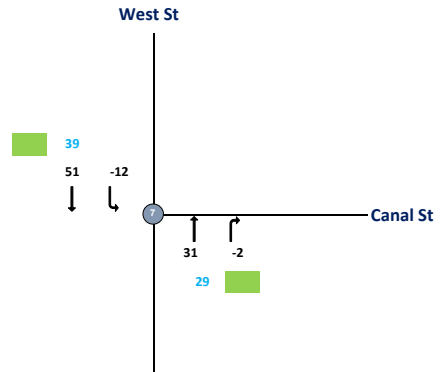

CBD Tolling
LM - Traffic Flowmap #5
MD No-Action Increment



- Legend:**
- 1 - Intersection (2019 Collected Data)
 - 7 - Intersection (Uncollected Data)
 - 100 - ATR Volume
 - 100 - Approach Volume

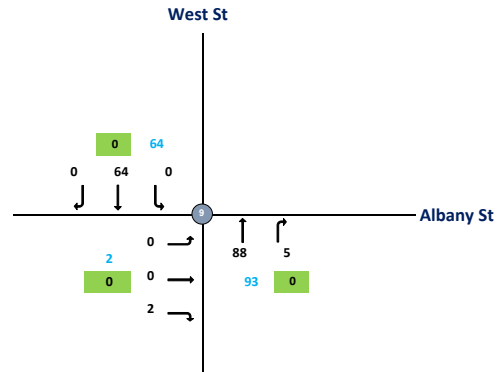

CBD Tolling
LM - Traffic Flowmap #6
MD No-Action Increment



- Legend:**
- 1 - Intersection (2019 Collected Data)
 - 7 - Intersection (Uncollected Data)
 - 100 - ATR Volume
 - 100 - Approach Volume
 - ↯ - Illegal movement

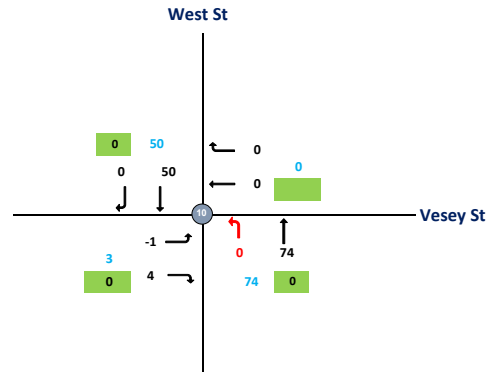

CBD Tolling
LM - Traffic Flowmap #7
MD No-Action Increment



- Legend:**
- 1 - Intersection (2019 Collected Data)
 - 7 - Intersection (Uncollected Data)
 - 100 - ATR Volume
 - 100 - Approach Volume

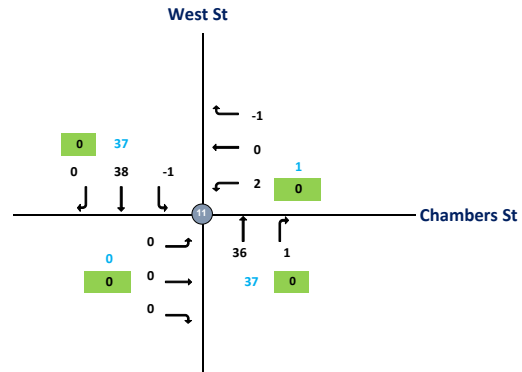

CBD Tolling
LM - Traffic Flowmap #8
MD No-Action Increment



- Legend:**
- Intersection (2019 Collected Data)
 - Intersection (Uncollected Data)
 - ATR Volume
 - Approach Volume

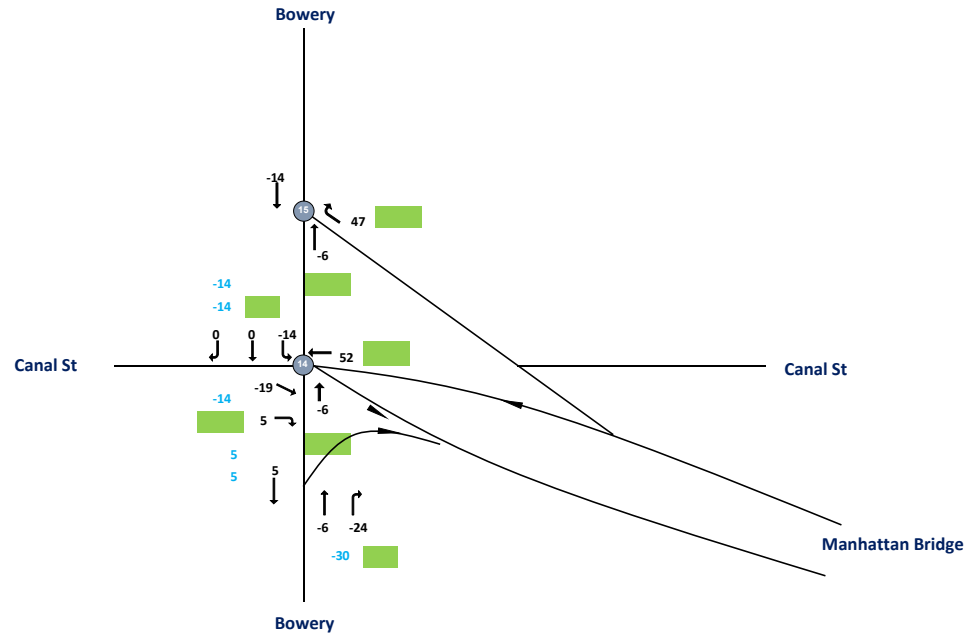

Intersection	Node	Approach	Total Volume					
			Inbound/Outbound					
			MD Peak Hour					
			L2	L	T	R	R2	Total
Edgar St. and Trinity Pl. 2019 (TMC-010)	1							
Edgar St.	1	EB	0	0	0	0	0	
478 Exit Ramp.	1	NE	2	119	0	0	0	
Trinity Pl.	1	NB	0	-9	-81	0	0	
Trinity Pl.	1	SB	0	0	0	0	0	31
Rector St. and Trinity Pl. 2019 (TMC-011)	2							
Rector St.	2	EB	0	-5	0	0	0	
Rector St.	2	WB	0	0	0	0	0	
Trinity Pl.	2	NB	0	0	32	6	0	
Trinity Pl.	2	SB	0	0	0	0	0	33
West St. and HCT Exit. 2019 (TMC-012)	3							
-	3	EB	0	0	0	0	0	
HCT Exit.	3	WB	0	97	0	0	0	
West St.	3	NB	0	0	-12	0	46	
West St.	3	SB	0	0	-6	0	0	125
West St. and HCT Exit. 2019 (TMC-012)	333							
W. Thams St.	333	EB	0	0	0	0	0	
HCT Exit.	333	WB	0	0	0	98	0	
West St.	333	NB	0	0	-12	0	0	
West St.	333	SB	0	0	-6	0	0	80
Chambers St. and Centre St. 2018	4							
Chambers St.	4	EB	0	0	0	-19	0	
-	4	WB	0	0	0	0	0	
Centre St.	4	NB	0	-81	-102	0	0	
Centre St.	4	SB	0	0	-9	0	0	-211
Hudson St. and Canal St. 2018	5							
Canal St.	5	EB	1	3	7	0	0	
Canal St.	5	WB	0	0	-48	-8	0	
Hudson St.	5	NB	0	0	0	-5	-2	
Hudson St.	5	SB	0	0	0	0	0	-52

Hudson St. and Canal St.								
2018	555							
Canal St.	555	EB	0	0	5	0	0	
Canal St.	555	WB	0	0	-56	0	0	
Hudson St.	555	NB	0	0	0	0	0	
Hudson St.	555	SB	0	0	0	0	0	-51
West St. and Canal St N.								
2018	7							
Canal St N.	7	EB	0	0	0	0	0	
-	7	WB	0	0	0	0	0	
West St.	7	NB	0	0	31	-2	0	
West St.	7	SB	0	-12	51	0	0	68
West St. and Canal St S.								
2018	777							
-	777	EB	0	0	0	0	0	
Canal St S.	777	WB	0	0	0	0	0	
West St.	777	NB	0	0	31	0	0	
West St.	777	SB	0	0	39	0	0	70
West St. and Albany St.								
2019 (TMC-013)	9							
Albany St.	9	EB	0	0	0	2	0	
-	9	WB	0	0	0	0	0	
West St.	9	NB	0	0	88	5	0	
West St.	9	SB	0	0	64	0	0	159
West St. and Vesey St.								
2019 (TMC-014)	10							
Vesey St.	10	EB	0	-1	0	4	0	
Vesey St.	10	WB	0	0	0	0	0	
West St.	10	NB	0	0	74	0	0	
West St.	10	SB	0	0	50	0	0	31
West St. and Chambers St.								
2019 (TMC-015)	11							
Chambers St.	11	EB	0	0	0	0	0	
Chambers St.	11	WB	0	2	0	-1	0	
West St.	11	NB	0	0	36	1	0	
West St.	11	SB	0	-1	38	0	0	75

Bowey and Canal St./Manhattan Bridge Off-Ramp								
2018	14							
Canal St.	14	EB	0	0	-19	5	0	
Manhattan Bridge Off-Ramp	14	WB	0	0	52	0	0	
Bowey	14	NB	0	0	-6	-24	0	
Bowey	14	SB	0	-14	0	0	0	-6
Bowey and Manhattan Bridge Off-Ramp								
2018	15							
	15	EB	0	0	0	0	0	
Manhattan Bridge Off-Ramp	15	WB	0	0	0	47	0	
Bowey	15	NB	0	0	-6	0	0	
Bowey	15	SB	0	0	-14	0	0	27
6th Ave. and Watts St								
2018	18							
Watts St	18	EB	0	0	0	0	0	
Watts St	18	WB	0	0	0	0	0	
6th Ave.	18	NB	0	-8	-78	0	0	
6th Ave.	18	SB	0	0	0	0	0	-86
6th Ave. and Canal St.								
2018	19							
Canal St.	19	EB	0	0	17	0	0	
Canal St.	19	WB	0	0	18	4	0	
6th Ave.	19	NB	0	-25	-112	-1	0	
Laight St.	19	NE	0	0	0	-6	0	-105

CBD Tolling
LM - Traffic Flowmap #1
PM No-Action Increment



- Legend:**
- 1 - Intersection (2019 Collected Data)
 - 7 - Intersection (Uncollected Data)
 - 100 - ATR Volume
 - 100 - Approach Volume

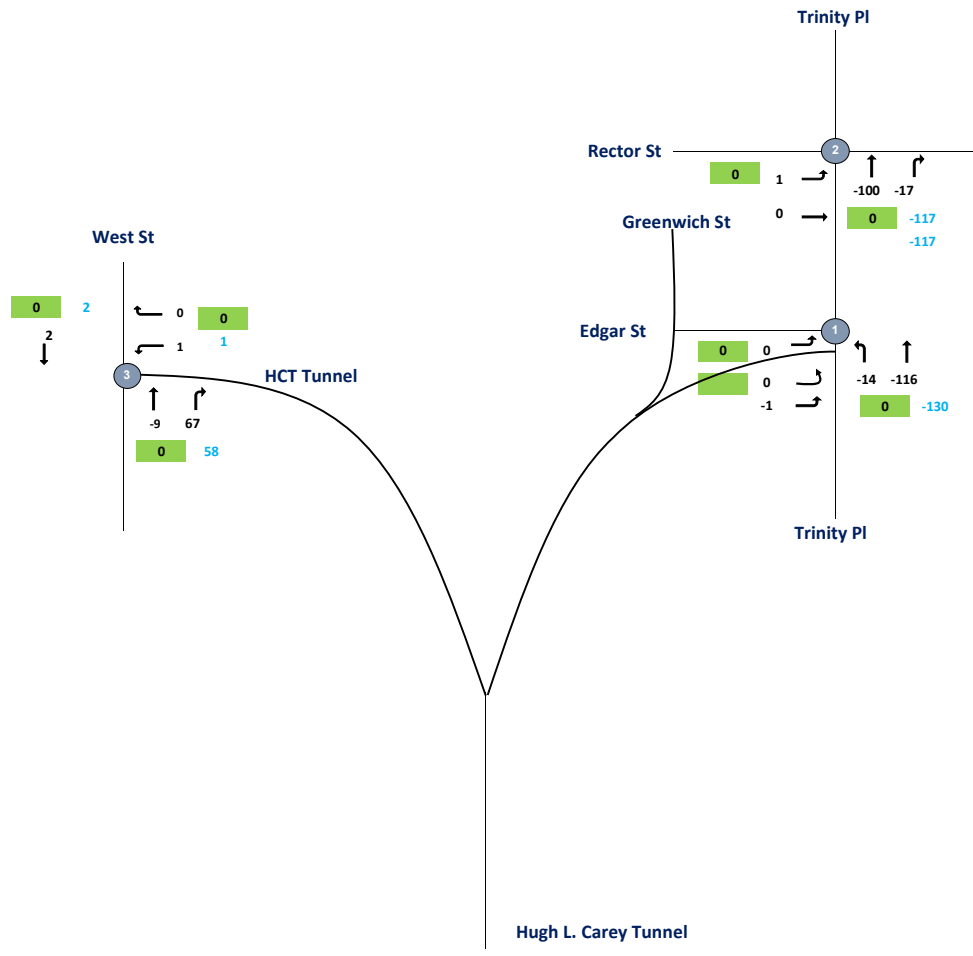

CBD Tolling
LM - Traffic Flowmap #2
PM No-Action Increment

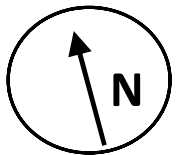

Legend:

- 1 - Intersection (2019 Collected Data)
- 7 - Intersection (Uncollected Data)
- 100 - ATR Volume
- 100 - Approach Volume

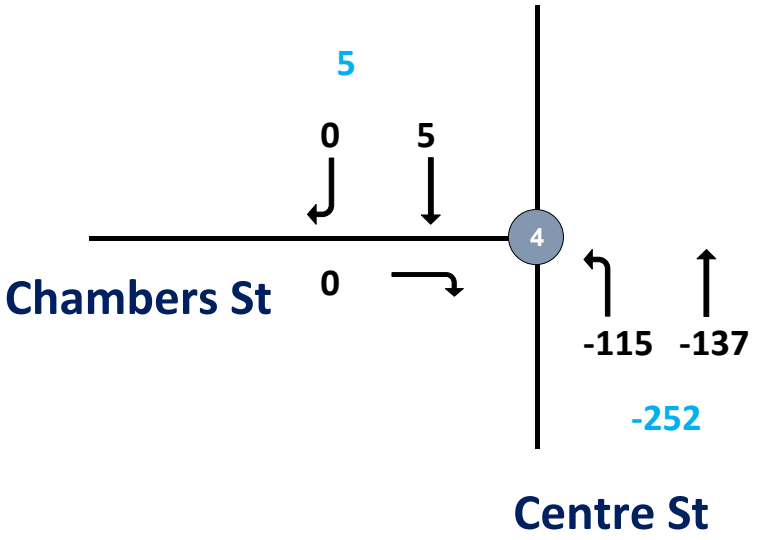

CBD Tolling
LM - Traffic Flowmap #3
PM No-Action Increment



- Legend:**
- Intersection (2019 Collected Data)
 - 7 - Intersection (Uncollected Data)
 - 100 - ATR Volume
 - 100 - Approach Volume

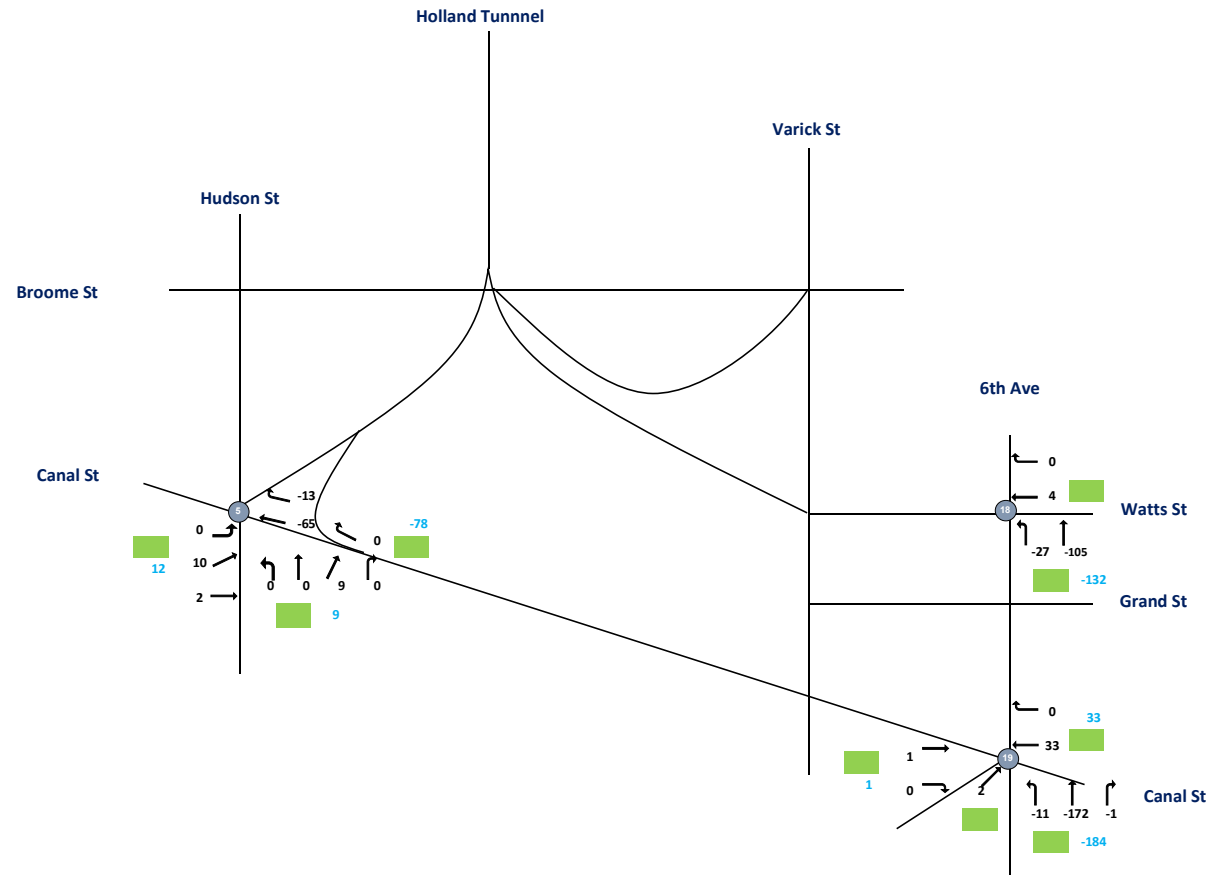

CBD Tolling
LM - Traffic Flowmap #4
PM No-Action Increment



- Legend:**
- Intersection (2019 Collected Data)
 - Intersection (Uncollected Data)
 - 100 - ATR Volume
 - 100 - Approach Volume

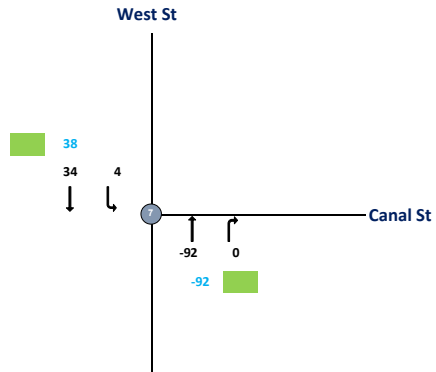

CBD Tolling
LM - Traffic Flowmap #5
PM No-Action Increment



- Legend:**
- 1 - Intersection (2019 Collected Data)
 - 7 - Intersection (Uncollected Data)
 - 100 - ATR Volume
 - 100 - Approach Volume

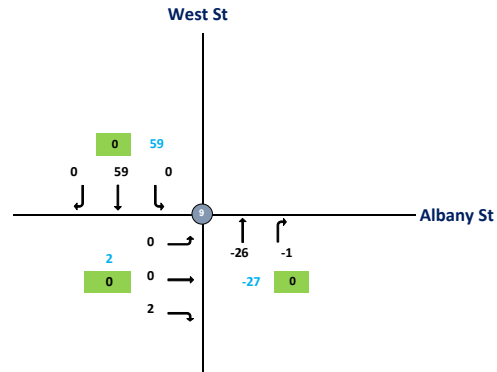

CBD Tolling
LM - Traffic Flowmap #6
PM No-Action Increment



- Legend:**
- 1 - Intersection (2019 Collected Data)
 - 7 - Intersection (Uncollected Data)
 - 100 - ATR Volume
 - 100 - Approach Volume
 - ↯ - Illegal movement

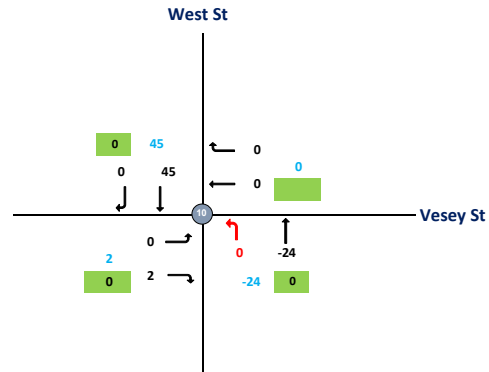

CBD Tolling
LM - Traffic Flowmap #7
PM No-Action Increment



- Legend:**
- 1 - Intersection (2019 Collected Data)
 - 7 - Intersection (Uncollected Data)
 - 100 - ATR Volume
 - 100 - Approach Volume

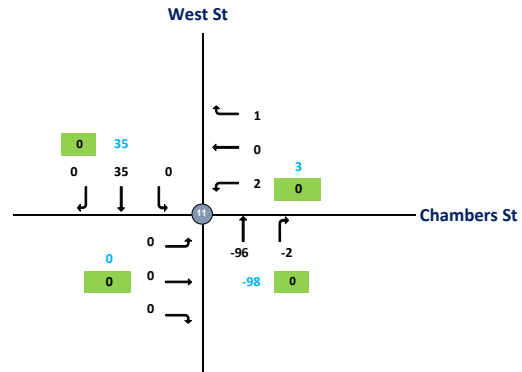

CBD Tolling
LM - Traffic Flowmap #8
PM No-Action Increment



- Legend:**
- Intersection (2019 Collected Data)
 - Intersection (Uncollected Data)
 - ATR Volume
 - Approach Volume

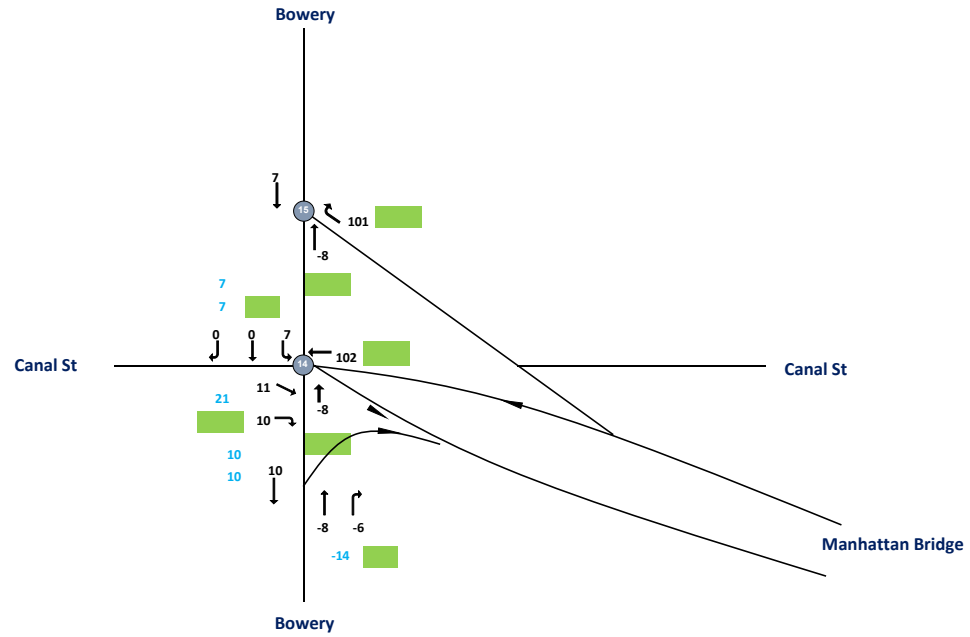

Intersection	Node	Approach	Total Volume					
			Inbound/Outbound					
			PM Peak Hour					
			L2	L	T	R	R2	Total
Edgar St. and Trinity Pl. 2019 (TMC-010)	1							
Edgar St.	1	EB	0	0	0	0	0	
478 Exit Ramp.	1	NE	0	-1	0	0	0	
Trinity Pl.	1	NB	0	-14	-116	0	0	
Trinity Pl.	1	SB	0	0	0	0	0	-131
Rector St. and Trinity Pl. 2019 (TMC-011)	2							
Rector St.	2	EB	0	1	0	0	0	
Rector St.	2	WB	0	0	0	0	0	
Trinity Pl.	2	NB	0	0	-100	-17	0	
Trinity Pl.	2	SB	0	0	0	0	0	-116
West St. and HCT Exit. 2019 (TMC-012)	3							
-	3	EB	0	0	0	0	0	
HCT Exit.	3	WB	0	1	0	0	0	
West St.	3	NB	0	0	-9	0	67	
West St.	3	SB	0	0	2	0	0	61
West St. and HCT Exit. 2019 (TMC-012)	333							
W. Thams St.	333	EB	0	0	0	0	0	
HCT Exit.	333	WB	0	0	0	0	0	
West St.	333	NB	0	0	-9	0	0	
West St.	333	SB	0	0	2	0	0	-7
Chambers St. and Centre St. 2018	4							
Chambers St.	4	EB	0	0	0	0	0	
-	4	WB	0	0	0	0	0	
Centre St.	4	NB	0	-115	-137	0	0	
Centre St.	4	SB	0	0	5	0	0	-247
Hudson St. and Canal St. 2018	5							
Canal St.	5	EB	0	10	2	0	0	
Canal St.	5	WB	0	0	-65	-13	0	
Hudson St.	5	NB	0	0	0	9	0	
Hudson St.	5	SB	0	0	0	0	0	-57

Hudson St. and Canal St.								
2018	555							
Canal St.	555	EB	0	0	2	0	0	
Canal St.	555	WB	0	0	-78	0	0	
Hudson St.	555	NB	0	0	0	0	0	
Hudson St.	555	SB	0	0	0	0	0	-76
West St. and Canal St N.								
2018	7							
Canal St N.	7	EB	0	0	0	0	0	
-	7	WB	0	0	0	0	0	
West St.	7	NB	0	0	-92	0	0	
West St.	7	SB	0	4	34	0	0	-54
West St. and Canal St S.								
2018	777							
-	777	EB	0	0	0	0	0	
Canal St S.	777	WB	0	0	0	0	0	
West St.	777	NB	0	0	-92	0	0	
West St.	777	SB	0	0	38	0	0	-54
West St. and Albany St.								
2019 (TMC-013)	9							
Albany St.	9	EB	0	0	0	2	0	
-	9	WB	0	0	0	0	0	
West St.	9	NB	0	0	-26	-1	0	
West St.	9	SB	0	0	59	0	0	34
West St. and Vesey St.								
2019 (TMC-014)	10							
Vesey St.	10	EB	0	0	0	2	0	
Vesey St.	10	WB	0	0	0	0	0	
West St.	10	NB	0	0	-24	0	0	
West St.	10	SB	0	0	45	0	0	-131
West St. and Chambers St.								
2019 (TMC-015)	11							
Chambers St.	11	EB	0	0	0	0	0	
Chambers St.	11	WB	0	2	0	1	0	
West St.	11	NB	0	0	-96	-2	0	
West St.	11	SB	0	0	35	0	0	-60

Bowey and Canal St./Manhattan Bridge Off-Ramp								
2018	14							
Canal St.	14	EB	0	0	11	10	0	
Manhattan Bridge Off-Ramp	14	WB	0	0	102	0	0	
Bowey	14	NB	0	0	-8	-6	0	
Bowey	14	SB	0	7	0	0	0	116
Bowey and Manhattan Bridge Off-Ramp								
2018	15							
	15	EB	0	0	0	0	0	
Manhattan Bridge Off-Ramp	15	WB	0	0	0	101	0	
Bowey	15	NB	0	0	-8	0	0	
Bowey	15	SB	0	0	7	0	0	100
6th Ave. and Watts St								
2018	18							
Watts St	18	EB	0	0	0	0	0	
Watts St	18	WB	0	0	4	0	0	
6th Ave.	18	NB	0	-27	-105	0	0	
6th Ave.	18	SB	0	0	0	0	0	-128
6th Ave. and Canal St.								
2018	19							
Canal St.	19	EB	0	0	1	0	0	
Canal St.	19	WB	0	0	33	0	0	
6th Ave.	19	NB	0	-11	-172	-1	0	
Laight St.	19	NE	0	0	0	2	0	-148

CBD Tolling
LT #1 - Traffic Flowmap
AM No-Action Increment



- Legend:**
- 1 - Intersection (2019 Collected Data)
 - 7 - Intersection (Pre-2019 Collected Data)
 - 100 - ATR Volume
 - 100 - Approach Volume

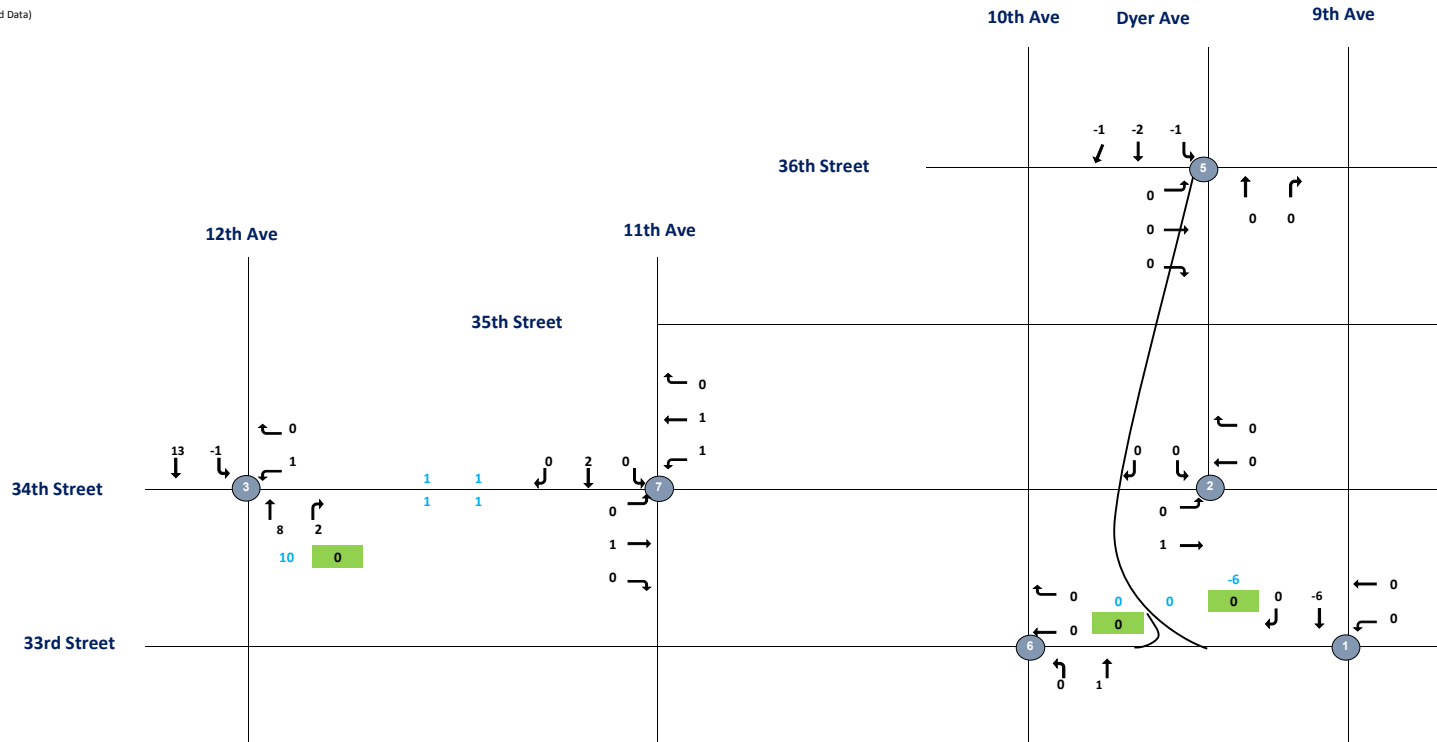

CBD Tolling
LT #2 - Traffic Flowmap
AM No-Action Increment



- Legend:**
- 1 - Intersection (2019 Collected Data)
 - 4 - Intersection (Pre-2019 Collected Data)
 - 100 - ATR Volume
 - 100 - Approach Volume

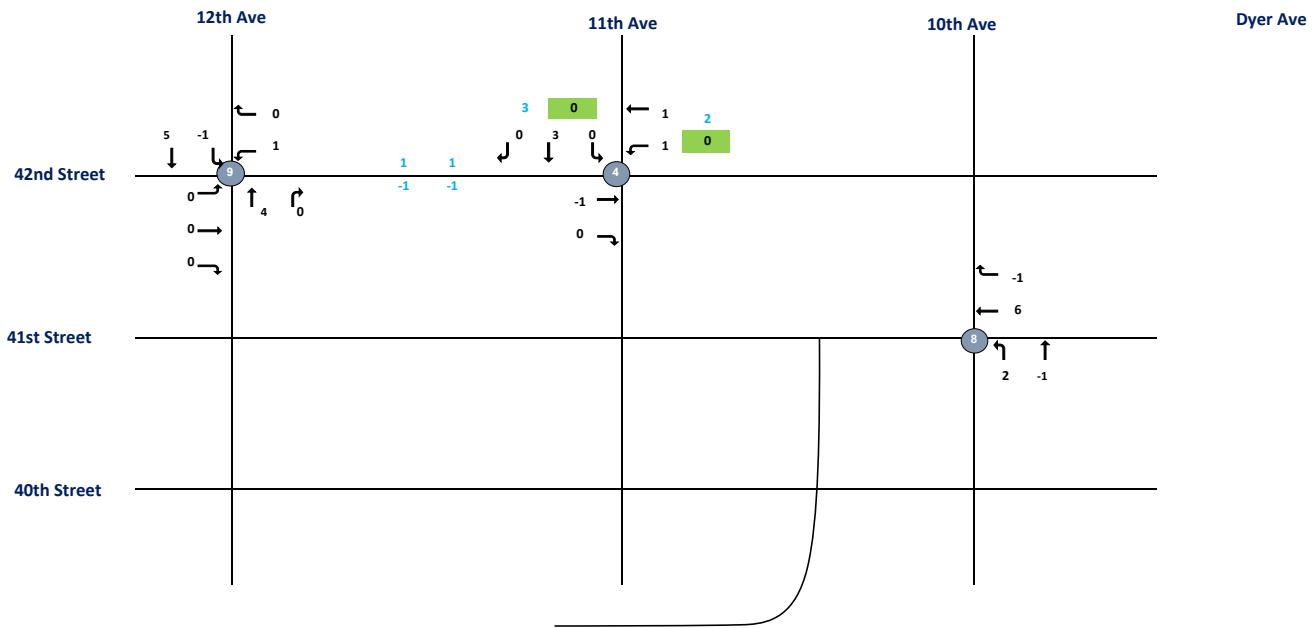

LT

8:00:00 AM

Intersection	Node	Approach	Total Vehicles					
			Inbound/Outbound					
			AM Peak Hour					
			L2	L	T	R	R2	Total
33rd Street and 9th Avenue 2019 (WRY-TMC-109)	1							
33rd Street	1	EB	0	0	0	0	0	
33rd Street	1	WB	0	0	0	0	0	
9th Avenue	1	NB	0	0	0	0	0	
9th Avenue	1	SB	0	0	-6	0	0	-6
34th Street and Dyer Avenue 2019 (WRY-TMC-105)	2							
34th Street	2	EB	0	0	1	0	0	
34th Street	2	WB	0	0	0	0	0	
Dyer Avenue	2	NB	0	0	0	0	0	
Dyer Avenue	2	SB	0	0	0	0	0	1
34th Street and 12th Avenue 2019 (PABT-TMC-055)	3							
34th Street	3	EB	0	0	0	0	0	
34th Street	3	WB	0	1	0	0	0	
12th Avenue	3	NB	0	0	8	2	0	
12th Avenue	3	SB	0	-1	13	0	0	23
42nd Street and 11th Avenue 2019 (PABT-TMC-052)	4							
42nd Street	4	EB	0	0	-1	0	0	
42nd Street	4	WB	0	1	1	0	0	
11th Avenue	4	NB	0	0	0	0	0	
11th Avenue	4	SB	0	0	3	0	0	4
36th Street and Dyer Avenue 2019 (PABT-TMC-060)	5							
36th Street	5	EB	0	0	0	0	0	
36th Street	5	WB	0	0	0	0	0	
Dyer Avenue	5	NB	0	0	0	0	0	
Dyer Avenue	5	SB	0	-1	-2	-1	0	-4
33rd Street and 10th Avenue 2019 (WRY-TMC-108)	6							
33rd Street	6	EB	0	0	0	0	0	
33rd Street	6	WB	0	0	0	0	0	
10th Avenue	6	NB	0	0	1	0	0	
10th Avenue	6	SB	0	0	0	0	0	1

34th Street and 11th Avenue 2019 (PABT-TMC-044)	7								
34th Street	7	EB	0	0	1	0	0		
34th Street	7	WB	0	1	1	0	0		
11th Avenue	7	NB	0	0	0	0	0		
11th Avenue	7	SB	0	0	2	0	0		5
34th Street and 11th Avenue 2019 (PABT-TMC-040)	8								
34th Street	8	EB	0	0	0	0	0		
34th Street	8	WB	0	0	6	-1	0		
11th Avenue	8	NB	0	2	-1	0	0		
11th Avenue	8	SB	0	0	0	0	0		6
42nd Street and 12th Avenue 2019 (PABT-TMC-057)	9								
42nd Street	9	EB	0	0	0	0	0		
42nd Street	9	WB	0	1	0	0	0		
12th Avenue	9	NB	0	0	4	0	0		
12th Avenue	9	SB	0	-1	5	0	0		9

CBD Tolling
LT #1 - Traffic Flowmap
MD No-Action Increment



- Legend:**
- 1 - Intersection (2019 Collected Data)
 - 7 - Intersection (Pre-2019 Collected Data)
 - 100 - ATR Volume
 - 100 - Approach Volume

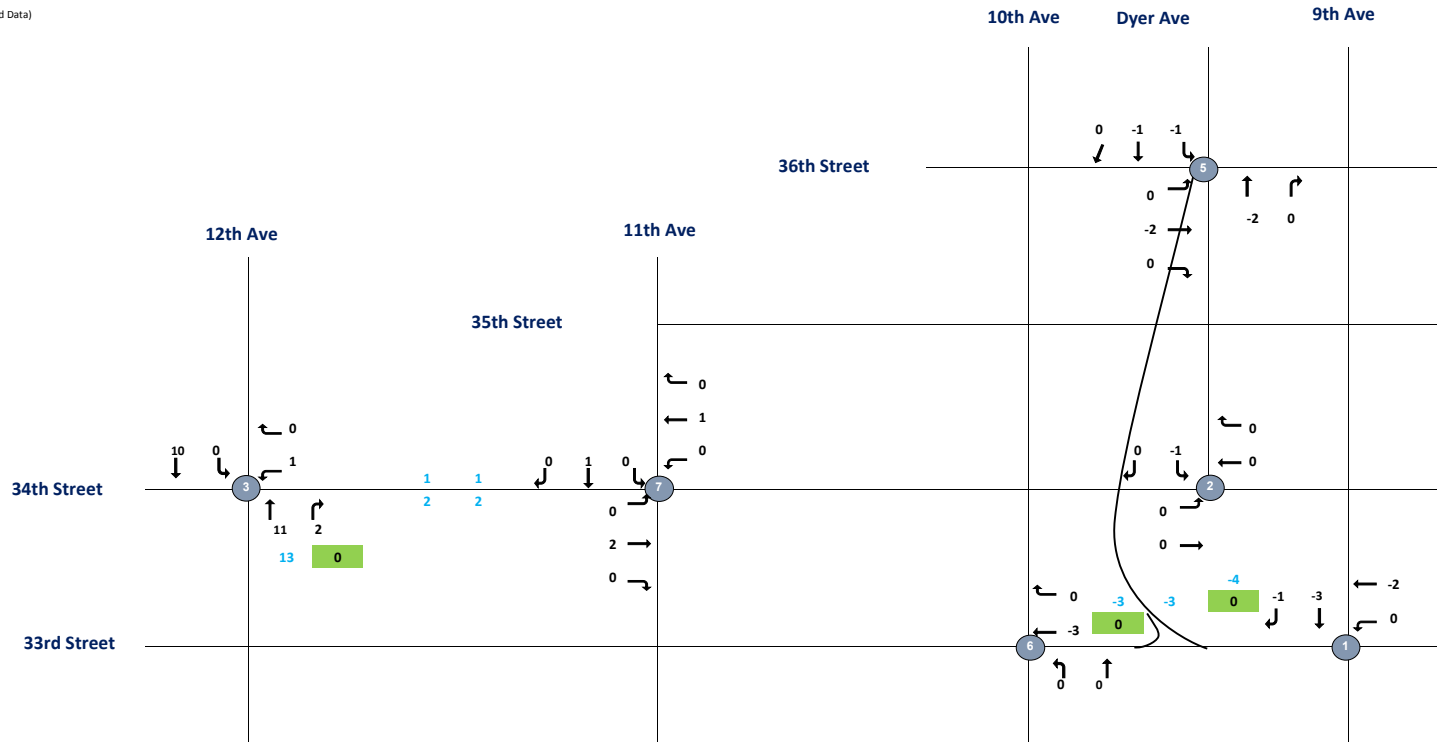

CBD Tolling
LT #2 - Traffic Flowmap
MD No-Action Increment



- Legend:**
- Intersection (2019 Collected Data)
 - Intersection (Pre-2019 Collected Data)
 - 100 - ATR Volume
 - 100 - Approach Volume

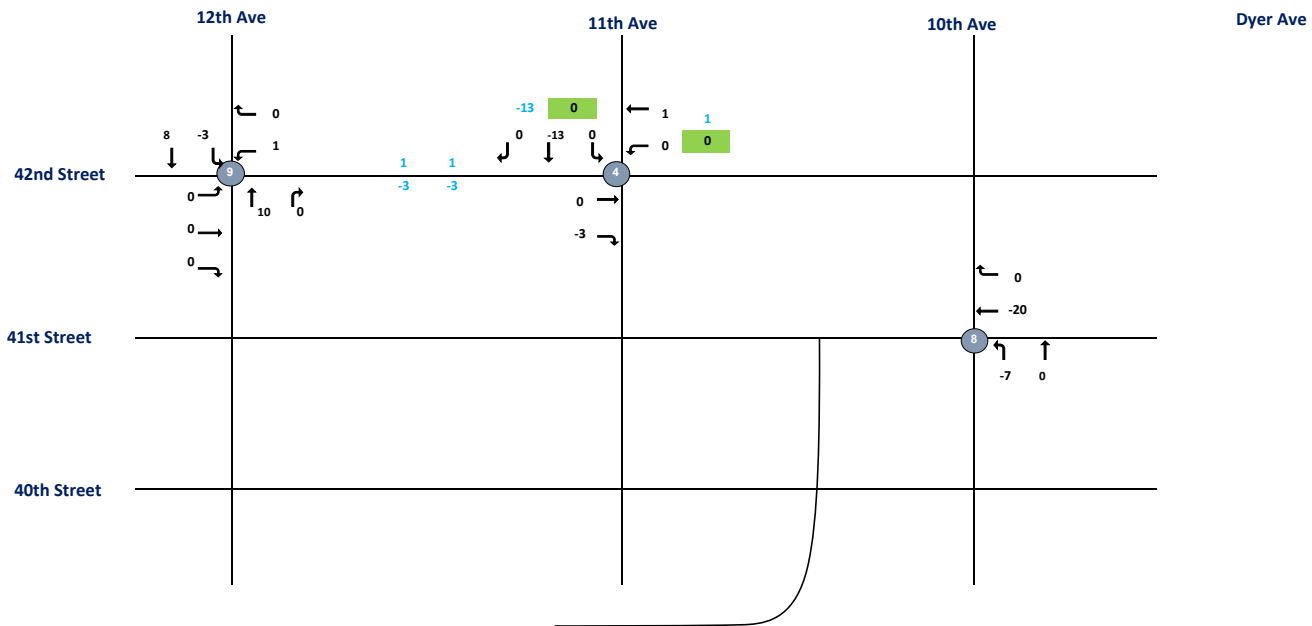

LT

12:00:00 PM

Intersection	Node	Approach	Total Vehicles					
			Inbound/Outbound					
			MD Peak Hour					
			L2	L	T	R	R2	Total
33rd Street and 9th Avenue 2019 (WRY-TMC-109)	1							
33rd Street	1	EB	0	0	0	0	0	
33rd Street	1	WB	0	0	-2	0	0	
9th Avenue	1	NB	0	0	0	0	0	
9th Avenue	1	SB	0	0	-3	-1	0	-6
34th Street and Dyer Avenue 2019 (WRY-TMC-105)	2							
34th Street	2	EB	0	0	0	0	0	
34th Street	2	WB	0	0	0	0	0	
Dyer Avenue	2	NB	0	0	0	0	0	
Dyer Avenue	2	SB	0	-1	0	0	0	-1
34th Street and 12th Avenue 2019 (PABT-TMC-055)	3							
34th Street	3	EB	0	0	0	0	0	
34th Street	3	WB	0	1	0	0	0	
12th Avenue	3	NB	0	0	11	2	0	
12th Avenue	3	SB	0	0	10	0	0	24
42nd Street and 11th Avenue 2019 (PABT-TMC-052)	4							
42nd Street	4	EB	0	0	0	-3	0	
42nd Street	4	WB	0	0	1	0	0	
11th Avenue	4	NB	0	0	0	0	0	
11th Avenue	4	SB	0	0	-13	0	0	-15
36th Street and Dyer Avenue 2019 (PABT-TMC-060)	5							
36th Street	5	EB	0	0	-2	0	0	
36th Street	5	WB	0	0	0	0	0	
Dyer Avenue	5	NB	0	0	-2	0	0	
Dyer Avenue	5	SB	0	-1	-1	0	0	-6
33rd Street and 10th Avenue 2019 (WRY-TMC-108)	6							
33rd Street	6	EB	0	0	0	0	0	
33rd Street	6	WB	0	0	-3	0	0	
10th Avenue	6	NB	0	0	0	0	0	
10th Avenue	6	SB	0	0	0	0	0	-3

34th Street and 11th Avenue 2019 (PABT-TMC-044)	7								
34th Street	7	EB	0	0	2	0	0		
34th Street	7	WB	0	0	1	0	0		
11th Avenue	7	NB	0	0	0	0	0		
11th Avenue	7	SB	0	0	1	0	0		4
34th Street and 11th Avenue 2019 (PABT-TMC-040)	8								
34th Street	8	EB	0	0	0	0	0		
34th Street	8	WB	0	0	-20	0	0		
11th Avenue	8	NB	0	-7	0	0	0		
11th Avenue	8	SB	0	0	0	0	0		-27
42nd Street and 12th Avenue 2019 (PABT-TMC-057)	9								
42nd Street	9	EB	0	0	0	0	0		
42nd Street	9	WB	0	1	0	0	0		
12th Avenue	9	NB	0	0	10	0	0		
12th Avenue	9	SB	0	-3	8	0	0		16

CBD Tolling
LT #1 - Traffic Flowmap
PM No-Action Increment



- Legend:**
- 1 - Intersection (2019 Collected Data)
 - 7 - Intersection (Pre-2019 Collected Data)
 - 100 - ATR Volume
 - 100 - Approach Volume

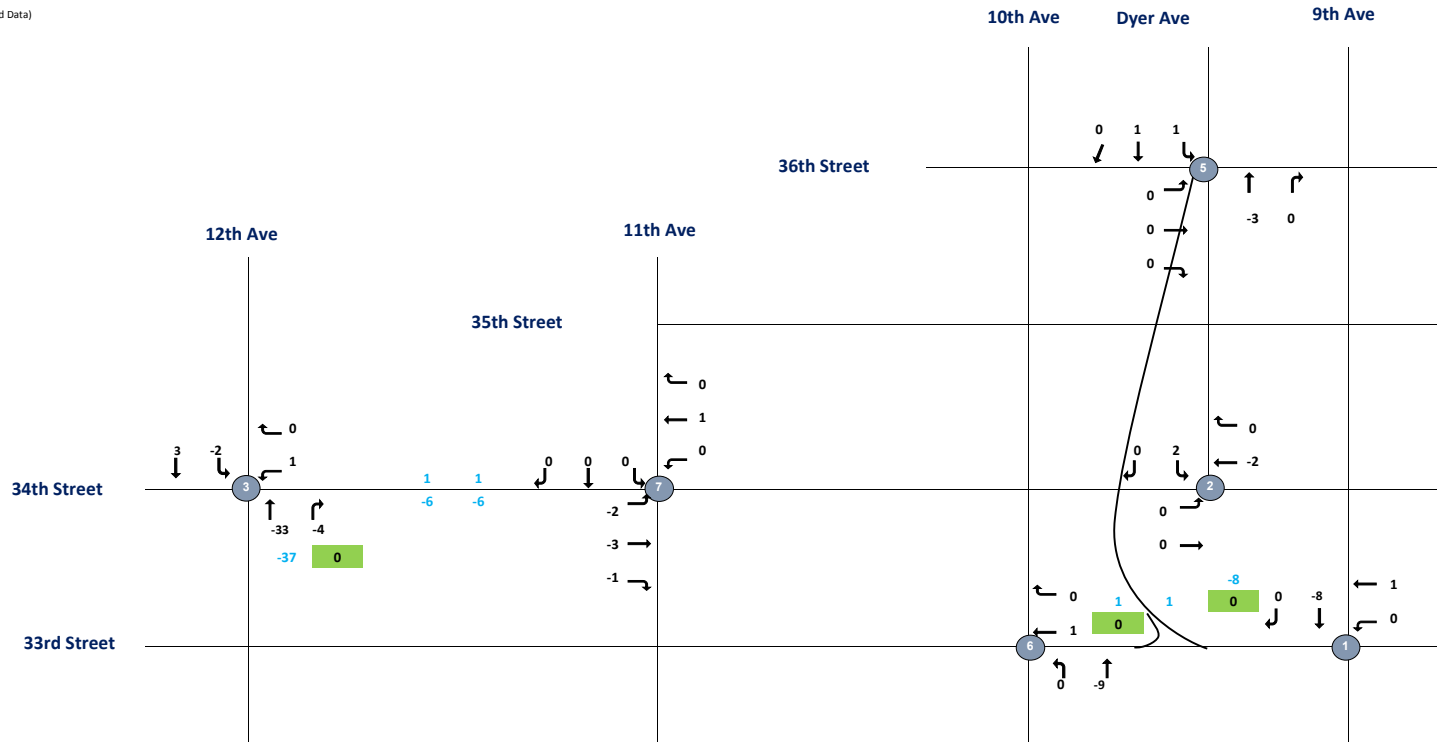

CBD Tolling
LT #2 - Traffic Flowmap
PM No-Action Increment



- Legend:**
- 1 - Intersection (2019 Collected Data)
 - 7 - Intersection (Pre-2019 Collected Data)
 - 100 - ATR Volume
 - 100 - Approach Volume

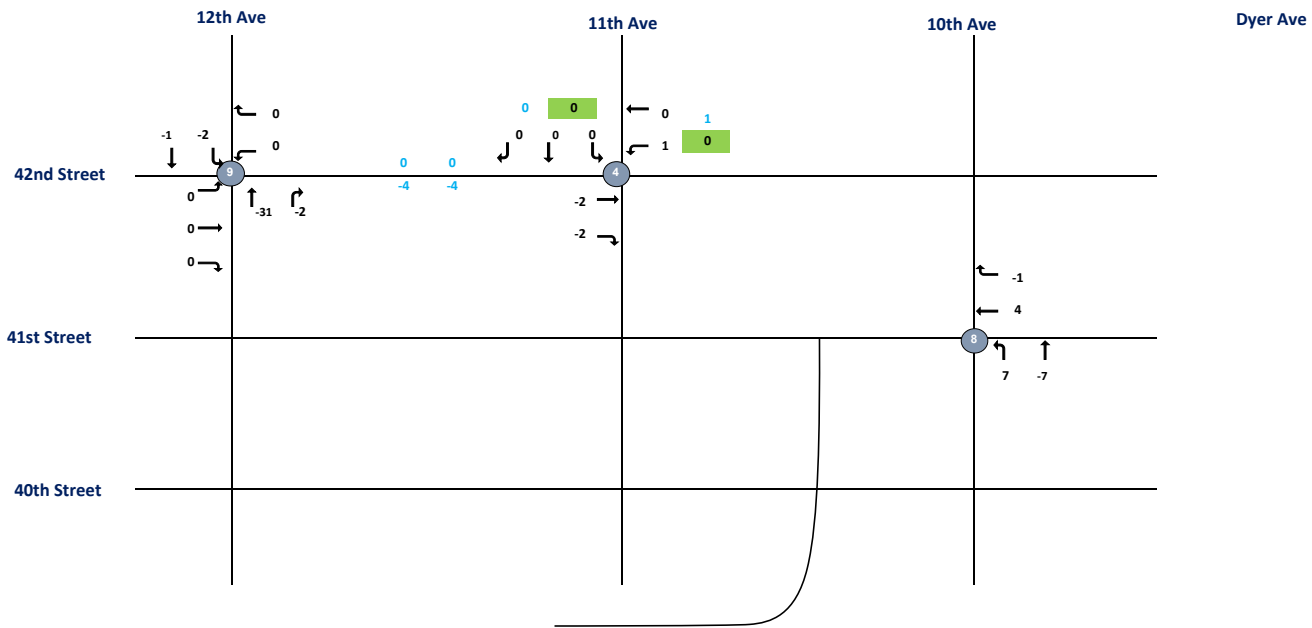

LT

5:00:00 PM

Intersection	Node	Approach	Total Vehicles					
			Inbound/Outbound					
			PM Peak Hour					
			L2	L	T	R	R2	Total
33rd Street and 9th Avenue 2019 (WRY-TMC-109)	1							
33rd Street	1	EB	0	0	0	0	0	
33rd Street	1	WB	0	0	1	0	0	
9th Avenue	1	NB	0	0	0	0	0	
9th Avenue	1	SB	0	0	-8	0	0	-7
34th Street and Dyer Avenue 2019 (WRY-TMC-105)	2							
34th Street	2	EB	0	0	0	0	0	
34th Street	2	WB	0	0	-2	0	0	
Dyer Avenue	2	NB	0	0	0	0	0	
Dyer Avenue	2	SB	0	2	0	0	0	0
34th Street and 12th Avenue 2019 (PABT-TMC-055)	3							
34th Street	3	EB	0	0	0	0	0	
34th Street	3	WB	0	1	0	0	0	
12th Avenue	3	NB	0	0	-33	-4	0	
12th Avenue	3	SB	0	-2	3	0	0	-35
42nd Street and 11th Avenue 2019 (PABT-TMC-052)	4							
42nd Street	4	EB	0	0	-2	-2	0	
42nd Street	4	WB	0	1	0	0	0	
11th Avenue	4	NB	0	0	0	0	0	
11th Avenue	4	SB	0	0	0	0	0	-3
36th Street and Dyer Avenue 2019 (PABT-TMC-060)	5							
36th Street	5	EB	0	0	0	0	0	
36th Street	5	WB	0	0	0	0	0	
Dyer Avenue	5	NB	0	0	-3	0	0	
Dyer Avenue	5	SB	0	1	1	0	0	-1
33rd Street and 10th Avenue 2019 (WRY-TMC-108)	6							
33rd Street	6	EB	0	0	0	0	0	
33rd Street	6	WB	0	0	1	0	0	
10th Avenue	6	NB	0	0	-9	0	0	
10th Avenue	6	SB	0	0	0	0	0	-8

34th Street and 11th Avenue 2019 (PABT-TMC-044)	7								
34th Street	7	EB	0	-2	-3	-1	0		
34th Street	7	WB	0	0	1	0	0		
11th Avenue	7	NB	0	0	0	0	0		
11th Avenue	7	SB	0	0	0	0	0		-5
34th Street and 11th Avenue 2019 (PABT-TMC-040)	8								
34th Street	8	EB	0	0	0	0	0		
34th Street	8	WB	0	0	4	-1	0		
11th Avenue	8	NB	0	7	-7	0	0		
11th Avenue	8	SB	0	0	0	0	0		3
42nd Street and 12th Avenue 2019 (PABT-TMC-057)	9								
42nd Street	9	EB	0	0	0	0	0		
42nd Street	9	WB	0	0	0	0	0		
12th Avenue	9	NB	0	0	-31	-2	0		
12th Avenue	9	SB	0	-2	-1	0	0		-36

**New Jersey
2021 No-Action Increment
AM Peak Hour**

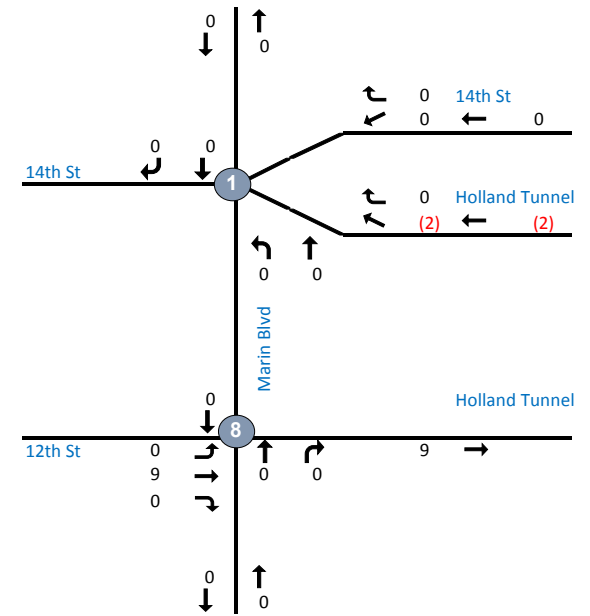
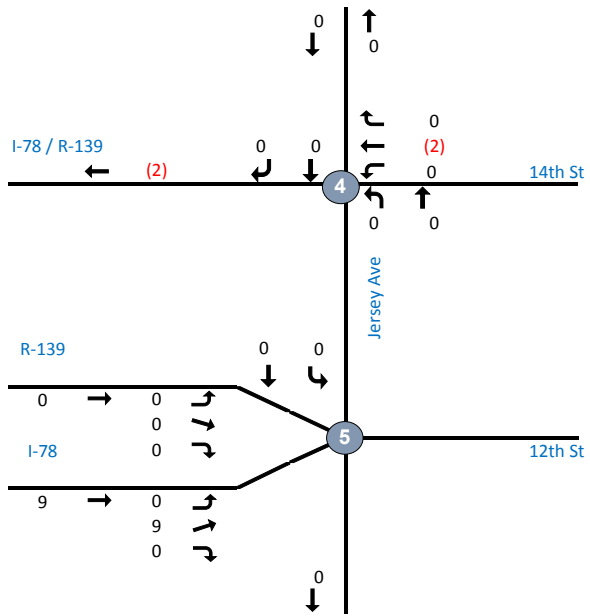

Intersection	Node	Approach	Total Vehicles					
			Inbound/Outbound					Total
			L2	L	T	R	R2	
14th Street (E-W) & Jersey Avenue (N-S)								
NJ-TMC-007.xlsx								
n/a	4	EB	0	0	0	0	0	
14th Street	4	WB	0	0	-2	0	0	
Jersey Avenue	4	NB	0	0	0	0	0	
Jersey Avenue	4	SB	0	0	0	0	0	-2
14th Street/Holland Tunnel (E-W) & Marin Boulevard (N-S)								
NJ-TMC-008.xlsx								
Holland Tunnel	1	WB	0	0	-2	0	0	
14th Street	1	SW	0	0	0	0	0	
Marin Boulevard	1	NB	0	0	0	0	0	
Marin Boulevard	1	SB	0	0	0	0	0	-2
12th Street (E-W) & Jersey Avenue (N-S)								
NJ-TMC-009.xlsx	5							
R-139	5	SE	0	0	0	0	0	
I-78	5	EB	0	0	9	0	0	
Jersey Avenue	5	NB	0	0	0	0	0	
Jersey Avenue	5	SB	0	0	0	0	0	9
12th Street (E-W) & Marin Blvd (N-S)								
NJ-TMC-010.xlsx	8							
12th Street/Holland Tunnel	8	EB	0	0	9	0	0	
n/a	8	WB	0	0	0	0	0	
Marin Boulevard	8	NB	0	0	0	0	0	
Marin Boulevard	8	SB	0	0	0	0	0	9

**New Jersey
2021 No-Action Increment
MD Peak Hour**

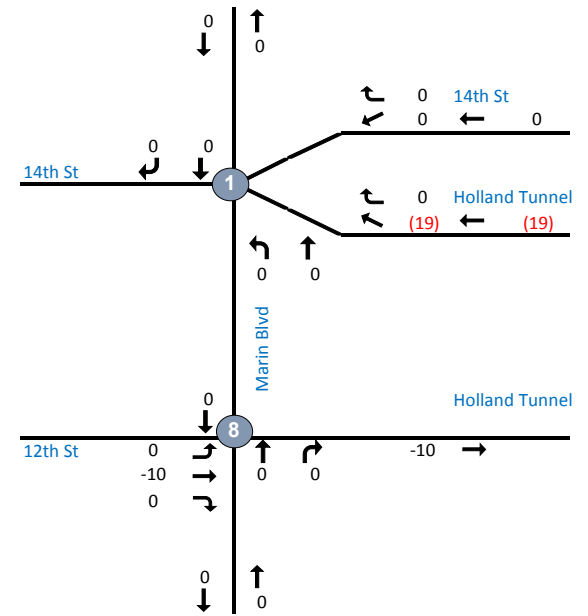
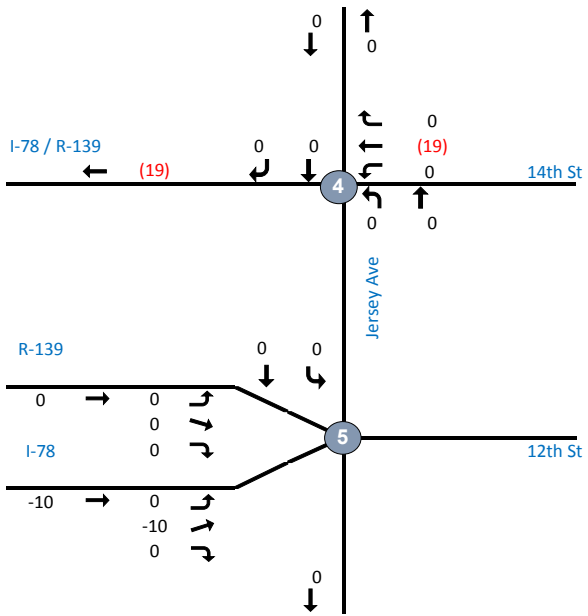

Intersection	Node	Approach	Total Vehicles						Total
			Inbound/Outbound						
			MD Peak Hour						
			L2	L	T	R	R2		
14th Street (E-W) & Jersey Avenue (N-S)									
NJ-TMC-007.xlsx									
n/a	4	EB	0	0	0	0	0		
14th Street	4	WB	0	0	-19	0	0		
Jersey Avenue	4	NB	0	0	0	0	0		
Jersey Avenue	4	SB	0	0	0	0	0	-19	
14th Street/Holland Tunnel (E-W) & Marin Boulevard (N-S)									
NJ-TMC-008.xlsx									
Holland Tunnel	1	WB	0	0	-19	0	0		
14th Street	1	SW	0	0	0	0	0		
Marin Boulevard	1	NB	0	0	0	0	0		
Marin Boulevard	1	SB	0	0	0	0	0	-19	
12th Street (E-W) & Jersey Avenue (N-S)									
NJ-TMC-009.xlsx	5								
R-139	5	SE	0	0	0	0	0		
I-78	5	EB	0	0	-10	0	0		
Jersey Avenue	5	NB	0	0	0	0	0		
Jersey Avenue	5	SB	0	0	0	0	0	-10	
12th Street (E-W) & Marin Blvd (N-S)									
NJ-TMC-010.xlsx	8								
12th Street/Holland Tunnel	8	EB	0	0	-10	0	0		
n/a	8	WB	0	0	0	0	0		
Marin Boulevard	8	NB	0	0	0	0	0		
Marin Boulevard	8	SB	0	0	0	0	0	-10	

**New Jersey
2021 No-Action Increment
PM Peak Hour**

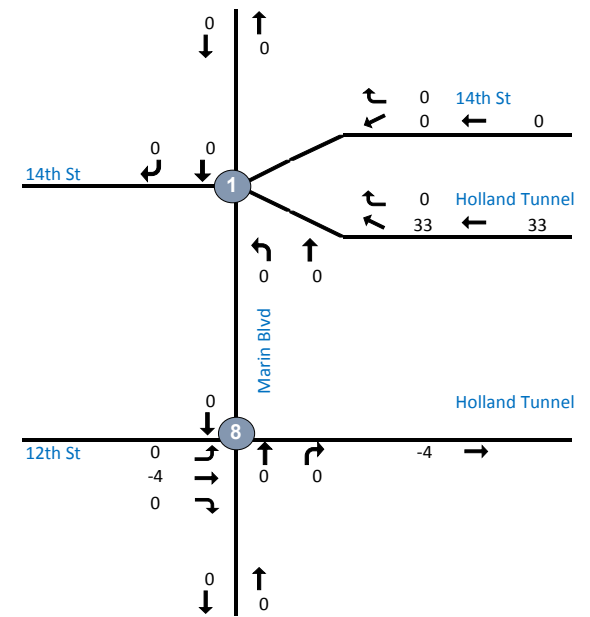
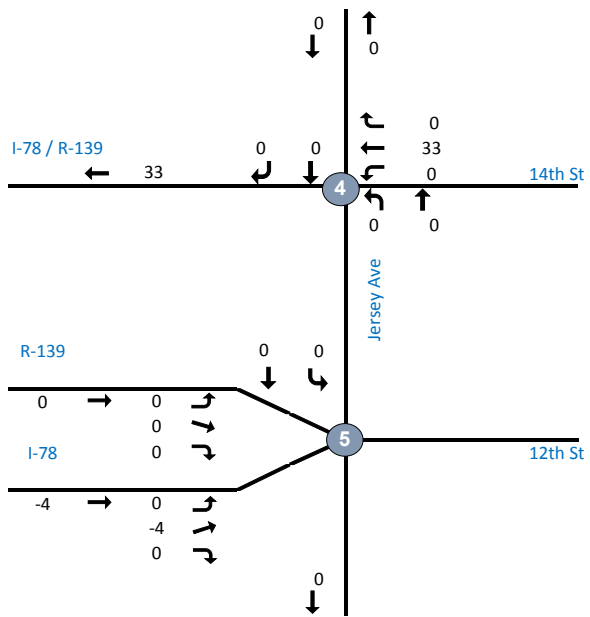

Intersection	Node	Approach	Total Vehicles						Total
			Inbound/Outbound						
			L2	L	T	R	R2		
14th Street (E-W) & Jersey Avenue (N-S)									
NJ-TMC-007.xlsx									
n/a	4	EB	0	0	0	0	0		
14th Street	4	WB	0	0	33	0	0		
Jersey Avenue	4	NB	0	0	0	0	0		
Jersey Avenue	4	SB	0	0	0	0	0	33	
14th Street/Holland Tunnel (E-W) & Marin Boulevard (N-S)									
NJ-TMC-008.xlsx									
Holland Tunnel	1	WB	0	0	33	0	0		
14th Street	1	SW	0	0	0	0	0		
Marin Boulevard	1	NB	0	0	0	0	0		
Marin Boulevard	1	SB	0	0	0	0	0	33	
12th Street (E-W) & Jersey Avenue (N-S)									
NJ-TMC-009.xlsx	5								
R-139	5	SE	0	0	0	0	0		
I-78	5	EB	0	0	-4	0	0		
Jersey Avenue	5	NB	0	0	0	0	0		
Jersey Avenue	5	SB	0	0	0	0	0	-4	
12th Street (E-W) & Marin Blvd (N-S)									
NJ-TMC-010.xlsx	8								
12th Street/Holland Tunnel	8	EB	0	0	-4	0	0		
n/a	8	WB	0	0	0	0	0		
Marin Boulevard	8	NB	0	0	0	0	0		
Marin Boulevard	8	SB	0	0	0	0	0	-4	

CBD Tolling
QMT - Traffic Flowmap
AM No-Action Increment



- Legend:**
- 1 - Intersection (2019 Collected Data)
 - 7 - Intersection (Uncollected Data)
 - 100 - ATR Volume
 - 100 - Approach Volume

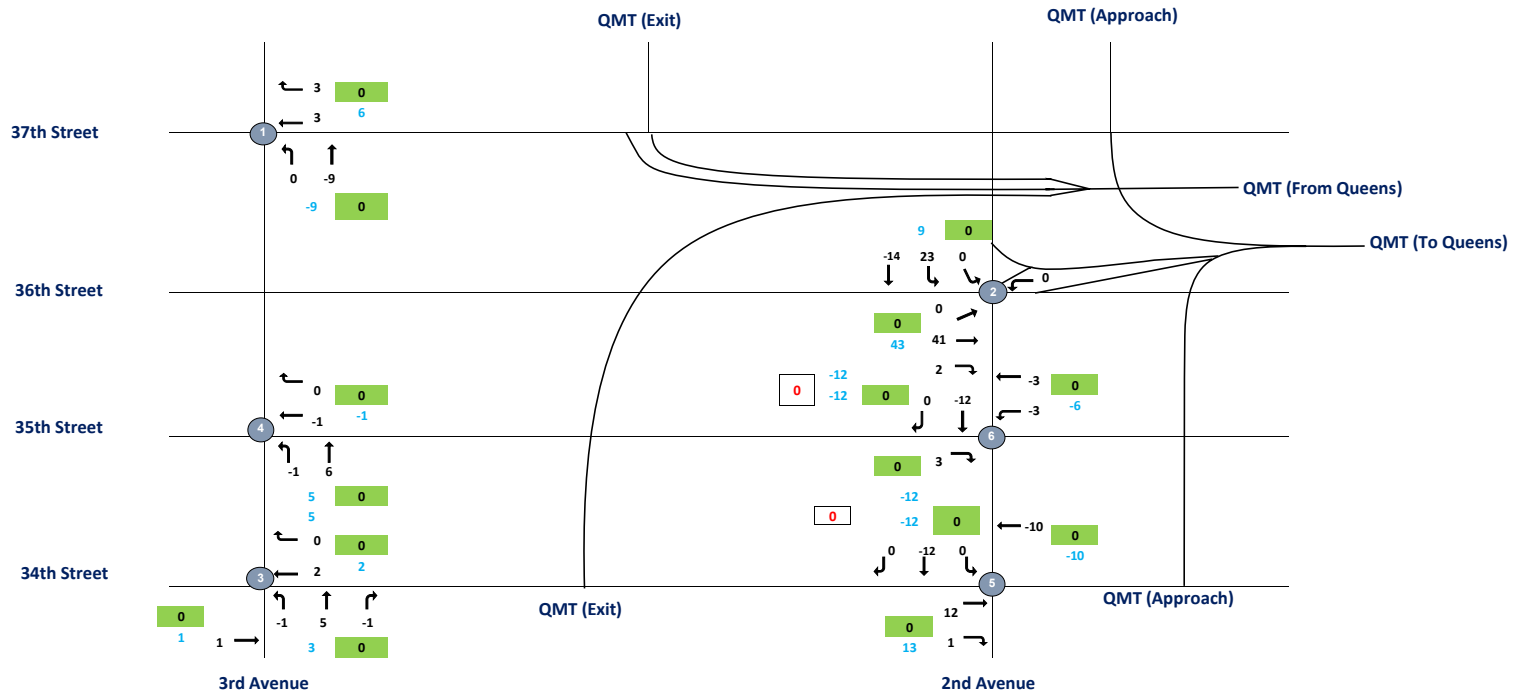

QM

8:00:00 AM

Intersection	Node	Approach	Balanced No-Action Increment						
			Inbound/Outbound						
			AM Peak Hour						
			L2	L	T	R	R2	Total	
37th St & 3rd Ave 2019 (TMC-016)	1								
37th St	1	EB	0	0	0	0	0		
37th St	1	WB	0	0	3	3	0		
3rd Ave	1	NB	0	0	-9	0	0		
3rd Ave	1	SB	0	0	0	0	0		-3
36th St & 2nd Ave 2019 (TMC-017)	2								
36th St	2	EB	0	0	41	2	0		
36th St	2	WB	0	0	0	0	0		
2nd Ave	2	NB	0	0	0	0	0		
2nd Ave	2	SB	0	23	-14	0	0		52
34th St & 3rd Ave 2019 (TMC-018)	3								
34th St	3	EB	0	0	1	0	0		
34th St	3	WB	0	0	2	0	0		
3rd Ave	3	NB	0	-1	5	-1	0		
	3	SB	0	0	0	0	0		6
35th St & 3rd Ave 2019 (TMC-019)	4								
35th St	4	EB	0	0	0	0	0		
35th St	4	WB	0	0	-1	0	0		
3rd Ave	4	NB	0	-1	6	0	0		
	4	SB	0	0	0	0	0		4
34th St & 2nd Ave 2019 (TMC-020)	5								
34th St	5	EB	0	0	12	1	0		
34th St	5	WB	0	0	-10	0	0		
2nd Ave	5	NB	0	0	0	0	0		
2nd Ave	5	SB	0	0	-12	0	0		-9
35th St & 2nd Ave 2019 (TMC-021)	6								
35th St	6	EB	0	0	0	3	0		
35th St	6	WB	0	-3	-3	0	0		
2nd Ave	6	NB	0	0	0	0	0		
2nd Ave	6	SB	0	0	-12	0	0		-15

CBD Tolling
QMT - Traffic Flowmap
MD No-Action Increment



- Legend:**
- 1 - Intersection (2019 Collected Data)
 - 7 - Intersection (Uncollected Data)
 - 100 - ATR Volume
 - 100 - Approach Volume

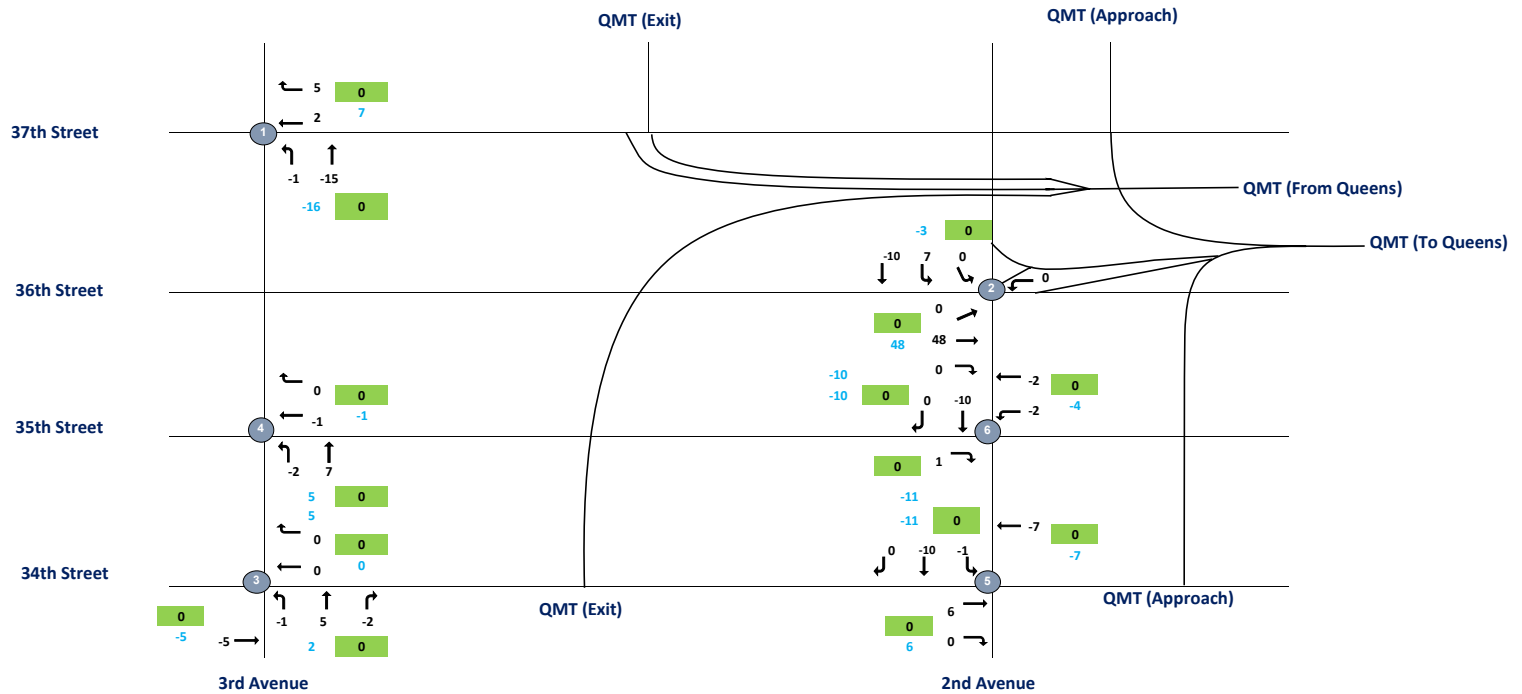

QM

1:00:00 PM

Intersection	Node	Approach	Balanced No-Action Increment					
			Inbound/Outbound					Total
			MD Peak Hour					
L2	L	T	R	R2				
37th St & 3rd Ave 2019 (TMC-016)	1							
37th St	1	EB	0	0	0	0	0	
37th St	1	WB	0	0	2	5	0	
3rd Ave	1	NB	0	-1	-15	0	0	
3rd Ave	1	SB	0	0	0	0	0	-9
36th St & 2nd Ave 2019 (TMC-017)	2							
36th St	2	EB	0	0	48	0	0	
36th St	2	WB	0	0	0	0	0	
2nd Ave	2	NB	0	0	0	0	0	
2nd Ave	2	SB	0	7	-10	0	0	45
34th St & 3rd Ave 2019 (TMC-018)	3							
34th St	3	EB	0	0	-5	0	0	
34th St	3	WB	0	0	0	0	0	
3rd Ave	3	NB	0	-1	5	-2	0	
	3	SB	0	0	0	0	0	-3
35th St & 3rd Ave 2019 (TMC-019)	4							
35th St	4	EB	0	0	0	0	0	
35th St	4	WB	0	0	-1	0	0	
3rd Ave	4	NB	0	-2	7	0	0	
	4	SB	0	0	0	0	0	4
34th St & 2nd Ave 2019 (TMC-020)	5							
34th St	5	EB	0	0	6	0	0	
34th St	5	WB	0	0	-7	0	0	
2nd Ave	5	NB	0	0	0	0	0	
2nd Ave	5	SB	0	-1	-10	0	0	-12
35th St & 2nd Ave 2019 (TMC-021)	6							
35th St	6	EB	0	0	0	1	0	
35th St	6	WB	0	-2	-2	0	0	
2nd Ave	6	NB	0	0	0	0	0	
2nd Ave	6	SB	0	0	-10	0	0	-13

CBD Tolling
QMT - Traffic Flowmap
PM No-Action Increment



- Legend:**
- 1 - Intersection (2019 Collected Data)
 - 7 - Intersection (Uncollected Data)
 - 100 - ATR Volume
 - 100 - Approach Volume

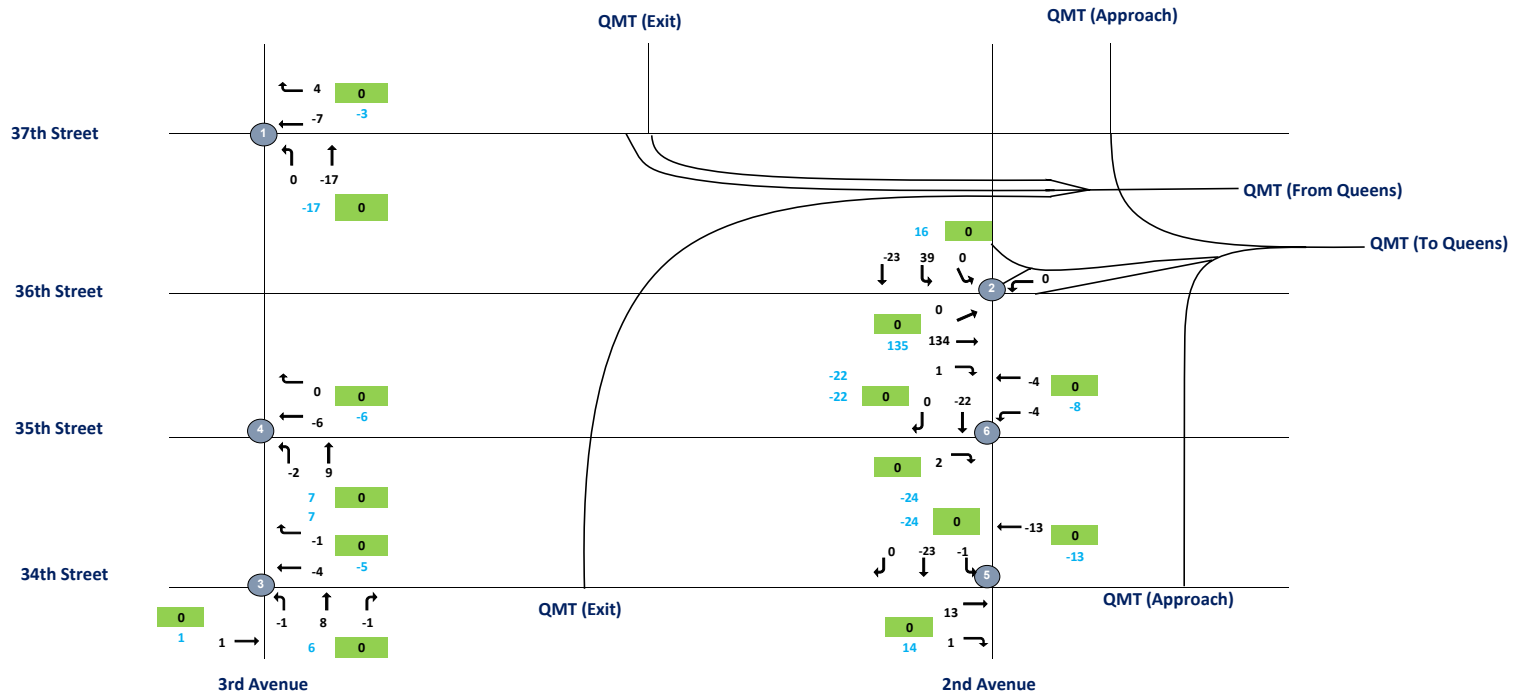

QM

5:00:00 PM

Intersection	Node	Approach	Balanced No-Action Increment					
			Inbound/Outbound					Total
			PM Peak Hour					
L2	L	T	R	R2				
37th St & 3rd Ave 2019 (TMC-016)	1							
37th St	1	EB	0	0	0	0	0	
37th St	1	WB	0	0	-7	4	0	
3rd Ave	1	NB	0	0	-17	0	0	
3rd Ave	1	SB	0	0	0	0	0	-20
36th St & 2nd Ave 2019 (TMC-017)	2							
36th St	2	EB	0	0	134	1	0	
36th St	2	WB	0	0	0	0	0	
2nd Ave	2	NB	0	0	0	0	0	
2nd Ave	2	SB	0	39	-23	0	0	151
34th St & 3rd Ave 2019 (TMC-018)	3							
34th St	3	EB	0	0	1	0	0	
34th St	3	WB	0	0	-4	-1	0	
3rd Ave	3	NB	0	-1	8	-1	0	
	3	SB	0	0	0	0	0	2
35th St & 3rd Ave 2019 (TMC-019)	4							
35th St	4	EB	0	0	0	0	0	
35th St	4	WB	0	0	-6	0	0	
3rd Ave	4	NB	0	-2	9	0	0	
	4	SB	0	0	0	0	0	1
34th St & 2nd Ave 2019 (TMC-020)	5							
34th St	5	EB	0	0	13	1	0	
34th St	5	WB	0	0	-13	0	0	
2nd Ave	5	NB	0	0	0	0	0	
2nd Ave	5	SB	0	-1	-23	0	0	-23
35th St & 2nd Ave 2019 (TMC-021)	6							
35th St	6	EB	0	0	0	2	0	
35th St	6	WB	0	-4	-4	0	0	
2nd Ave	6	NB	0	0	0	0	0	
2nd Ave	6	SB	0	0	-22	0	0	-28

CBD Tolling
QMT - Traffic Flowmap
LN No-Action Increment



- Legend:**
- 1 - Intersection (2019 Collected Data)
 - 7 - Intersection (Uncollected Data)
 - 100 - ATR Volume
 - 100 - Approach Volume

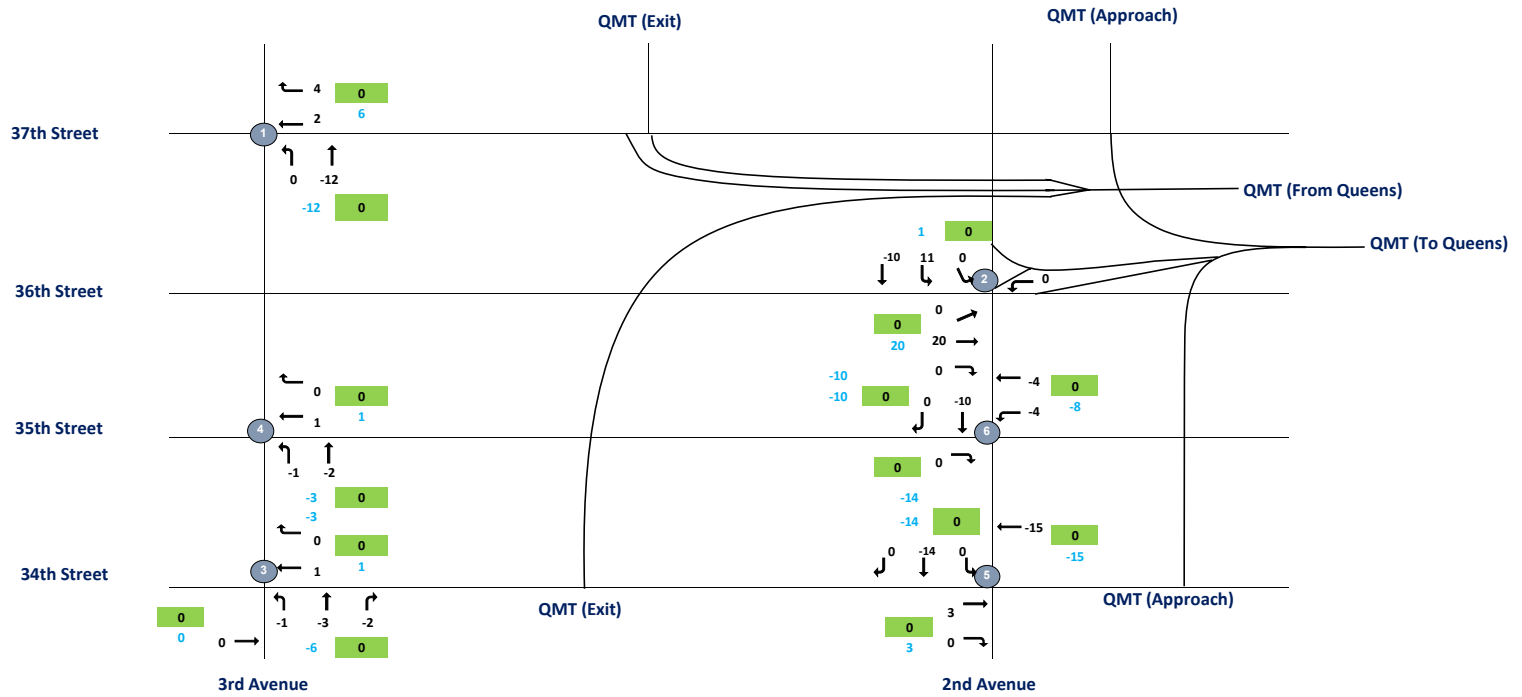

QM

9:00:00 PM

Intersection	Node	Approach	Balanced No-Action Increment					
			Inbound/Outbound					
			LN Peak Hour					
			L2	L	T	R	R2	Total
37th St & 3rd Ave 2019 (TMC-016)	1							
37th St	1	EB	0	0	0	0	0	
37th St	1	WB	0	0	2	4	0	
3rd Ave	1	NB	0	0	-12	0	0	
3rd Ave	1	SB	0	0	0	0	0	-6
36th St & 2nd Ave 2019 (TMC-017)	2							
36th St	2	EB	0	0	20	0	0	
36th St	2	WB	0	0	0	0	0	
2nd Ave	2	NB	0	0	0	0	0	
2nd Ave	2	SB	0	11	-10	0	0	21
34th St & 3rd Ave 2019 (TMC-018)	3							
34th St	3	EB	0	0	0	0	0	
34th St	3	WB	0	0	1	0	0	
3rd Ave	3	NB	0	-1	-3	-2	0	
	3	SB	0	0	0	0	0	-5
35th St & 3rd Ave 2019 (TMC-019)	4							
35th St	4	EB	0	0	0	0	0	
35th St	4	WB	0	0	1	0	0	
3rd Ave	4	NB	0	-1	-2	0	0	
	4	SB	0	0	0	0	0	-2
34th St & 2nd Ave 2019 (TMC-020)	5							
34th St	5	EB	0	0	3	0	0	
34th St	5	WB	0	0	-15	0	0	
2nd Ave	5	NB	0	0	0	0	0	
2nd Ave	5	SB	0	0	-14	0	0	-26
35th St & 2nd Ave 2019 (TMC-021)	6							
35th St	6	EB	0	0	0	0	0	
35th St	6	WB	0	-4	-4	0	0	
2nd Ave	6	NB	0	0	0	0	0	
2nd Ave	6	SB	0	0	-10	0	0	-18

CBD Tolling
RKB - Traffic Flowmap
AM No-Action Increment



- Legend:**
- 1 - Intersection (2019 Collected Data)
 - 7 - Intersection (Uncollected Data)
 - 100 - ATR Volume
 - 100 - Approach Volume

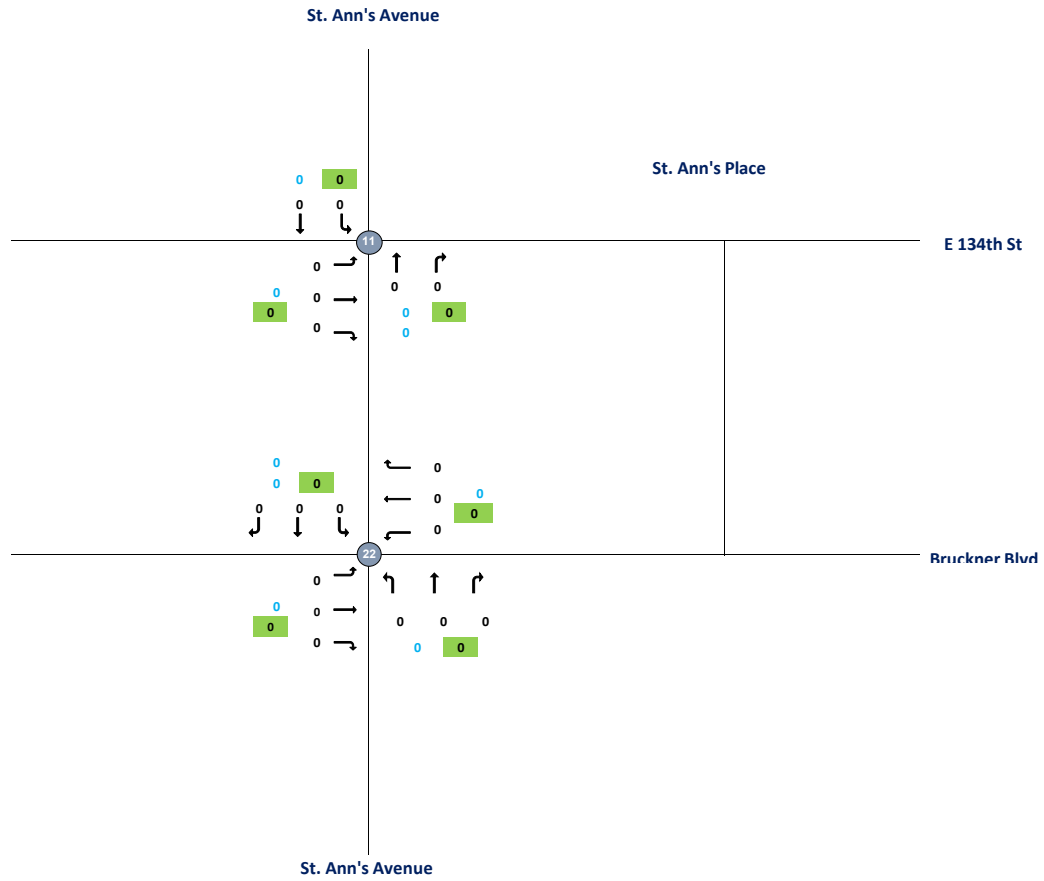

RKB

8:00 AM

Intersection	Node	Approach	Total Vehicles						
			Inbound/Outbound						
			AM Peak Hour						
			L2	L	T	R	R2	Total	
E 134th Street and St. Ann's Ave 2019 (TMC-060)	11								
E 134th Street	11	EB	0	0	0	0	0		
E 134th Street	11	WB	0	0	0	0	0		
St. Ann's Ave	11	NB	0	0	0	0	0		
St. Ann's Ave	11	SB	0	0	0	0	0	0	
Bruckner Blvd and St. Ann's Ave 2019 (TMC-061)	22								
Bruckner Blvd	22	EB	0	0	0	0	0		
Bruckner Blvd	22	WB	0	0	0	0	0		
St. Ann's Ave	22	NB	0	0	0	0	0		
St. Ann's Ave	22	SB	0	0	0	0	0	0	

CBD Tolling
AS - Traffic Flowmap
AM No-Action Increment



- Legend:**
- 1 - Intersection (2019 Collected Data)
 - 7 - Intersection (Uncollected Data)
 - 100 - ATR Volume
 - 100 - Approach Volume

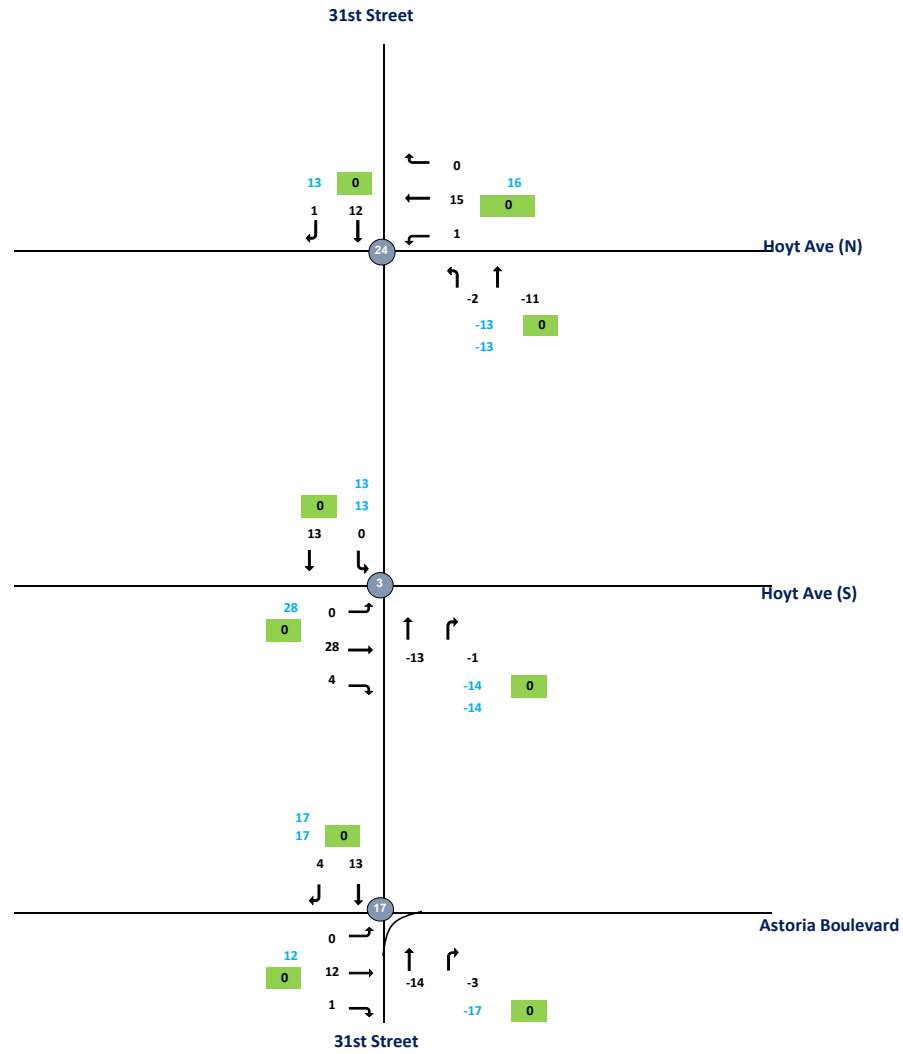

AS

7:15:00 AM

Intersection	Node	Approach	Total Vehicles						
			Inbound/Outbound						
			AM Peak Hour						
			L2	L	T	R	R2	Total	
31st Street and Astoria Blvd 2019 (TMC-062)	17								
Astoria Blvd	17	EB	0	0	12	1	0		
Astoria Blvd	17	WB	0	0	0	0	0		
31st Street	17	NB	0	0	-14	-3	0		
31st Street	17	SB	0	0	13	4	0		13
31st Street and Hoyt Ave N 2019 (TMC-063)	24								
Hoyt Ave N	24	EB	0	0	0	0	0		
Hoyt Ave N	24	WB	0	1	15	0	0		
31st Street	24	NB	0	-2	-11	0	0		
31st Street	24	SB	0	0	12	1	0		16
31st Street and Hoyt Ave S 2019 (TMC-064)	3								
Hoyt Ave S	3	EB	0	0	28	4	0		
	3		0	0	0	0	0		
31st Street	3	NB	0	0	-13	-1	0		
31st Street	3	SB	0	0	13	0	0		31

CBD Tolling
RKM - Traffic Flowmap
AM No-Action Increment



- Legend:**
- 1 - Intersection (2019 Collected Data)
 - 7 - Intersection (Uncollected Data)
 - 100 - ATR Volume
 - 100 - Approach Volume

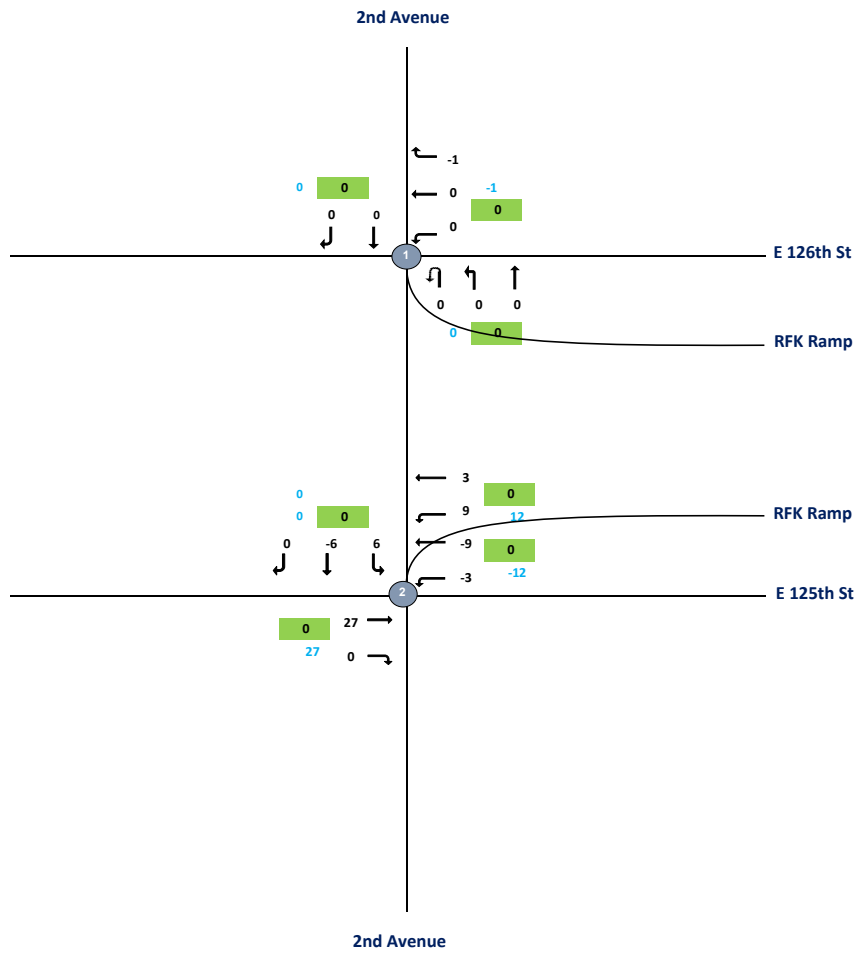

RKM

7:45 AM

Intersection	Node	Approach	Total Vehicles					Total
			Inbound/Outbound					
			AM Peak Hour					
			L2	L	T	R	R2	
E 126th Street and 2nd Ave								
2019 (TMC-058)								
RFK Ramp	1	NW	0	0	0	0	0	
E 126th Street	1	EB	0	0	0	0	0	
E 126th Street	1	WB	0	0	0	-1	0	
2nd Ave	1	NB	0	0	0	0	0	
2nd Ave	1	SB	0	0	0	0	0	-1
E 125th Street and 2nd Ave								
2019 (TMC-059)								
E 125th Street	2	EB	0	0	27	0	0	
E 125th Street	2	WB	0	-3	-9	0	0	
2nd Ave	2	SW	0	9	0	3	0	
2nd Ave	2	SB	0	6	-6	0	0	27

CBD Tolling
RKB - Traffic Flowmap
MD No-Action Increment



- Legend:**
- ① - Intersection (2019 Collected Data)
 - ⑦ - Intersection (Uncollected Data)
 - 100 - ATR Volume
 - 100 - Approach Volume

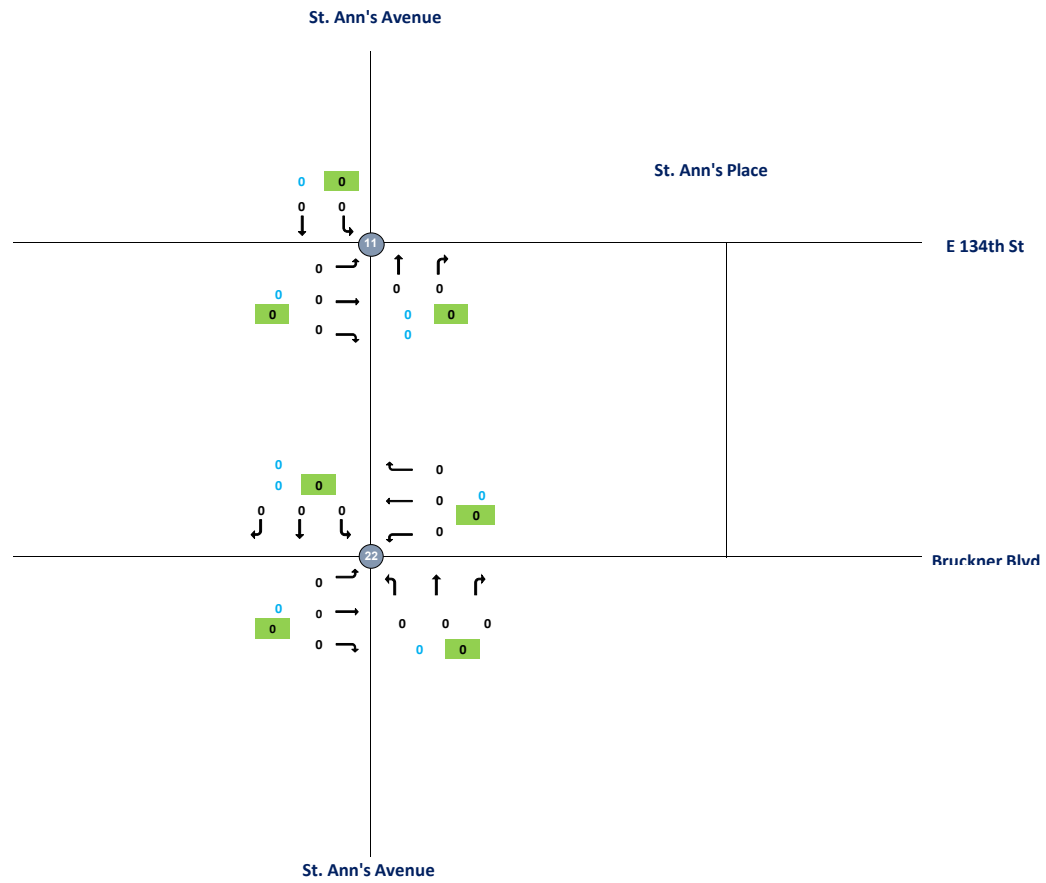

RKB

1:00 PM

Intersection	Node	Approach	Total Vehicles						
			Inbound/Outbound						
			MD Peak Hour						
			L2	L	T	R	R2	Total	
E 134th Street and St. Ann's Ave 2019 (TMC-060)	11								
E 134th Street	11	EB	0	0	0	0	0		
E 134th Street	11	WB	0	0	0	0	0		
St. Ann's Ave	11	NB	0	0	0	0	0		
St. Ann's Ave	11	SB	0	0	0	0	0		0
Bruckner Blvd and St. Ann's Ave 2019 (TMC-061)	22								
Bruckner Blvd	22	EB	0	0	0	0	0		
Bruckner Blvd	22	WB	0	0	0	0	0		
St. Ann's Ave	22	NB	0	0	0	0	0		
St. Ann's Ave	22	SB	0	0	0	0	0		0

CBD Tolling
AS - Traffic Flowmap
MD No-Action Increment



- Legend:**
- 1 - Intersection (2019 Collected Data)
 - 7 - Intersection (Uncollected Data)
 - 100 - ATR Volume
 - 100 - Approach Volume

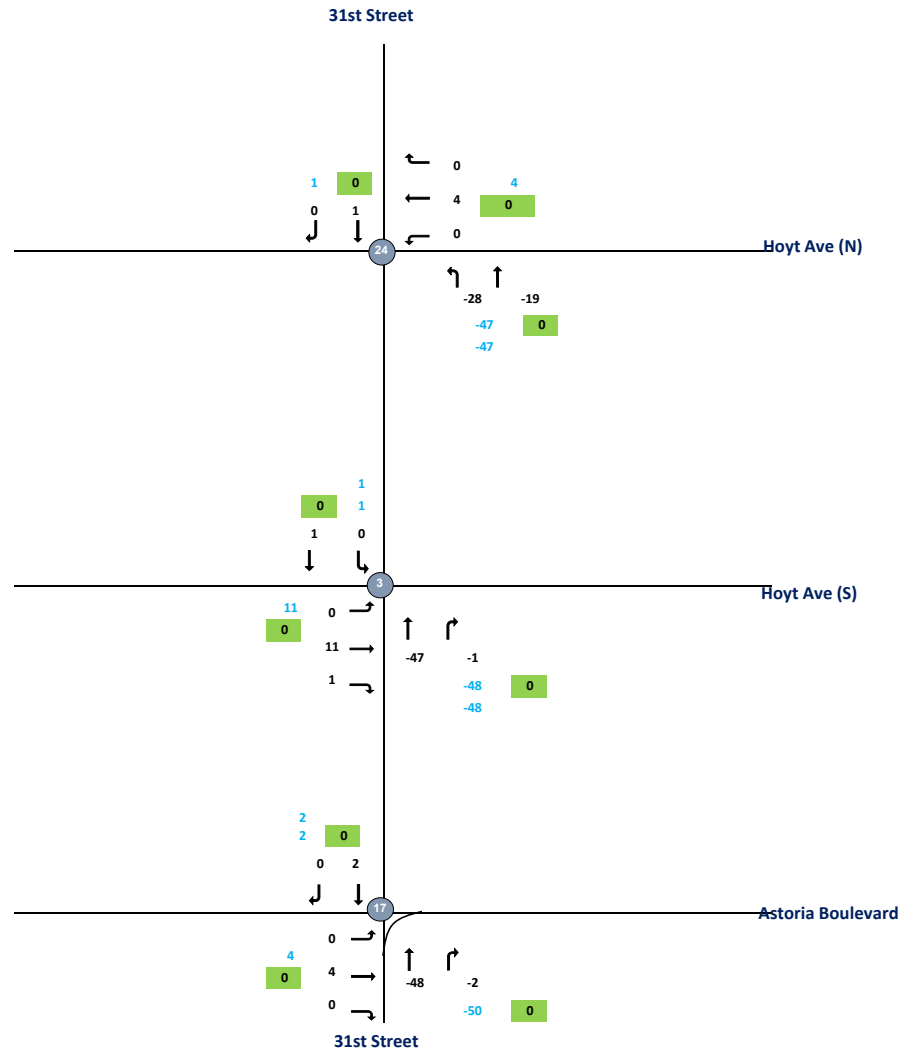

AS

12:30:00 PM

Intersection	Node	Approach	Total Vehicles						
			Inbound/Outbound						
			MD Peak Hour						
			L2	L	T	R	R2	Total	
31st Street and Astoria Blvd 2019 (TMC-062)	17								
Astoria Blvd	17	EB	0	0	4	0	0		
Astoria Blvd	17	WB	0	0	0	0	0		
31st Street	17	NB	0	0	-48	-2	0		
31st Street	17	SB	0	0	2	0	0		-44
31st Street and Hoyt Ave N 2019 (TMC-063)	24								
Hoyt Ave N	24	EB	0	0	0	0	0		
Hoyt Ave N	24	WB	0	0	4	0	0		
31st Street	24	NB	0	-28	-19	0	0		
31st Street	24	SB	0	0	1	0	0		-42
31st Street and Hoyt Ave S 2019 (TMC-064)	3								
Hoyt Ave S	3	EB	0	0	11	1	0		
	3		0	0	0	0	0		
31st Street	3	NB	0	0	-47	-1	0		
31st Street	3	SB	0	0	1	0	0		-35

CBD Tolling
RKM - Traffic Flowmap
MD No-Action Increment



- Legend:**
- 1 - Intersection (2019 Collected Data)
 - 7 - Intersection (Uncollected Data)
 - 100 - ATR Volume
 - 100 - Approach Volume

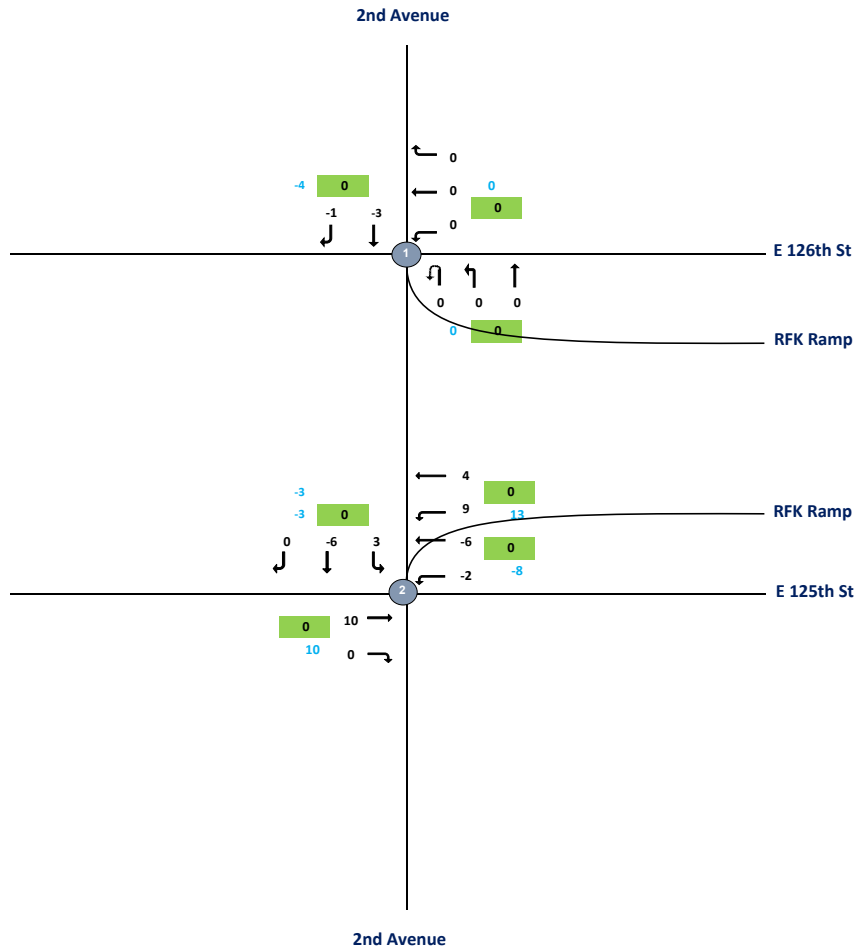

RKM

1:00 PM

Intersection	Node	Approach	Total Vehicles					Total	
			Inbound/Outbound						
			MD Peak Hour						
			L2	L	T	R	R2		
E 126th Street and 2nd Ave 2019 (TMC-058)									
RFK Ramp	1	NW	0	0	0	0	0		
E 126th Street	1	EB	0	0	0	0	0		
E 126th Street	1	WB	0	0	0	0	0		
2nd Ave	1	NB	0	0	0	0	0		
2nd Ave	1	SB	0	0	-3	-1	0	-4	
E 125th Street and 2nd Ave 2019 (TMC-059)	2								
E 125th Street	2	EB	0	0	10	0	0		
E 125th Street	2	WB	0	-2	-6	0	0		
2nd Ave	2	SW	0	9	0	4	0		
2nd Ave	2	SB	0	3	-6	0	0	12	

CBD Tolling
RKB - Traffic Flowmap
PM No-Action Increment



- Legend:**
- 1 - Intersection (2019 Collected Data)
 - 7 - Intersection (Uncollected Data)
 - 100 - ATR Volume
 - 100 - Approach Volume

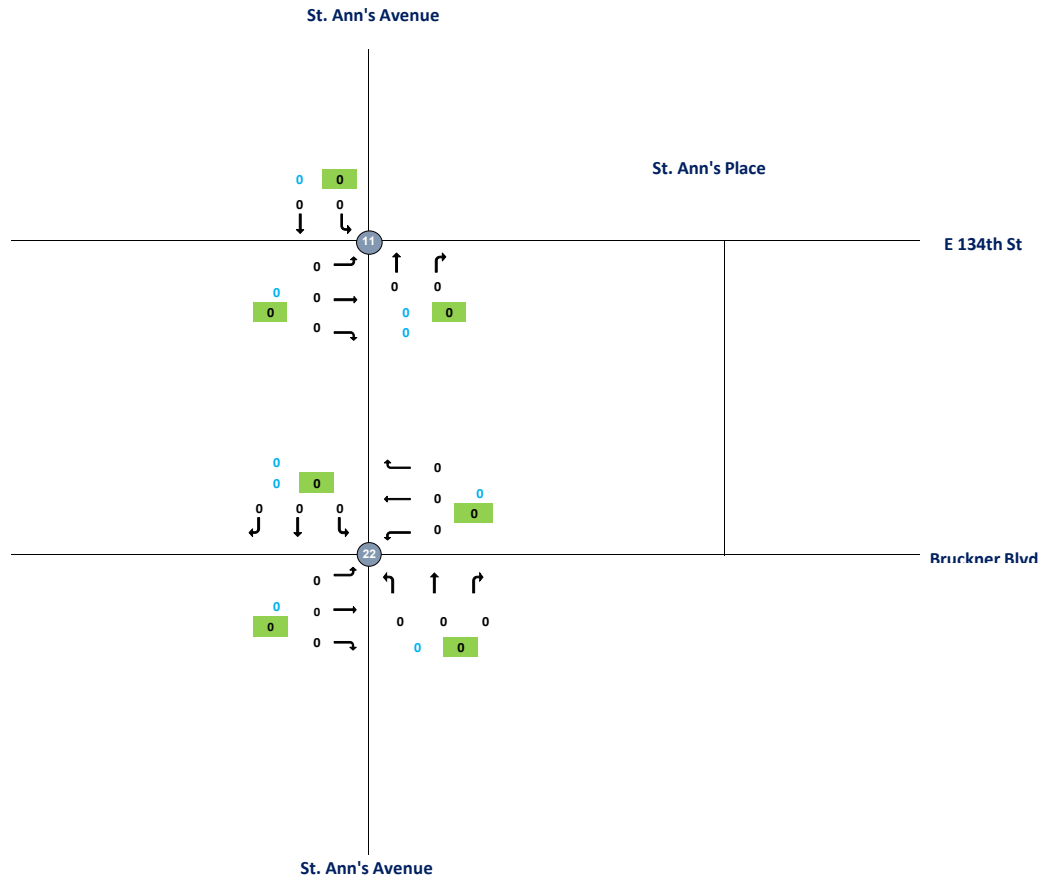

RKB

5:00 PM

Intersection	Node	Approach	Total Vehicles						
			Inbound/Outbound						
			PM Peak Hour						
			L2	L	T	R	R2	Total	
E 134th Street and St. Ann's Ave 2019 (TMC-060)	11								
E 134th Street	11	EB	0	0	0	0	0		
E 134th Street	11	WB	0	0	0	0	0		
St. Ann's Ave	11	NB	0	0	0	0	0		
St. Ann's Ave	11	SB	0	0	0	0	0	0	
Bruckner Blvd and St. Ann's Ave 2019 (TMC-061)	22								
Bruckner Blvd	22	EB	0	0	0	0	0		
Bruckner Blvd	22	WB	0	0	0	0	0		
St. Ann's Ave	22	NB	0	0	0	0	0		
St. Ann's Ave	22	SB	0	0	0	0	0	0	

CBD Tolling
AS - Traffic Flowmap
PM No-Action Increment



- Legend:**
- 1 - Intersection (2019 Collected Data)
 - 7 - Intersection (Uncollected Data)
 - 100 - ATR Volume
 - 100 - Approach Volume

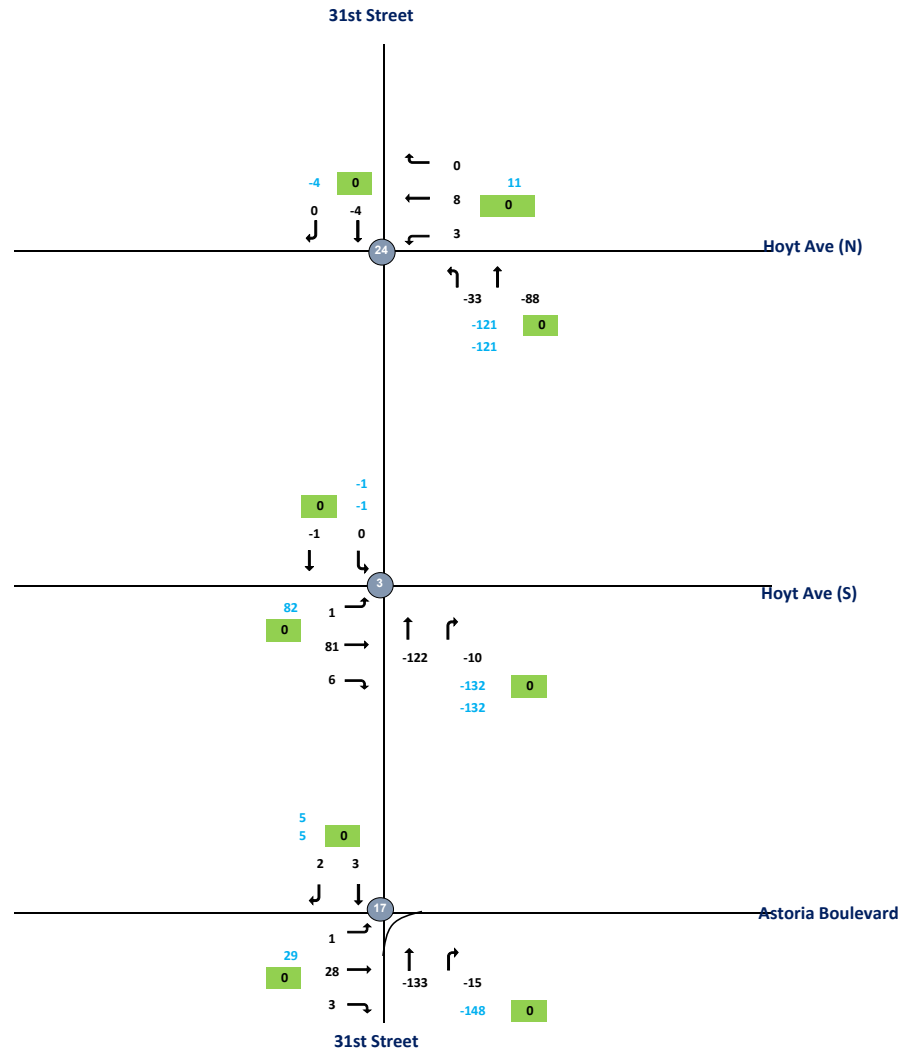

AS

4:00:00 PM

Intersection	Node	Approach	Total Vehicles					
			Inbound/Outbound					
			PM Peak Hour					
			L2	L	T	R	R2	Total
31st Street and Astoria Blvd 2019 (TMC-062)	17							
Astoria Blvd	17	EB	0	1	28	3	0	
Astoria Blvd	17	WB	0	0	0	0	0	
31st Street	17	NB	0	0	-133	-15	0	
31st Street	17	SB	0	0	3	2	0	-111
31st Street and Hoyt Ave N 2019 (TMC-063)	24							
Hoyt Ave N	24	EB	0	0	0	0	0	
Hoyt Ave N	24	WB	0	3	8	0	0	
31st Street	24	NB	0	-33	-88	0	0	
31st Street	24	SB	0	0	-4	0	0	-114
31st Street and Hoyt Ave S 2019 (TMC-064)	3							
Hoyt Ave S	3	EB	0	1	81	6	0	
	3		0	0	0	0	0	
31st Street	3	NB	0	0	-122	-10	0	
31st Street	3	SB	0	0	-1	0	0	-45

CBD Tolling
RKM - Traffic Flowmap
PM No-Action Increment



- Legend:**
- 1 - Intersection (2019 Collected Data)
 - 7 - Intersection (Uncollected Data)
 - 100 - ATR Volume
 - 100 - Approach Volume

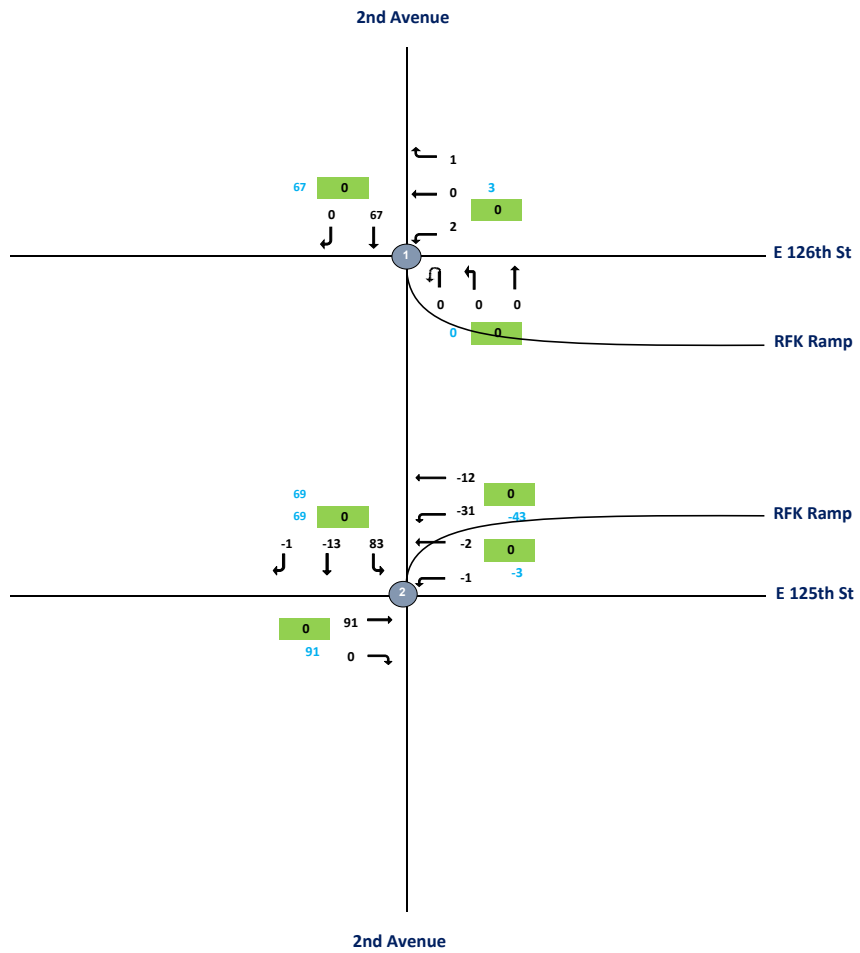





RKM

4:00 PM

Intersection	Node	Approach	Total Vehicles					Total
			Inbound/Outbound					
			PM Peak Hour					
			L2	L	T	R	R2	
E 126th Street and 2nd Ave								
2019 (TMC-058)								
RFK Ramp	1	NW	0	0	0	0	0	
E 126th Street	1	EB	0	0	0	0	0	
E 126th Street	1	WB	0	2	0	1	0	
2nd Ave	1	NB	0	0	0	0	0	
2nd Ave	1	SB	0	0	67	0	0	70
E 125th Street and 2nd Ave								
2019 (TMC-059)								
E 125th Street	2	EB	0	0	91	0	0	
E 125th Street	2	WB	0	-1	-2	0	0	
2nd Ave	2	SW	0	-31	0	-12	0	
2nd Ave	2	SB	0	83	-13	-1	0	114

CBD Tolling
RKB - Traffic Flowmap
LN No-Action Increment



- Legend:**
-  - Intersection (2019 Collected Data)
 -  - Intersection (Uncollected Data)
 -  - ATR Volume
 -  - Approach Volume

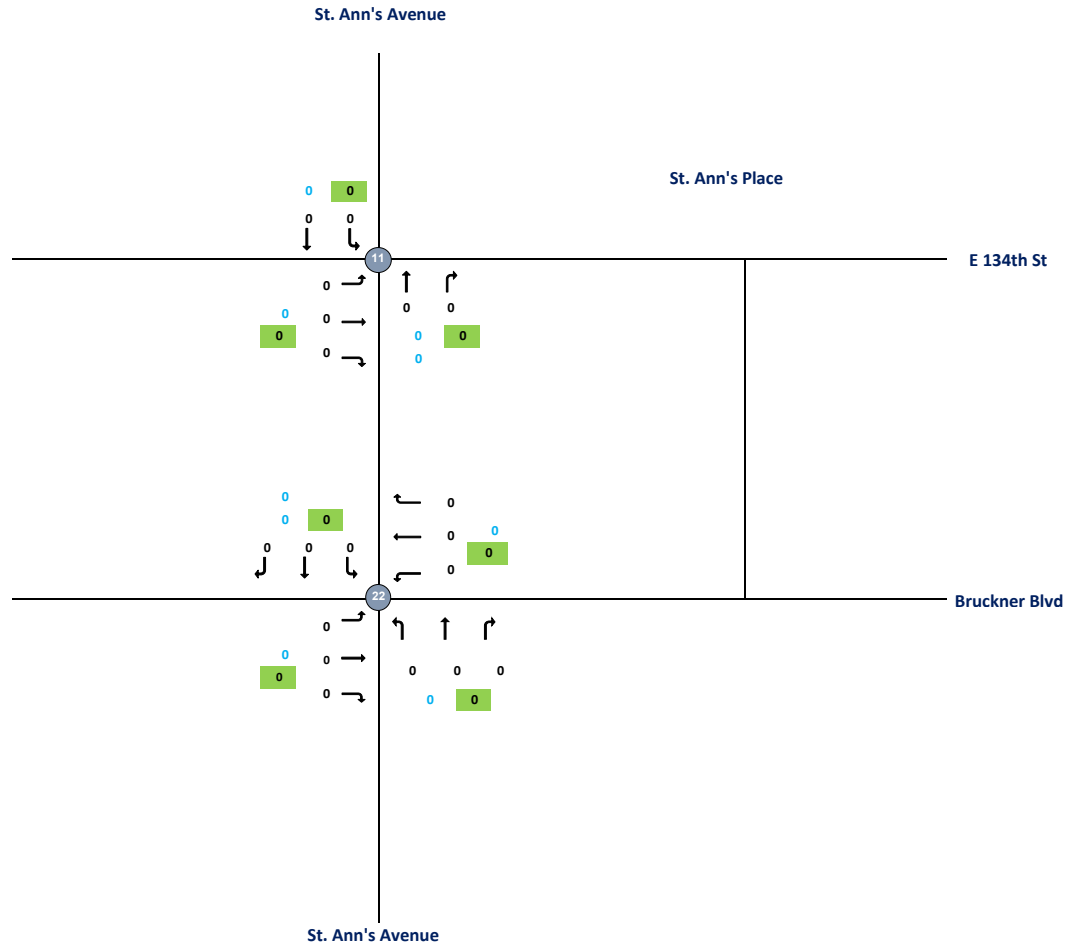

RKB

9:00 PM

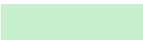

Intersection	Node	Approach	Total Vehicles						
			Inbound/Outbound						
			LN Peak Hour						
			L2	L	T	R	R2	Total	
E 134th Street and St. Ann's Ave 2019 (TMC-060)	11								
E 134th Street	11	EB	0	0	0	0	0		
E 134th Street	11	WB	0	0	0	0	0		
St. Ann's Ave	11	NB	0	0	0	0	0		
St. Ann's Ave	11	SB	0	0	0	0	0		0
Bruckner Blvd and St. Ann's Ave 2019 (TMC-061)	22								
Bruckner Blvd	22	EB	0	0	0	0	0		
Bruckner Blvd	22	WB	0	0	0	0	0		
St. Ann's Ave	22	NB	0	0	0	0	0		
St. Ann's Ave	22	SB	0	0	0	0	0		0

CBD Tolling
AS - Traffic Flowmap
LN No-Action Increment



- Legend:**
- 1 - Intersection (2019 Collected Data)
 - 7 - Intersection (Uncollected Data)
 - 100 - ATR Volume
 - 100 - Approach Volume

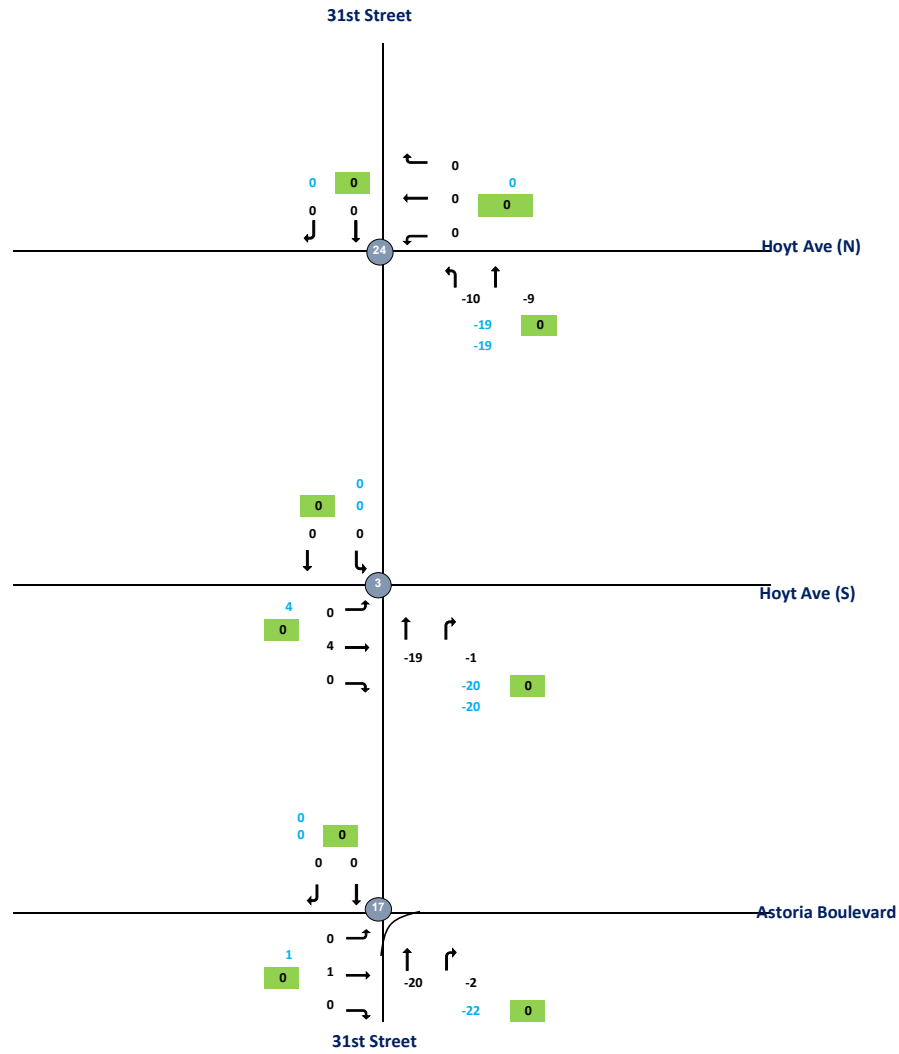

AS

9:45:00 PM

Intersection	Node	Approach	Total Vehicles						
			Inbound/Outbound						
			LN Peak Hour						
			L2	L	T	R	R2	Total	
31st Street and Astoria Blvd 2019 (TMC-062)	17								
Astoria Blvd	17	EB	0	0	1	0	0		
Astoria Blvd	17	WB	0	0	0	0	0		
31st Street	17	NB	0	0	-20	-2	0		
31st Street	17	SB	0	0	0	0	0		-21
31st Street and Hoyt Ave N 2019 (TMC-063)	24								
Hoyt Ave N	24	EB	0	0	0	0	0		
Hoyt Ave N	24	WB	0	0	0	0	0		
31st Street	24	NB	0	-10	-9	0	0		
31st Street	24	SB	0	0	0	0	0		-19
31st Street and Hoyt Ave S 2019 (TMC-064)	3								
Hoyt Ave S	3	EB	0	0	4	0	0		
	3		0	0	0	0	0		
31st Street	3	NB	0	0	-19	-1	0		
31st Street	3	SB	0	0	0	0	0		-16

CBD Tolling
RKM - Traffic Flowmap
LN No-Action Increment



- Legend:**
- 1 - Intersection (2019 Collected Data)
 - 2 - Intersection (Uncollected Data)
 - 100 - ATR Volume
 - 100 - Approach Volume

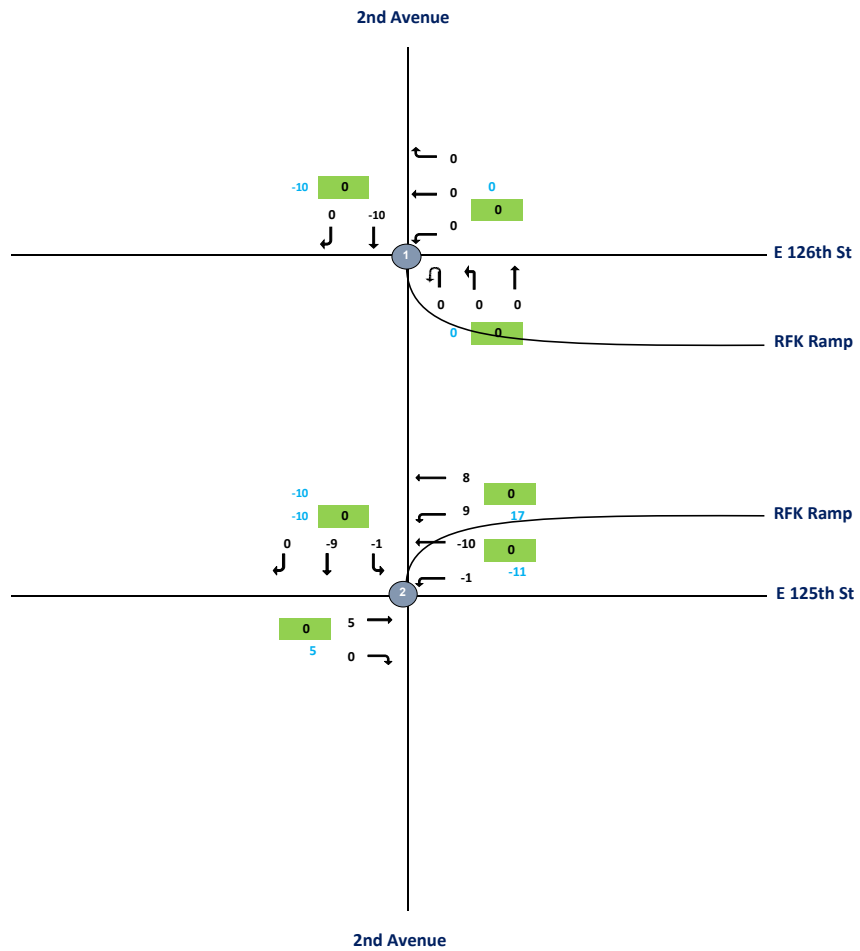

RKM

9:45 PM

Intersection	Node	Approach	Total Vehicles						
			Inbound/Outbound						
			LN Peak Hour						
			L2	L	T	R	R2	Total	
E 126th Street and 2nd Ave 2019 (TMC-058)									
RFK Ramp	1	NW	0	0	0	0	0		
E 126th Street	1	EB	0	0	0	0	0		
E 126th Street	1	WB	0	0	0	0	0		
2nd Ave	1	NB	0	0	0	0	0		
2nd Ave	1	SB	0	0	-10	0	0	-10	
E 125th Street and 2nd Ave 2019 (TMC-059)									
E 125th Street	2	EB	0	0	5	0	0		
E 125th Street	2	WB	0	-1	-10	0	0		
2nd Ave	2	SW	0	9	0	8	0		
2nd Ave	2	SB	0	-1	-9	0	0	1	

CBD Tolling
Red Hook- Traffic Flowmap
AM No-Action Increment



- Legend:**
- 1 - Intersection (2019 Collected Data)
 - 7 - Intersection (Uncollected Data)
 - 100 - ATR Volume
 - 100 - Approach Volume

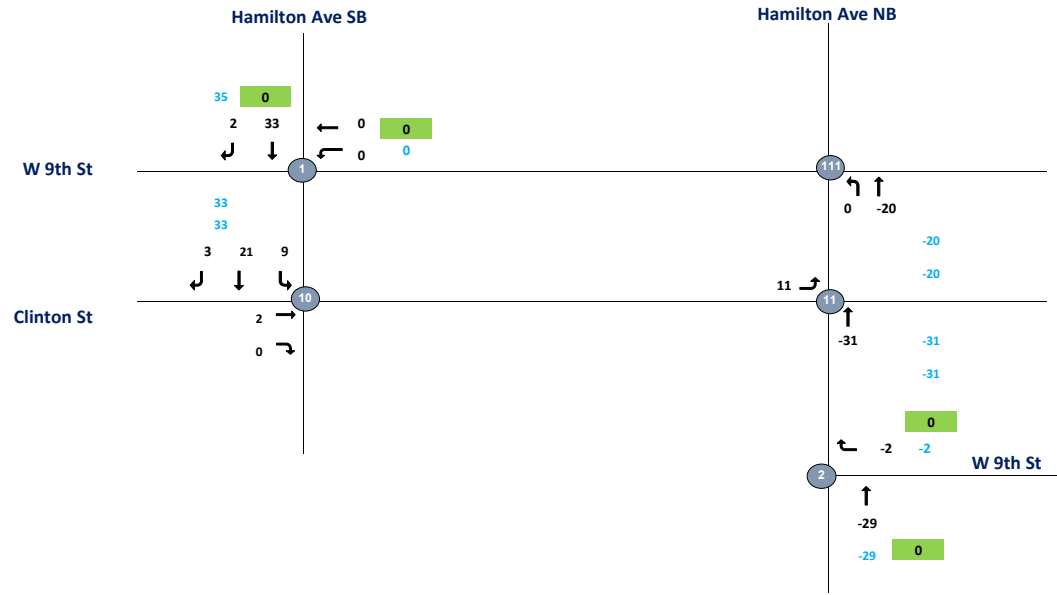

RH

7:45:00 AM

Intersection	Node	Approach	Balanced With-Action Increment					
			Inbound/Outbound					Total
			L2	L	T	R	R2	
Hamilton Ave SB & W 9th St 2019 (TMC-040)	1							
W 9th St	1	EB	0	0	0	0	0	
W 9th St	1	WB	0	0	0	0	0	
Hamilton Ave SB	1		0	0	0	0	0	
Hamilton Ave SB	1	SB	0	0	33	2	0	35
Hamilton Ave SB & W 9th St 2019 (TMC-040)	10							
Clinton Avenue	10	EB	0	0	2	0	0	
Clinton Avenue	10	WB	0	0	0	0	0	
Hamilton Ave SB	10		0	0	0	0	0	
Hamilton Ave SB	10	SB	0	9	21	3	0	35
Hamilton Ave SB & W 9th St 2019 (TMC-040)	11							
Clinton Avenue	11	EB	0	11	0	0	0	
Clinton Avenue	11		0	0	0	0	0	
Hamilton Ave	11	NB	0	0	-31	0	0	
Hamilton Ave	11		0	0	0	0	0	-20
Hamilton Ave SB & W 9th St 2019 (TMC-040)	111							
W 9th St	111	EB	0	0	0	0	0	
W 9th St	111	WB	0	0	0	0	0	
Hamilton Ave	111	NB	0	0	-20	0	0	
-	111	SB	0	0	0	0	0	-20
Hamilton Ave NB & W 9th St 2019 (TMC-041)	2							
W 9th St	2	EB	0	0	0	0	0	
W 9th St	2	WB	0	0	0	-2	0	
Hamilton Ave	2	NB	0	0	-29	0	0	
Hamilton Ave	2	SB	0	0	0	0	0	-31

CBD Tolling
Red Hook- Traffic Flowmap
MD No-Action Increment



- Legend:**
- 1 - Intersection (2019 Collected Data)
 - 7 - Intersection (Uncollected Data)
 - 100 - ATR Volume
 - 100 - Approach Volume

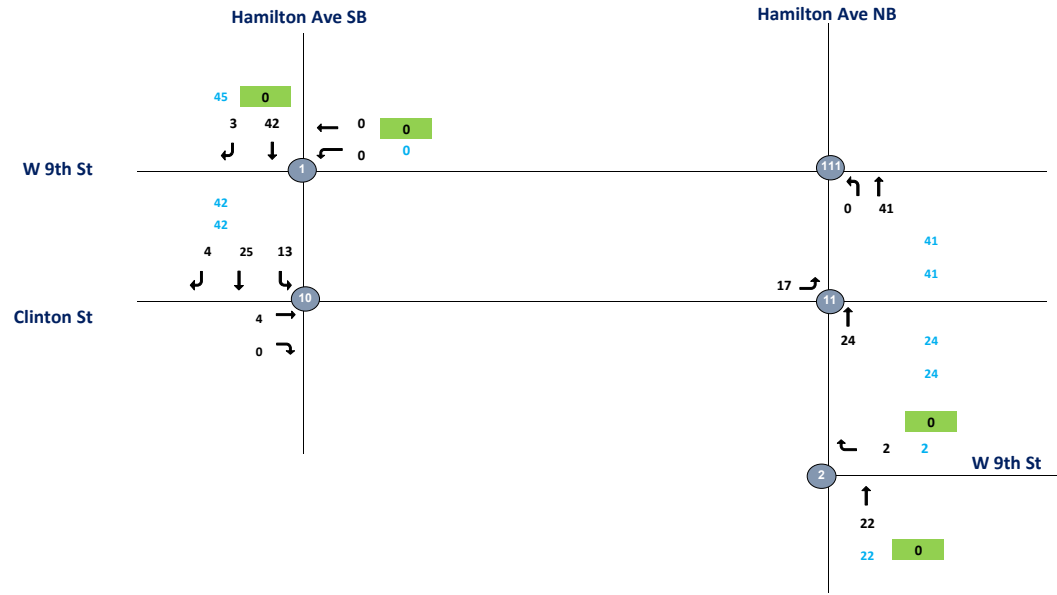

RH

12:00:00 PM

Intersection	Node	Approach	Balanced With-Action Increment					
			Inbound/Outbound					Total
			MD Peak Hour					
L2	L	T	R	R2				
Hamilton Ave SB & W 9th St 2019 (TMC-040)	1							
W 9th St	1	EB	0	0	0	0	0	
W 9th St	1	WB	0	0	0	0	0	
Hamilton Ave SB	1		0	0	0	0	0	
Hamilton Ave SB	1	SB	0	0	42	3	0	45
Hamilton Ave SB & W 9th St 2019 (TMC-040)	10							
Clinton Avenue	10	EB	0	0	4	0	0	
Clinton Avenue	10	WB	0	0	0	0	0	
Hamilton Ave SB	10		0	0	0	0	0	
Hamilton Ave SB	10	SB	0	13	25	4	0	46
Hamilton Ave SB & W 9th St 2019 (TMC-040)	11							
Clinton Avenue	11	EB	0	17	0	0	0	
Clinton Avenue	11		0	0	0	0	0	
Hamilton Ave	11	NB	0	0	24	0	0	
Hamilton Ave	11		0	0	0	0	0	41
Hamilton Ave SB & W 9th St 2019 (TMC-040)	111							
W 9th St	111	EB	0	0	0	0	0	
W 9th St	111	WB	0	0	0	0	0	
Hamilton Ave	111	NB	0	0	41	0	0	
-	111	SB	0	0	0	0	0	41
Hamilton Ave NB & W 9th St 2019 (TMC-041)	2							
W 9th St	2	EB	0	0	0	0	0	
W 9th St	2	WB	0	0	0	2	0	
Hamilton Ave	2	NB	0	0	22	0	0	
Hamilton Ave	2	SB	0	0	0	0	0	24

CBD Tolling
Red Hook- Traffic Flowmap
PM No-Action Increment



- Legend:**
- 1 - Intersection (2019 Collected Data)
 - 7 - Intersection (Uncollected Data)
 - 100 - ATR Volume
 - 100 - Approach Volume

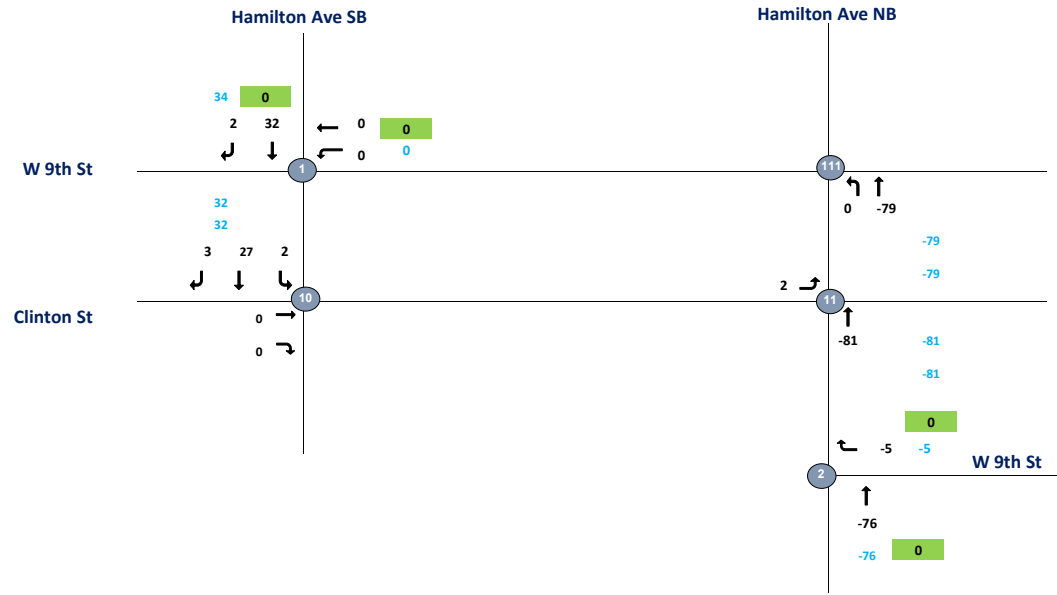

RH

4:00:00 PM

Intersection	Node	Approach	Balanced With-Action Increment						
			Inbound/Outbound					Total	
			PM Peak Hour						
			L2	L	T	R	R2		
Hamilton Ave SB & W 9th St 2019 (TMC-040)	1								
W 9th St	1	EB	0	0	0	0	0		
W 9th St	1	WB	0	0	0	0	0		
Hamilton Ave SB	1		0	0	0	0	0		
Hamilton Ave SB	1	SB	0	0	32	2	0		34
Hamilton Ave SB & W 9th St 2019 (TMC-040)	10								
Clinton Avenue	10	EB	0	0	0	0	0		
Clinton Avenue	10	WB	0	0	0	0	0		
Hamilton Ave SB	10		0	0	0	0	0		
Hamilton Ave SB	10	SB	0	2	27	3	0		32
Hamilton Ave SB & W 9th St 2019 (TMC-040)	11								
Clinton Avenue	11	EB	0	2	0	0	0		
Clinton Avenue	11		0	0	0	0	0		
Hamilton Ave	11	NB	0	0	-81	0	0		
Hamilton Ave	11		0	0	0	0	0		-79
Hamilton Ave SB & W 9th St 2019 (TMC-040)	111								
W 9th St	111	EB	0	0	0	0	0		
W 9th St	111	WB	0	0	0	0	0		
Hamilton Ave	111	NB	0	0	-79	0	0		
-	111	SB	0	0	0	0	0		-79
Hamilton Ave NB & W 9th St 2019 (TMC-041)	2								
W 9th St	2	EB	0	0	0	0	0		
W 9th St	2	WB	0	0	0	-5	0		
Hamilton Ave	2	NB	0	0	-76	0	0		
Hamilton Ave	2	SB	0	0	0	0	0		-81

CBD Tolling
Red Hook- Traffic Flowmap
LN No-Action Increment



- Legend:**
- ① - Intersection (2019 Collected Data)
 - ⑦ - Intersection (Uncollected Data)
 - 100 - ATR Volume
 - 100 - Approach Volume

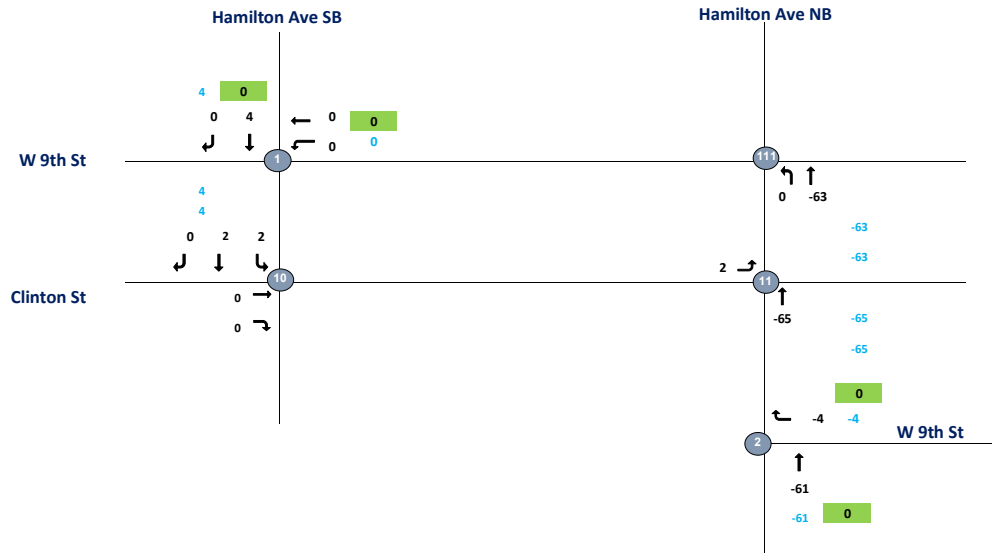

RH

9:00:00 PM

Intersection	Node	Approach	Balanced With-Action Increment					
			Inbound/Outbound					Total
			L2	L	T	R	R2	
Hamilton Ave SB & W 9th St 2019 (TMC-040)	1							
W 9th St	1	EB	0	0	0	0	0	
W 9th St	1	WB	0	0	0	0	0	
Hamilton Ave SB	1		0	0	0	0	0	
Hamilton Ave SB	1	SB	0	0	4	0	0	4
Hamilton Ave SB & W 9th St 2019 (TMC-040)	10							
Clinton Avenue	10	EB	0	0	0	0	0	
Clinton Avenue	10	WB	0	0	0	0	0	
Hamilton Ave SB	10		0	0	0	0	0	
Hamilton Ave SB	10	SB	0	2	2	0	0	4
Hamilton Ave SB & W 9th St 2019 (TMC-040)	11							
Clinton Avenue	11	EB	0	2	0	0	0	
Clinton Avenue	11		0	0	0	0	0	
Hamilton Ave	11	NB	0	0	-65	0	0	
Hamilton Ave	11		0	0	0	0	0	-63
Hamilton Ave SB & W 9th St 2019 (TMC-040)	111							
W 9th St	111	EB	0	0	0	0	0	
W 9th St	111	WB	0	0	0	0	0	
Hamilton Ave	111	NB	0	0	-63	0	0	
-	111	SB	0	0	0	0	0	-63
Hamilton Ave NB & W 9th St 2019 (TMC-041)	2							
W 9th St	2	EB	0	0	0	0	0	
W 9th St	2	WB	0	0	0	-4	0	
Hamilton Ave	2	NB	0	0	-61	0	0	
Hamilton Ave	2	SB	0	0	0	0	0	-65

CBD Tolling
UE #1 - Traffic Flowmap
AM No-Action Increment



- Legend:**
- 1 - Intersection (2019 Collected Data)
 - 7 - Intersection (Uncollected Data)
 - 100 - ATR Volume
 - 100 - Approach Volume

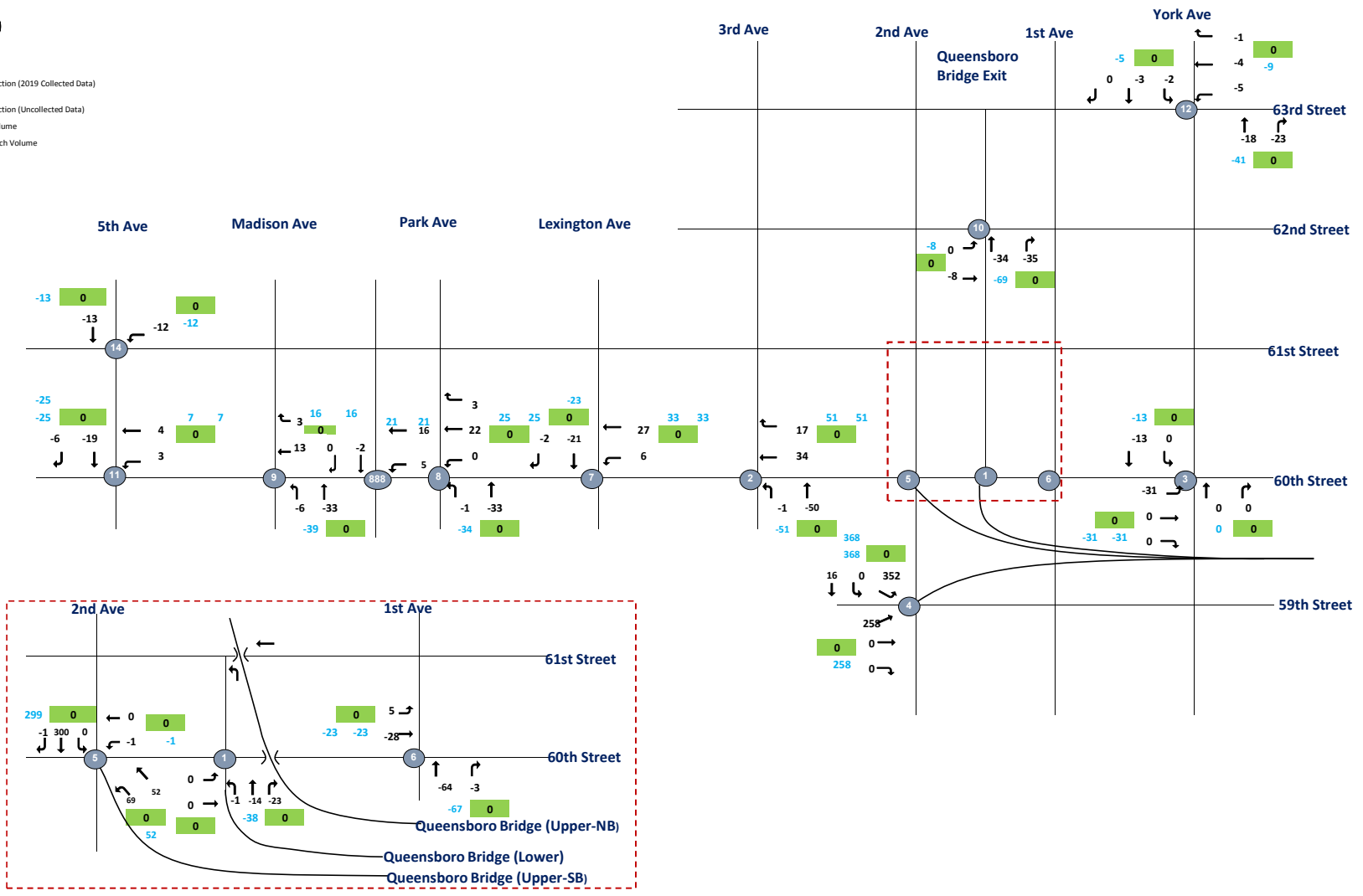

CBD Tolling
UE #2 - Traffic Flowmap
AM No-Action Increment



- Legend:**
- Intersection (2019 Collected Data)
 - Intersection (Uncollected Data)
 - 100 - ATR Volume
 - 100 - Approach Volume

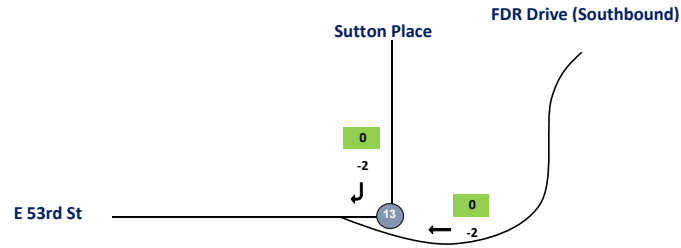

CBD Tolling
UE #3 - Traffic Flowmap
AM No-Action Increment



- Legend:**
- 1 - Intersection (2019 Collected Data)
 - 7 - Intersection (Uncollected Data)
 - 100 - ATR Volume
 - 100 - Approach Volume

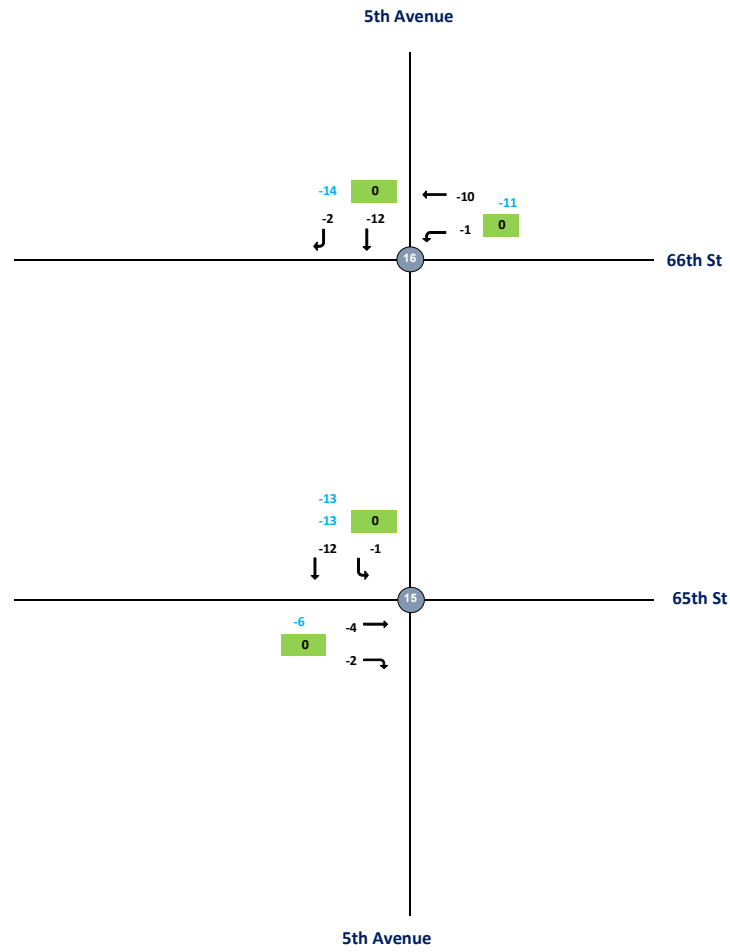

CBD Tolling
UE #3 - Traffic Flowmap
AM No-Action Increment



- Legend:**
- Intersection (2019 Collected Data)
 - Intersection (Uncollected Data)
 - 100 - ATR Volume
 - 100 - Approach Volume

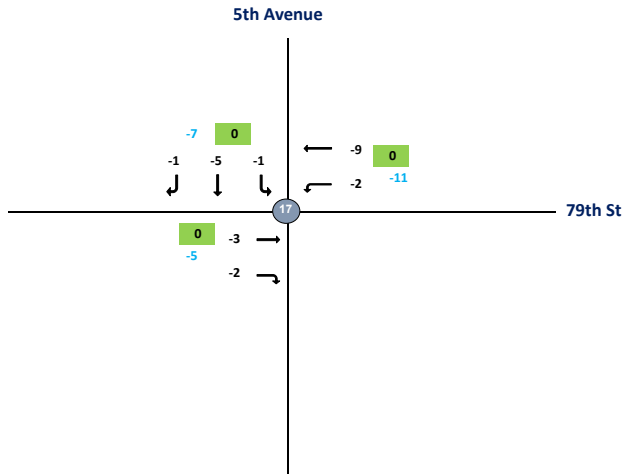

CBD Tolling
UE #4 - Traffic Flowmap
AM No-Action Increment



- Legend:**
- Intersection (2019 Collected Data)
 - Intersection (Uncollected Data)
 - 100 - ATR Volume
 - 100 - Approach Volume

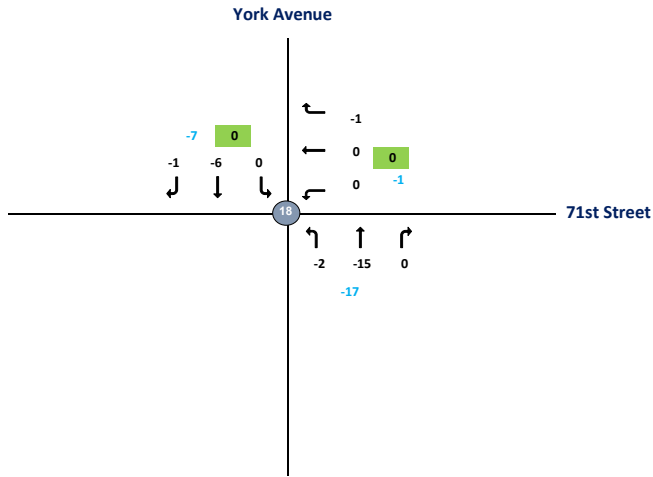

UE

8:00:00 AM

Intersection	Node	Approach	Total Vehicles						
			Inbound/Outbound						
			AM Peak Hour						
			L2	L	T	R	R2	Total	
60th Street & Queensboro Bridge Exit 2019 (TMC-022)	1								
60th Street	1	EB	0	0	0	0	0		
60th Street	1	WB	0	0	0	0	0		
Queensboro Bridge Exit	1	NB	0	-1	-14	-23	0		
	1	SB	0	0	0	0	0	-38	
60th Street & 3rd Ave 2019 (TMC-023)	2								
60th Street	2	EB	0	0	0	0	0		
60th Street	2	WB	0	0	34	17	0		
3rd Ave	2	NB	0	-1	-50	0	0		
	2	SB	0	0	0	0	0	0	
60th St & York Ave 2019 (TMC-024)	3								
60th St	3	EB	0	-31	0	0	0		
60th St	3	WB	0	0	0	0	0		
York Ave	3	NB	0	0	0	0	0		
York Ave	3	SB	0	0	-13	0	0	-44	
59th St & 2nd Ave 2019 (TMC-025)	4								
Queensboro Bridge Exit (SWB)	4								
59th St	4	EB	0	0	258	0	0		
	4	WB	0	0	0	0	0		
	4	NB	0	0	0	0	0		
2nd Ave	4	SB	352	0	16	0	0	626	
60th Street & 2nd Ave 2019 (TMC-026)	5	WB(bridge)							
Queensboro Bridge Exit (NWB)	5	NW	69	52	0	0	0		
60th St	5	EB	0	0	0	0	0		
60th St	5	WB	0	-1	0	0	0		
	5	NB	0	0	0	0	0		
2nd Ave	5	SB	0	0	300	-1	0	298	
60th St & 1st Ave 2019 (TMC-027)	6								
60th Ave	6	EB	0	5	-28	0	0		
	6	WB	0	0	0	0	0		
1st Ave	6	NB	0	0	-64	-3	0		
	6	SB	0	0	0	0	0	-90	

60th St & Lexington Ave 2019 (TMC-028)	7							
	7	EB	0	0	0	0	0	
60th St	7	WB	0	6	27	0	0	
	7	NB	0	0	0	0	0	
Lexington Ave	7	SB	0	0	-21	-2	0	10
60th St & Park Ave 2019 (TMC-029)	8							
	8	EB	0	0	0	0	0	
60th St	8	WB	0	0	22	3	0	
Park Ave	8	NB	0	-1	-33	0	0	
Park Ave	8	SB	0	0	0	0	0	-9
60th St & Park Ave 2019 (TMC-029)	888							
	888	EB	0	0	0	0	0	
60th St	888	WB	0	5	16	0	0	
Park Ave	888	NB	0	0	0	0	0	
Park Ave	888	SB	0	0	-2	0	0	19
60th St & Madison Ave 2019 (TMC-030)	9							
	9	EB	0	0	0	0	0	
60th St	9	WB	0	0	13	3	0	
Madison Ave	9	NB	0	-6	-33	0	0	
	9	SB	0	0	0	0	0	-23
62nd St & Queensboror Bridge Exit 2019 (TMC-031)	10							
62nd St	10	EB	0	0	-8	0	0	
	10	WB	0	0	0	0	0	
Queensboro Bridge Exit	10	NB	0	0	-34	-35	0	
	10	SB	0	0	0	0	0	-77
60th St & 5th Ave 2019 (TMC-032)	11							
	11	EB	0	0	0	0	0	
60th St	11	WB	0	3	4	0	0	
	11	NB	0	0	0	0	0	
5th Ave	11	SB	0	0	-19	-6	0	-18

63rd St & York Ave 2019 (TMC-033)	12							
	12	EB	0	0	0	0	0	
63rd St	12	WB	0	-5	-4	-1	0	
York Ave	12	NB	0	0	-18	-23	0	
York Ave	12	SB	0	-2	-3	0	0	-56
53rd St & FDR Drive 2019 (TMC-034)	13							
	13	EB	0	0	0	0	0	
53rd St	13	SW	0	0	0	-2	0	
	13	NB	0	0	0	0	0	
FDR Drive	13	SB	0	0	0	-2	0	-4
61st St & 5th Ave 2019 (TMC-035)	14							
	14	EB	0	0	0	0	0	
61st St	14	WB	0	-12	0	0	0	
	14	NB	0	0	0	0	0	
5th Ave	14	SB	0	0	-13	0	0	-25
65th St & 5th Ave 2019 (TMC-036)	15							
65th St	15	EB	0	0	-4	-2	0	
	15	WB	0	0	0	0	0	
	15	NB	0	0	0	0	0	
5th Ave	15	SB	0	-1	-12	0	0	-19
66th St & 5th Ave 2019 (TMC-037)	16							
	16	EB	0	0	0	0	0	
66th St	16	WB	0	-1	-10	0	0	
	16	NB	0	0	0	0	0	
5th Ave	16	SB	0	0	-12	-2	0	-25
79th St & 5th Ave 2019 (TMC-038)	17							
79th St	17	EB	0	0	-3	-2	0	
79th St	17	WB	0	-2	-9	0	0	
	17	NB	0	0	0	0	0	
5th Ave	17	SB	0	-1	-5	-1	0	-23
71st St & York Ave 2019 (TMC-039)	18							
	18	EB	0	0	0	0	0	
71st St	18	WB	0	0	0	-1	0	
York Ave	18	NB	0	-2	-15	0	0	
York Ave	18	SB	0	0	-6	-1	0	-25

CBD Tolling
UE #1 - Traffic Flowmap
MD No-Action Increment



- Legend:**
- 1 - Intersection (2019 Collected Data)
 - 7 - Intersection (Uncollected Data)
 - 100 - ATR Volume
 - 100 - Approach Volume

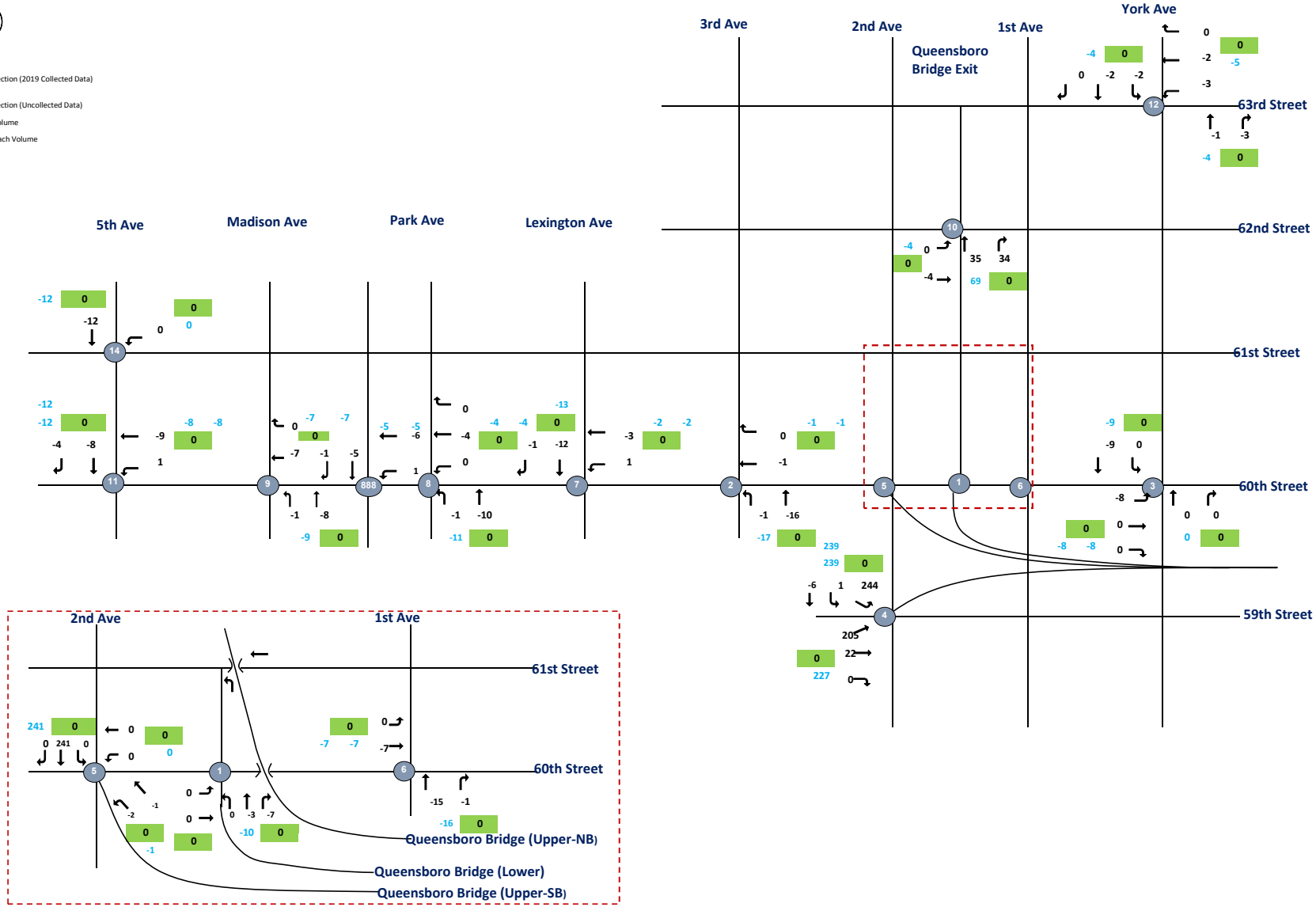

CBD Tolling
UE #2 - Traffic Flowmap
MD No-Action Increment



- Legend:**
- Intersection (2019 Collected Data)
 - Intersection (Uncollected Data)
 - 100 - ATR Volume
 - 100 - Approach Volume

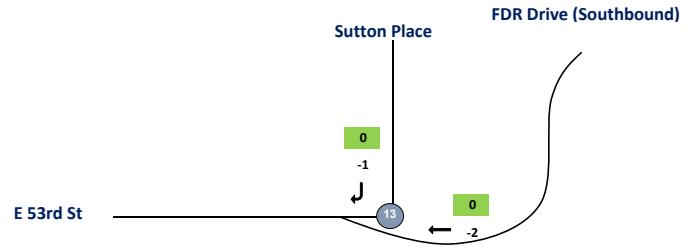

CBD Tolling
UE #3 - Traffic Flowmap
MD No-Action Increment



- Legend:**
- 1 - Intersection (2019 Collected Data)
 - 7 - Intersection (Uncollected Data)
 - 100 - ATR Volume
 - 100 - Approach Volume

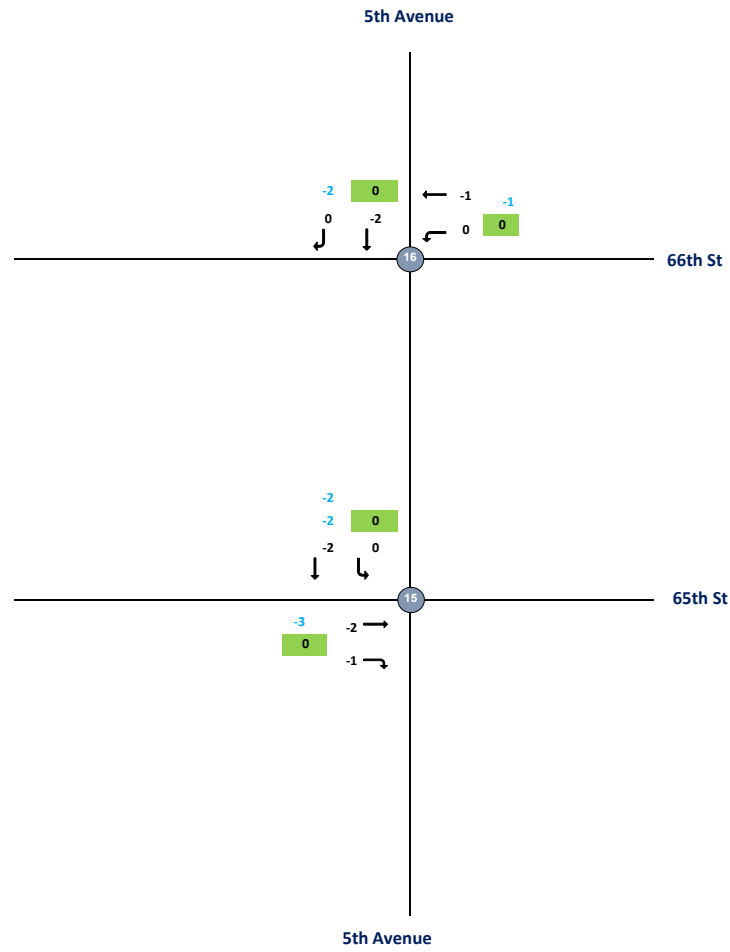

CBD Tolling
UE #3 - Traffic Flowmap
MD No-Action Increment



- Legend:**
- Intersection (2019 Collected Data)
 - Intersection (Uncollected Data)
 - 100** - ATR Volume
 - 100** - Approach Volume

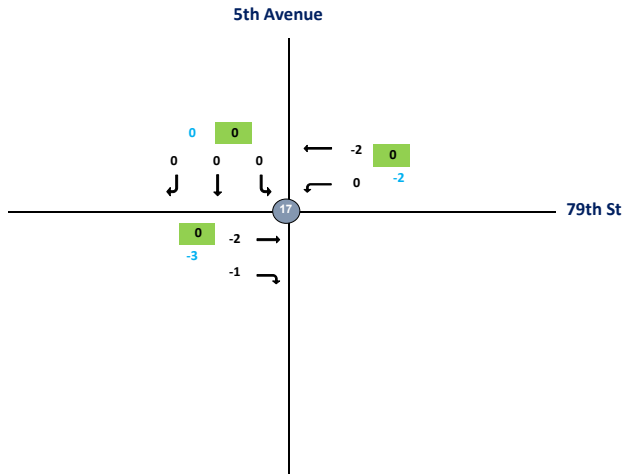

CBD Tolling
UE #4 - Traffic Flowmap
MD No-Action Increment



- Legend:**
- Intersection (2019 Collected Data)
 - Intersection (Uncollected Data)
 - 100 - ATR Volume
 - 100 - Approach Volume

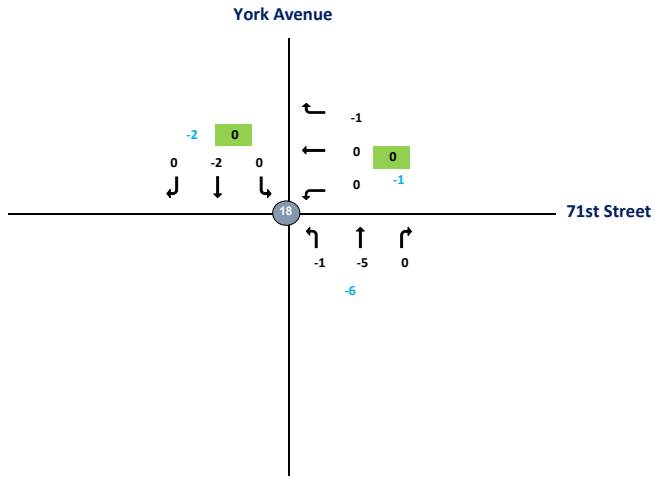

UE

1:00:00 PM

Intersection	Node	Approach	Total Vehicles					
			Inbound/Outbound					
			MD Peak Hour					
			L2	L	T	R	R2	Total
60th Street & Queensboro Bridge Exit 2019 (TMC-022)	1							
60th Street	1	EB	0	0	0	0	0	
60th Street	1	WB	0	0	0	0	0	
Queensboro Bridge Exit	1	NB	0	0	-3	-7	0	
	1	SB	0	0	0	0	0	-10
60th Street & 3rd Ave 2019 (TMC-023)	2							
60th Street	2	EB	0	0	0	0	0	
60th Street	2	WB	0	0	-1	0	0	
3rd Ave	2	NB	0	-1	-16	0	0	
	2	SB	0	0	0	0	0	-18
60th St & York Ave 2019 (TMC-024)	3							
60th St	3	EB	0	-8	0	0	0	
60th St	3	WB	0	0	0	0	0	
York Ave	3	NB	0	0	0	0	0	
York Ave	3	SB	0	0	-9	0	0	-17
59th St & 2nd Ave 2019 (TMC-025)	4							
Queensboro Bridge Exit (SWB)	4	EB	0	0	205	22	0	
59th St	4	WB	0	0	0	0	0	
	4	NB	0	0	0	0	0	
2nd Ave	4	SB	244	1	-6	0	0	466
60th Street & 2nd Ave 2019 (TMC-026)	5	WB(bridge)						
Queensboro Bridge Exit (NWB)	5	NW	-2	-1	0	0	0	
60th St	5	EB	0	0	0	0	0	
60th St	5	WB	0	0	0	0	0	
	5	NB	0	0	0	0	0	
2nd Ave	5	SB	0	0	241	0	0	241
60th St & 1st Ave 2019 (TMC-027)	6							
60th Ave	6	EB	0	0	-7	0	0	
	6	WB	0	0	0	0	0	
1st Ave	6	NB	0	0	-15	-1	0	
	6	SB	0	0	0	0	0	-23

60th St & Lexington Ave 2019 (TMC-028)	7								
	7	EB	0	0	0	0	0		
60th St	7	WB	0	1	-3	0	0		
	7	NB	0	0	0	0	0		
Lexington Ave	7	SB	0	0	-12	-1	0		-15
60th St & Park Ave 2019 (TMC-029)	8								
	8	EB	0	0	0	0	0		
60th St	8	WB	0	0	-4	0	0		
Park Ave	8	NB	0	-1	-10	0	0		
Park Ave	8	SB	0	0	0	0	0		-15
60th St & Park Ave 2019 (TMC-029)	888								
	888	EB	0	0	0	0	0		
60th St	888	WB	0	1	-6	0	0		
Park Ave	888	NB	0	0	0	0	0		
Park Ave	888	SB	0	0	-5	-1	0		-11
60th St & Madison Ave 2019 (TMC-030)	9								
	9	EB	0	0	0	0	0		
60th St	9	WB	0	0	-7	0	0		
Madison Ave	9	NB	0	-1	-8	0	0		
	9	SB	0	0	0	0	0		-16
62nd St & Queensboror Bridge Exit 2019 (TMC-031)	10								
62nd St	10	EB	0	0	-4	0	0		
	10	WB	0	0	0	0	0		
Queensboro Bridge Exit	10	NB	0	0	35	34	0		
	10	SB	0	0	0	0	0		65
60th St & 5th Ave 2019 (TMC-032)	11								
	11	EB	0	0	0	0	0		
60th St	11	WB	0	1	-9	0	0		
	11	NB	0	0	0	0	0		
5th Ave	11	SB	0	0	-8	-4	0		-20

63rd St & York Ave 2019 (TMC-033)	12								
	12	EB	0	0	0	0	0		
63rd St	12	WB	0	-3	-2	0	0		
York Ave	12	NB	0	0	-1	-3	0		
York Ave	12	SB	0	-2	-2	0	0		-13
53rd St & FDR Drive 2019 (TMC-034)	13								
	13	EB	0	0	0	0	0		
53rd St	13	SW	0	0	0	-2	0		
	13	NB	0	0	0	0	0		
FDR Drive	13	SB	0	0	0	-1	0		-3
61st St & 5th Ave 2019 (TMC-035)	14								
	14	EB	0	0	0	0	0		
61st St	14	WB	0	0	0	0	0		
	14	NB	0	0	0	0	0		
5th Ave	14	SB	0	0	-12	0	0		-12
65th St & 5th Ave 2019 (TMC-036)	15								
65th St	15	EB	0	0	-2	-1	0		
	15	WB	0	0	0	0	0		
	15	NB	0	0	0	0	0		
5th Ave	15	SB	0	0	-2	0	0		-5
66th St & 5th Ave 2019 (TMC-037)	16								
	16	EB	0	0	0	0	0		
66th St	16	WB	0	0	-1	0	0		
	16	NB	0	0	0	0	0		
5th Ave	16	SB	0	0	-2	0	0		-3
79th St & 5th Ave 2019 (TMC-038)	17								
79th St	17	EB	0	0	-2	-1	0		
79th St	17	WB	0	0	-2	0	0		
	17	NB	0	0	0	0	0		
5th Ave	17	SB	0	0	0	0	0		-5
71st St & York Ave 2019 (TMC-039)	18								
	18	EB	0	0	0	0	0		
71st St	18	WB	0	0	0	-1	0		
York Ave	18	NB	0	-1	-5	0	0		
York Ave	18	SB	0	0	-2	0	0		-9

CBD Tolling
UE #2 - Traffic Flowmap
PM No-Action Increment



- Legend:**
- Intersection (2019 Collected Data)
 - Intersection (Uncollected Data)
 - 100 - ATR Volume
 - 100 - Approach Volume

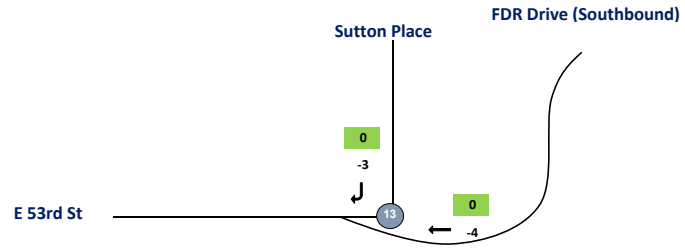

CBD Tolling
UE #3 - Traffic Flowmap
PM No-Action Increment





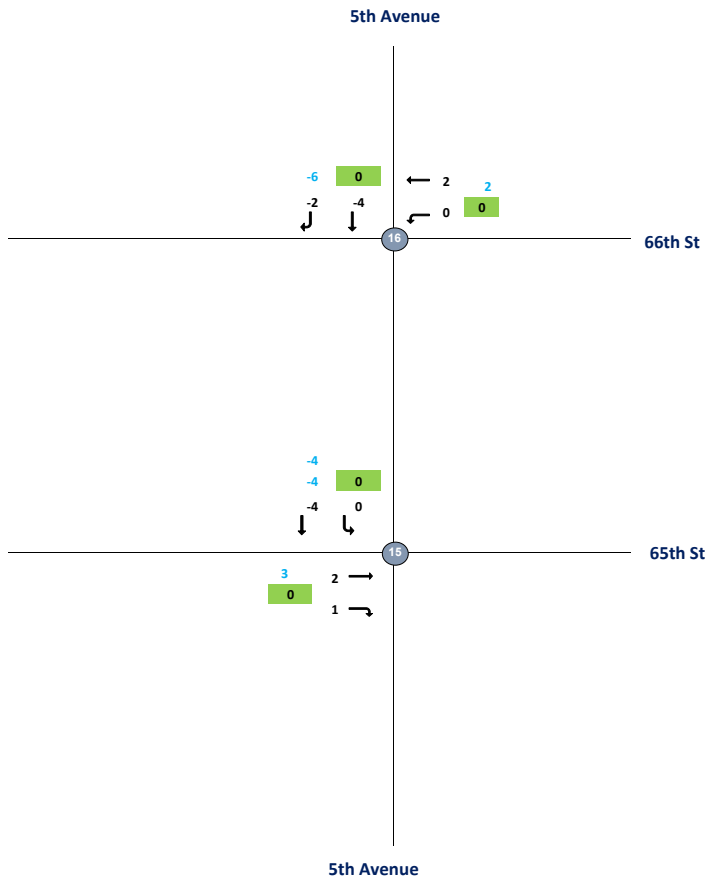

- Legend:**
- 1 - Intersection (2019 Collected Data)
 - 7 - Intersection (Uncollected Data)
 - 100 - ATR Volume
 - 100 - Approach Volume



CBD Tolling
UE #3 - Traffic Flowmap
PM No-Action Increment



- Legend:**
-  - Intersection (2019 Collected Data)
 -  - Intersection (Uncollected Data)
 -  - ATR Volume
 -  - Approach Volume

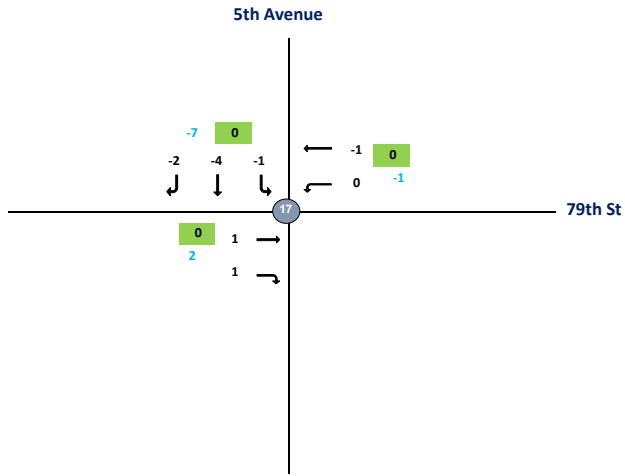

CBD Tolling
UE #4 - Traffic Flowmap
PM No-Action Increment



- Legend:**
- Intersection (2019 Collected Data)
 - 7 - Intersection (Uncollected Data)
 - 100 - ATR Volume
 - 100 - Approach Volume

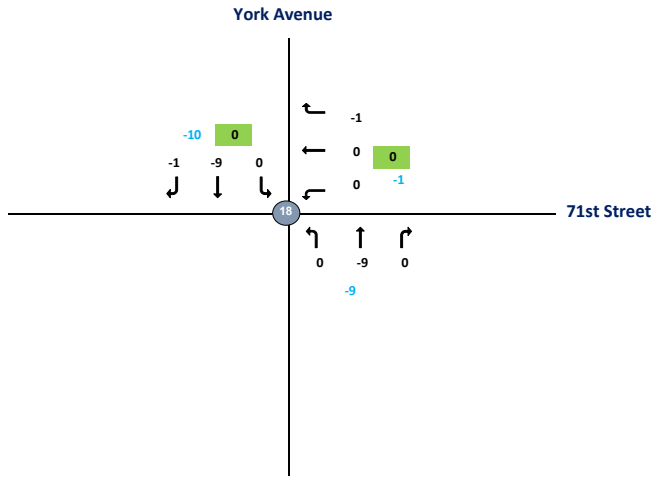

UE

5:00:00 PM

Intersection	Node	Approach	Total Vehicles					
			Inbound/Outbound					Total
			L2	L	T	R	R2	
60th Street & Queensboro Bridge Exit 2019 (TMC-022)	1							
60th Street	1	EB	0	0	0	0	0	
60th Street	1	WB	0	0	0	0	0	
Queensboro Bridge Exit	1	NB	0	0	5	13	0	
	1	SB	0	0	0	0	0	18
60th Street & 3rd Ave 2019 (TMC-023)	2							
60th Street	2	EB	0	0	0	0	0	
60th Street	2	WB	0	0	-19	-3	0	
3rd Ave	2	NB	0	2	17	0	0	
	2	SB	0	0	0	0	0	-3
60th St & York Ave 2019 (TMC-024)	3							
60th St	3	EB	0	0	15	0	0	
60th St	3	WB	0	0	0	0	0	
York Ave	3	NB	0	0	0	0	0	
York Ave	3	SB	0	0	-34	0	0	-19
59th St & 2nd Ave 2019 (TMC-025)	4							
Queensboro Bridge Exit (SWB)	4							
59th St	4	EB	0	0	283	7	-1	
	4	WB	0	0	0	0	0	
	4	NB	0	0	0	0	0	
2nd Ave	4	SB	406	0	-22	0	0	673
60th Street & 2nd Ave 2019 (TMC-026)	5	WB(bridge)						
Queensboro Bridge Exit (NWB)	5	NW	-30	-21	0	0	0	
60th St	5	EB	0	0	0	0	0	
60th St	5	WB	0	0	0	0	0	
	5	NB	0	0	0	0	0	
2nd Ave	5	SB	0	0	414	-1	0	413
60th St & 1st Ave 2019 (TMC-027)	6							
60th Ave	6	EB	0	-2	15	0	0	
	6	WB	0	0	0	0	0	
1st Ave	6	NB	0	0	11	0	0	
	6	SB	0	0	0	0	0	24

60th St & Lexington Ave 2019 (TMC-028)	7								
	7	EB	0	0	0	0	0		
60th St	7	WB	0	-2	-15	0	0		
	7	NB	0	0	0	0	0		
Lexington Ave	7	SB	0	0	-21	-2	0		-40
60th St & Park Ave 2019 (TMC-029)	8								
	8	EB	0	0	0	0	0		
60th St	8	WB	0	0	-17	0	0		
Park Ave	8	NB	0	2	24	0	0		
Park Ave	8	SB	0	0	0	0	0		9
60th St & Park Ave 2019 (TMC-029)	888								
	888	EB	0	0	0	0	0		
60th St	888	WB	0	-1	-14	0	0		
Park Ave	888	NB	0	0	0	0	0		
Park Ave	888	SB	0	0	-9	-1	0		-25
60th St & Madison Ave 2019 (TMC-030)	9								
	9	EB	0	0	0	0	0		
60th St	9	WB	0	0	-14	-1	0		
Madison Ave	9	NB	0	1	11	0	0		
	9	SB	0	0	0	0	0		-3
62nd St & Queensboror Bridge Exit 2019 (TMC-031)	10								
62nd St	10	EB	0	0	0	0	0		
	10	WB	0	0	0	0	0		
Queensboro Bridge Exit	10	NB	0	0	22	46	0		
	10	SB	0	0	0	0	0		68
60th St & 5th Ave 2019 (TMC-032)	11								
	11	EB	0	0	0	0	0		
60th St	11	WB	0	0	-13	0	0		
	11	NB	0	0	0	0	0		
5th Ave	11	SB	0	0	-19	-9	0		-41

63rd St & York Ave 2019 (TMC-033)	12								
	12	EB	0	0	0	0	0		
63rd St	12	WB	0	-12	-4	0	0		
York Ave	12	NB	0	0	-6	-6	0		
York Ave	12	SB	0	-4	-4	0	0		-36
53rd St & FDR Drive 2019 (TMC-034)	13								
	13	EB	0	0	0	0	0		
53rd St	13	SW	0	0	0	-4	0		
	13	NB	0	0	0	0	0		
FDR Drive	13	SB	0	0	0	-3	0		-7
61st St & 5th Ave 2019 (TMC-035)	14								
	14	EB	0	0	0	0	0		
61st St	14	WB	0	1	0	0	0		
	14	NB	0	0	0	0	0		
5th Ave	14	SB	0	0	-29	0	0		-28
65th St & 5th Ave 2019 (TMC-036)	15								
65th St	15	EB	0	0	2	1	0		
	15	WB	0	0	0	0	0		
	15	NB	0	0	0	0	0		
5th Ave	15	SB	0	0	-4	0	0		-1
66th St & 5th Ave 2019 (TMC-037)	16								
	16	EB	0	0	0	0	0		
66th St	16	WB	0	0	2	0	0		
	16	NB	0	0	0	0	0		
5th Ave	16	SB	0	0	-4	-2	0		-4
79th St & 5th Ave 2019 (TMC-038)	17								
79th St	17	EB	0	0	1	1	0		
79th St	17	WB	0	0	-1	0	0		
	17	NB	0	0	0	0	0		
5th Ave	17	SB	0	-1	-4	-2	0		-6
71st St & York Ave 2019 (TMC-039)	18								
	18	EB	0	0	0	0	0		
71st St	18	WB	0	0	0	-1	0		
York Ave	18	NB	0	0	-9	0	0		
York Ave	18	SB	0	0	-9	-1	0		-20

CBD Tolling
UE #1 - Traffic Flowmap
LN No-Action Increment



- Legend:**
- 1 - Intersection (2019 Collected Data)
 - 7 - Intersection (Uncollected Data)
 - 100 - ATR Volume
 - 100 - Approach Volume

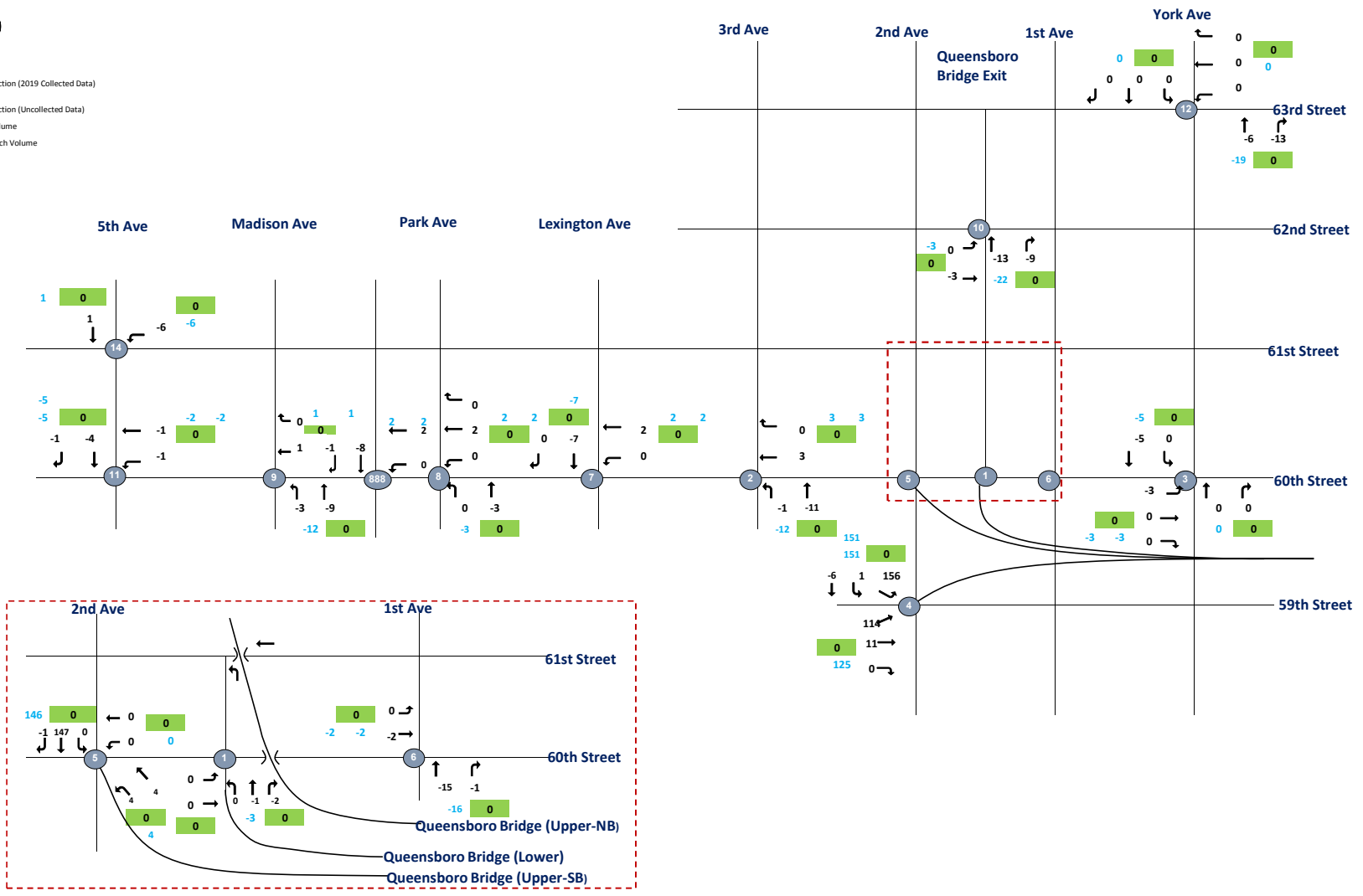

CBD Tolling
UE #2 - Traffic Flowmap
LN No-Action Increment



- Legend:**
- Intersection (2019 Collected Data)
 - Intersection (Uncollected Data)
 - 100 - ATR Volume
 - 100 - Approach Volume

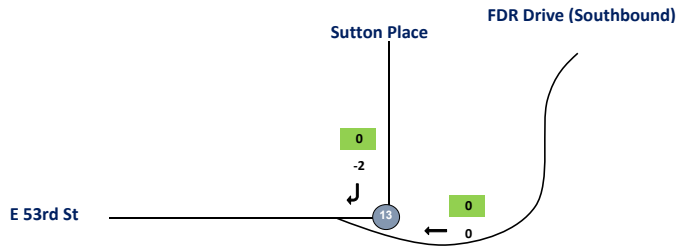

CBD Tolling
UE #3 - Traffic Flowmap
LN No-Action Increment



- Legend:**
- 1 - Intersection (2019 Collected Data)
 - 7 - Intersection (Uncollected Data)
 - 100 - ATR Volume
 - 100 - Approach Volume

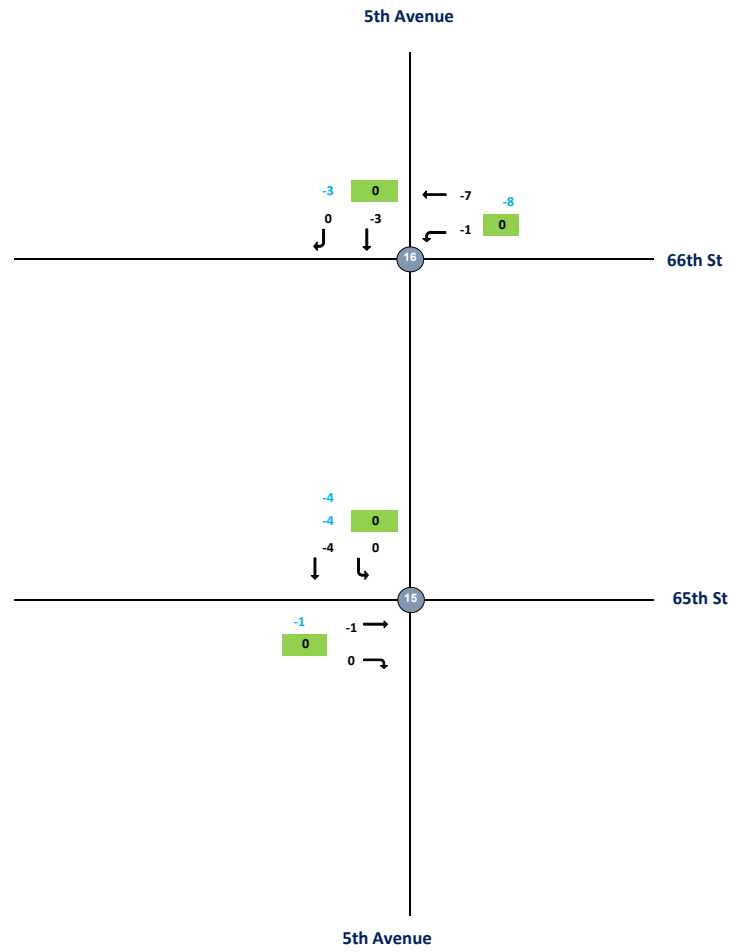

CBD Tolling
UE #3 - Traffic Flowmap
LN No-Action Increment



- Legend:**
- Intersection (2019 Collected Data)
 - Intersection (Uncollected Data)
 - 100 - ATR Volume
 - 100 - Approach Volume

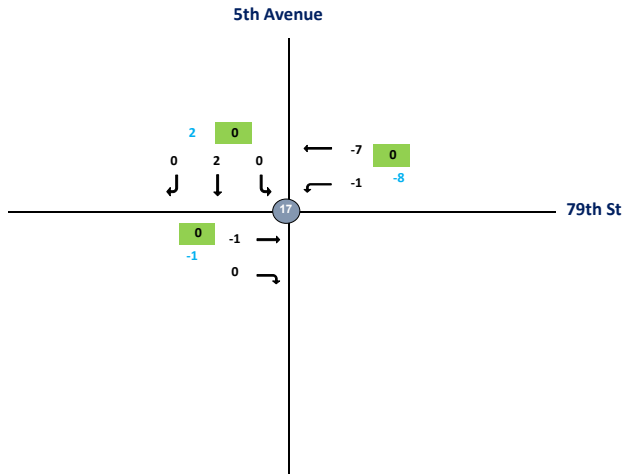

CBD Tolling
UE #4 - Traffic Flowmap
LN No-Action Increment



- Legend:**
- Intersection (2019 Collected Data)
 - 1 - Intersection (Uncollected Data)
 - 100 - ATR Volume
 - 100 - Approach Volume

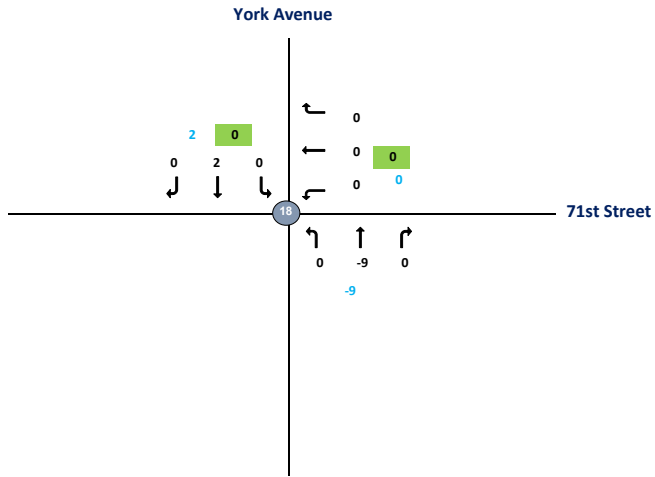

UE

9:00:00 PM

Intersection	Node	Approach	Total Vehicles					
			Inbound/Outbound					
			LN Peak Hour					
			L2	L	T	R	R2	Total
60th Street & Queensboro Bridge Exit								
2019 (TMC-022)	1							
60th Street	1	EB	0	0	0	0	0	
60th Street	1	WB	0	0	0	0	0	
Queensboro Bridge Exit	1	NB	0	0	-1	-2	0	
	1	SB	0	0	0	0	0	-3
60th Street & 3rd Ave								
2019 (TMC-023)	2							
60th Street	2	EB	0	0	0	0	0	
60th Street	2	WB	0	0	3	0	0	
3rd Ave	2	NB	0	-1	-11	0	0	
	2	SB	0	0	0	0	0	-9
60th St & York Ave								
2019 (TMC-024)	3							
60th St	3	EB	0	-3	0	0	0	
60th St	3	WB	0	0	0	0	0	
York Ave	3	NB	0	0	0	0	0	
York Ave	3	SB	0	0	-5	0	0	-8
59th St & 2nd Ave								
2019 (TMC-025)	4							
Queensboro Bridge Exit (SWB)	4							
59th St	4	EB	0	0	114	11	0	
	4	WB	0	0	0	0	0	
	4	NB	0	0	0	0	0	
2nd Ave	4	SB	156	1	-6	0	0	276
60th Street & 2nd Ave								
2019 (TMC-026)	5	WB(bridge)						
Queensboro Bridge Exit (NWB)	5	NW	4	4	0	0	0	
60th St	5	EB	0	0	0	0	0	
60th St	5	WB	0	0	0	0	0	
	5	NB	0	0	0	0	0	
2nd Ave	5	SB	0	0	147	-1	0	146
60th St & 1st Ave								
2019 (TMC-027)	6							
60th Ave	6	EB	0	0	-2	0	0	
	6	WB	0	0	0	0	0	
1st Ave	6	NB	0	0	-15	-1	0	
	6	SB	0	0	0	0	0	-18

60th St & Lexington Ave 2019 (TMC-028)	7								
	7	EB	0	0	0	0	0		
60th St	7	WB	0	0	2	0	0		
	7	NB	0	0	0	0	0		
Lexington Ave	7	SB	0	0	-7	0	0		-5
60th St & Park Ave 2019 (TMC-029)	8								
	8	EB	0	0	0	0	0		
60th St	8	WB	0	0	2	0	0		
Park Ave	8	NB	0	0	-3	0	0		
Park Ave	8	SB	0	0	0	0	0		-1
60th St & Park Ave 2019 (TMC-029)	888								
	888	EB	0	0	0	0	0		
60th St	888	WB	0	0	2	0	0		
Park Ave	888	NB	0	0	0	0	0		
Park Ave	888	SB	0	0	-8	-1	0		-7
60th St & Madison Ave 2019 (TMC-030)	9								
	9	EB	0	0	0	0	0		
60th St	9	WB	0	0	1	0	0		
Madison Ave	9	NB	0	-3	-9	0	0		
	9	SB	0	0	0	0	0		-11
62nd St & Queensboror Bridge Exit 2019 (TMC-031)	10								
62nd St	10	EB	0	0	-3	0	0		
	10	WB	0	0	0	0	0		
Queensboro Bridge Exit	10	NB	0	0	-13	-9	0		
	10	SB	0	0	0	0	0		-25
60th St & 5th Ave 2019 (TMC-032)	11								
	11	EB	0	0	0	0	0		
60th St	11	WB	0	-1	-1	0	0		
	11	NB	0	0	0	0	0		
5th Ave	11	SB	0	0	-4	-1	0		-7

63rd St & York Ave 2019 (TMC-033)	12							
	12	EB	0	0	0	0	0	
63rd St	12	WB	0	0	0	0	0	
York Ave	12	NB	0	0	-6	-13	0	
York Ave	12	SB	0	0	0	0	0	-19
53rd St & FDR Drive 2019 (TMC-034)	13							
	13	EB	0	0	0	0	0	
53rd St	13	SW	0	0	0	0	0	
	13	NB	0	0	0	0	0	
FDR Drive	13	SB	0	0	0	-2	0	-2
61st St & 5th Ave 2019 (TMC-035)	14							
	14	EB	0	0	0	0	0	
61st St	14	WB	0	-6	0	0	0	
	14	NB	0	0	0	0	0	
5th Ave	14	SB	0	0	1	0	0	-5
65th St & 5th Ave 2019 (TMC-036)	15							
65th St	15	EB	0	0	-1	0	0	
	15	WB	0	0	0	0	0	
	15	NB	0	0	0	0	0	
5th Ave	15	SB	0	0	-4	0	0	-5
66th St & 5th Ave 2019 (TMC-037)	16							
	16	EB	0	0	0	0	0	
66th St	16	WB	0	-1	-7	0	0	
	16	NB	0	0	0	0	0	
5th Ave	16	SB	0	0	-3	0	0	-11
79th St & 5th Ave 2019 (TMC-038)	17							
79th St	17	EB	0	0	-1	0	0	
79th St	17	WB	0	-1	-7	0	0	
	17	NB	0	0	0	0	0	
5th Ave	17	SB	0	0	2	0	0	-7
71st St & York Ave 2019 (TMC-039)	18							
	18	EB	0	0	0	0	0	
71st St	18	WB	0	0	0	0	0	
York Ave	18	NB	0	0	-9	0	0	
York Ave	18	SB	0	0	2	0	0	-7

CBD Tolling
UW #1 - Traffic Flowmap
AM No-Action Increment



- Legend:**
- 1 - Intersection (2019 Collected Data)
 - 7 - Intersection (Uncollected Data)
 - 100 - ATR Volume
 - 100 - Approach Volume

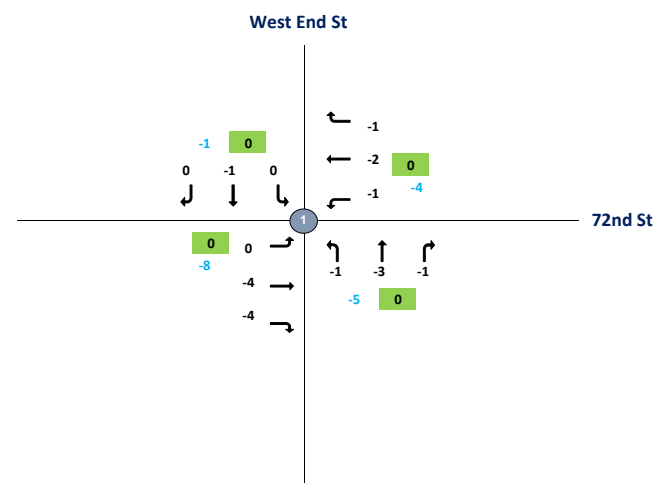

CBD Tolling
UW #2 - Traffic Flowmap
AM No-Action Increment



- Legend:**
- 1 - Intersection (2019 Collected Data)
 - 2 - Intersection (Uncollected Data)
 - 100 - ATR Volume
 - 100 - Approach Volume

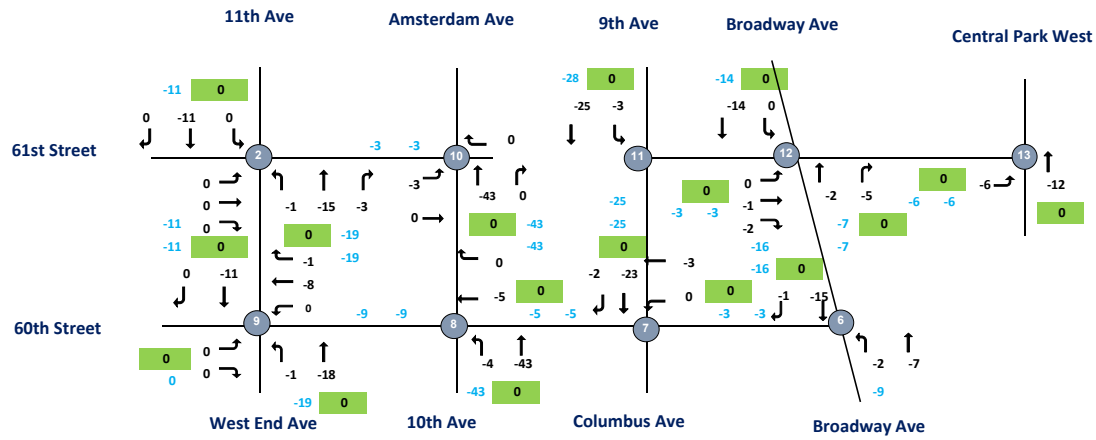

CBD Tolling
UW #4 - Traffic Flowmap
AM No-Action Increment



- Legend:**
- 1 - Intersection (2019 Collected Data)
 - 7 - Intersection (Uncollected Data)
 - 100 - ATR Volume
 - 100 - Approach Volume

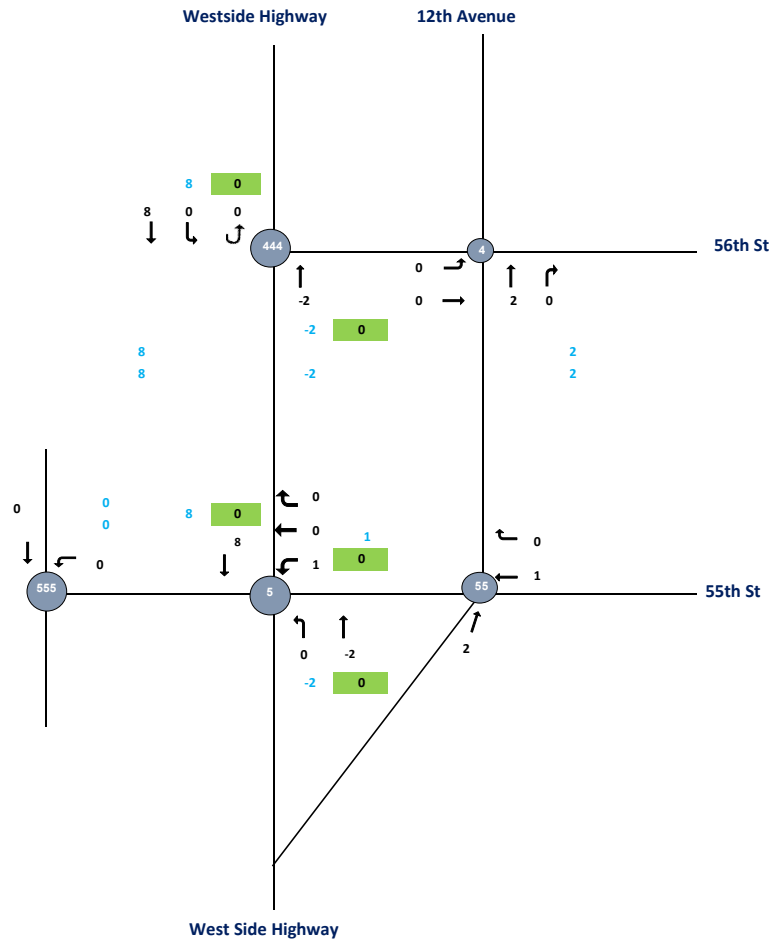

CBD Tolling
UW #5 - Traffic Flowmap
AM No-Action Increment



- Legend:**
- 1 - Intersection (2019 Collected Data)
 - 7 - Intersection (Uncollected Data)
 - 100 - ATR Volume
 - 100 - Approach Volume

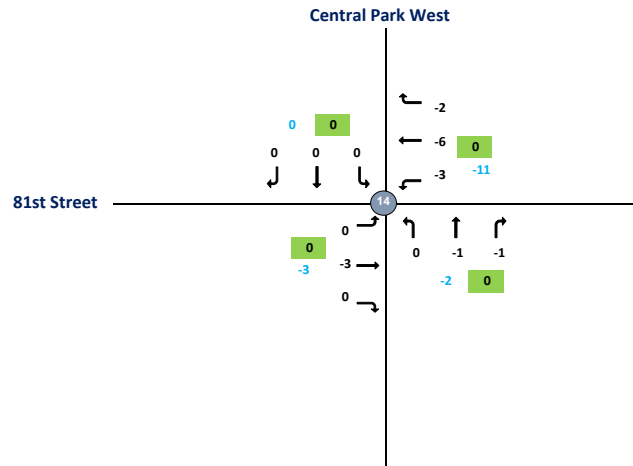

CBD Tolling
UW #6 - Traffic Flowmap
AM No-Action Increment



- Legend:**
- 1 - Intersection (2019 Collected Data)
 - 7 - Intersection (Uncollected Data)
 - 100 - ATR Volume
 - 100 - Approach Volume

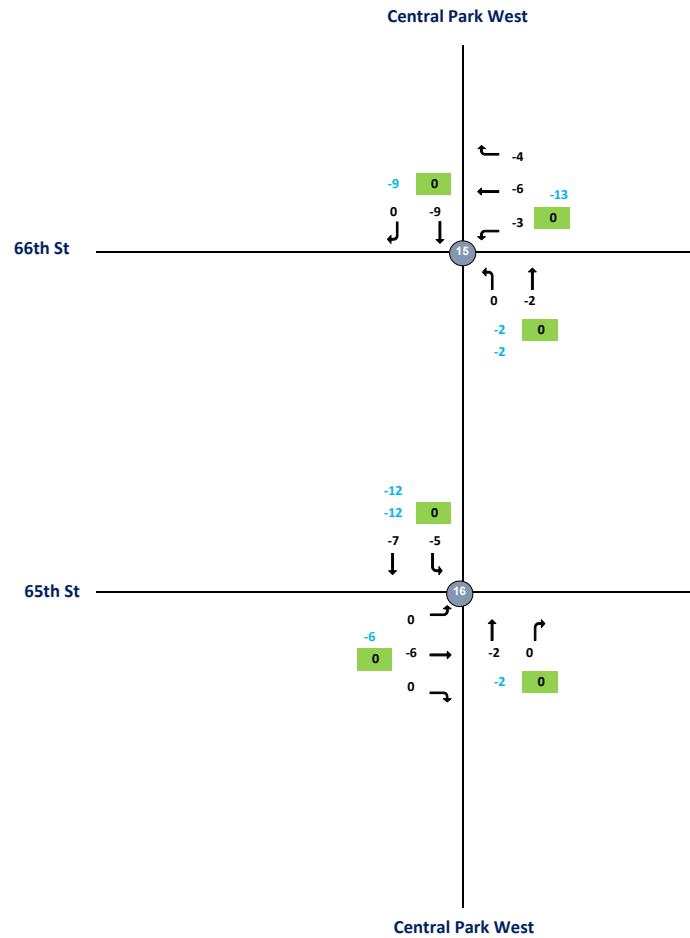

Intersection	Node	Approach	Total Vehicles					
			Inbound/Outbound					
			AM Peak Hour					
			L2	L	T	R	R2	Total
W 72nd St and West End St 2019 (TMC-042)	1							
W 72nd St	1	EB	0	0	-4	-4	0	
W 72nd St	1	WB	0	-1	-2	-1	0	
West End St	1	NB	0	-1	-3	-1	0	
West End St	1	SB	0	0	-1	0	0	-18
W 61st St and West End St 2019 (TMC-043)	2							
W 61st St	2	EB	0	0	0	0	0	
W 61st St	2	WB	0	0	0	0	0	
West End St	2	NB	0	-1	-15	-3	0	
West End St	2	SB	0	0	-11	0	0	-30
W 79th St and Riverside Dr 2019 (TMC-044)	3	NEB						
W 79th St	3	EB	0	0	-8	-5	0	
W 79th St	3	WB	0	0	-5	0	0	
Riverside Dr	3	NB	0	0	0	0	0	
Riverside Dr	3	SB	0	0	0	-1	0	-19
W 79th St and Riverside Dr 2019 (TMC-044)	333							
W 79th St	333	EB	0	0	0	0	0	
W 79th St	333	WB	0	0	0	0	0	
Riverside Dr	333	NB	0	0	0	0	0	
Riverside Dr	333	SB	0	0	0	0	0	0
W 56th St and West Side Hwy 2019 (TMC-045)	4							
-	4	EB	0	0	0	0	0	
W 56th St	4	WB	0	0	0	0	0	
West Side Hwy	4	NB	0	0	2	0	0	
West Side Hwy	4	SB	0	0	0	0	0	2
W 56th St and West Side Hwy 2019 (TMC-045)	444							
-	444	EB	0	0	0	0	0	
W 56th St	444	WB	0	0	0	0	0	
West Side Hwy	444	NB	0	0	-2	0	0	
West Side Hwy	444	SB	0	0	8	0	0	6
W 55th St and West Side Hwy 2019 (TMC-046)	5							
-	5	EB	0	0	0	0	0	
W 55th St	5	WB	0	1	0	0	0	
West Side Hwy	5	NB	0	0	-2	0	0	
West Side Hwy	5	SB	0	0	8	0	0	7

W 55th St and West Side Hwy									
2019 (TMC-046 B B)	55								
-	55	EB	0	0	0	0	0		
W 55th St	55	WB	0	0	1	0	0		
West Side Hwy	55	NB	0	0	2	0	0		
West Side Hwy	55	SB	0	0	0	0	0		3
W 55th St and West Side Hwy									
2019 (TMC-046)	555								
-	555	EB	0	0	0	0	0		
W 55th St	555	WB	0	0	0	0	0		
West Side Hwy	555	NB	0	0	0	0	0		
West Side Hwy	555	SB	0	0	0	0	0		0
W 60th St and Broadway									
2019 (TMC-047)	6								
-	6	EB	0	0	0	0	0		
W 60th St	6	WB	0	0	0	0	0		
Broadway	6	NB	0	-2	-7	0	0		
Broadway	6	SB	0	0	-15	-1	0		-25
W 60th St and Columbus Ave									
2019 (TMC-048)	7								
W 60th St	7	EB	0	0	0	0	0		
W 60th St	7	WB	0	0	-3	0	0		
Columbus Ave	7	NB	0	0	0	0	0		
Columbus Ave	7	SB	0	0	-23	-2	0		-28
W 60th St and 10th Ave									
2019 (TMC-049)	8								
W 60th St	8	EB	0	0	0	0	0		
W 60th St	8	WB	0	0	-5	0	0		
10th Ave	8	NB	0	-4	-43	0	0		
10th Ave	8	SB	0	0	0	0	0		-52
W 60th St and 11th Ave									
2019 (TMC-050)	9								
W 60th St	9	EB	0	0	0	0	0		
W 60th St	9	WB	0	0	-8	-1	0		
11th Ave	9	NB	0	-1	-18	0	0		
11th Ave	9	SB	0	0	-11	0	0		-39
W 61st St and 10th Ave									
2019 (TMC-051)	10								
W 61st St	10	EB	0	-3	0	0	0		
W 61st St	10	WB	0	0	0	0	0		
10th Ave	10	NB	0	0	-43	0	0		
10th Ave	10	SB	0	0	0	0	0		-46

W 61st St and Columbus Ave									
2019 (TMC-052)	11								
-	11	EB	0	0	0	0	0		
W 61st St	11	WB	0	0	0	0	0		
Columbus Ave	11	NB	0	0	0	0	0		
Columbus Ave	11	SB	0	-3	-25	0	0		-28
W 61st St and Broadway									
2019 (TMC-053)	12								
W 61st St	12	EB	0	0	-1	-2	0		
W 61st St	12	WB	0	0	0	0	0		
Broadway	12	NB	0	0	-2	-5	0		
Broadway	12	SB	0	0	-14	0	0		-24
Central Park and W 61st St									
2019 (TMC-054)	13								
W 61st St	13	EB	0	-6	0	0	0		
-	13	WB	0	0	0	0	0		
Central Park	13	NB	0	0	-12	0	0		
Central Park	13	SB	0	0	0	0	0		-18
Central Park and W 81st St									
2019 (TMC-055)	14								
W 81st St	14	EB	0	0	-3	0	0		
W 79th St Transverse	14	WB	0	-3	-6	-2	0		
Central Park	14	NB	0	0	-1	-1	0		
Central Park	14	SB	0	0	0	0	0		-16
Central Park West and W 66th St									
2019 (TMC-056)	15								
W 66th St	15	EB	0	0	0	0	0		
W 66th St	15	WB	0	-3	-6	-4	0		
Central Park West	15	NB	0	0	-2	0	0		
Central Park West	15	SB	0	0	-9	0	0		-24
Central Park West and W 65th St									
2019 (TMC-057)	16								
W 65th St	16	EB	0	0	-6	0	0		
W 65th St	16	WB	0	0	0	0	0		
Central Park West	16	NB	0	0	-2	0	0		
Central Park West	16	SB	0	-5	-7	0	0		-20

CBD Tolling
UW #1 - Traffic Flowmap
MD No-Action Increment



- Legend:**
- 1 - Intersection (2019 Collected Data)
 - 7 - Intersection (Uncollected Data)
 - 100 - ATR Volume
 - 100 - Approach Volume

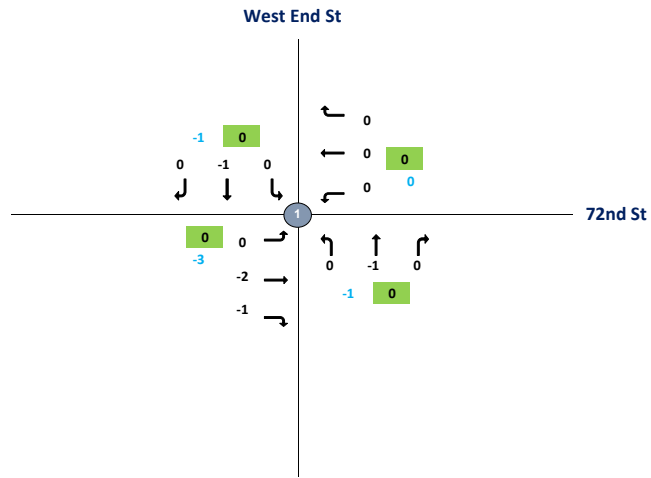

CBD Tolling
UW #2 - Traffic Flowmap
MD No-Action Increment



- Legend:**
- 1 - Intersection (2019 Collected Data)
 - 2 - Intersection (Uncollected Data)
 - 3 - Intersection (Uncollected Data)
 - 100 - ATR Volume
 - 100 - Approach Volume

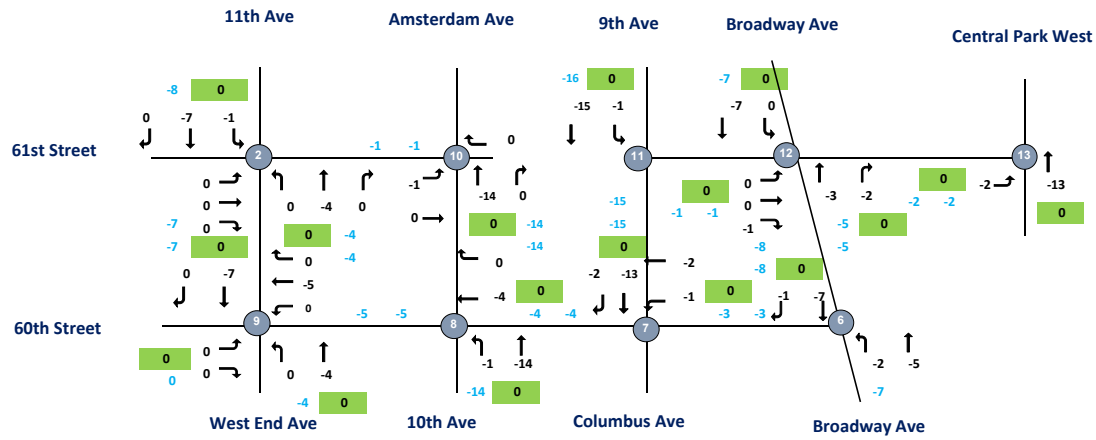

CBD Tolling
UW #3 - Traffic Flowmap
MD No-Action Increment



- Legend:**
- Intersection (2019 Collected Data)
 - Intersection (Uncollected Data)
 - ATR Volume
 - Approach Volume

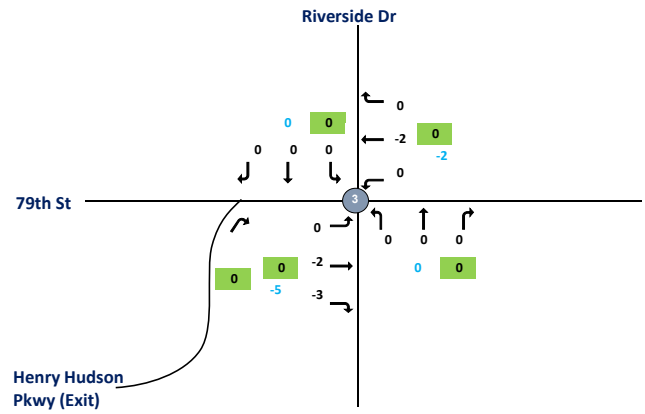

CBD Tolling
UW #4 - Traffic Flowmap
MD No-Action Increment



- Legend:**
- 1 - Intersection (2019 Collected Data)
 - 7 - Intersection (Uncollected Data)
 - 100 - ATR Volume
 - 100 - Approach Volume

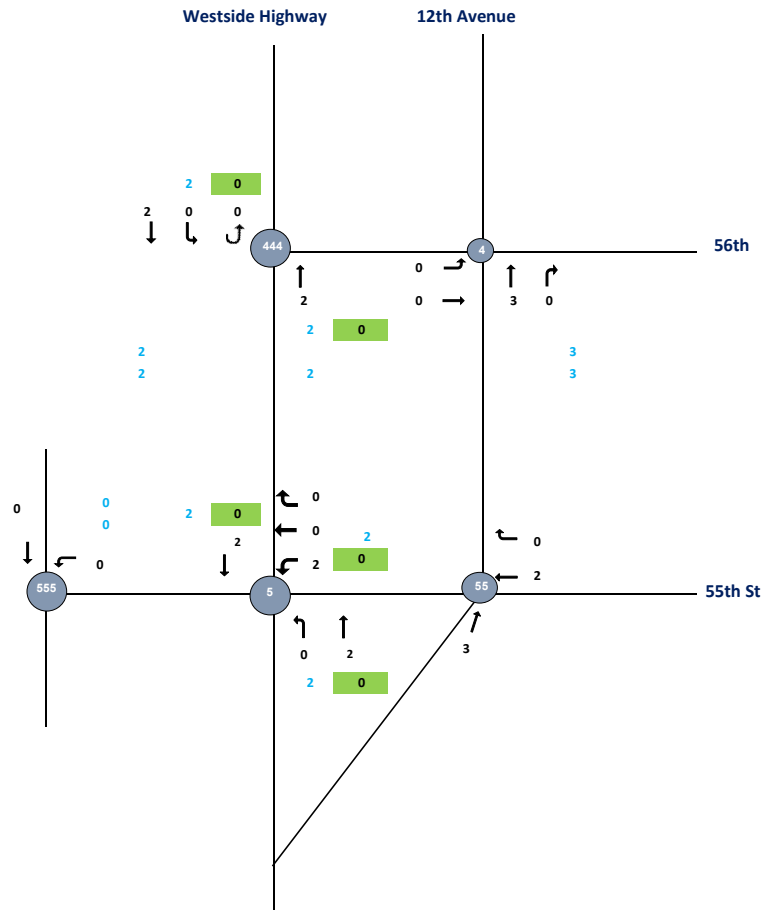

CBD Tolling
UW #5 - Traffic Flowmap
MD No-Action Increment



- Legend:**
- 1 - Intersection (2019 Collected Data)
 - 7 - Intersection (Uncollected Data)
 - 100 - ATR Volume
 - 100 - Approach Volume

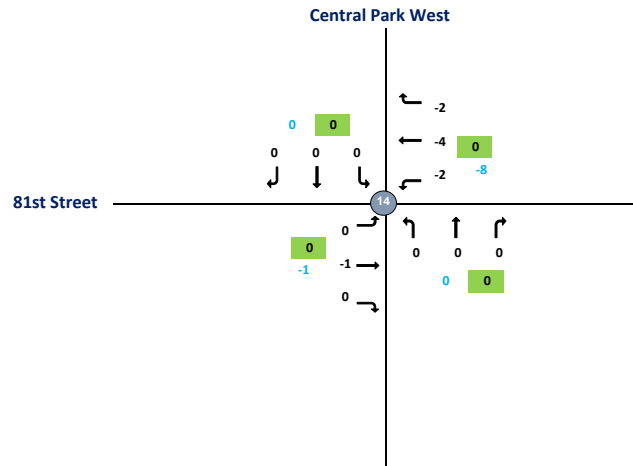

CBD Tolling
UW #6 - Traffic Flowmap
MD No-Action Increment



- Legend:**
- 1 - Intersection (2019 Collected Data)
 - 7 - Intersection (Uncollected Data)
 - 100 - ATR Volume
 - 100 - Approach Volume

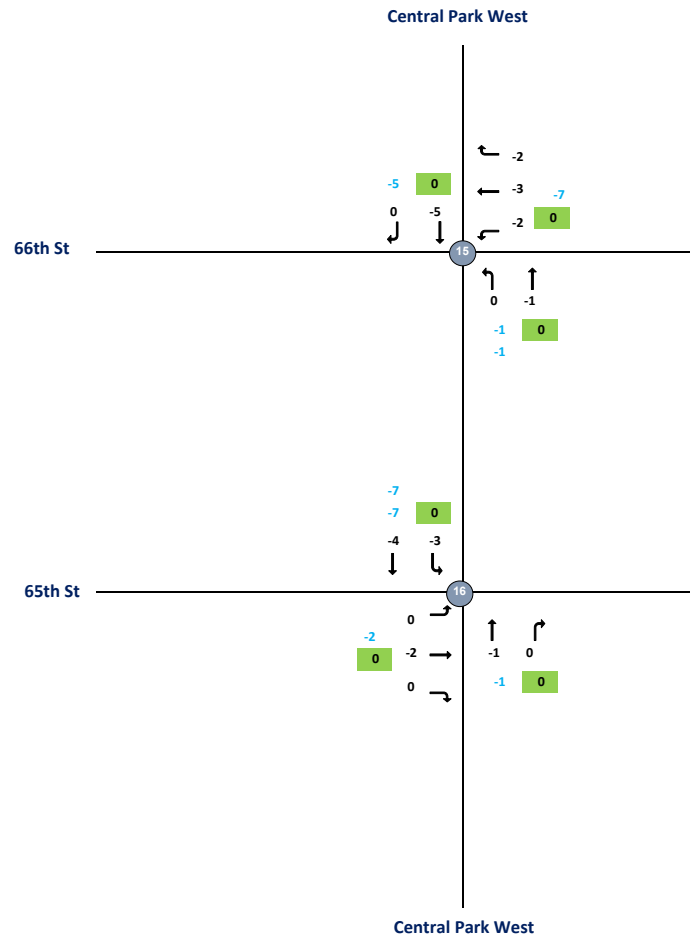

Intersection	Node	Approach	Total Vehicles					
			Inbound/Outbound					
			MD Peak Hour					
			L2	L	T	R	R2	Total
W 72nd St and West End St 2019 (TMC-042)	1							
W 72nd St	1	EB	0	0	-2	-1	0	
W 72nd St	1	WB	0	0	0	0	0	
West End St	1	NB	0	0	-1	0	0	
West End St	1	SB	0	0	-1	0	0	-5
W 61st St and West End St 2019 (TMC-043)	2							
W 61st St	2	EB	0	0	0	0	0	
W 61st St	2	WB	0	0	0	0	0	
West End St	2	NB	0	0	-4	0	0	
West End St	2	SB	0	-1	-7	0	0	-12
W 79th St and Riverside Dr 2019 (TMC-044)	3	NEB						
W 79th St	3	EB	0	0	-2	-3	0	
W 79th St	3	WB	0	0	-2	0	0	
Riverside Dr	3	NB	0	0	0	0	0	
Riverside Dr	3	SB	0	0	0	0	0	-7
W 79th St and Riverside Dr 2019 (TMC-044)	333							
W 79th St	333	EB	0	0	0	0	0	
W 79th St	333	WB	0	0	0	0	0	
Riverside Dr	333	NB	0	0	0	0	0	
Riverside Dr	333	SB	0	0	0	0	0	0
W 56th St and West Side Hwy 2019 (TMC-045)	4							
-	4	EB	0	0	0	0	0	
W 56th St	4	WB	0	0	0	0	0	
West Side Hwy	4	NB	0	0	3	0	0	
West Side Hwy	4	SB	0	0	0	0	0	3
W 56th St and West Side Hwy 2019 (TMC-045)	444							
-	444	EB	0	0	0	0	0	
W 56th St	444	WB	0	0	0	0	0	
West Side Hwy	444	NB	0	0	2	0	0	
West Side Hwy	444	SB	0	0	2	0	0	4
W 55th St and West Side Hwy 2019 (TMC-046)	5							
-	5	EB	0	0	0	0	0	
W 55th St	5	WB	0	2	0	0	0	
West Side Hwy	5	NB	0	0	2	0	0	
West Side Hwy	5	SB	0	0	2	0	0	6

W 55th St and West Side Hwy									
2019 (TMC-046 B B)		55							
-	55	EB	0	0	0	0	0		
W 55th St	55	WB	0	0	2	0	0		
West Side Hwy	55	NB	0	0	3	0	0		
West Side Hwy	55	SB	0	0	0	0	0		5
W 55th St and West Side Hwy									
2019 (TMC-046)		555							
-	555	EB	0	0	0	0	0		
W 55th St	555	WB	0	0	0	0	0		
West Side Hwy	555	NB	0	0	0	0	0		
West Side Hwy	555	SB	0	0	0	0	0		0
W 60th St and Broadway									
2019 (TMC-047)		6							
-	6	EB	0	0	0	0	0		
W 60th St	6	WB	0	0	0	0	0		
Broadway	6	NB	0	-2	-5	0	0		
Broadway	6	SB	0	0	-7	-1	0		-15
W 60th St and Columbus Ave									
2019 (TMC-048)		7							
W 60th St	7	EB	0	0	0	0	0		
W 60th St	7	WB	0	-1	-2	0	0		
Columbus Ave	7	NB	0	0	0	0	0		
Columbus Ave	7	SB	0	0	-13	-2	0		-18
W 60th St and 10th Ave									
2019 (TMC-049)		8							
W 60th St	8	EB	0	0	0	0	0		
W 60th St	8	WB	0	0	-4	0	0		
10th Ave	8	NB	0	-1	-14	0	0		
10th Ave	8	SB	0	0	0	0	0		-19
W 60th St and 11th Ave									
2019 (TMC-050)		9							
W 60th St	9	EB	0	0	0	0	0		
W 60th St	9	WB	0	0	-5	0	0		
11th Ave	9	NB	0	0	-4	0	0		
11th Ave	9	SB	0	0	-7	0	0		-16
W 61st St and 10th Ave									
2019 (TMC-051)		10							
W 61st St	10	EB	0	-1	0	0	0		
W 61st St	10	WB	0	0	0	0	0		
10th Ave	10	NB	0	0	-14	0	0		
10th Ave	10	SB	0	0	0	0	0		-15

W 61st St and Columbus Ave									
2019 (TMC-052)	11								
-	11	EB	0	0	0	0	0		
W 61st St	11	WB	0	0	0	0	0		
Columbus Ave	11	NB	0	0	0	0	0		
Columbus Ave	11	SB	0	-1	-15	0	0		-16
W 61st St and Broadway									
2019 (TMC-053)	12								
W 61st St	12	EB	0	0	0	-1	0		
W 61st St	12	WB	0	0	0	0	0		
Broadway	12	NB	0	0	-3	-2	0		
Broadway	12	SB	0	0	-7	0	0		-13
Central Park and W 61st St									
2019 (TMC-054)	13								
W 61st St	13	EB	0	-2	0	0	0		
-	13	WB	0	0	0	0	0		
Central Park	13	NB	0	0	-13	0	0		
Central Park	13	SB	0	0	0	0	0		-15
Central Park and W 81st St									
2019 (TMC-055)	14								
W 81st St	14	EB	0	0	-1	0	0		
W 79th St Transverse	14	WB	0	-2	-4	-2	0		
Central Park	14	NB	0	0	0	0	0		
Central Park	14	SB	0	0	0	0	0		-9
Central Park West and W 66th St									
2019 (TMC-056)	15								
W 66th St	15	EB	0	0	0	0	0		
W 66th St	15	WB	0	-2	-3	-2	0		
Central Park West	15	NB	0	0	-1	0	0		
Central Park West	15	SB	0	0	-5	0	0		-13
Central Park West and W 65th St									
2019 (TMC-057)	16								
W 65th St	16	EB	0	0	-2	0	0		
W 65th St	16	WB	0	0	0	0	0		
Central Park West	16	NB	0	0	-1	0	0		
Central Park West	16	SB	0	-3	-4	0	0		-10

CBD Tolling
UW #1 - Traffic Flowmap
PM No-Action Increment



- Legend:**
- 1 - Intersection (2019 Collected Data)
 - 7 - Intersection (Uncollected Data)
 - 100 - ATR Volume
 - 100 - Approach Volume

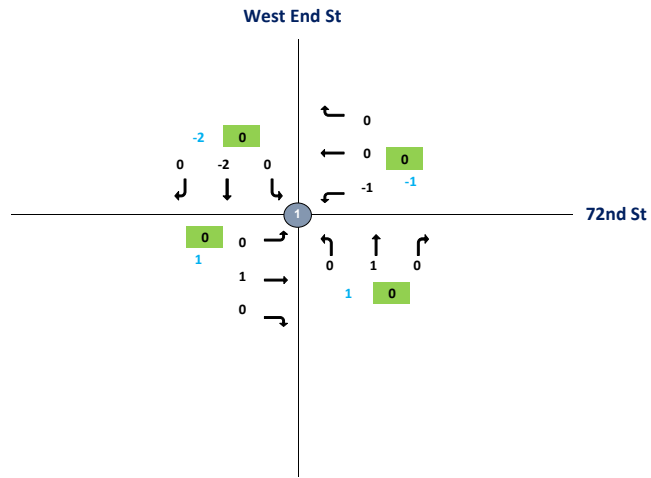

CBD Tolling
UW #2 - Traffic Flowmap
PM No-Action Increment



- Legend:**
- 1 - Intersection (2019 Collected Data)
 - 2 - Intersection (Uncollected Data)
 - 100 - ATR Volume
 - 100 - Approach Volume

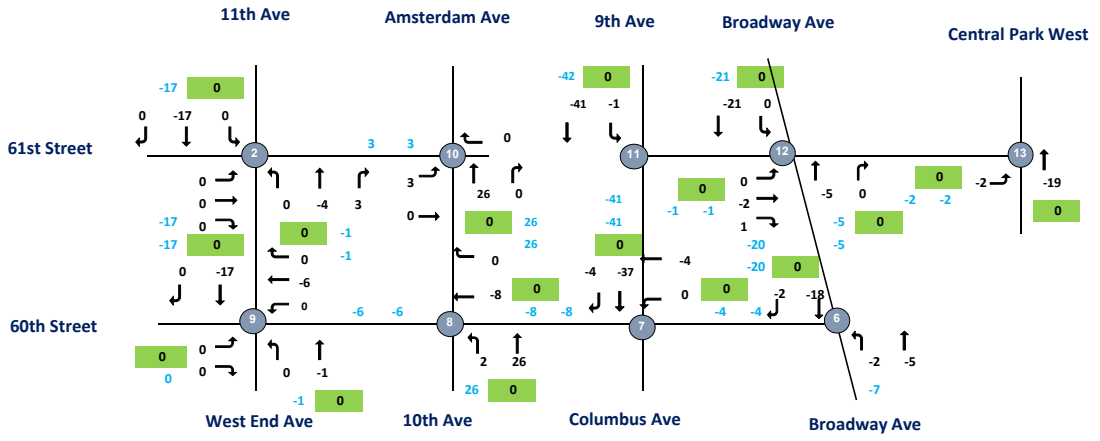

CBD Tolling
UW #3 - Traffic Flowmap
PM No-Action Increment



- Legend:**
- Intersection (2019 Collected Data)
 - Intersection (Uncollected Data)
 - ATR Volume
 - Approach Volume

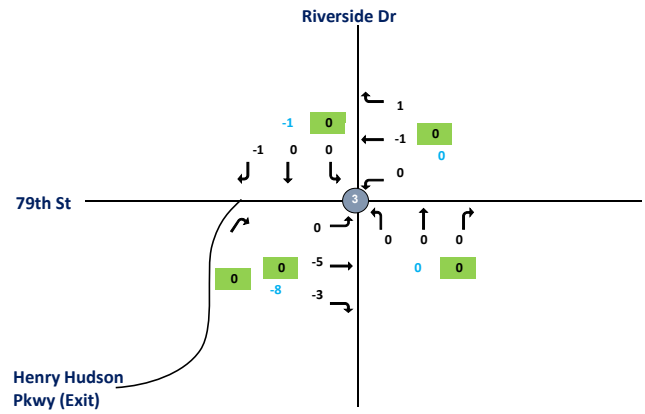

CBD Tolling
UW #4 - Traffic Flowmap
PM No-Action Increment



- Legend:**
- 1 - Intersection (2019 Collected Data)
 - 7 - Intersection (Uncollected Data)
 - 100 - ATR Volume
 - 100 - Approach Volume

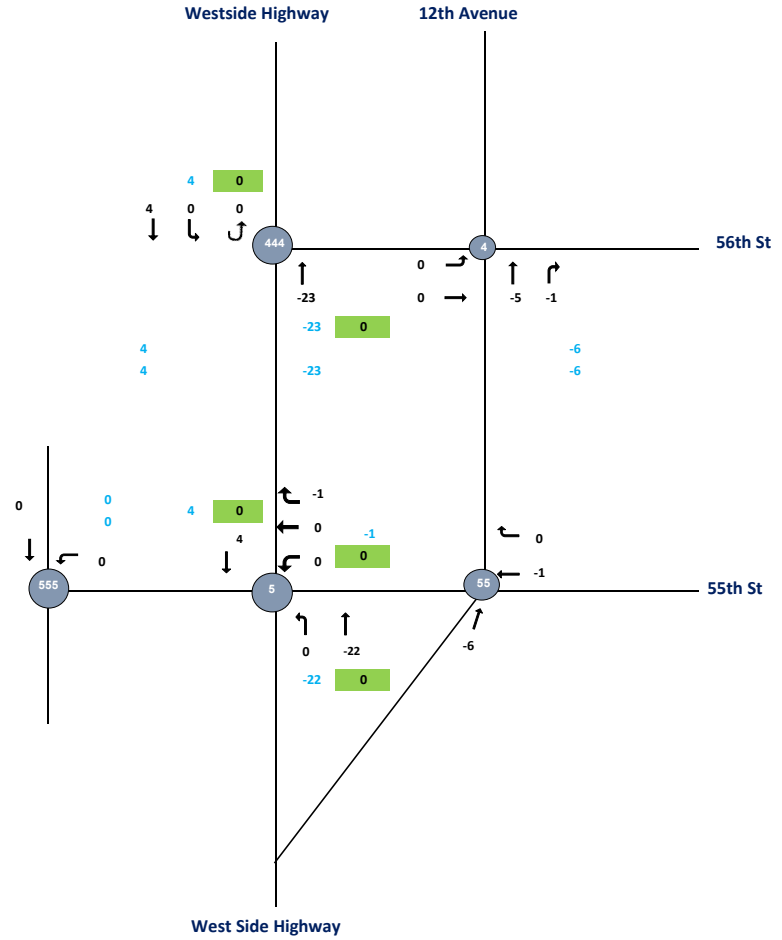

CBD Tolling
UW #5 - Traffic Flowmap
PM No-Action Increment



- Legend:**
- 1 - Intersection (2019 Collected Data)
 - 7 - Intersection (Uncollected Data)
 - 100 - ATR Volume
 - 100 - Approach Volume

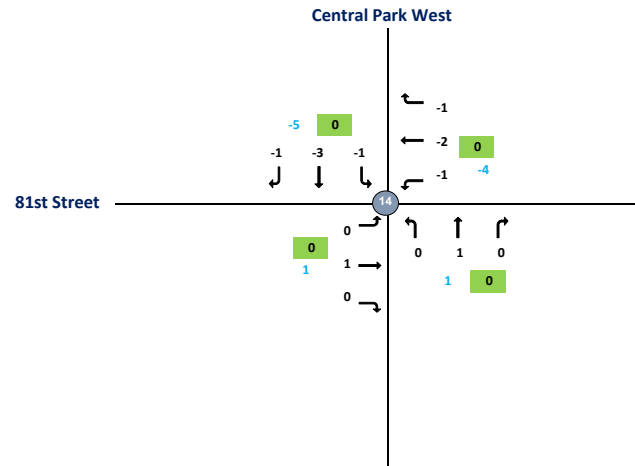

CBD Tolling
UW #6 - Traffic Flowmap
PM No-Action Increment



- Legend:**
- 1 - Intersection (2019 Collected Data)
 - 7 - Intersection (Uncollected Data)
 - 100 - ATR Volume
 - 100 - Approach Volume

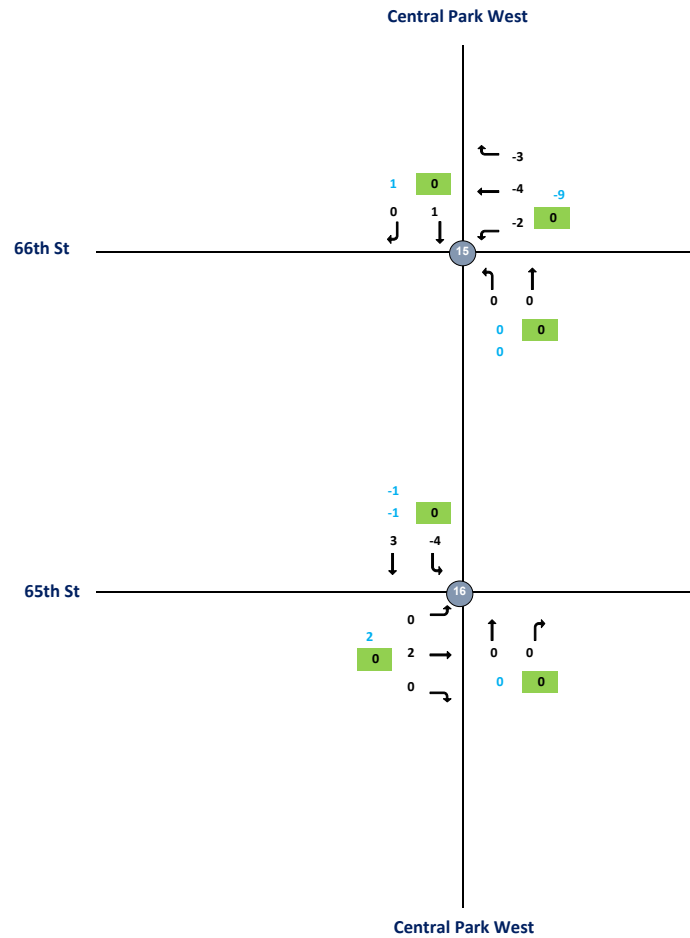

Intersection	Node	Approach	Total Vehicles					
			Inbound/Outbound					
			PM Peak Hour					
			L2	L	T	R	R2	Total
W 72nd St and West End St 2019 (TMC-042)	1							
W 72nd St	1	EB	0	0	1	0	0	
W 72nd St	1	WB	0	-1	0	0	0	
West End St	1	NB	0	0	1	0	0	
West End St	1	SB	0	0	-2	0	0	-1
W 61st St and West End St 2019 (TMC-043)	2							
W 61st St	2	EB	0	0	0	0	0	
W 61st St	2	WB	0	0	0	0	0	
West End St	2	NB	0	0	-4	3	0	
West End St	2	SB	0	0	-17	0	0	-18
W 79th St and Riverside Dr 2019 (TMC-044)	3	NEB						
W 79th St	3	EB	0	0	-5	-3	0	
W 79th St	3	WB	0	0	-1	1	0	
Riverside Dr	3	NB	0	0	0	0	0	
Riverside Dr	3	SB	0	0	0	-1	0	-9
W 79th St and Riverside Dr 2019 (TMC-044)	333							
W 79th St	333	EB	0	0	0	0	0	
W 79th St	333	WB	0	0	0	0	0	
Riverside Dr	333	NB	0	0	0	0	0	
Riverside Dr	333	SB	0	0	0	0	0	0
W 56th St and West Side Hwy 2019 (TMC-045)	4							
-	4	EB	0	0	0	0	0	
W 56th St	4	WB	0	0	0	0	0	
West Side Hwy	4	NB	0	0	-5	-1	0	
West Side Hwy	4	SB	0	0	0	0	0	-6
W 56th St and West Side Hwy 2019 (TMC-045)	444							
-	444	EB	0	0	0	0	0	
W 56th St	444	WB	0	0	0	0	0	
West Side Hwy	444	NB	0	0	-23	0	0	
West Side Hwy	444	SB	0	0	4	0	0	-19
W 55th St and West Side Hwy 2019 (TMC-046)	5							
-	5	EB	0	0	0	0	0	
W 55th St	5	WB	0	0	0	-1	0	
West Side Hwy	5	NB	0	0	-22	0	0	
West Side Hwy	5	SB	0	0	4	0	0	-19

W 55th St and West Side Hwy									
2019 (TMC-046 B B)		55							
-		55	EB	0	0	0	0	0	
W 55th St		55	WB	0	0	-1	0	0	
West Side Hwy		55	NB	0	0	-6	0	0	
West Side Hwy		55	SB	0	0	0	0	0	-7
W 55th St and West Side Hwy									
2019 (TMC-046)		555							
-		555	EB	0	0	0	0	0	
W 55th St		555	WB	0	0	0	0	0	
West Side Hwy		555	NB	0	0	0	0	0	
West Side Hwy		555	SB	0	0	0	0	0	0
W 60th St and Broadway									
2019 (TMC-047)		6							
-		6	EB	0	0	0	0	0	
W 60th St		6	WB	0	0	0	0	0	
Broadway		6	NB	0	-2	-5	0	0	
Broadway		6	SB	0	0	-18	-2	0	-27
W 60th St and Columbus Ave									
2019 (TMC-048)		7							
W 60th St		7	EB	0	0	0	0	0	
W 60th St		7	WB	0	0	-4	0	0	
Columbus Ave		7	NB	0	0	0	0	0	
Columbus Ave		7	SB	0	0	-37	-4	0	-45
W 60th St and 10th Ave									
2019 (TMC-049)		8							
W 60th St		8	EB	0	0	0	0	0	
W 60th St		8	WB	0	0	-8	0	0	
10th Ave		8	NB	0	2	26	0	0	
10th Ave		8	SB	0	0	0	0	0	20
W 60th St and 11th Ave									
2019 (TMC-050)		9							
W 60th St		9	EB	0	0	0	0	0	
W 60th St		9	WB	0	0	-6	0	0	
11th Ave		9	NB	0	0	-1	0	0	
11th Ave		9	SB	0	0	-17	0	0	-24
W 61st St and 10th Ave									
2019 (TMC-051)		10							
W 61st St		10	EB	0	3	0	0	0	
W 61st St		10	WB	0	0	0	0	0	
10th Ave		10	NB	0	0	26	0	0	
10th Ave		10	SB	0	0	0	0	0	29

W 61st St and Columbus Ave									
2019 (TMC-052)	11								
-	11	EB	0	0	0	0	0		
W 61st St	11	WB	0	0	0	0	0		
Columbus Ave	11	NB	0	0	0	0	0		
Columbus Ave	11	SB	0	-1	-41	0	0		-42
W 61st St and Broadway									
2019 (TMC-053)	12								
W 61st St	12	EB	0	0	-2	1	0		
W 61st St	12	WB	0	0	0	0	0		
Broadway	12	NB	0	0	-5	0	0		
Broadway	12	SB	0	0	-21	0	0		-27
Central Park and W 61st St									
2019 (TMC-054)	13								
W 61st St	13	EB	0	-2	0	0	0		
-	13	WB	0	0	0	0	0		
Central Park	13	NB	0	0	-19	0	0		
Central Park	13	SB	0	0	0	0	0		-21
Central Park and W 81st St									
2019 (TMC-055)	14								
W 81st St	14	EB	0	0	1	0	0		
W 79th St Transverse	14	WB	0	-1	-2	-1	0		
Central Park	14	NB	0	0	1	0	0		
Central Park	14	SB	0	-1	-3	-1	0		-7
Central Park West and W 66th St									
2019 (TMC-056)	15								
W 66th St	15	EB	0	0	0	0	0		
W 66th St	15	WB	0	-2	-4	-3	0		
Central Park West	15	NB	0	0	0	0	0		
Central Park West	15	SB	0	0	1	0	0		-8
Central Park West and W 65th St									
2019 (TMC-057)	16								
W 65th St	16	EB	0	0	2	0	0		
W 65th St	16	WB	0	0	0	0	0		
Central Park West	16	NB	0	0	0	0	0		
Central Park West	16	SB	0	-4	3	0	0		1

CBD Tolling
UW #1 - Traffic Flowmap
LN No-Action Increment



- Legend:**
- 1 - Intersection (2019 Collected Data)
 - 7 - Intersection (Uncollected Data)
 - 100 - ATR Volume
 - 100 - Approach Volume

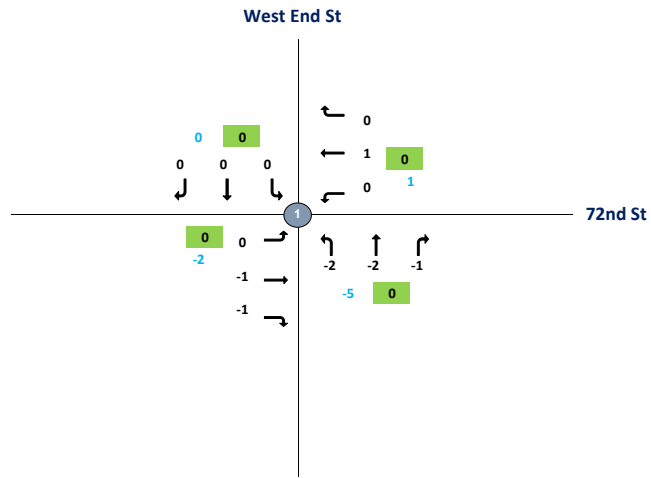

CBD Tolling
UW #2 - Traffic Flowmap
LN No-Action Increment



- Legend:**
- 1 - Intersection (2019 Collected Data)
 - 7 - Intersection (Uncollected Data)
 - 100 - ATR Volume
 - 100 - Approach Volume

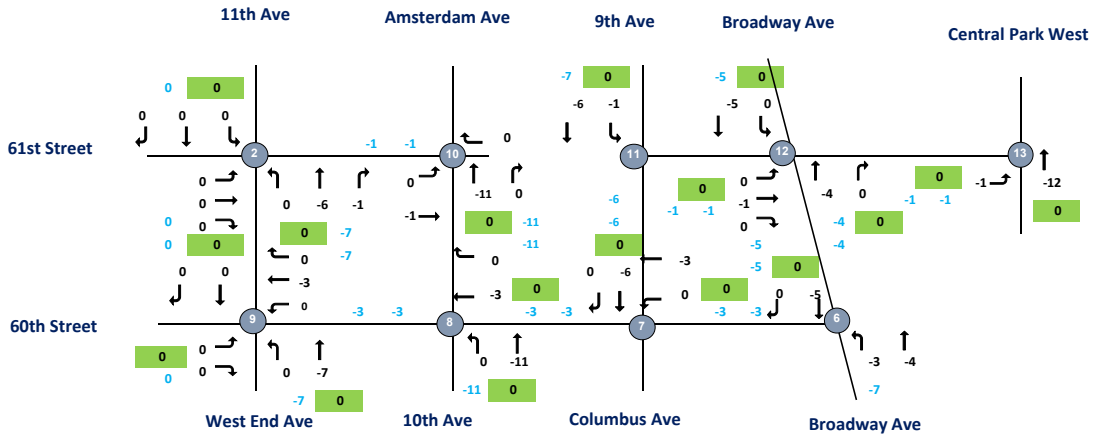

CBD Tolling
UW #3 - Traffic Flowmap
LN No-Action Increment



- Legend:**
- Intersection (2019 Collected Data)
 - Intersection (Uncollected Data)
 - ATR Volume
 - Approach Volume

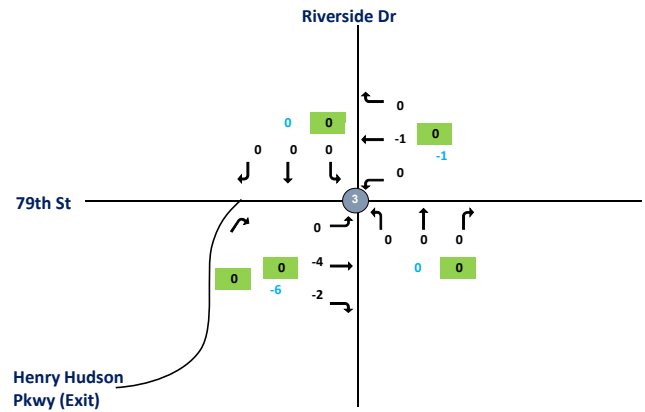

CBD Tolling
UW #4 - Traffic Flowmap
LN No-Action Increment



- Legend:**
- 1 - Intersection (2019 Collected Data)
 - 7 - Intersection (Uncollected Data)
 - 100 - ATR Volume
 - 100 - Approach Volume

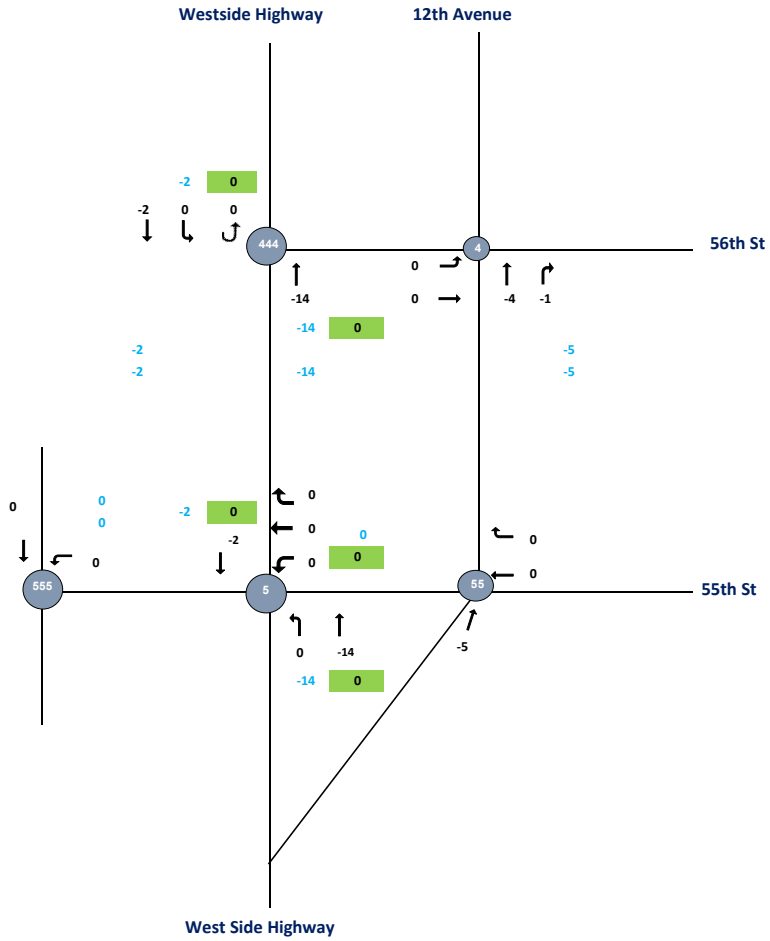

CBD Tolling
UW #5 - Traffic Flowmap
LN No-Action Increment



- Legend:**
- 1 - Intersection (2019 Collected Data)
 - 7 - Intersection (Uncollected Data)
 - 100 - ATR Volume
 - 100 - Approach Volume

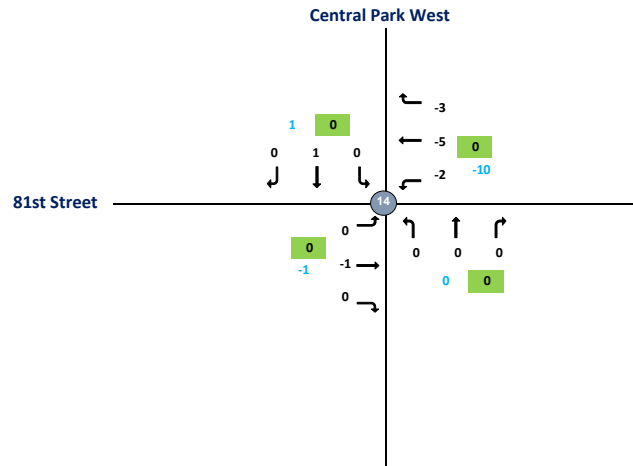

CBD Tolling
UW #6 - Traffic Flowmap
LN No-Action Increment



- Legend:**
- 1 - Intersection (2019 Collected Data)
 - 7 - Intersection (Uncollected Data)
 - 100 - ATR Volume
 - 100 - Approach Volume

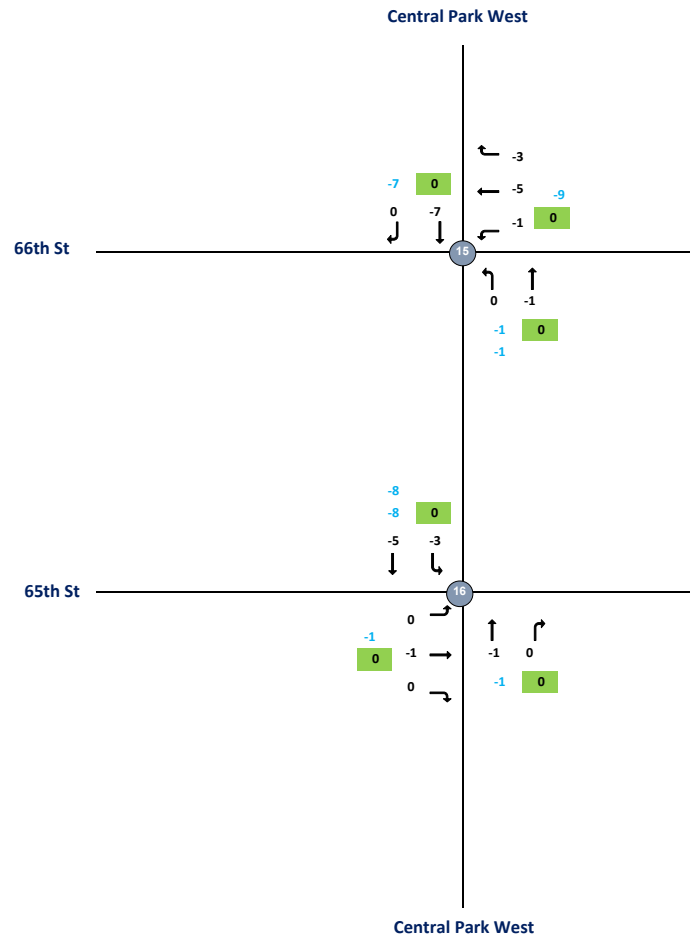

Intersection	Node	Approach	Total Vehicles					
			Inbound/Outbound					
			LN Peak Hour					
			L2	L	T	R	R2	Total
W 72nd St and West End St 2019 (TMC-042)	1							
W 72nd St	1	EB	0	0	-1	-1	0	
W 72nd St	1	WB	0	0	1	0	0	
West End St	1	NB	0	-2	-2	-1	0	
West End St	1	SB	0	0	0	0	0	-6
W 61st St and West End St 2019 (TMC-043)	2							
W 61st St	2	EB	0	0	0	0	0	
W 61st St	2	WB	0	0	0	0	0	
West End St	2	NB	0	0	-6	-1	0	
West End St	2	SB	0	0	0	0	0	-7
W 79th St and Riverside Dr 2019 (TMC-044)	3	NEB						
W 79th St	3	EB	0	0	-4	-2	0	
W 79th St	3	WB	0	0	-1	0	0	
Riverside Dr	3	NB	0	0	0	0	0	
Riverside Dr	3	SB	0	0	0	0	0	-7
W 79th St and Riverside Dr 2019 (TMC-044)	333							
W 79th St	333	EB	0	0	0	0	0	
W 79th St	333	WB	0	0	0	0	0	
Riverside Dr	333	NB	0	0	0	0	0	
Riverside Dr	333	SB	0	0	0	0	0	0
W 56th St and West Side Hwy 2019 (TMC-045)	4							
-	4	EB	0	0	0	0	0	
W 56th St	4	WB	0	0	0	0	0	
West Side Hwy	4	NB	0	0	-4	-1	0	
West Side Hwy	4	SB	0	0	0	0	0	-5
W 56th St and West Side Hwy 2019 (TMC-045)	444							
-	444	EB	0	0	0	0	0	
W 56th St	444	WB	0	0	0	0	0	
West Side Hwy	444	NB	0	0	-14	0	0	
West Side Hwy	444	SB	0	0	-2	0	0	-16
W 55th St and West Side Hwy 2019 (TMC-046)	5							
-	5	EB	0	0	0	0	0	
W 55th St	5	WB	0	0	0	0	0	
West Side Hwy	5	NB	0	0	-14	0	0	
West Side Hwy	5	SB	0	0	-2	0	0	-16

W 55th St and West Side Hwy									
2019 (TMC-046 B B)		55							
-		55	EB	0	0	0	0	0	
W 55th St		55	WB	0	0	0	0	0	
West Side Hwy		55	NB	0	0	-5	0	0	
West Side Hwy		55	SB	0	0	0	0	0	-5
W 55th St and West Side Hwy									
2019 (TMC-046)		555							
-		555	EB	0	0	0	0	0	
W 55th St		555	WB	0	0	0	0	0	
West Side Hwy		555	NB	0	0	0	0	0	
West Side Hwy		555	SB	0	0	0	0	0	0
W 60th St and Broadway									
2019 (TMC-047)		6							
-		6	EB	0	0	0	0	0	
W 60th St		6	WB	0	0	0	0	0	
Broadway		6	NB	0	-3	-4	0	0	
Broadway		6	SB	0	0	-5	0	0	-12
W 60th St and Columbus Ave									
2019 (TMC-048)		7							
W 60th St		7	EB	0	0	0	0	0	
W 60th St		7	WB	0	0	-3	0	0	
Columbus Ave		7	NB	0	0	0	0	0	
Columbus Ave		7	SB	0	0	-6	0	0	-9
W 60th St and 10th Ave									
2019 (TMC-049)		8							
W 60th St		8	EB	0	0	0	0	0	
W 60th St		8	WB	0	0	-3	0	0	
10th Ave		8	NB	0	0	-11	0	0	
10th Ave		8	SB	0	0	0	0	0	-14
W 60th St and 11th Ave									
2019 (TMC-050)		9							
W 60th St		9	EB	0	0	0	0	0	
W 60th St		9	WB	0	0	-3	0	0	
11th Ave		9	NB	0	0	-7	0	0	
11th Ave		9	SB	0	0	0	0	0	-10
W 61st St and 10th Ave									
2019 (TMC-051)		10							
W 61st St		10	EB	0	0	-1	0	0	
W 61st St		10	WB	0	0	0	0	0	
10th Ave		10	NB	0	0	-11	0	0	
10th Ave		10	SB	0	0	0	0	0	-12

W 61st St and Columbus Ave									
2019 (TMC-052)	11								
-	11	EB	0	0	0	0	0	0	
W 61st St	11	WB	0	0	0	0	0	0	
Columbus Ave	11	NB	0	0	0	0	0	0	
Columbus Ave	11	SB	0	-1	-6	0	0	0	-7
W 61st St and Broadway									
2019 (TMC-053)	12								
W 61st St	12	EB	0	0	-1	0	0	0	
W 61st St	12	WB	0	0	0	0	0	0	
Broadway	12	NB	0	0	-4	0	0	0	
Broadway	12	SB	0	0	-5	0	0	0	-10
Central Park and W 61st St									
2019 (TMC-054)	13								
W 61st St	13	EB	0	-1	0	0	0	0	
-	13	WB	0	0	0	0	0	0	
Central Park	13	NB	0	0	-12	0	0	0	
Central Park	13	SB	0	0	0	0	0	0	-13
Central Park and W 81st St									
2019 (TMC-055)	14								
W 81st St	14	EB	0	0	-1	0	0	0	
W 79th St Transverse	14	WB	0	-2	-5	-3	0	0	
Central Park	14	NB	0	0	0	0	0	0	
Central Park	14	SB	0	0	1	0	0	0	-10
Central Park West and W 66th St									
2019 (TMC-056)	15								
W 66th St	15	EB	0	0	0	0	0	0	
W 66th St	15	WB	0	-1	-5	-3	0	0	
Central Park West	15	NB	0	0	-1	0	0	0	
Central Park West	15	SB	0	0	-7	0	0	0	-17
Central Park West and W 65th St									
2019 (TMC-057)	16								
W 65th St	16	EB	0	0	-1	0	0	0	
W 65th St	16	WB	0	0	0	0	0	0	
Central Park West	16	NB	0	0	-1	0	0	0	
Central Park West	16	SB	0	-3	-5	0	0	0	-10

CBD Tolling
9A - Traffic Flowmap
AM No Action



- Legend:**
- Intersection (2019 Collected Data)
 - Intersection (Uncollected Data)
 - 100 - ATR Volume
 - 100 - Approach Volume

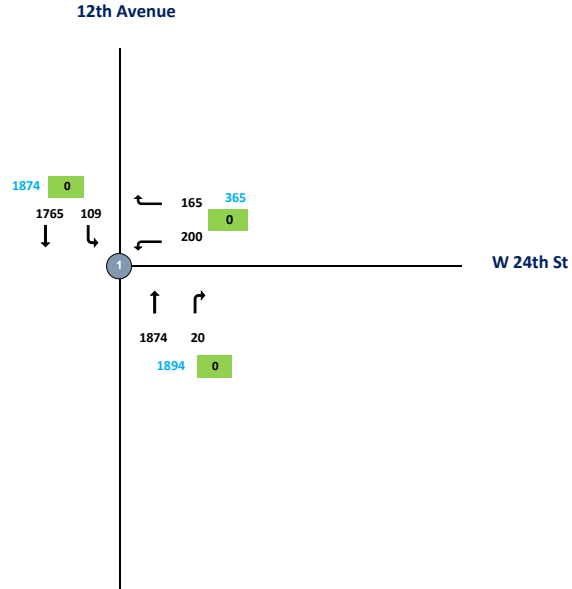

9A

8:00 AM

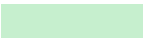

Intersection	Node	Approach	Total Vehicles					
			Inbound/Outbound					
			AM Peak Hour					
			L2	L	T	R	R2	Total
12th Ave & 24th Street 2019 (TMC-065)	1							
24th Street	1	EB	0	0	0	0	0	
24th Street	1	WB	0	200	0	165	0	
12th Ave	1	NB	0	0	1874	20	0	
12th Ave	1	SB	0	109	1765	0	0	4133

CBD Tolling
9A - Traffic Flowmap
MD No Action



- Legend:**
- Intersection (2019 Collected Data)
 - Intersection (Uncollected Data)
 - ATR Volume
 - Approach Volume

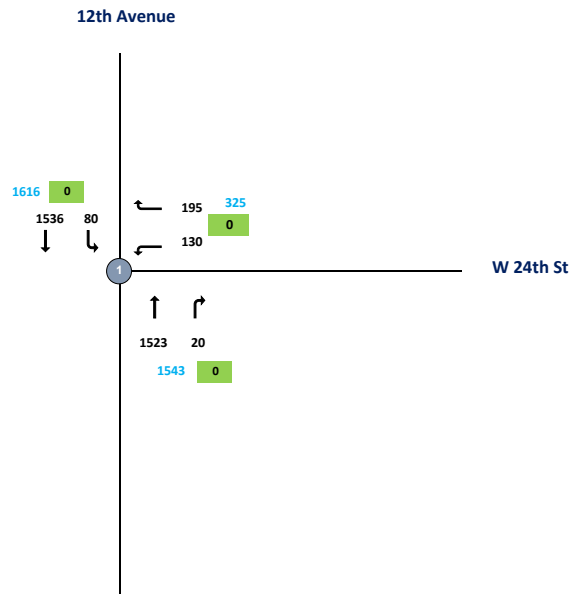

9A

1:00 PM

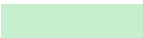

Intersection	Node	Approach	Total Vehicles					
			Inbound/Outbound					
			MD Peak Hour					
			L2	L	T	R	R2	Total
12th Ave & 24th Street 2019 (TMC-065)	1							
24th Street	1	EB	0	0	0	0	0	
24th Street	1	WB	0	130	0	195	0	
12th Ave	1	NB	0	0	1523	20	0	
12th Ave	1	SB	0	80	1536	0	0	3484

CBD Tolling
9A - Traffic Flowmap
PM No Action



- Legend:**
- Intersection (2019 Collected Data)
 - Intersection (Uncollected Data)
 - ATR Volume
 - Approach Volume

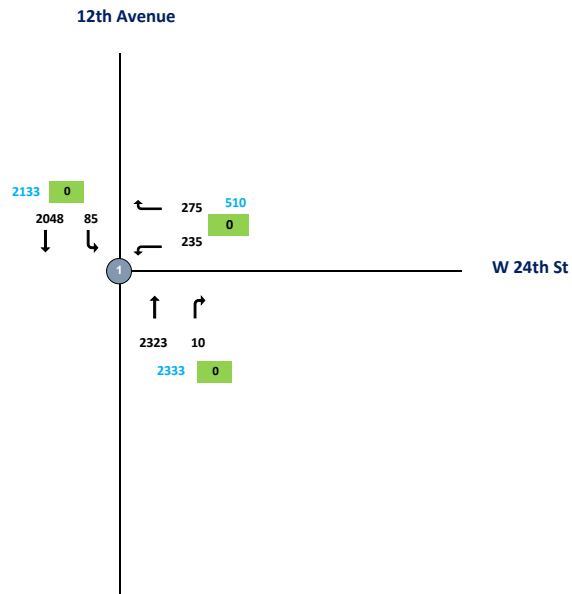

9A

5:00 PM

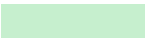

Intersection	Node	Approach	Total Vehicles					
			Inbound/Outbound					
			PM Peak Hour					
			L2	L	T	R	R2	Total
12th Ave & 24th Street 2019 (TMC-065)	1							
24th Street	1	EB	0	0	0	0	0	
24th Street	1	WB	0	235	0	275	0	
12th Ave	1	NB	0	0	2323	10	0	
12th Ave	1	SB	0	85	2048	0	0	4976

CBD Tolling
9A - Traffic Flowmap
LN No Action



- Legend:**
- Intersection (2019 Collected Data)
 - Intersection (Uncollected Data)
 - ATR Volume
 - Approach Volume

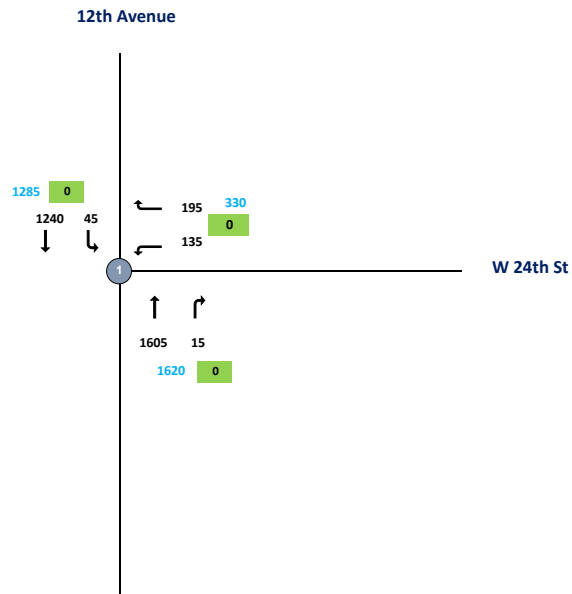

9A

9:00 PM

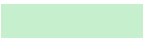

Intersection	Node	Approach	Total Vehicles					
			Inbound/Outbound					
			LN Peak Hour					
			L2	L	T	R	R2	Total
12th Ave & 24th Street 2019 (TMC-065)	1							
24th Street	1	EB	0	0	0	0	0	
24th Street	1	WB	0	135	0	195	0	
12th Ave	1	NB	0	0	1605	15	0	
12th Ave	1	SB	0	45	1240	0	0	3235

CBD Tolling
Dumbo #1- Traffic Flowmap
AM No Action



- Legend:**
- 1 - Intersection (2019 Collected Data)
 - 7 - Intersection (Uncollected Data)
 - 100 - ATR Volume
 - 100 - Approach Volume

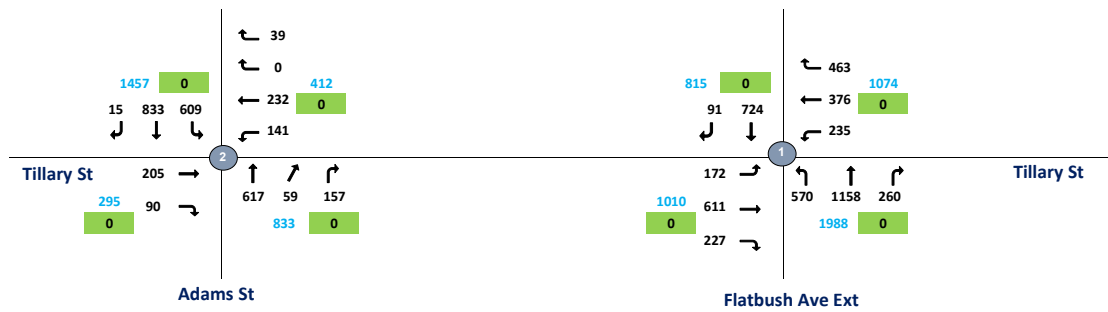

CBD Tolling
Dumbo #2 - Traffic Flowmap
AM No Action



- Legend:**
- 1 - Intersection (2019 Collected Data)
 - 7 - Intersection (Uncollected Data)
 - 100 - ATR Volume
 - 100 - Approach Volume

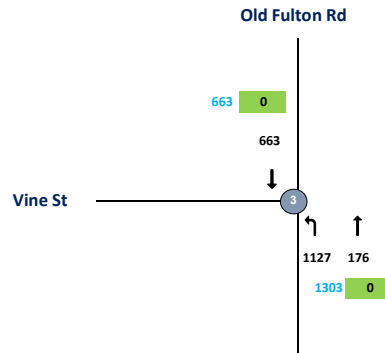

DUMBO

8:00:00 AM

Intersection	Node	Approach	Total Vehicles						
			Inbound/Outbound					Total	
			AM Peak Hour						
			L2	L	T	R	R2		
Tillary St & Flatbush Ave ext 2019 (TMC-007)	1								
Tillary St	1	EB	0	172	611	227	0		
Tillary St	1	WB	0	235	376	463	0		
Flatbush Ave ext	1	NB	0	570	1158	260	0		
Flatbush Ave ext	1	SB	0	0	724	91	0		4887
Tillary St & Adams St 2019 (TMC-008)	2								
Tillary St	2	EB	0	0	205	90	0		
Tillary St	2	WB	0	141	232	0	39		
Adams St	2	NB	0	0	617	59	157		
Adams St	2	SB	0	609	833	15	0		2997
Vine St & Old Fulton Rd 2019 (TMC-009)	3								
Vine St	3	EB	0	0	0	0	0		
Vine St	3	WB	0	0	0	0	0		
Old Fulton Rd	3	NB	0	1127	176	0	0		
Old Fulton Rd	3	SB	0	0	663	0	0		1966

CBD Tolling
Dumbo - Traffic Flowmap
MD No Action



- Legend:**
- 1 - Intersection (2019 Collected Data)
 - 7 - Intersection (Uncollected Data)
 - 100 - ATR Volume
 - 100 - Approach Volume

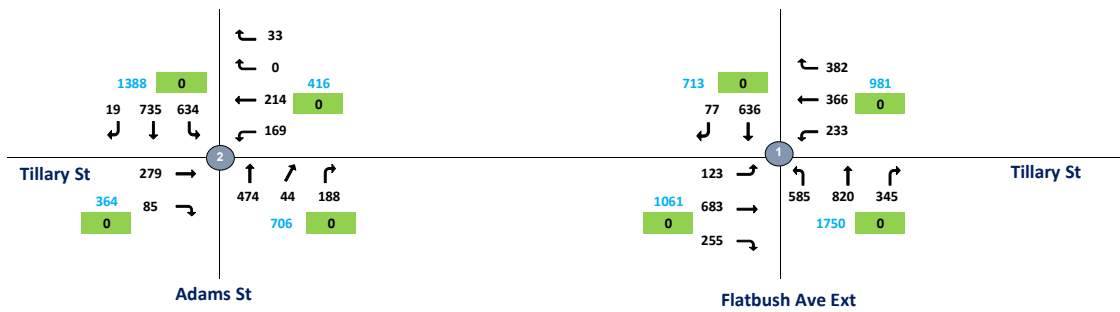

CBD Tolling
Dumbo #2 - Traffic Flowmap
MD No Action



- Legend:**
- 1 - Intersection (2019 Collected Data)
 - 7 - Intersection (Uncollected Data)
 - 100 - ATR Volume
 - 100 - Approach Volume

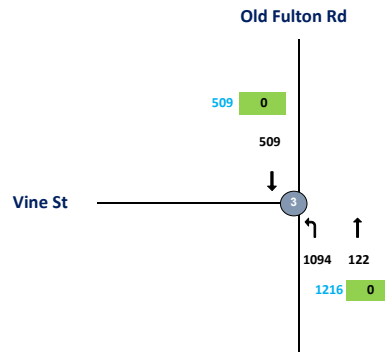

DUMBO

1:00:00 PM

Intersection	Node	Approach	Total Vehicles					Total
			Inbound/Outbound					
			MD Peak Hour					
			L2	L	T	R	R2	
Tillary St & Flatbush Ave ext 2019 (TMC-007)	1							
Tillary St	1	EB	0	123	683	255	0	
Tillary St	1	WB	0	233	366	382	0	
Flatbush Ave ext	1	NB	0	585	820	345	0	
Flatbush Ave ext	1	SB	0	0	636	77	0	4505
Tillary St & Adams St 2019 (TMC-008)	2							
Tillary St	2	EB	0	0	279	85	0	
Tillary St	2	WB	0	169	214	0	33	
Adams St	2	NB	0	0	474	44	188	
Adams St	2	SB	0	634	735	19	0	2874
Vine St & Old Fulton Rd 2019 (TMC-009)	3							
Vine St	3	EB	0	0	0	0	0	
Vine St	3	WB	0	0	0	0	0	
Old Fulton Rd	3	NB	0	1094	122	0	0	
Old Fulton Rd	3	SB	0	0	509	0	0	1725

CBD Tolling
Dumbo - Traffic Flowmap
PM No Action



- Legend:**
- 1 - Intersection (2019 Collected Data)
 - 7 - Intersection (Uncollected Data)
 - 100 - ATR Volume
 - 100 - Approach Volume

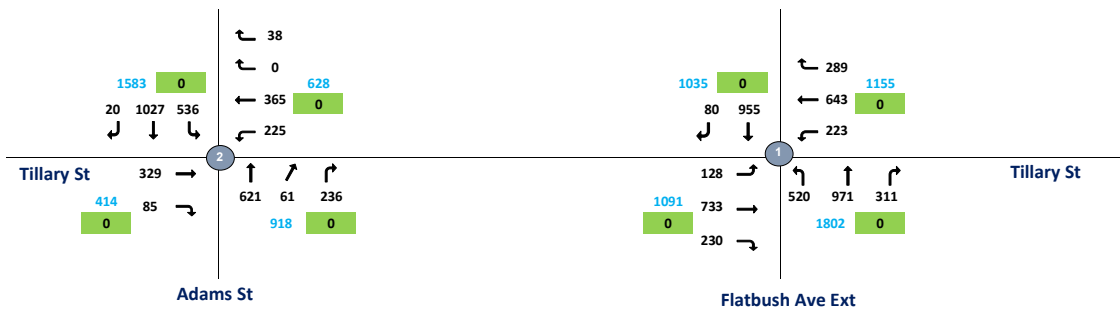

CBD Tolling
Dumbo #2 - Traffic Flowmap
PM No Action



- Legend:**
- 1 - Intersection (2019 Collected Data)
 - 7 - Intersection (Uncollected Data)
 - 100 - ATR Volume
 - 100 - Approach Volume

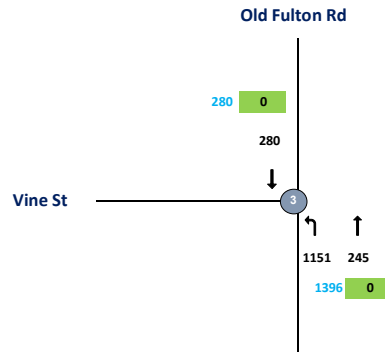

DUMBO

5:00:00 PM

Intersection	Node	Approach	Total Vehicles					Total
			Inbound/Outbound					
			PM Peak Hour					
			L2	L	T	R	R2	
Tillary St & Flatbush Ave ext 2019 (TMC-007)	1							
Tillary St	1	EB	0	128	733	230	0	
Tillary St	1	WB	0	223	643	289	0	
Flatbush Ave ext	1	NB	0	520	971	311	0	
Flatbush Ave ext	1	SB	0	0	955	80	0	5083
Tillary St & Adams St 2019 (TMC-008)	2							
Tillary St	2	EB	0	0	329	85	0	
Tillary St	2	WB	0	225	365	0	38	
Adams St	2	NB	0	0	621	61	236	
Adams St	2	SB	0	536	1027	20	0	3543
Vine St & Old Fulton Rd 2019 (TMC-009)	3							
Vine St	3	EB	0	0	0	0	0	
Vine St	3	WB	0	0	0	0	0	
Old Fulton Rd	3	NB	0	1151	245	0	0	
Old Fulton Rd	3	SB	0	0	280	0	0	1676

CBD Tolling
Dumbo - Traffic Flowmap
LN No Action



- Legend:**
- 1 - Intersection (2019 Collected Data)
 - 7 - Intersection (Uncollected Data)
 - 100 - ATR Volume
 - 100 - Approach Volume

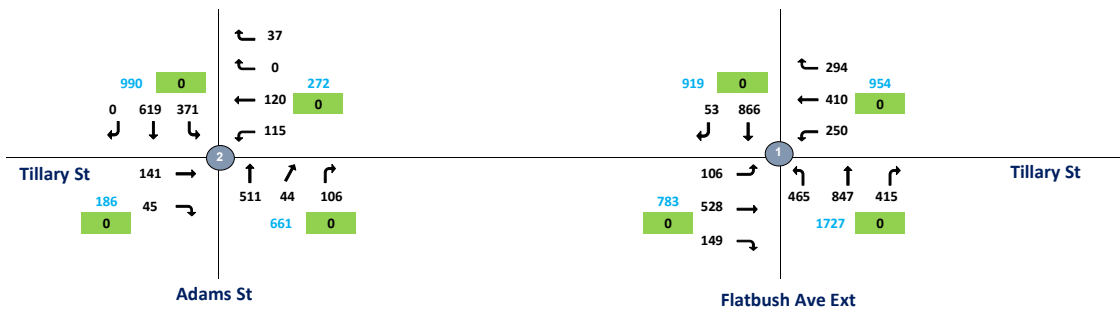

CBD Tolling
Dumbo #2 - Traffic Flowmap
LN No Action



- Legend:**
- 1 - Intersection (2019 Collected Data)
 - 7 - Intersection (Uncollected Data)
 - 100 - ATR Volume
 - 100 - Approach Volume

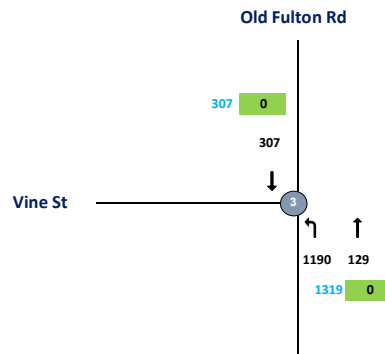

DUMBO

9:00:00 PM

Intersection	Node	Approach	Total Vehicles					Total
			Inbound/Outbound					
			LN Peak Hour					
			L2	L	T	R	R2	
Tillary St & Flatbush Ave ext 2019 (TMC-007)	1							
Tillary St	1	EB	0	106	528	149	0	
Tillary St	1	WB	0	250	410	294	0	
Flatbush Ave ext	1	NB	0	465	847	415	0	
Flatbush Ave ext	1	SB	0	0	866	53	0	4383
Tillary St & Adams St 2019 (TMC-008)	2							
Tillary St	2	EB	0	0	141	45	0	
Tillary St	2	WB	0	115	120	0	37	
Adams St	2	NB	0	0	511	44	106	
Adams St	2	SB	0	371	619	0	0	2109
Vine St & Old Fulton Rd 2019 (TMC-009)	3							
Vine St	3	EB	0	0	0	0	0	
Vine St	3	WB	0	0	0	0	0	
Old Fulton Rd	3	NB	0	1190	129	0	0	
Old Fulton Rd	3	SB	0	0	307	0	0	1626

CBD Tolling
LIC - Traffic Flowmap #1
AM No-Action



- Legend:**
- Intersection (2019 Collected Data)
 - Intersection (Uncollected Data)
 - 100 - ATR Volume
 - 100 - Approach Volume

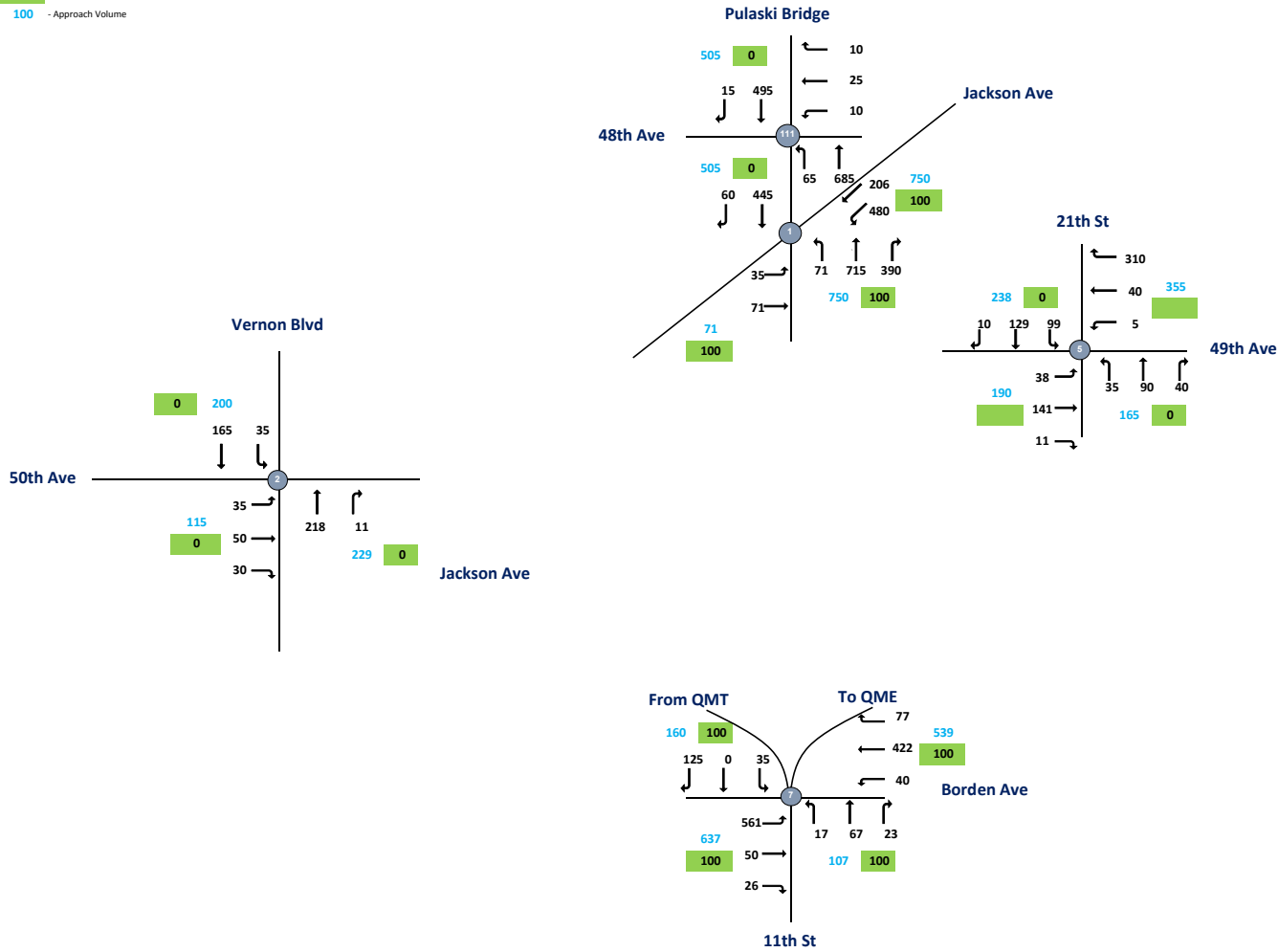

CBD Tolling
LIC - Traffic Flowmap #2
AM No-Action



- Legend:**
- Intersection (2019 Collected Data)
 - Intersection (Uncollected Data)
 - 100 - ATR Volume
 - 100 - Approach Volume

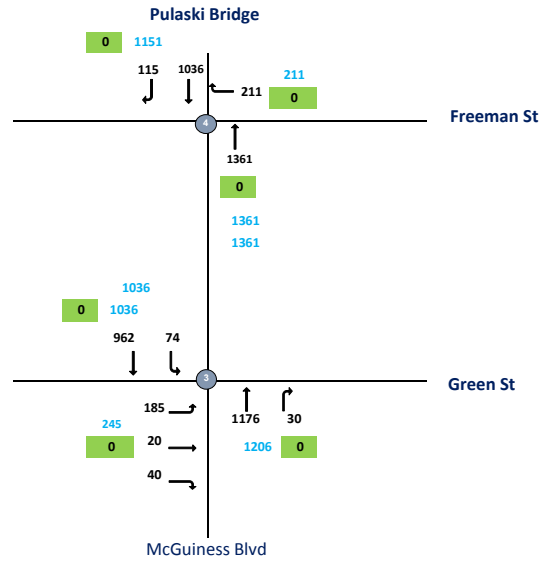

CBD Tolling
LIC - Traffic Flowmap #3
AM No-Action



- Legend:**
- Intersection (2019 Collected Data)
 - Intersection (Uncollected Data)
 - 100 - ATR Volume
 - 100 - Approach Volume

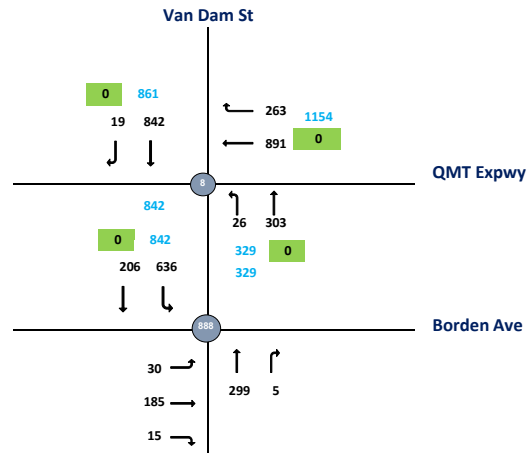

CBD Tolling
LIC - Traffic Flowmap #4
AM No-Action



- Legend:**
- ① - Intersection (2019 Collected Data)
 - ⑦ - Intersection (Uncollected Data)
 - 100 - ATR Volume
 - 100 - Approach Volume

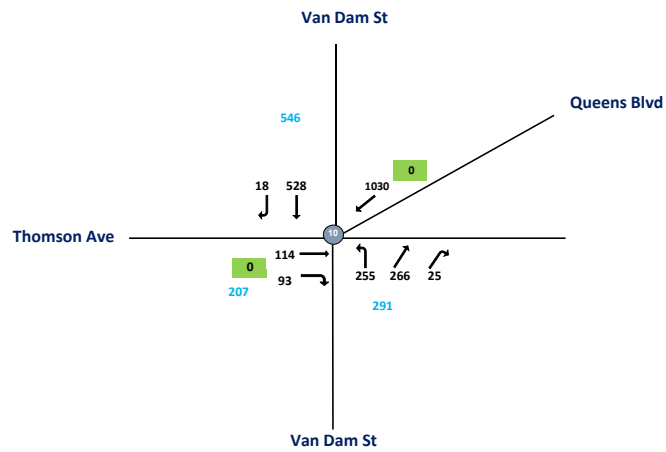
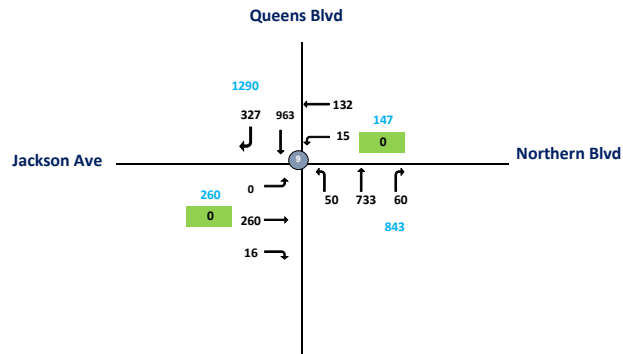

CBD Tolling
LIC - Traffic Flowmap #5
AM No-Action



- Legend:**
- Intersection (2019 Collected Data)
 - Intersection (Uncollected Data)
 - 100 - ATR Volume
 - 100 - Approach Volume

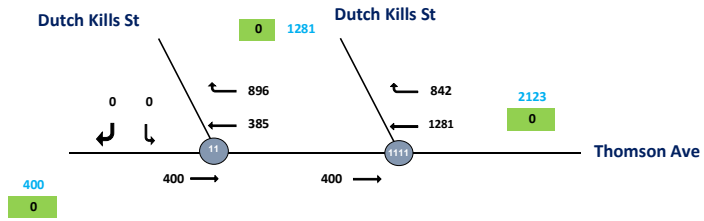

CBD Tolling
LIC - Traffic Flowmap #6
AM No-Action



- Legend:**
- Intersection (2019 Collected Data)
 - Intersection (Uncollected Data)
 - 100 - ATR Volume
 - 100 - Approach Volume

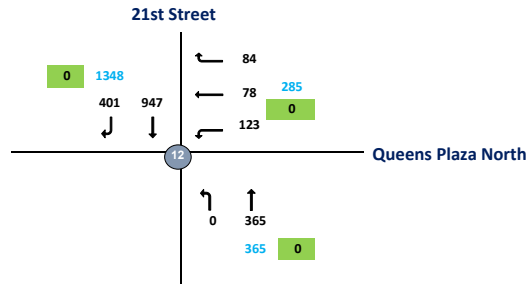

LIC

7:00:00 AM

Intersection	Node	Approach	Total Vehicles						
			Inbound/Outbound					Total	
			AM Peak Hour						
			L2	L	T	R	R2		
11th St / Pulaski Brdge & Jackson Ave 2017 --> 2019 (LIC_1_TMC-6A)	1								
Pulaski Bridge / 11th St	1	EB	0	35	71	0	0		
Pulaski Bridge / 11th St	1	WB	0	480	206	0	0		
Jackson Ave	1	NB	0	71	715	390	0		
Jackson Ave	1	SB	0	0	445	60	0	2473	
11th St / 48th St 2017 --> 2019 (LIC_1_TMC-6A)	111								
11th St	111	EB	0	0	0	0	0		
11th St	111	WB	0	10	25	10	0		
48th St	111	NB	0	65	685	0	0		
48th St	111	SB	0	0	495	15	0	1305	
Vernon Blvd & 50th Ave 2019 (TMC-001)	2								
50th Ave	2	EB	0	35	50	30	0		
50th Ave	2	WB	0	0	0	0	0		
Vernon Blvd	2	NB	0	0	218	11	0		
Vernon Blvd	2	SB	0	35	165	0	0	544	
Pulsaki Bridge & Green St 2019 (TMC-002)	3								
Green St	3	EB	0	185	20	40	0		
Green St	3	WB	0	0	0	0	0		
Pulsaki Bridge	3	NB	0	0	1176	30	0		
Pulsaki Btridge	3	SB	0	74	962	0	0	2487	
Pulsaki Bridge & Freeman St 2019 (TMC-003)	4								
Freeman St	4	EB	0	0	0	0	0		
Freeman St	4	WB	0	0	0	211	0		
Pulsaki Bridge	4	NB	0	0	1361	0	0		
Pulsaki Btridge	4	SB	0	0	1036	115	0	2723	
49th Ave & 21st St 2017 --> 2019 (LIC_5_TMC-6C)	5								
49th Ave	5	EB	0	38	141	11	0		
49th Ave	5	WB	0	5	40	310	0		
21th Ave	5	NB	0	35	90	40	0		
21th Ave	5	SB	0	99	129	10	0	948	
Borden Ave & 11th Street 2018 -- 2019 (LIC_7_TMC-6D)	7								
Borden Ave	7	EB	0	561	50	26	0		
Borden Ave	7	WB	0	40	422	77	0		
11th St	7	NB	0	17	67	23	0		
11th St	7	SB	0	35	0	125	0	1443	

Van Dam St & QMT Expwy (North) 2019 (TMC-004A)	8								
QMT Expwy	8	EB	0	0	0	0	0		
QMT Expwy	8	WB	0	0	891	263	0		
Van Dam St	8	NB	0	26	303	0	0		
Van Dam St	8	SB	0	0	842	19	0		2344
Van Dam St & QMT Expwy (South) 2019 (TMC-004B)	888								
QMT Expwy	888	EB	0	30	185	15	0		
QMT Expwy	888	WB	0	0	0	0	0		
Van Dam St	888	NB	0	0	299	5	0		
Van Dam St	888	SB	0	636	206	0	0		1376
Queens Blvd & Jackson Ave (Mainline) 2018 --> 2019 (LIC_9A_TMC-6E)	9								
Queens Blvd	9	EB	0	0	963	327	0		
Queens Blvd	9	WB	0	50	733	60	0		
Jackson Ave	9	NB	0	0	260	16	0		
Jackson Ave	9	SB	0	15	132	0	0		2556
Queens Blvd & Jackson Ave (Service Rd) 2018 --> 2019 (LIC_9A_TMC-6E)	9A								
Queens Blvd	9A	EB	0	0	35	355	0		
Queens Blvd	9A	WB	0	0	0	0	0		
Jackson Ave	9A	NB	0	0	0	0	0		
Jackson Ave	9A	SB	0	0	0	0	0		390
Thompson Ave & Queens Blvd 2018 --> 2019 (LIC_10_TMC-6G)	10								
Queens Blvd	10	EB	0	0	0	114	93		
Queens Blvd	10	WB	0	0	1030	0	0		
Thompson Ave	10	NB	0	255	266	0	25		
Thompson Ave	10	SB	0	0	528	18	0		2329
Dutch Kills St & Thomson Ave (#1) 2019 (TMC-005)	11								
Thomson Ave	11	EB	0	0	400	0	0		
Thomson Ave	11	WB	0	0	385	896	0		
Dutch Kills St	11	NB	0	0	0	0	0		
Dutch Kills St	11	SB	0	0	0	0	0		1681
Dutch Kills St & Thomson Ave (#2) 2019 (TMC-005)	1111								
Thomson Ave	1111	EB	0	0	400	0	0		
Thomson Ave	1111	WB	0	0	1281	842	0		
Dutch Kills St	1111	NB	0	0	0	0	0		
Dutch Kills St	1111	SB	0	0	0	0	0		2523
21st Street & Queens Plaza North 2019 (TMC-006)	12								
Queens Plaza North	12	EB	0	0	0	0	0		
Queens Plaza North	12	WB	0	123	78	84	0		
21st Street	12	NB	0	0	365	0	0		
21st Street	12	SB	0	0	947	401	0		1998

CBD Tolling
LIC - Traffic Flowmap #1
MD No-Action



- Legend:**
- 1 - Intersection (2019 Collected Data)
 - 7 - Intersection (Uncollected Data)
 - 100 - ATR Volume
 - 100 - Approach Volume

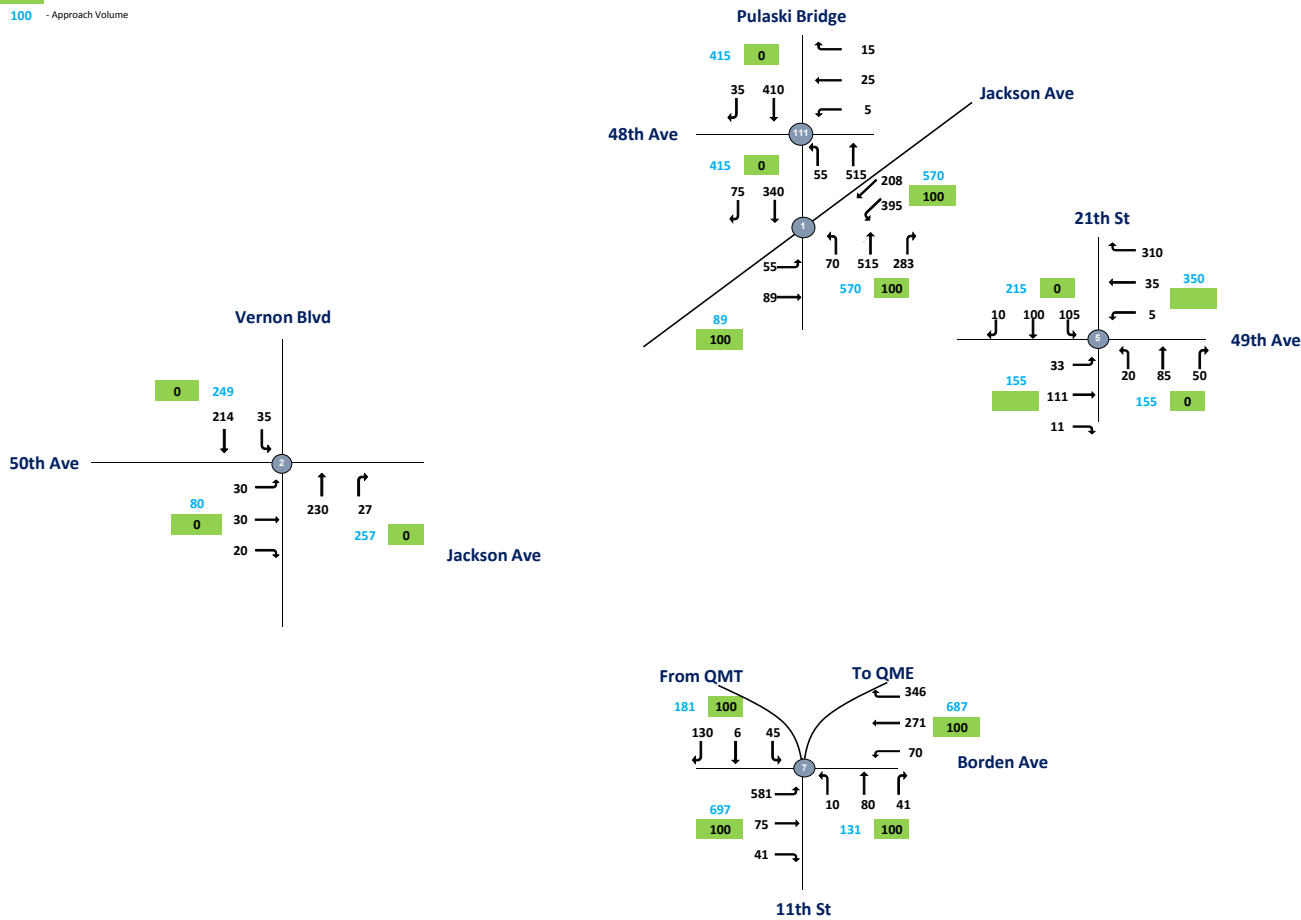

CBD Tolling
LIC - Traffic Flowmap #2
MD No-Action



- Legend:**
- Intersection (2019 Collected Data)
 - Intersection (Uncollected Data)
 - 100 - ATR Volume
 - 100 - Approach Volume

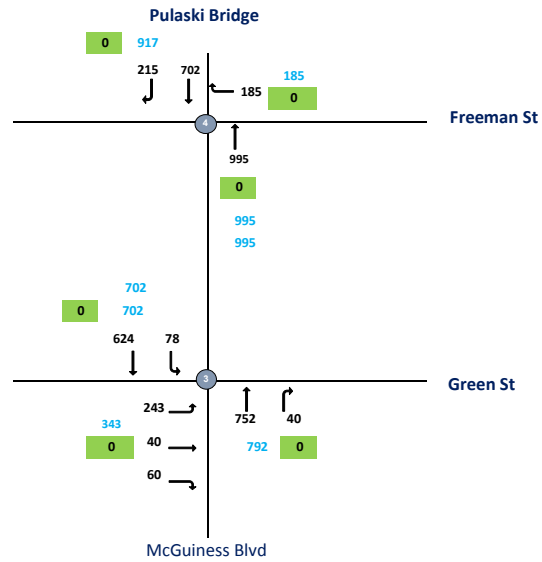

CBD Tolling
LIC - Traffic Flowmap #3
MD No-Action



- Legend:**
- Intersection (2019 Collected Data)
 - Intersection (Uncollected Data)
 - 100 - ATR Volume
 - 100 - Approach Volume

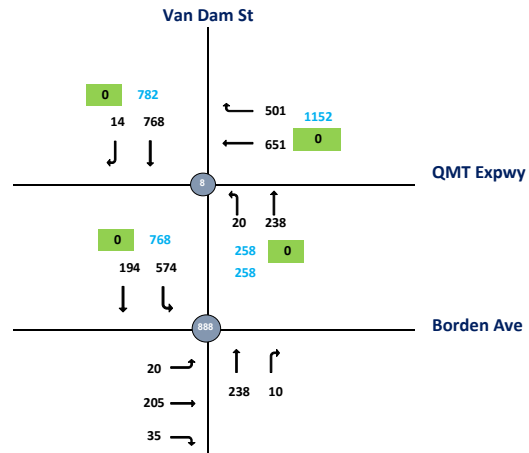

CBD Tolling
LIC - Traffic Flowmap #4
MD No-Action



- Legend:**
- 1 - Intersection (2019 Collected Data)
 - 7 - Intersection (Uncollected Data)
 - 100 - ATR Volume
 - 100 - Approach Volume

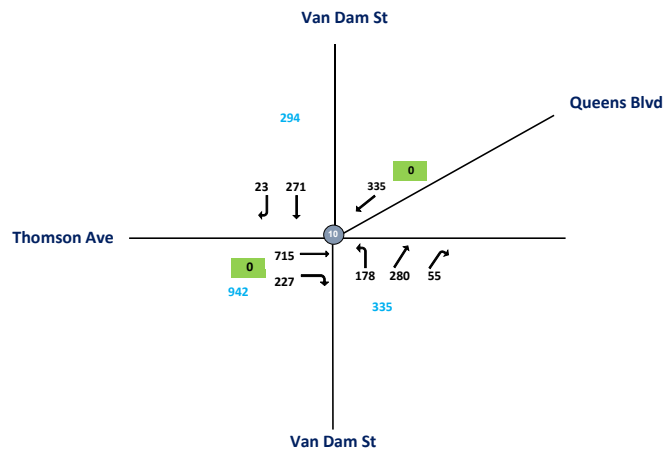
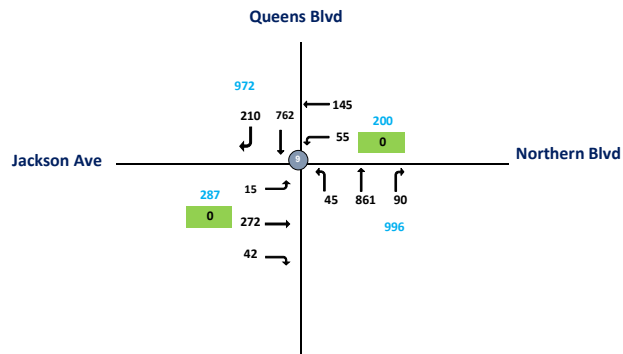

CBD Tolling
LIC - Traffic Flowmap #5
MD No-Action



- Legend:**
- Intersection (2019 Collected Data)
 - Intersection (Uncollected Data)
 - 100 - ATR Volume
 - 100 - Approach Volume

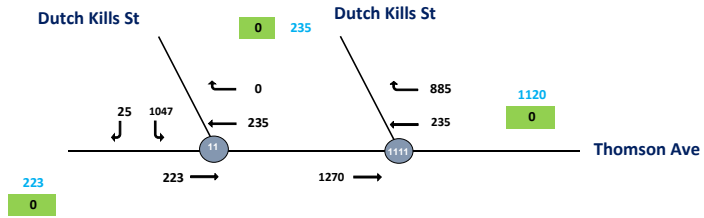

CBD Tolling
LIC - Traffic Flowmap #6
MD No-Action



- Legend:**
- Intersection (2019 Collected Data)
 - Intersection (Uncollected Data)
 - 100 - ATR Volume
 - 100 - Approach Volume

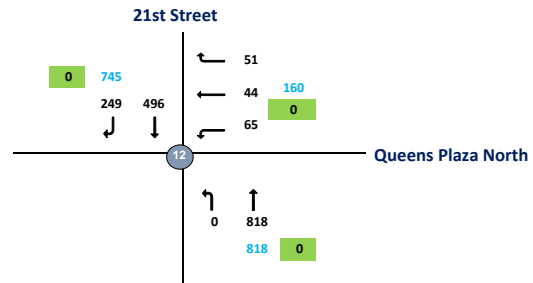

LIC

1:00:00 PM

Intersection	Node	Approach	Total Vehicles					
			Inbound/Outbound					Total
			MD Peak Hour					
L2	L	T	R	R2				
11th St / Pulaski Brdge & Jackson Ave 2017 --> 2019 (LIC_1_TMC-6A)	1							
Pulaski Bridge / 11th St	1	EB	0	55	89	0	0	
Pulaski Bridge / 11th St	1	WB	0	395	208	0	0	
Jackson Ave	1	NB	0	70	515	283	0	
Jackson Ave	1	SB	0	0	340	75	0	2030
11th St / 48th St 2017 --> 2019 (LIC_1_TMC-6A)	111							
11th St	111	EB	0	0	0	0	0	
11th St	111	WB	0	5	25	15	0	
48th St	111	NB	0	55	515	0	0	
48th St	111	SB	0	0	410	35	0	1060
Vernon Blvd & 50th Ave 2019 (TMC-001)	2							
50th Ave	2	EB	0	30	30	20	0	
50th Ave	2	WB	0	0	0	0	0	
Vernon Blvd	2	NB	0	0	230	27	0	
Vernon Blvd	2	SB	0	35	214	0	0	586
Pulsaki Bridge & Green St 2019 (TMC-002)	3							
Green St	3	EB	0	243	40	60	0	
Green St	3	WB	0	0	0	0	0	
Pulsaki Bridge	3	NB	0	0	752	40	0	
Pulsaki Btridge	3	SB	0	78	624	0	0	1837
Pulsaki Bridge & Freeman St 2019 (TMC-003)	4							
Freeman St	4	EB	0	0	0	0	0	
Freeman St	4	WB	0	0	0	185	0	
Pulsaki Bridge	4	NB	0	0	995	0	0	
Pulsaki Btridge	4	SB	0	0	702	215	0	2097
49th Ave & 21st St 2017 --> 2019 (LIC_5_TMC-6C)	5							
49th Ave	5	EB	0	33	111	11	0	
49th Ave	5	WB	0	5	35	310	0	
21th Ave	5	NB	0	20	85	50	0	
21th Ave	5	SB	0	105	100	10	0	875
Borden Ave & 11th Street 2018 -- 2019 (LIC_7_TMC-6D)	7							
Borden Ave	7	EB	0	581	75	41	0	
Borden Ave	7	WB	0	70	271	346	0	
11th St	7	NB	0	10	80	41	0	
11th St	7	SB	0	45	6	130	0	1696

Van Dam St & QMT Expwy (North) 2019 (TMC-004A)	8								
QMT Expwy	8	EB	0	0	0	0	0		
QMT Expwy	8	WB	0	0	651	501	0		
Van Dam St	8	NB	0	20	238	0	0		
Van Dam St	8	SB	0	0	768	14	0		2192
Van Dam St & QMT Expwy (South) 2019 (TMC-004B)	888								
QMT Expwy	888	EB	0	20	205	35	0		
QMT Expwy	888	WB	0	0	0	0	0		
Van Dam St	888	NB	0	0	238	10	0		
Van Dam St	888	SB	0	574	194	0	0		1276
Queens Blvd & Jackson Ave (Mainline) 2018 --> 2019 (LIC_9A_TMC-6E)	9								
Queens Blvd	9	EB	0	0	762	210	0		
Queens Blvd	9	WB	0	45	861	90	0		
Jackson Ave	9	NB	0	15	272	42	0		
Jackson Ave	9	SB	0	55	145	0	0		2497
Queens Blvd & Jackson Ave (Service Rd) 2018 --> 2019 (LIC_9A_TMC-6E)	9A								
Queens Blvd	9A	EB	0	0	45	260	0		
Queens Blvd	9A	WB	0	0	0	0	0		
Jackson Ave	9A	NB	0	0	0	0	0		
Jackson Ave	9A	SB	0	0	0	0	0		305
Thompson Ave & Queens Blvd 2018 --> 2019 (LIC_10_TMC-6G)	10								
Queens Blvd	10	EB	0	0	0	715	227		
Queens Blvd	10	WB	0	0	335	0	0		
Thompson Ave	10	NB	0	178	280	0	55		
Thompson Ave	10	SB	0	0	271	23	0		2084
Dutch Kills St & Thomson Ave (#1) 2019 (TMC-005)	11								
Thomson Ave	11	EB	0	0	223	0	0		
Thomson Ave	11	WB	0	0	235	0	0		
Dutch Kills St	11	NB	0	0	0	0	0		
Dutch Kills St	11	SB	0	1047	0	25	0		1530
Dutch Kills St & Thomson Ave (#2) 2019 (TMC-005)	1111								
Thomson Ave	1111	EB	0	0	1270	0	0		
Thomson Ave	1111	WB	0	0	235	885	0		
Dutch Kills St	1111	NB	0	0	0	0	0		
Dutch Kills St	1111	SB	0	0	0	0	0		2390
21st Street & Queens Plaza North 2019 (TMC-006)	12								
Queens Plaza North	12	EB	0	0	0	0	0		
Queens Plaza North	12	WB	0	65	44	51	0		
21st Street	12	NB	0	0	818	0	0		
21st Street	12	SB	0	0	496	249	0		1723

CBD Tolling
LIC - Traffic Flowmap #1
AM No-Action



- Legend:**
- 1 - Intersection (2019 Collected Data)
 - 7 - Intersection (Uncollected Data)
 - 100 - ATR Volume
 - 100 - Approach Volume

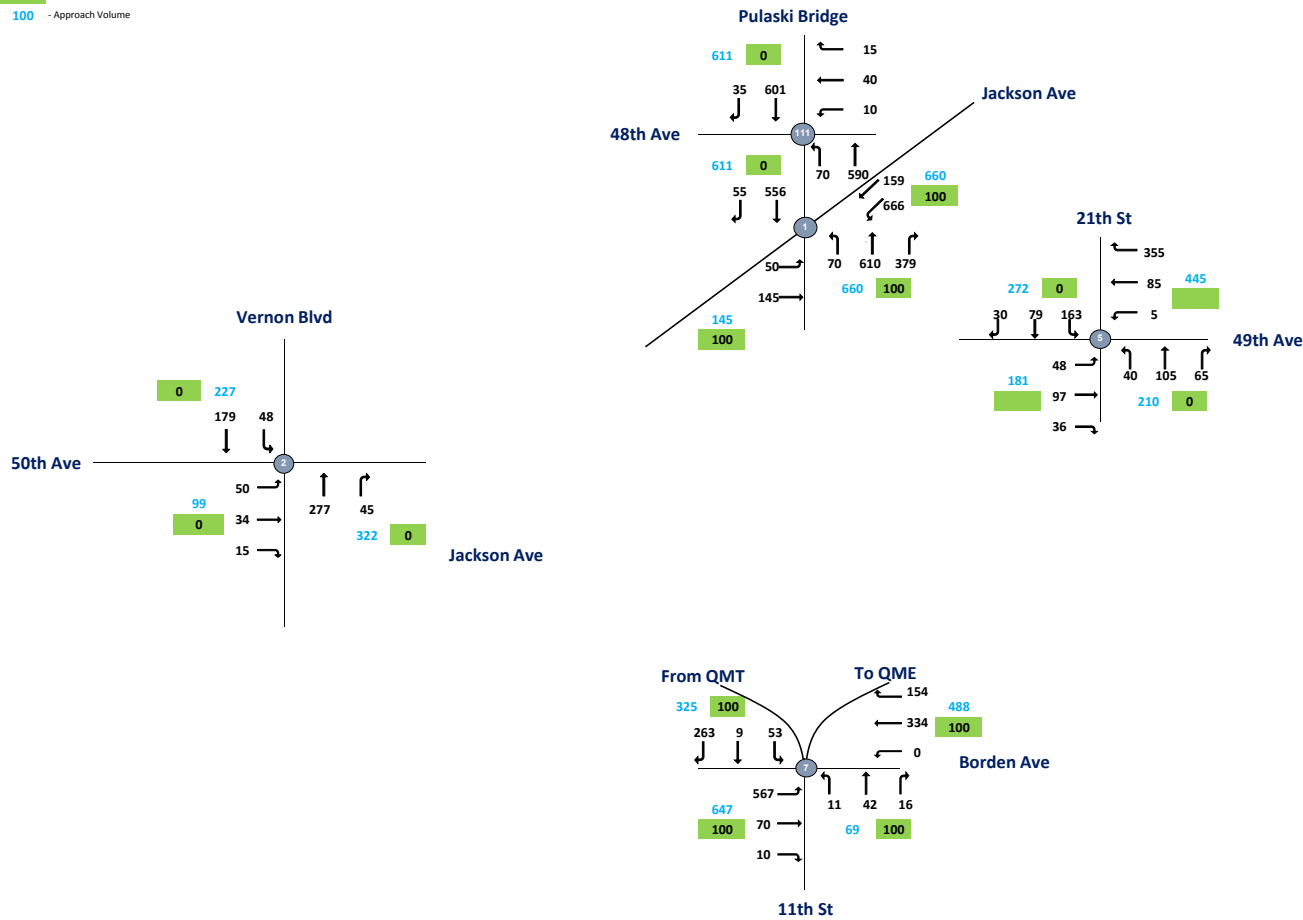

CBD Tolling
LIC - Traffic Flowmap #2
AM No-Action



- Legend:**
- Intersection (2019 Collected Data)
 - Intersection (Uncollected Data)
 - 100 - ATR Volume
 - 100 - Approach Volume

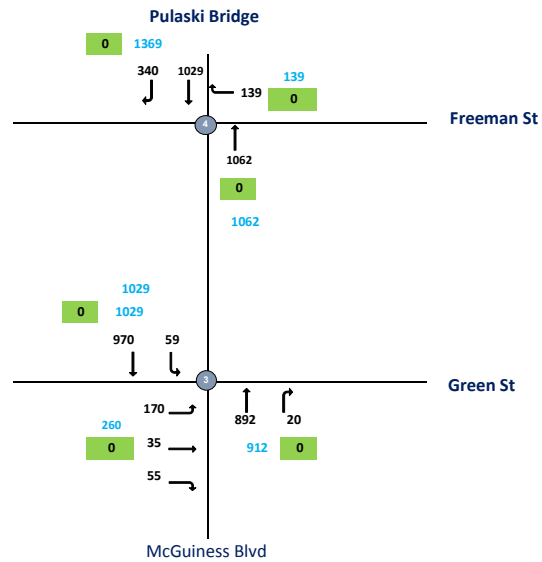

CBD Tolling
LIC - Traffic Flowmap #3
AM No-Action



- Legend:**
- Intersection (2019 Collected Data)
 - Intersection (Uncollected Data)
 - 100 - ATR Volume
 - 100 - Approach Volume

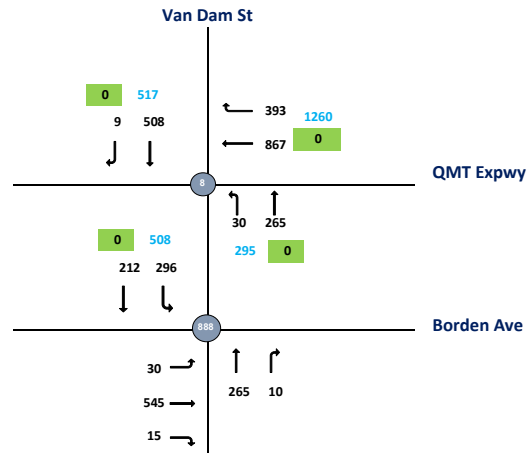

CBD Tolling
LIC - Traffic Flowmap #4
AM No-Action



- Legend:**
- 1 - Intersection (2019 Collected Data)
 - 7 - Intersection (Uncollected Data)
 - 100 - ATR Volume
 - 100 - Approach Volume

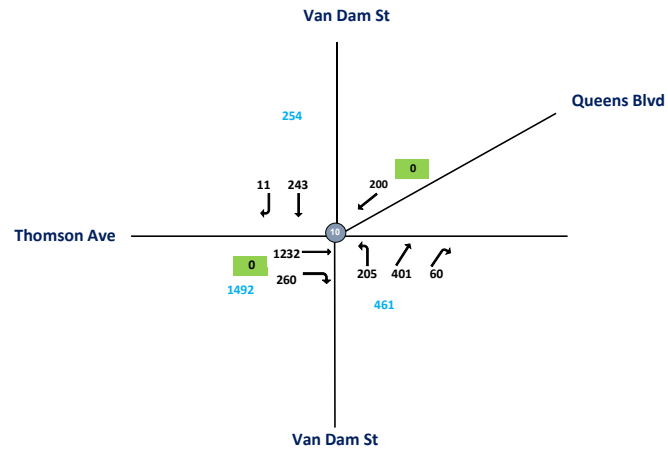
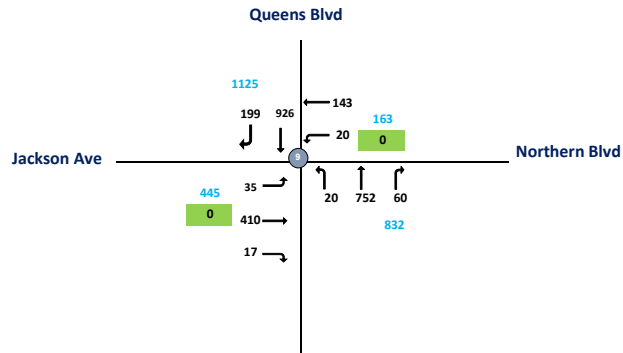

CBD Tolling
LIC - Traffic Flowmap #5
AM No-Action



- Legend:**
- Intersection (2019 Collected Data)
 - Intersection (Uncollected Data)
 - 100 - ATR Volume
 - 100 - Approach Volume

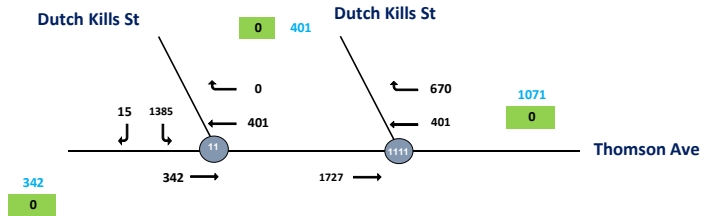

CBD Tolling
LIC - Traffic Flowmap #6
AM No-Action



- Legend:**
- Intersection (2019 Collected Data)
 - Intersection (Uncollected Data)
 - 100 - ATR Volume
 - 100 - Approach Volume

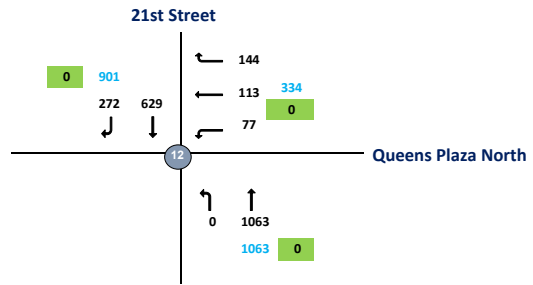

LIC

7:00:00 AM

Intersection	Node	Approach	Total Vehicles					
			Inbound/Outbound					Total
			AM Peak Hour					
L2	L	T	R	R2				
11th St / Pulaski Brdge & Jackson Ave 2017 --> 2019 (LIC_1_TMC-6A)	1							
Pulaski Bridge / 11th St	1	EB	0	35	71	0	0	
Pulaski Bridge / 11th St	1	WB	0	480	206	0	0	
Jackson Ave	1	NB	0	71	715	390	0	
Jackson Ave	1	SB	0	0	445	60	0	2473
11th St / 48th St 2017 --> 2019 (LIC_1_TMC-6A)	111							
11th St	111	EB	0	0	0	0	0	
11th St	111	WB	0	10	25	10	0	
48th St	111	NB	0	65	685	0	0	
48th St	111	SB	0	0	495	15	0	1305
Vernon Blvd & 50th Ave 2019 (TMC-001)	2							
50th Ave	2	EB	0	35	50	30	0	
50th Ave	2	WB	0	0	0	0	0	
Vernon Blvd	2	NB	0	0	218	11	0	
Vernon Blvd	2	SB	0	35	165	0	0	544
Pulsaki Bridge & Green St 2019 (TMC-002)	3							
Green St	3	EB	0	185	20	40	0	
Green St	3	WB	0	0	0	0	0	
Pulsaki Bridge	3	NB	0	0	1176	30	0	
Pulsaki Btridge	3	SB	0	74	962	0	0	2487
Pulsaki Bridge & Freeman St 2019 (TMC-003)	4							
Freeman St	4	EB	0	0	0	0	0	
Freeman St	4	WB	0	0	0	211	0	
Pulsaki Bridge	4	NB	0	0	1361	0	0	
Pulsaki Btridge	4	SB	0	0	1036	115	0	2723
49th Ave & 21st St 2017 --> 2019 (LIC_5_TMC-6C)	5							
49th Ave	5	EB	0	38	141	11	0	
49th Ave	5	WB	0	5	40	310	0	
21th Ave	5	NB	0	35	90	40	0	
21th Ave	5	SB	0	99	129	10	0	948
Borden Ave & 11th Street 2018 -- 2019 (LIC_7_TMC-6D)	7							
Borden Ave	7	EB	0	561	50	26	0	
Borden Ave	7	WB	0	40	422	77	0	
11th St	7	NB	0	17	67	23	0	
11th St	7	SB	0	35	0	125	0	1443

Van Dam St & QMT Expwy (North) 2019 (TMC-004A)	8								
QMT Expwy	8	EB	0	0	0	0	0		
QMT Expwy	8	WB	0	0	891	263	0		
Van Dam St	8	NB	0	26	303	0	0		
Van Dam St	8	SB	0	0	842	19	0		2344
Van Dam St & QMT Expwy (South) 2019 (TMC-004B)	888								
QMT Expwy	888	EB	0	30	185	15	0		
QMT Expwy	888	WB	0	0	0	0	0		
Van Dam St	888	NB	0	0	299	5	0		
Van Dam St	888	SB	0	636	206	0	0		1376
Queens Blvd & Jackson Ave (Mainline) 2018 --> 2019 (LIC_9A_TMC-6E)	9								
Queens Blvd	9	EB	0	0	963	327	0		
Queens Blvd	9	WB	0	50	733	60	0		
Jackson Ave	9	NB	0	0	260	16	0		
Jackson Ave	9	SB	0	15	132	0	0		2556
Queens Blvd & Jackson Ave (Service Rd) 2018 --> 2019 (LIC_9A_TMC-6E)	9A								
Queens Blvd	9A	EB	0	0	35	355	0		
Queens Blvd	9A	WB	0	0	0	0	0		
Jackson Ave	9A	NB	0	0	0	0	0		
Jackson Ave	9A	SB	0	0	0	0	0		390
Thompson Ave & Queens Blvd 2018 --> 2019 (LIC_10_TMC-6G)	10								
Queens Blvd	10	EB	0	0	0	114	93		
Queens Blvd	10	WB	0	0	1030	0	0		
Thompson Ave	10	NB	0	255	266	0	25		
Thompson Ave	10	SB	0	0	528	18	0		2329
Dutch Kills St & Thomson Ave (#1) 2019 (TMC-005)	11								
Thomson Ave	11	EB	0	0	400	0	0		
Thomson Ave	11	WB	0	0	385	896	0		
Dutch Kills St	11	NB	0	0	0	0	0		
Dutch Kills St	11	SB	0	0	0	0	0		1681
Dutch Kills St & Thomson Ave (#2) 2019 (TMC-005)	1111								
Thomson Ave	1111	EB	0	0	400	0	0		
Thomson Ave	1111	WB	0	0	1281	842	0		
Dutch Kills St	1111	NB	0	0	0	0	0		
Dutch Kills St	1111	SB	0	0	0	0	0		2523
21st Street & Queens Plaza North 2019 (TMC-006)	12								
Queens Plaza North	12	EB	0	0	0	0	0		
Queens Plaza North	12	WB	0	123	78	84	0		
21st Street	12	NB	0	0	365	0	0		
21st Street	12	SB	0	0	947	401	0		1998

CBD Tolling
LM - Traffic Flowmap #1
AM No-Action



- Legend:**
- 1 - Intersection (2019 Collected Data)
 - 7 - Intersection (Uncollected Data)
 - 100 - ATR Volume
 - 100 - Approach Volume

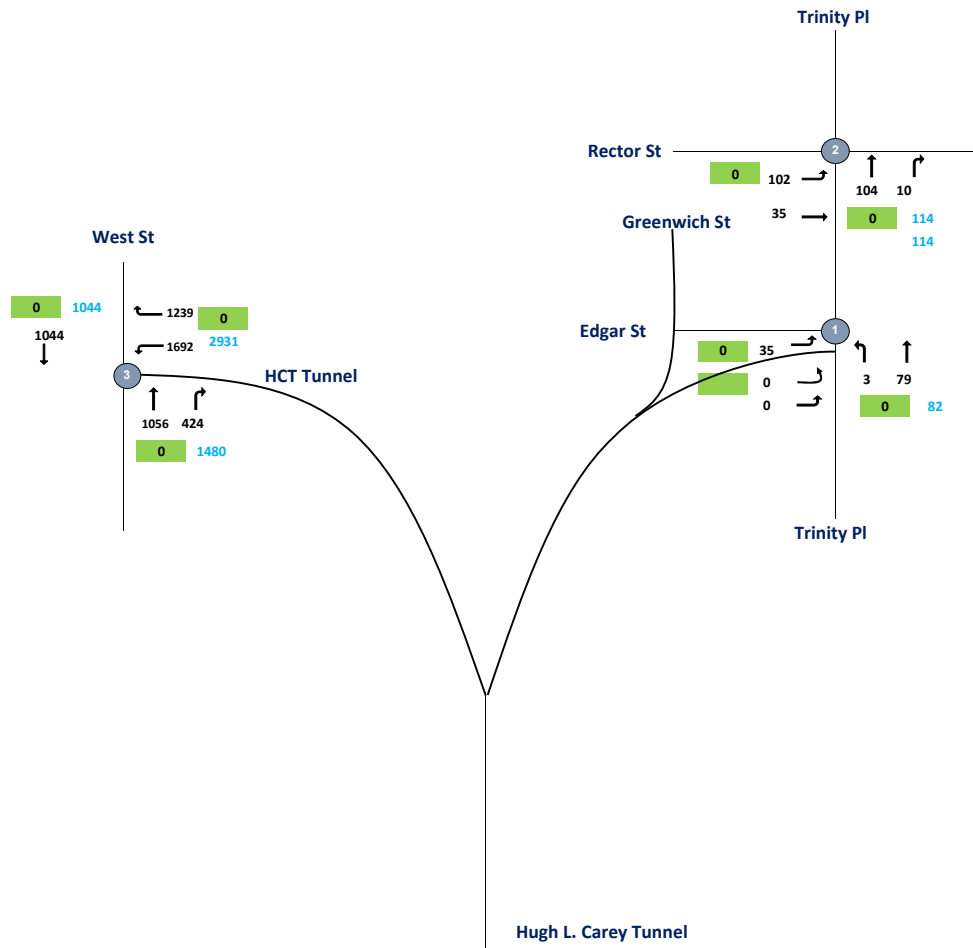

CBD Tolling
LM - Traffic Flowmap #2
AM No-Action

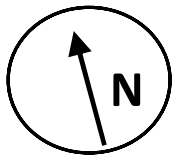

Legend:

1 - Intersection (2019 Collected Data)

7 - Intersection (Uncollected Data)

100 - ATR Volume

100 - Approach Volume

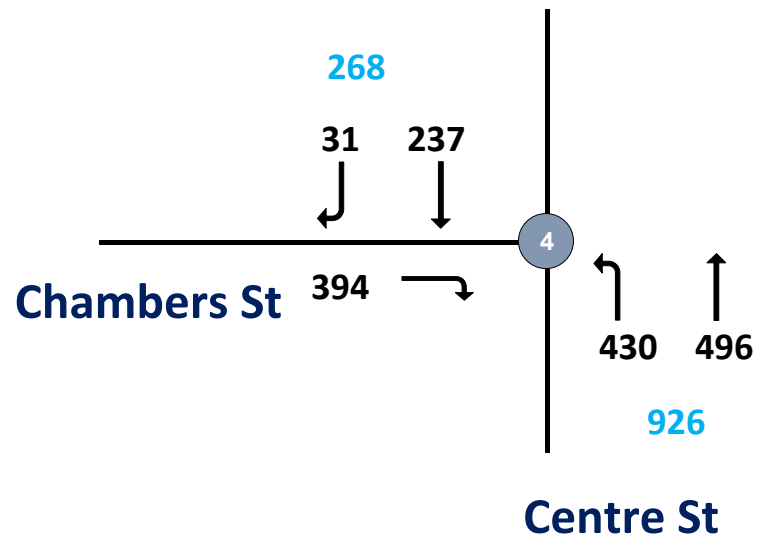

CBD Tolling
LM - Traffic Flowmap #4
AM No-Action



- Legend:
- 1 - Intersection (2019 Collected Data)
 - 2 - Intersection (Uncollected Data)
 - 100 - ATR Volume
 - 100 - Approach Volume

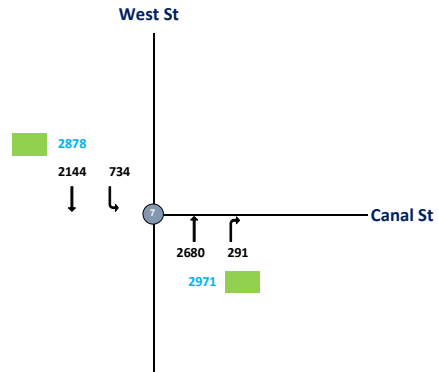

CBD Tolling
LM - Traffic Flowmap #5
AM No-Action



- Legend:**
- Intersection (2019 Collected Data)
 - Intersection (Uncollected Data)
 - 100 - ATR Volume
 - 100 - Approach Volume

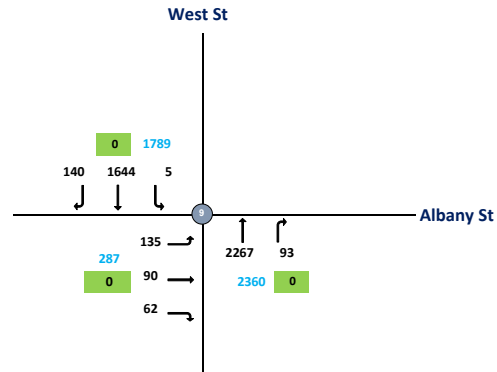

CBD Tolling
LM - Traffic Flowmap #6
AM No-Action



- Legend:**
- 1 - Intersection (2019 Collected Data)
 - 7 - Intersection (Uncollected Data)
 - 100 - ATR Volume
 - 100 - Approach Volume
 - ↯ - Illegal movement

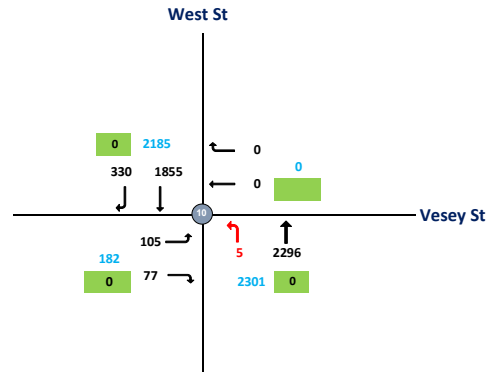

CBD Tolling
LM - Traffic Flowmap #7
AM No-Action



- Legend:**
- 1 - Intersection (2019 Collected Data)
 - 7 - Intersection (Uncollected Data)
 - 100 - ATR Volume
 - 100 - Approach Volume

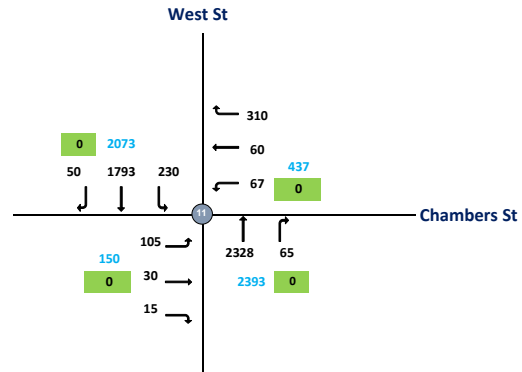

CBD Tolling
LM - Traffic Flowmap #8
AM No-Action



- Legend:**
- Intersection (2019 Collected Data)
 - Intersection (Uncollected Data)
 - ATR Volume
 - Approach Volume

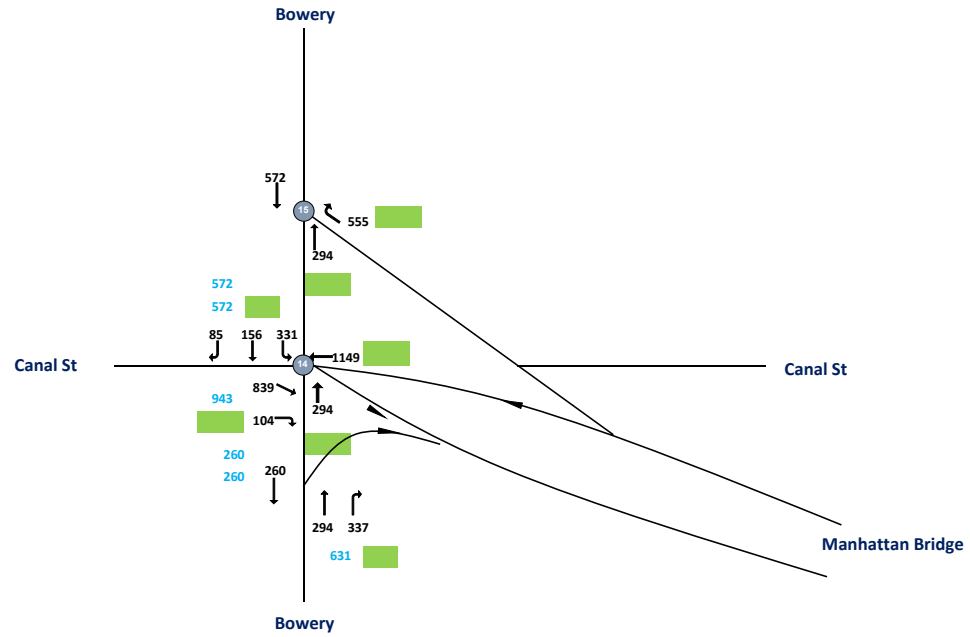

Intersection	Node	Approach	Total Vehicles						
			Inbound/Outbound						
			AM Peak Hour						
			L2	L	T	R	R2	Total	
Edgar St. and Trinity Pl. 2019 (TMC-010)	1								
Edgar St.	1	EB	0	35	0	0	0		
478 Exit Ramp.	1	NE	0	0	0	0	0		
Trinity Pl.	1	NB	0	3	79	0	0		
Trinity Pl.	1	SB	0	0	0	0	0		117
Rector St. and Trinity Pl. 2019 (TMC-011)	2								
Rector St.	2	EB	0	102	35	0	0		
Rector St.	2	WB	0	0	0	0	0		
Trinity Pl.	2	NB	0	0	104	10	0		
Trinity Pl.	2	SB	0	0	0	0	0		251
West St. and HCT Exit. 2019 (TMC-012)	3								
-	3	EB	0	0	0	0	0		
HCT Exit.	3	WB	0	1692	0	0	0		
West St.	3	NB	0	0	1056	0	424		
West St.	3	SB	0	0	1044	0	0		4216
West St. and HCT Exit. 2019 (TMC-012)	333								
W. Thams St.	333	EB	0	0	0	0	0		
HCT Exit.	333	WB	0	0	0	1239	0		
West St.	333	NB	0	0	1056	0	0		
West St.	333	SB	0	0	1044	0	0		3339
Chambers St. and Centre St. 2018	4								
Chambers St.	4	EB	0	0	0	394	0		
-	4	WB	0	0	0	0	0		
Centre St.	4	NB	0	430	496	0	0		
Centre St.	4	SB	0	0	237	31	0		1588
Hudson St. and Canal St. 2018	5								
Canal St.	5	EB	50	438	589	0	0		
Canal St.	5	WB	0	0	409	89	0		
Hudson St.	5	NB	0	105	670	190	46		
Hudson St.	5	SB	0	0	0	0	0		2586

Hudson St. and Canal St.								
2018	555							
Canal St.	555	EB	0	0	635	0	0	
Canal St.	555	WB	0	0	498	880	0	
Hudson St.	555	NB	0	0	0	0	0	
Hudson St.	555	SB	0	0	0	0	0	2013
West St. and Canal St N.								
2018	7							
Canal St N.	7	EB	0	0	0	0	0	
-	7	WB	0	0	0	0	0	
West St.	7	NB	0	0	2680	291	0	
West St.	7	SB	0	734	2144	0	0	5849
West St. and Canal St S.								
2018	777							
-	777	EB	0	0	0	0	0	
Canal St S.	777	WB	0	0	0	0	0	
West St.	777	NB	0	0	2680	0	0	
West St.	777	SB	0	0	2878	0	0	5558
West St. and Albany St.								
2019 (TMC-013)	9							
Albany St.	9	EB	0	135	90	62	0	
-	9	WB	0	0	0	0	0	
West St.	9	NB	0	0	2267	93	0	
West St.	9	SB	0	5	1644	140	0	4436
West St. and Vesey St.								
2019 (TMC-014)	10							
Vesey St.	10	EB	0	105	0	77	0	
Vesey St.	10	WB	0	0	0	0	0	
West St.	10	NB	0	5	2296	0	0	
West St.	10	SB	0	0	1855	330	0	117
West St. and Chambers St.								
2019 (TMC-015)	11							
Chambers St.	11	EB	0	105	30	15	0	
Chambers St.	11	WB	0	67	60	310	0	
West St.	11	NB	0	0	2328	65	0	
West St.	11	SB	0	230	1793	50	0	5053

Bowey and Canal St./Manhattan Bridge Off-Ramp								
2018	14							
Canal St.	14	EB	0	0	839	104	0	
Manhattan Bridge Off-Ramp	14	WB	0	0	1149	0	0	
Bowey	14	NB	0	0	294	337	0	
Bowey	14	SB	0	331	156	85	0	3295
Bowey and Manhattan Bridge Off-Ramp								
2018	15							
	15	EB	0	0	0	0	0	
Manhattan Bridge Off-Ramp	15	WB	0	0	0	555	0	
Bowey	15	NB	0	0	294	0	0	
Bowey	15	SB	0	0	572	0	0	1421
6th Ave. and Watts St								
2018	18							
Watts St	18	EB	0	0	0	0	0	
Watts St	18	WB	0	0	776	25	0	
6th Ave.	18	NB	0	86	997	0	0	
6th Ave.	18	SB	0	0	0	0	0	1884
6th Ave. and Canal St.								
2018	19							
Canal St.	19	EB	0	0	657	0	0	
Canal St.	19	WB	0	0	1217	265	0	
6th Ave.	19	NB	0	168	694	4	0	
Laight St.	19	NE	0	0	0	629	0	3634

CBD Tolling
LM - Traffic Flowmap #1
MD No Action



- Legend:**
- 1 - Intersection (2019 Collected Data)
 - 7 - Intersection (Uncollected Data)
 - 100 - ATR Volume
 - 100 - Approach Volume

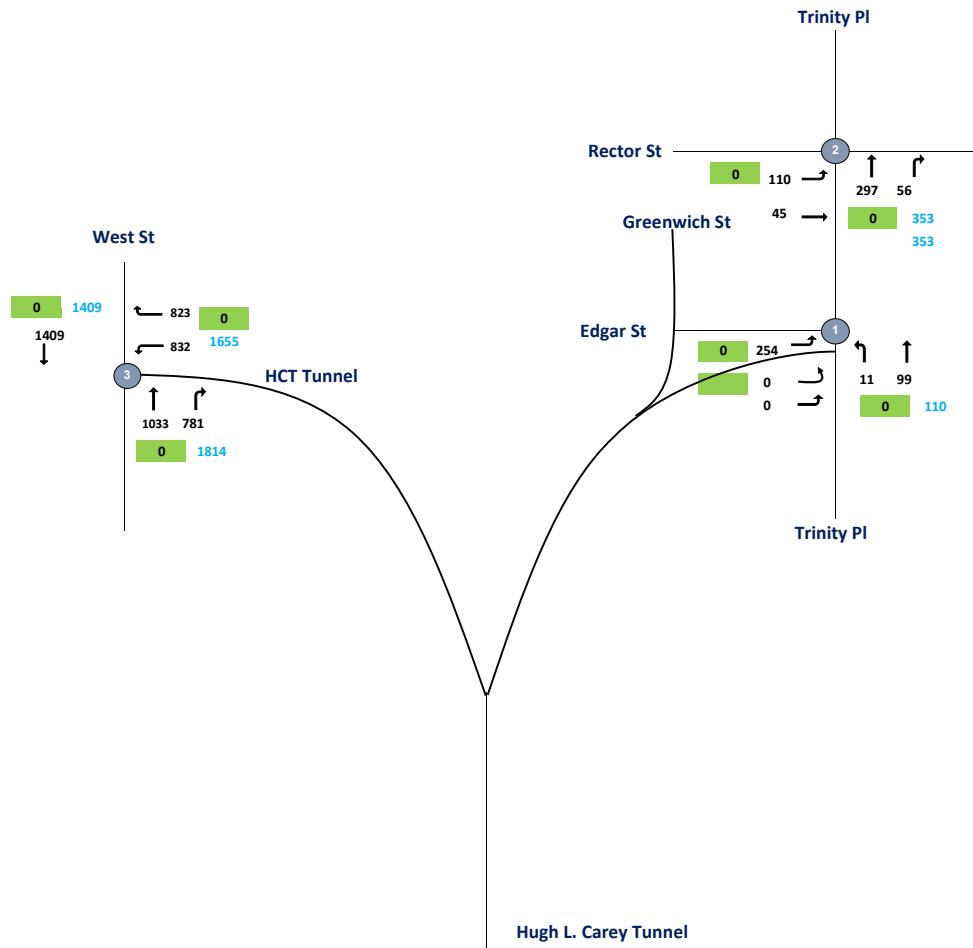

CBD Tolling
LM - Traffic Flowmap #2
MD No Action



- Legend:**
- 1 - Intersection (2019 Collected Data)
 - 7 - Intersection (Uncollected Data)
 - 100 - ATR Volume
 - 100 - Approach Volume

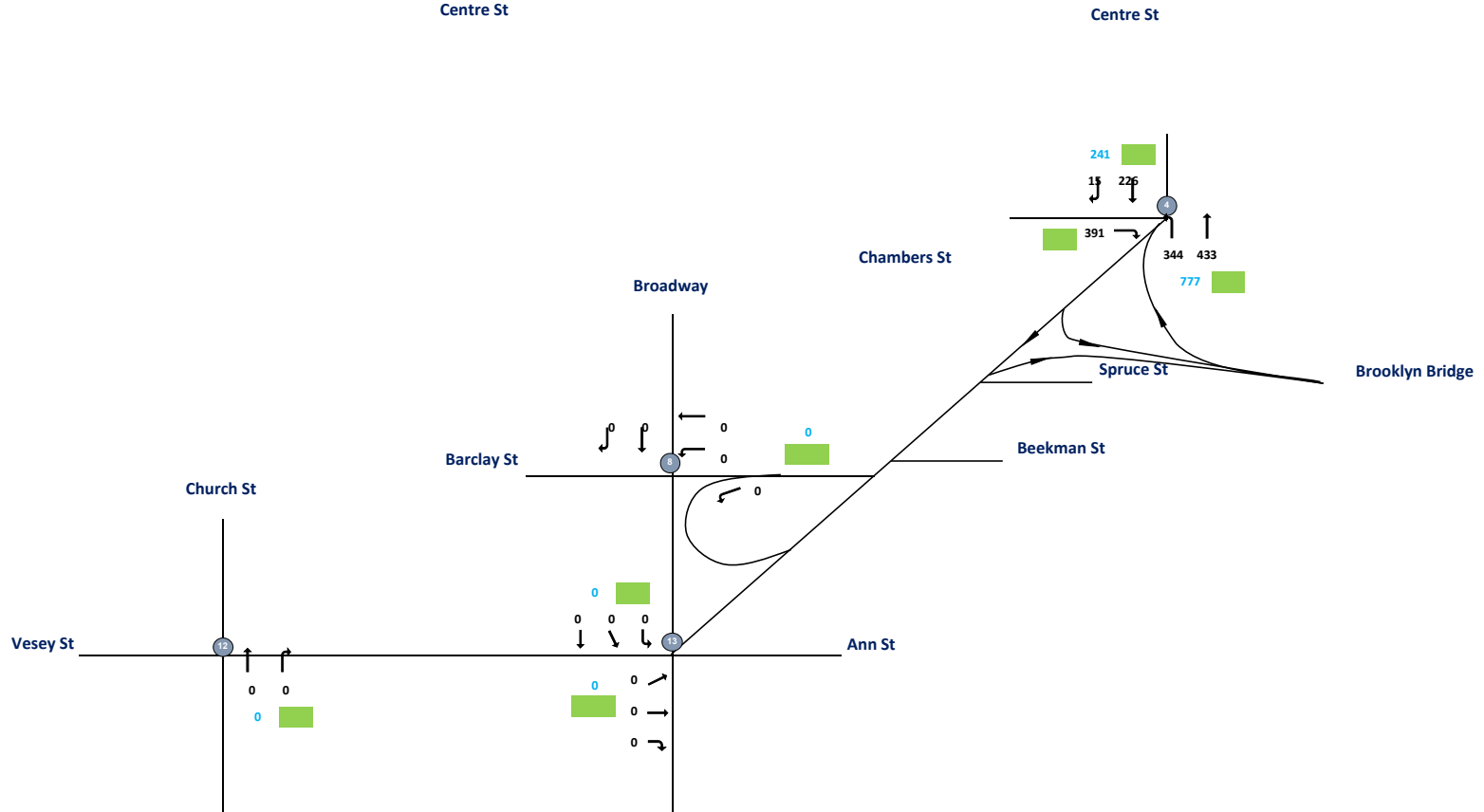
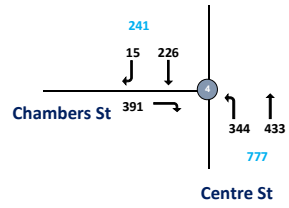

CBD Tolling
LM - Traffic Flowmap #3
MD No Action



- Legend:**
- Intersection (2019 Collected Data)
 - 7 - Intersection (Uncollected Data)
 - 100 - ATR Volume
 - 100 - Approach Volume

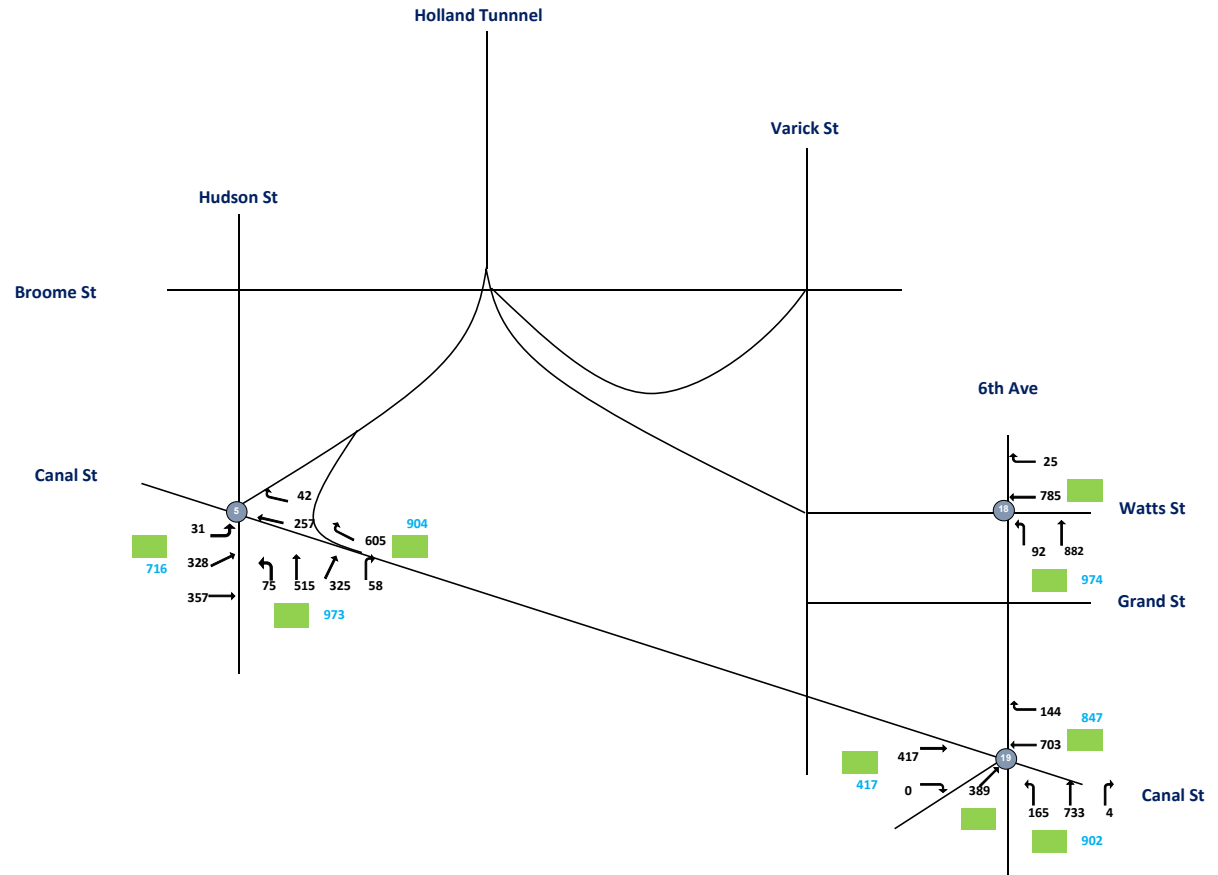

CBD Tolling
LM - Traffic Flowmap #4
MD No Action



- Legend:**
- Intersection (2019 Collected Data)
 - Intersection (Uncollected Data)
 - 100 - ATR Volume
 - 100 - Approach Volume

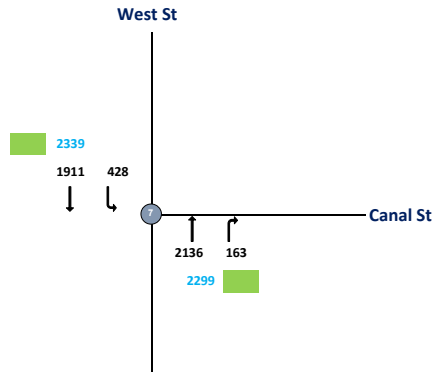

CBD Tolling
LM - Traffic Flowmap #5
MD No Action



- Legend:**
- Intersection (2019 Collected Data)
 - Intersection (Uncollected Data)
 - ATR Volume
 - Approach Volume

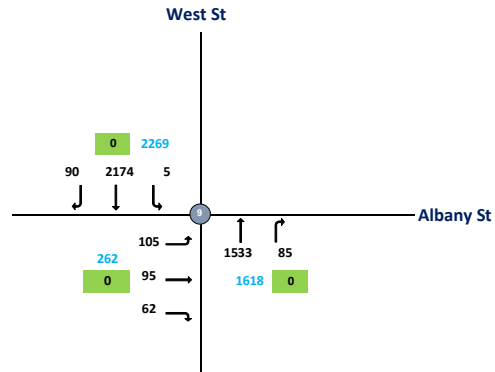

CBD Tolling
LM - Traffic Flowmap #6
MD No Action



- Legend:**
- 1 - Intersection (2019 Collected Data)
 - 7 - Intersection (Uncollected Data)
 - 100 - ATR Volume
 - 100 - Approach Volume
 - ↯ - Illegal movement

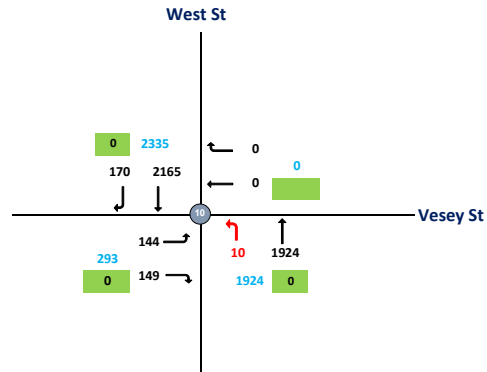

CBD Tolling
LM - Traffic Flowmap #7
MD No Action



- Legend:**
- 1 - Intersection (2019 Collected Data)
 - 7 - Intersection (Uncollected Data)
 - 100 - ATR Volume
 - 100 - Approach Volume

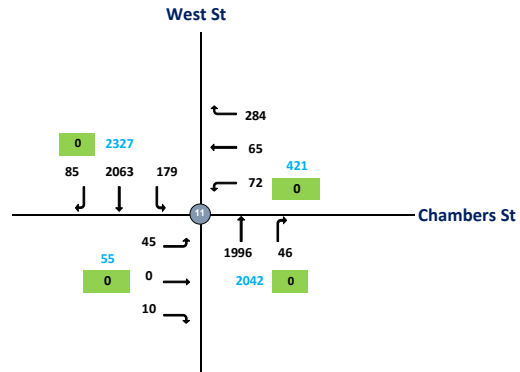

CBD Tolling
LM - Traffic Flowmap #8
MD No Action



- Legend:**
- Intersection (2019 Collected Data)
 - Intersection (Uncollected Data)
 - ATR Volume
 - Approach Volume

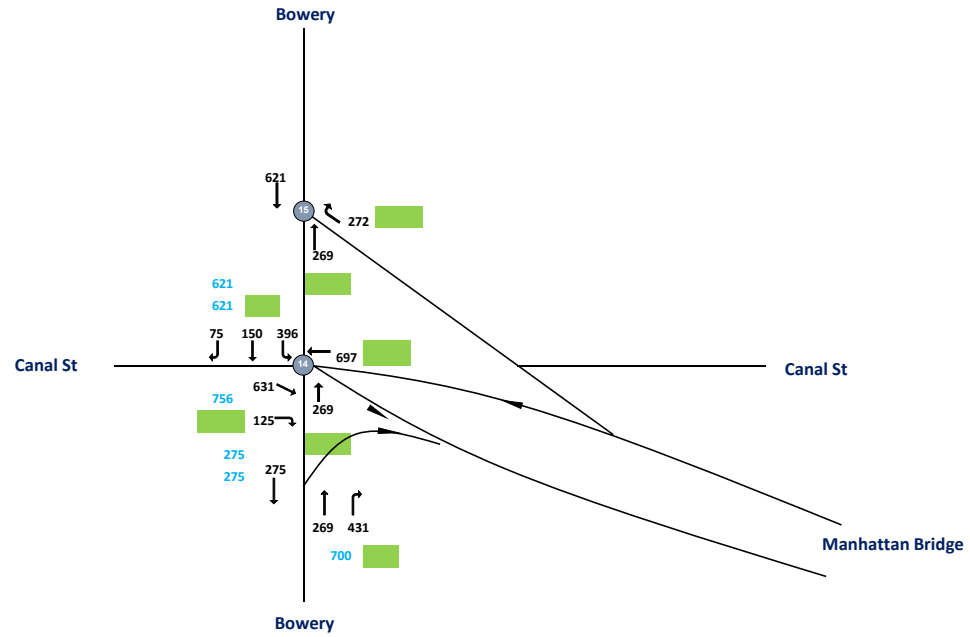

Intersection	Node	Approach	Total Vehicles					
			Inbound/Outbound					
			MD Peak Hour					
			L2	L	T	R	R2	Total
Edgar St. and Trinity Pl. 2019 (TMC-010)	1							
Edgar St.	1	EB	0	254	0	0	0	
478 Exit Ramp.	1	NE	0	0	0	0	0	
Trinity Pl.	1	NB	0	11	99	0	0	
Trinity Pl.	1	SB	0	0	0	0	0	364
Rector St. and Trinity Pl. 2019 (TMC-011)	2							
Rector St.	2	EB	0	110	45	0	0	
Rector St.	2	WB	0	0	0	0	0	
Trinity Pl.	2	NB	0	0	297	56	0	
Trinity Pl.	2	SB	0	0	0	0	0	508
West St. and HCT Exit. 2019 (TMC-012)	3							
-	3	EB	0	0	0	0	0	
HCT Exit.	3	WB	0	832	0	0	0	
West St.	3	NB	0	0	1033	0	781	
West St.	3	SB	0	0	1409	0	0	4055
West St. and HCT Exit. 2019 (TMC-012)	333							
W. Thams St.	333	EB	0	0	0	0	0	
HCT Exit.	333	WB	0	0	0	823	0	
West St.	333	NB	0	0	1033	0	0	
West St.	333	SB	0	0	1409	0	0	3265
Chambers St. and Centre St. 2018	4							
Chambers St.	4	EB	0	0	0	391	0	
-	4	WB	0	0	0	0	0	
Centre St.	4	NB	0	344	433	0	0	
Centre St.	4	SB	0	0	226	15	0	1409
Hudson St. and Canal St. 2018	5							
Canal St.	5	EB	31	328	357	0	0	
Canal St.	5	WB	0	0	257	42	0	
Hudson St.	5	NB	0	75	515	325	58	
Hudson St.	5	SB	0	0	0	0	0	1988

Hudson St. and Canal St.								
2018	555							
Canal St.	555	EB	0	0	415	0	0	
Canal St.	555	WB	0	0	299	605	0	
Hudson St.	555	NB	0	0	0	0	0	
Hudson St.	555	SB	0	0	0	0	0	1319
West St. and Canal St N.								
2018	7							
Canal St N.	7	EB	0	0	0	0	0	
-	7	WB	0	0	0	0	0	
West St.	7	NB	0	0	2136	163	0	
West St.	7	SB	0	428	1911	0	0	4638
West St. and Canal St S.								
2018	777							
-	777	EB	0	0	0	0	0	
Canal St S.	777	WB	0	0	0	0	0	
West St.	777	NB	0	0	2136	0	0	
West St.	777	SB	0	0	2339	0	0	4475
West St. and Albany St.								
2019 (TMC-013)	9							
Albany St.	9	EB	0	105	95	62	0	
-	9	WB	0	0	0	0	0	
West St.	9	NB	0	0	1533	85	0	
West St.	9	SB	0	5	2174	90	0	4149
West St. and Vesey St.								
2019 (TMC-014)	10							
Vesey St.	10	EB	0	144	0	149	0	
Vesey St.	10	WB	0	0	0	0	0	
West St.	10	NB	0	10	1924	0	0	
West St.	10	SB	0	0	2165	170	0	364
West St. and Chambers St.								
2019 (TMC-015)	11							
Chambers St.	11	EB	0	45	0	10	0	
Chambers St.	11	WB	0	72	65	284	0	
West St.	11	NB	0	0	1996	46	0	
West St.	11	SB	0	179	2063	85	0	4845

Bowey and Canal St./Manhattan Bridge Off-Ramp								
2018	14							
Canal St.	14	EB	0	0	631	125	0	
Manhattan Bridge Off-Ramp	14	WB	0	0	697	0	0	
Bowey	14	NB	0	0	269	431	0	
Bowey	14	SB	0	396	150	75	0	2774
Bowey and Manhattan Bridge Off-Ramp								
2018	15							
	15	EB	0	0	0	0	0	
Manhattan Bridge Off-Ramp	15	WB	0	0	0	272	0	
Bowey	15	NB	0	0	269	0	0	
Bowey	15	SB	0	0	621	0	0	1162
6th Ave. and Watts St								
2018	18							
Watts St	18	EB	0	0	0	0	0	
Watts St	18	WB	0	0	785	25	0	
6th Ave.	18	NB	0	92	882	0	0	
6th Ave.	18	SB	0	0	0	0	0	1784
6th Ave. and Canal St.								
2018	19							
Canal St.	19	EB	0	0	417	0	0	
Canal St.	19	WB	0	0	703	144	0	
6th Ave.	19	NB	0	165	733	4	0	
Laight St.	19	NE	0	0	0	389	0	2555

CBD Tolling
LM - Traffic Flowmap #1
PM No-Action



- Legend:**
- 1 - Intersection (2019 Collected Data)
 - 7 - Intersection (Uncollected Data)
 - 100 - ATR Volume
 - 100 - Approach Volume

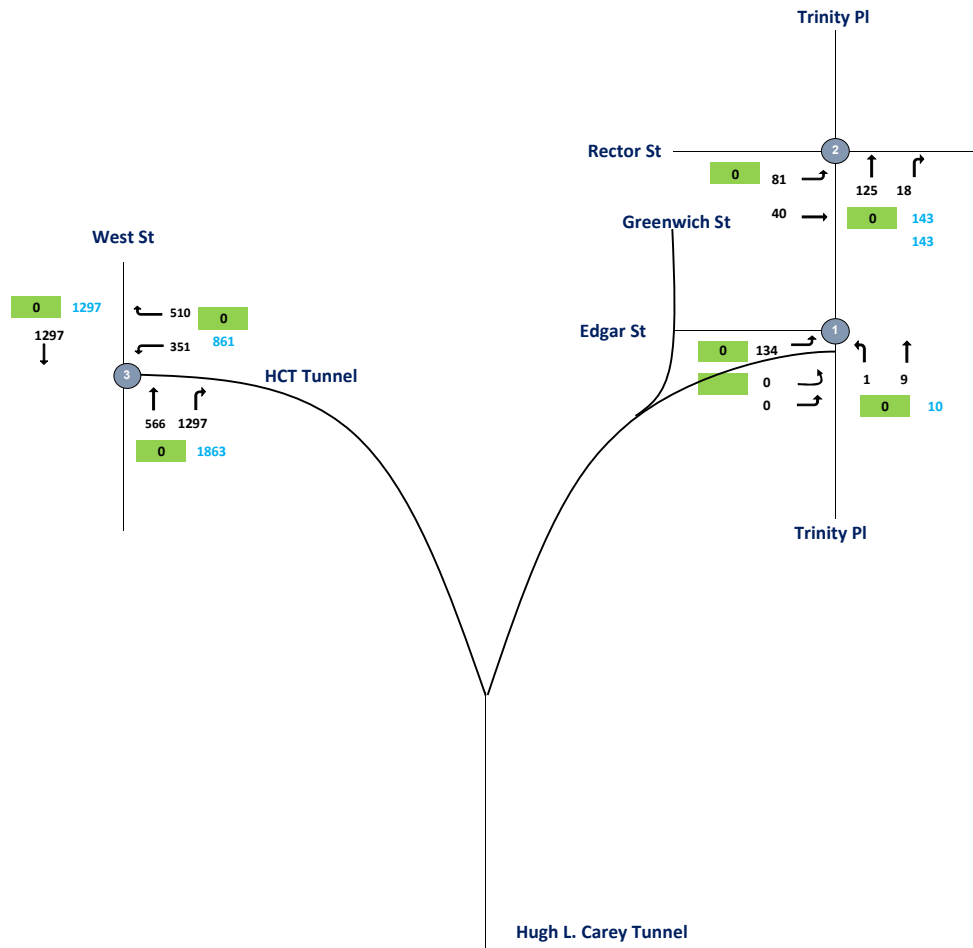

CBD Tolling
LM - Traffic Flowmap #2
PM No-Action



- Legend:**
- 1 - Intersection (2019 Collected Data)
 - 7 - Intersection (Uncollected Data)
 - 100 - ATR Volume
 - 100 - Approach Volume

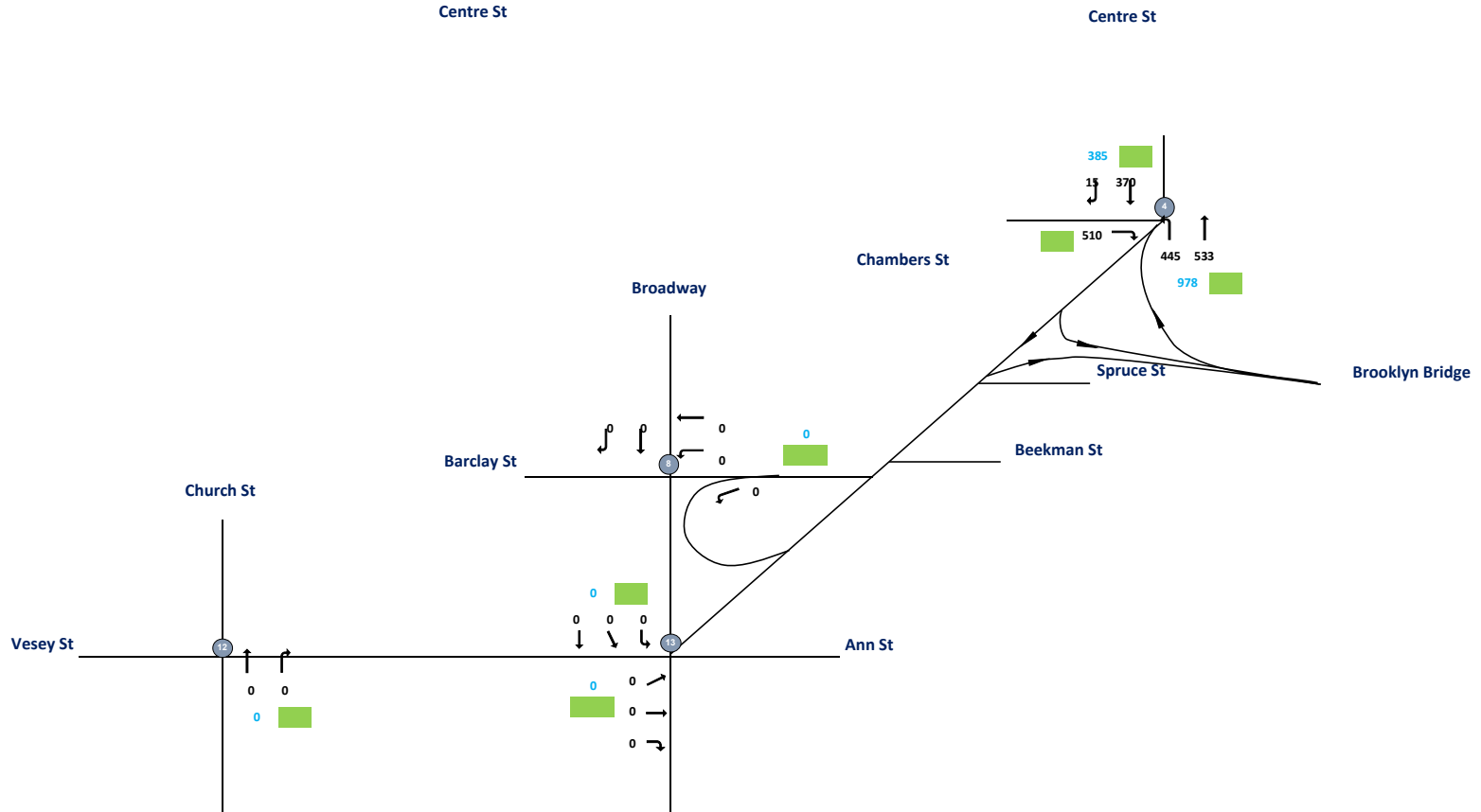
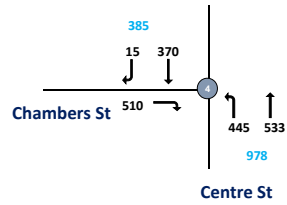

CBD Tolling
LM - Traffic Flowmap #3
PM No-Action



- Legend:**
- Intersection (2019 Collected Data)
 - Intersection (Uncollected Data)
 - 100 - ATR Volume
 - 100 - Approach Volume

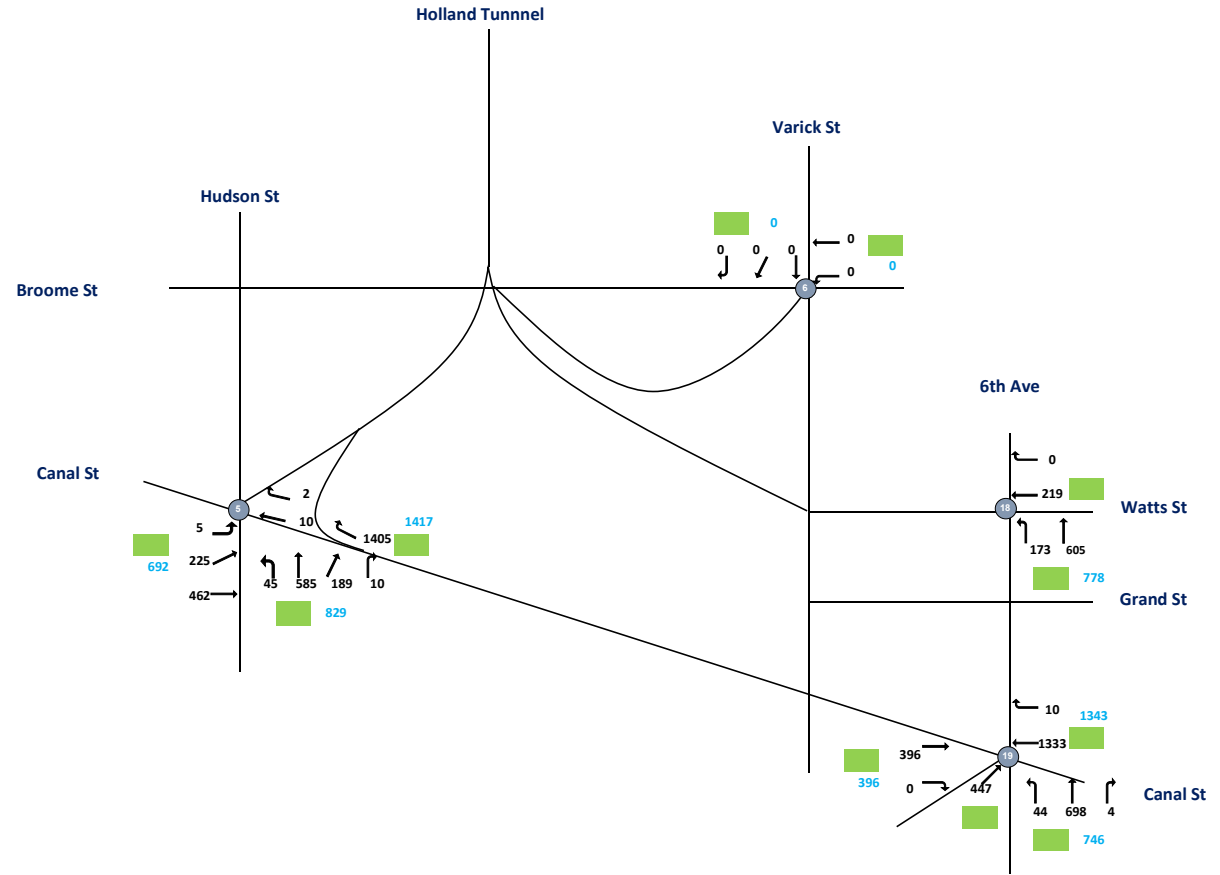

CBD Tolling
LM - Traffic Flowmap #4
PM No-Action



- Legend:
- 1 - Intersection (2019 Collected Data)
 - 7 - Intersection (Uncollected Data)
 - 100 - ATR Volume
 - 100 - Approach Volume

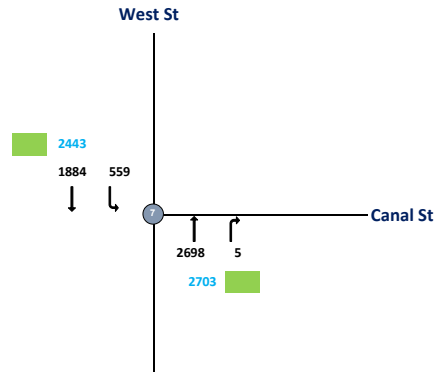

CBD Tolling
LM - Traffic Flowmap #5
PM No-Action



- Legend:**
- 1 - Intersection (2019 Collected Data)
 - 7 - Intersection (Uncollected Data)
 - 100 - ATR Volume
 - 100 - Approach Volume

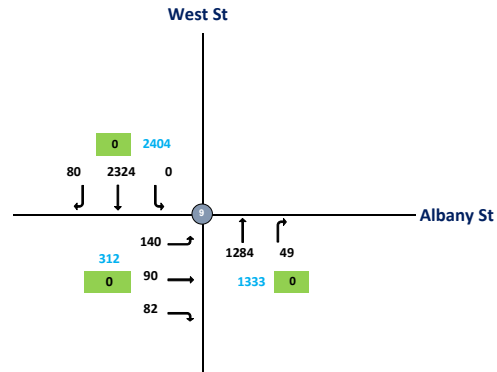

CBD Tolling
LM - Traffic Flowmap #6
PM No-Action



- Legend:**
- 1 - Intersection (2019 Collected Data)
 - 7 - Intersection (Uncollected Data)
 - 100 - ATR Volume
 - 100 - Approach Volume
 - ↯ - Illegal movement

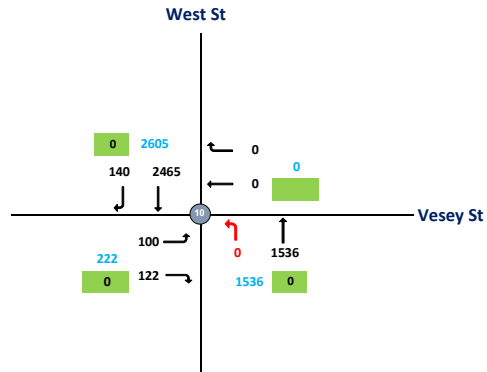

CBD Tolling
LM - Traffic Flowmap #7
PM No-Action



- Legend:**
- 1 - Intersection (2019 Collected Data)
 - 7 - Intersection (Uncollected Data)
 - 100 - ATR Volume
 - 100 - Approach Volume

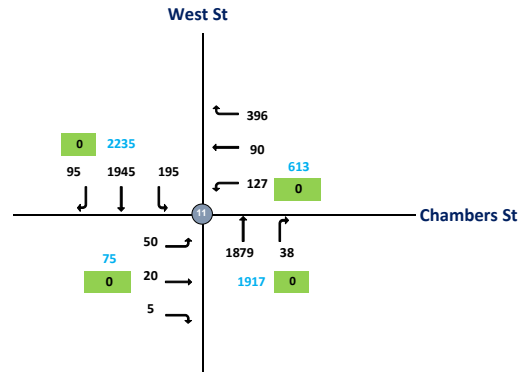

CBD Tolling
LM - Traffic Flowmap #8
PM No-Action



- Legend:**
- Intersection (2019 Collected Data)
 - Intersection (Uncollected Data)
 - 100 - ATR Volume
 - 100 - Approach Volume

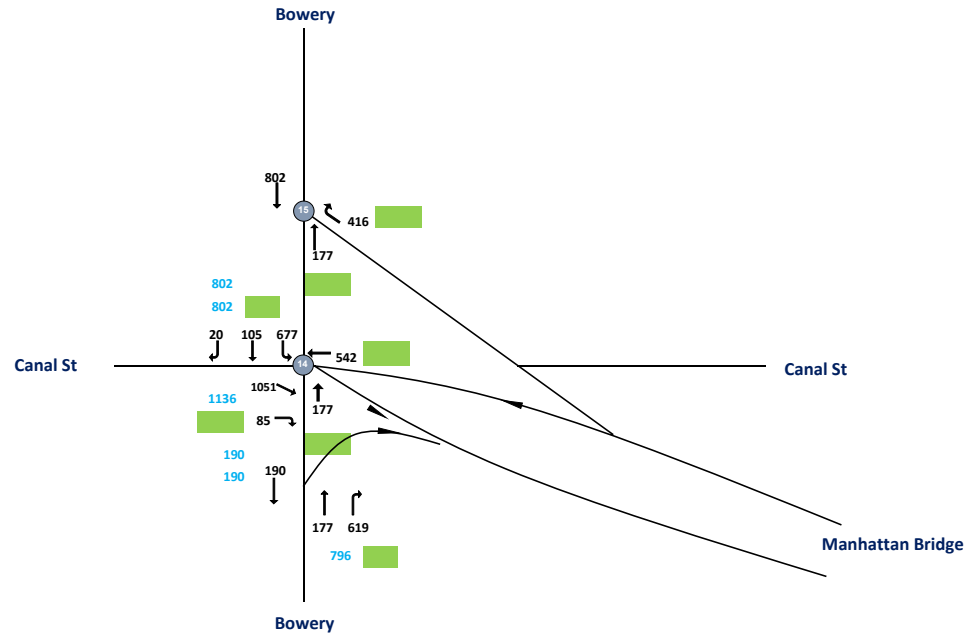

Intersection	Node	Approach	Total Vehicles					
			Inbound/Outbound					Total
			L2	L	T	R	R2	
Edgar St. and Trinity Pl. 2019 (TMC-010)	1							
Edgar St.	1	EB	0	134	0	0	0	
478 Exit Ramp.	1	NE	0	0	0	0	0	
Trinity Pl.	1	NB	0	1	9	0	0	
Trinity Pl.	1	SB	0	0	0	0	0	144
Rector St. and Trinity Pl. 2019 (TMC-011)	2							
Rector St.	2	EB	0	81	40	0	0	
Rector St.	2	WB	0	0	0	0	0	
Trinity Pl.	2	NB	0	0	125	18	0	
Trinity Pl.	2	SB	0	0	0	0	0	264
West St. and HCT Exit. 2019 (TMC-012)	3							
-	3	EB	0	0	0	0	0	
HCT Exit.	3	WB	0	351	0	0	0	
West St.	3	NB	0	0	566	0	1297	
West St.	3	SB	0	0	1297	0	0	3511
West St. and HCT Exit. 2019 (TMC-012)	333							
W. Thams St.	333	EB	0	0	0	0	0	
HCT Exit.	333	WB	0	0	0	510	0	
West St.	333	NB	0	0	566	0	0	
West St.	333	SB	0	0	1297	0	0	2373
Chambers St. and Centre St. 2018	4							
Chambers St.	4	EB	0	0	0	510	0	
-	4	WB	0	0	0	0	0	
Centre St.	4	NB	0	445	533	0	0	
Centre St.	4	SB	0	0	370	15	0	1873
Hudson St. and Canal St. 2018	5							
Canal St.	5	EB	5	225	462	0	0	
Canal St.	5	WB	0	0	10	2	0	
Hudson St.	5	NB	0	45	585	189	10	
Hudson St.	5	SB	0	0	0	0	0	1533

Hudson St. and Canal St.								
2018	555							
Canal St.	555	EB	0	0	472	0	0	
Canal St.	555	WB	0	0	12	1405	0	
Hudson St.	555	NB	0	0	0	0	0	
Hudson St.	555	SB	0	0	0	0	0	1889
West St. and Canal St N.								
2018	7							
Canal St N.	7	EB	0	0	0	0	0	
-	7	WB	0	0	0	0	0	
West St.	7	NB	0	0	2698	5	0	
West St.	7	SB	0	559	1884	0	0	5146
West St. and Canal St S.								
2018	777							
-	777	EB	0	0	0	0	0	
Canal St S.	777	WB	0	0	0	0	0	
West St.	777	NB	0	0	2698	0	0	
West St.	777	SB	0	0	2443	0	0	5141
West St. and Albany St.								
2019 (TMC-013)	9							
Albany St.	9	EB	0	140	90	82	0	
-	9	WB	0	0	0	0	0	
West St.	9	NB	0	0	1284	49	0	
West St.	9	SB	0	0	2324	80	0	4049
West St. and Vesey St.								
2019 (TMC-014)	10							
Vesey St.	10	EB	0	100	0	122	0	
Vesey St.	10	WB	0	10	0	0	0	
West St.	10	NB	0	0	1536	0	0	
West St.	10	SB	0	0	2465	140	0	144
West St. and Chambers St.								
2019 (TMC-015)	11							
Chambers St.	11	EB	0	50	20	5	0	
Chambers St.	11	WB	0	127	90	396	0	
West St.	11	NB	0	0	1879	38	0	
West St.	11	SB	0	195	1945	95	0	4840

Bowey and Canal St./Manhattan Bridge Off-Ramp								
2018	14							
Canal St.	14	EB	0	0	1051	85	0	
Manhattan Bridge Off-Ramp	14	WB	0	0	542	0	0	
Bowey	14	NB	0	0	177	619	0	
Bowey	14	SB	0	677	105	20	0	3276
Bowey and Manhattan Bridge Off-Ramp								
2018	15							
	15	EB	0	0	0	0	0	
Manhattan Bridge Off-Ramp	15	WB	0	0	0	416	0	
Bowey	15	NB	0	0	177	0	0	
Bowey	15	SB	0	0	802	0	0	1395
6th Ave. and Watts St								
2018	18							
Watts St	18	EB	0	0	0	0	0	
Watts St	18	WB	0	0	219	0	0	
6th Ave.	18	NB	0	173	605	0	0	
6th Ave.	18	SB	0	0	0	0	0	997
6th Ave. and Canal St.								
2018	19							
Canal St.	19	EB	0	0	396	0	0	
Canal St.	19	WB	0	0	1333	10	0	
6th Ave.	19	NB	0	44	698	4	0	
Laight St.	19	NE	0	0	0	447	0	2932

CBD Tolling
LT #1 - Traffic Flowmap
AM No Action



- Legend:**
- 1 - Intersection (2019 Collected Data)
 - 7 - Intersection (Pre-2019 Collected Data)
 - 100 - ATR Volume
 - 100 - Approach Volume

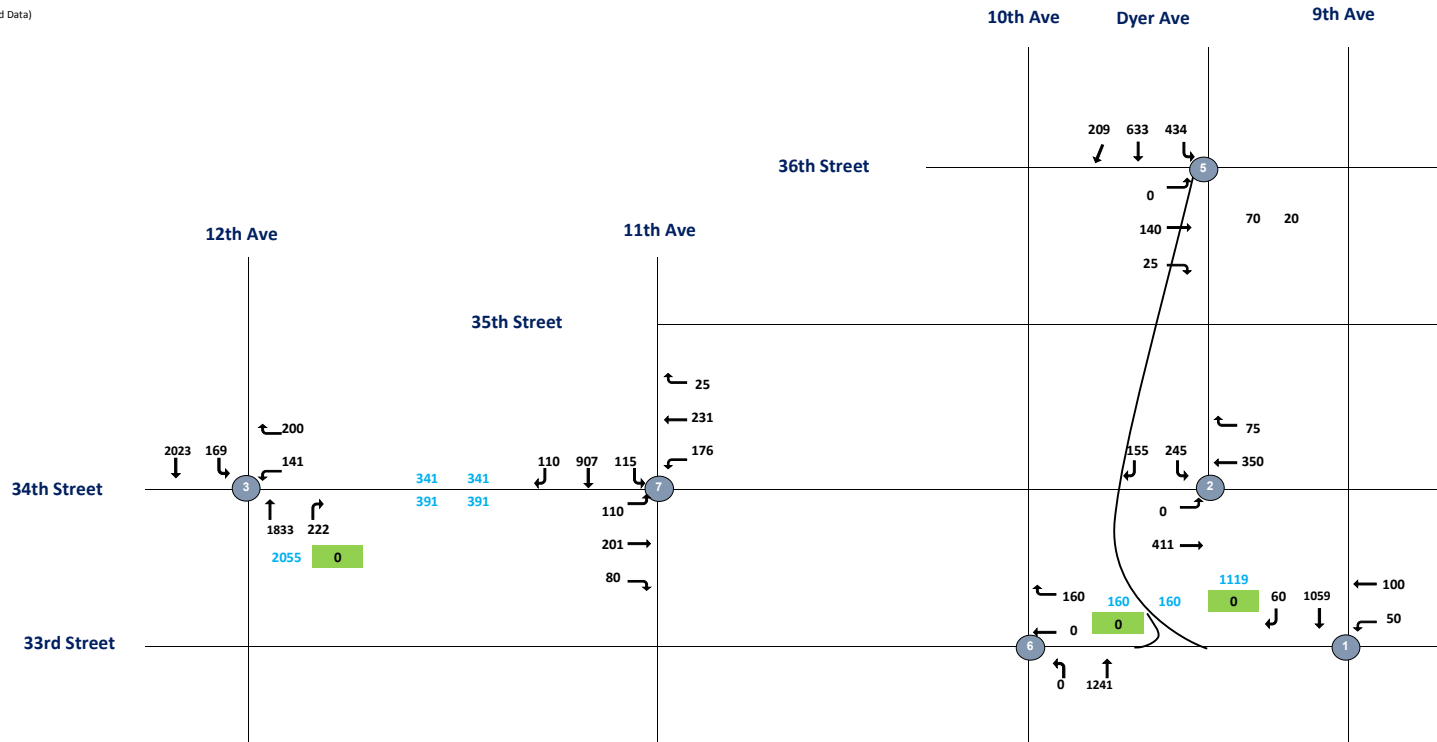

CBD Tolling
LT #2 - Traffic Flowmap
AM No Action



- Legend:**
- 1 - Intersection (2019 Collected Data)
 - 7 - Intersection (Pre-2019 Collected Data)
 - 100 - ATR Volume
 - 100 - Approach Volume

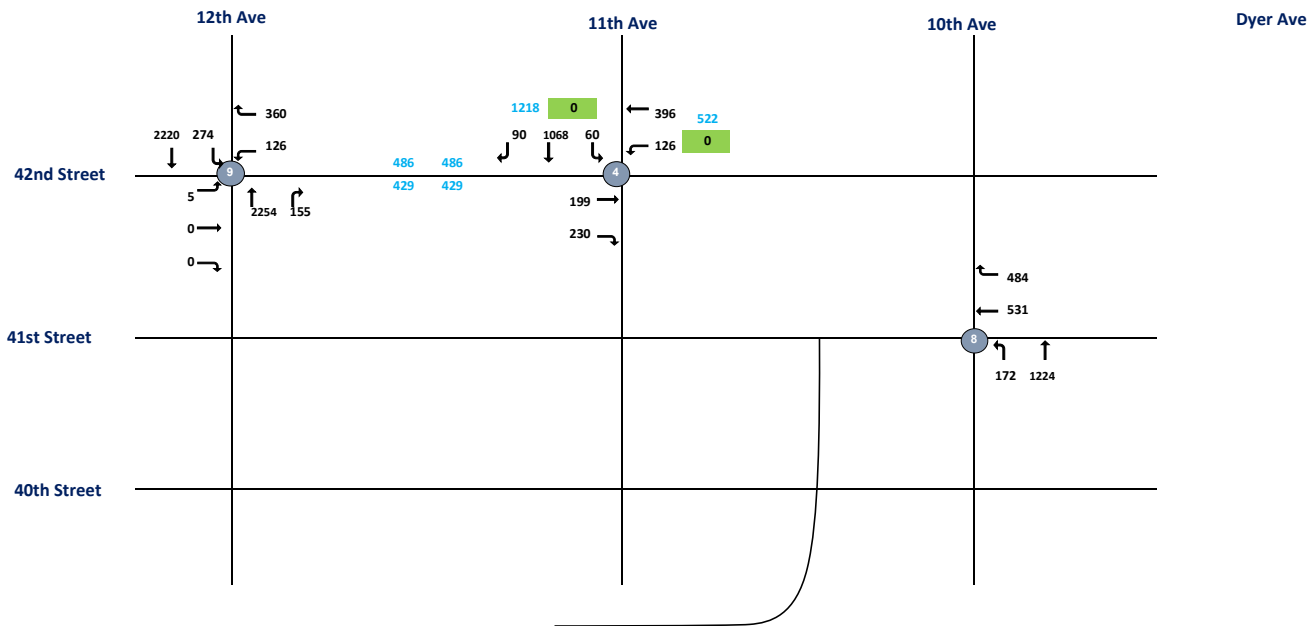

LT

8:00:00 AM

Intersection	Node	Approach	Total Vehicles					
			Inbound/Outbound					
			AM Peak Hour					
			L2	L	T	R	R2	Total
33rd Street and 9th Avenue 2019 (WRY-TMC-109)	1							
33rd Street	1	EB	0	0	0	0	0	
33rd Street	1	WB	0	50	100	0	0	
9th Avenue	1	NB	0	0	0	0	0	
9th Avenue	1	SB	0	0	1059	60	0	1269
34th Street and Dyer Avenue 2019 (WRY-TMC-105)	2							
34th Street	2	EB	0	0	411	0	0	
34th Street	2	WB	0	0	350	75	0	
Dyer Avenue	2	NB	0	0	0	0	0	
Dyer Avenue	2	SB	0	245	0	155	0	1236
34th Street and 12th Avenue 2019 (PABT-TMC-055)	3							
34th Street	3	EB	0	0	0	0	0	
34th Street	3	WB	0	141	0	200	0	
12th Avenue	3	NB	0	0	1833	222	0	
12th Avenue	3	SB	0	169	2023	0	0	4588
42nd Street and 11th Avenue 2019 (PABT-TMC-052)	4							
42nd Street	4	EB	0	0	199	230	0	
42nd Street	4	WB	0	126	396	0	0	
11th Avenue	4	NB	0	0	0	0	0	
11th Avenue	4	SB	0	60	1068	90	0	2169
36th Street and Dyer Avenue 2019 (PABT-TMC-060)	5							
36th Street	5	EB	0	0	140	25	0	
36th Street	5	WB	0	0	0	0	0	
Dyer Avenue	5	NB	0	0	70	20	0	
Dyer Avenue	5	SB	0	434	633	209	0	1531
33rd Street and 10th Avenue 2019 (WRY-TMC-108)	6							
33rd Street	6	EB	0	0	0	0	0	
33rd Street	6	WB	0	0	0	160	0	
10th Avenue	6	NB	0	0	1241	0	0	
10th Avenue	6	SB	0	0	0	0	0	1401

34th Street and 11th Avenue 2019 (PABT-TMC-044)	7								
34th Street	7	EB	0	110	201	80	0		
34th Street	7	WB	0	176	231	25	0		
11th Avenue	7	NB	0	0	0	0	0		
11th Avenue	7	SB	0	115	907	110	0		1955
34th Street and 11th Avenue 2019 (PABT-TMC-040)	8								
34th Street	8	EB	0	0	0	0	0		
34th Street	8	WB	0	0	531	484	0		
11th Avenue	8	NB	0	172	1224	0	0		
11th Avenue	8	SB	0	0	0	0	0		2411
42nd Street and 12th Avenue 2019 (PABT-TMC-057)	9								
42nd Street	9	EB	0	5	0	0	0		
42nd Street	9	WB	0	126	0	360	0		
12th Avenue	9	NB	0	0	2254	155	0		
12th Avenue	9	SB	0	274	2220	0	0		5394

CBD Tolling
LT #1 - Traffic Flowmap
MD With Action



- Legend:**
- 1 - Intersection (2019 Collected Data)
 - 7 - Intersection (Pre-2019 Collected Data)
 - 100 - ATR Volume
 - 100 - Approach Volume

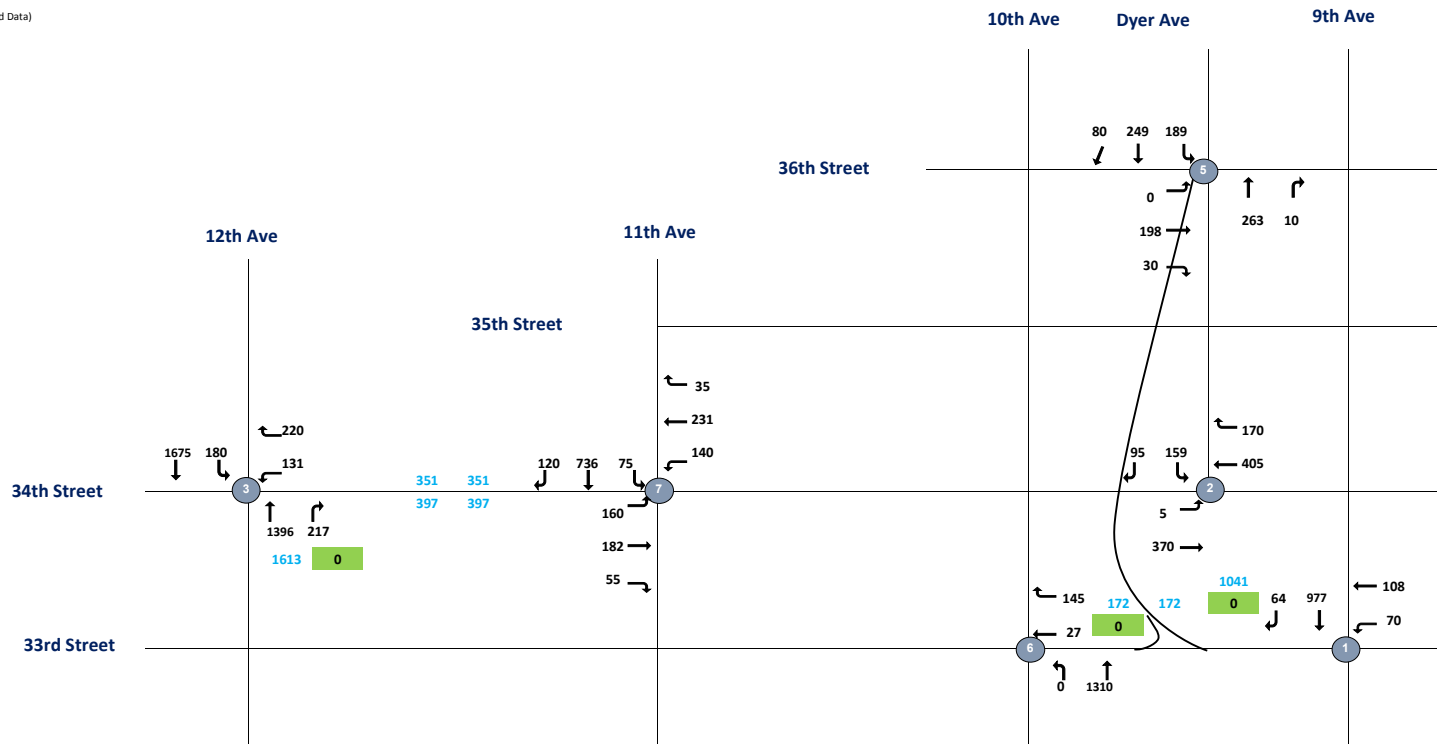

CBD Tolling
LT #2 - Traffic Flowmap
MD With Action



- Legend:**
- 1 - Intersection (2019 Collected Data)
 - 7 - Intersection (Pre-2019 Collected Data)
 - 100 - ATR Volume
 - 100 - Approach Volume

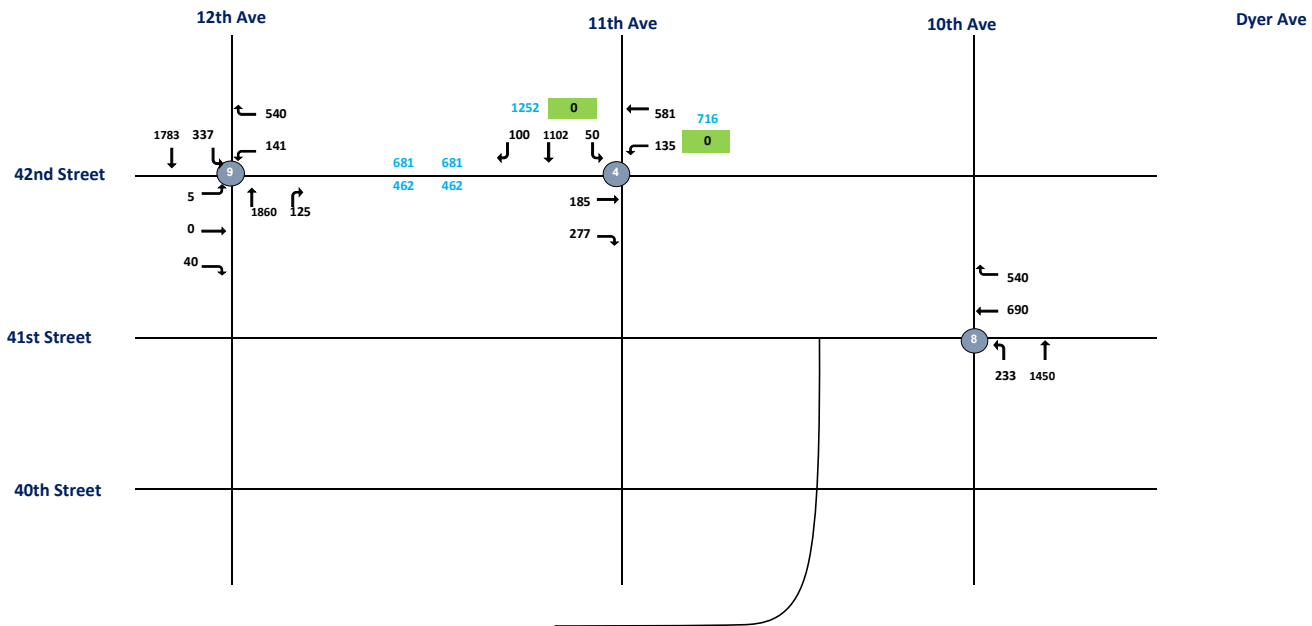

LT

12:00:00 PM

Intersection	Node	Approach	Total Vehicles					
			Inbound/Outbound					
			MD Peak Hour					
			L2	L	T	R	R2	Total
33rd Street and 9th Avenue 2019 (WRY-TMC-109)	1							
33rd Street	1	EB	0	0	0	0	0	
33rd Street	1	WB	0	70	92	0	0	
9th Avenue	1	NB	0	0	0	0	0	
9th Avenue	1	SB	0	0	920	51	0	1133
34th Street and Dyer Avenue 2019 (WRY-TMC-105)	2							
34th Street	2	EB	0	5	337	0	0	
34th Street	2	WB	0	0	409	172	0	
Dyer Avenue	2	NB	0	0	0	0	0	
Dyer Avenue	2	SB	0	143	0	90	0	1156
34th Street and 12th Avenue 2019 (PABT-TMC-055)	3							
34th Street	3	EB	0	0	0	0	0	
34th Street	3	WB	0	134	0	221	0	
12th Avenue	3	NB	0	0	1375	214	0	
12th Avenue	3	SB	0	165	1567	0	0	3676
42nd Street and 11th Avenue 2019 (PABT-TMC-052)	4							
42nd Street	4	EB	0	0	166	238	0	
42nd Street	4	WB	0	135	581	0	0	
11th Avenue	4	NB	0	0	0	0	0	
11th Avenue	4	SB	0	45	859	90	0	2114
36th Street and Dyer Avenue 2019 (PABT-TMC-060)	5							
36th Street	5	EB	0	0	178	30	0	
36th Street	5	WB	0	0	0	0	0	
Dyer Avenue	5	NB	0	0	228	10	0	
Dyer Avenue	5	SB	0	169	222	71	0	908
33rd Street and 10th Avenue 2019 (WRY-TMC-108)	6							
33rd Street	6	EB	0	0	0	0	0	
33rd Street	6	WB	0	0	12	131	0	
10th Avenue	6	NB	0	0	1260	0	0	
10th Avenue	6	SB	0	0	0	0	0	1403

34th Street and 11th Avenue 2019 (PABT-TMC-044)	7								
34th Street	7	EB	0	152	173	54	0		
34th Street	7	WB	0	142	234	34	0		
11th Avenue	7	NB	0	0	0	0	0		
11th Avenue	7	SB	0	71	697	121	0		1678
34th Street and 11th Avenue 2019 (PABT-TMC-040)	8								
34th Street	8	EB	0	0	0	0	0		
34th Street	8	WB	0	0	472	533	0		
11th Avenue	8	NB	0	157	1419	0	0		
11th Avenue	8	SB	0	0	0	0	0		2581
42nd Street and 12th Avenue 2019 (PABT-TMC-057)	9								
42nd Street	9	EB	0	5	0	40	0		
42nd Street	9	WB	0	138	0	533	0		
12th Avenue	9	NB	0	0	1861	117	0		
12th Avenue	9	SB	0	287	1669	0	0		4650

CBD Tolling
LT #1 - Traffic Flowmap
PM With Action



- Legend:**
- ① - Intersection (2019 Collected Data)
 - ⑦ - Intersection (Pre-2019 Collected Data)
 - 100 - ATR Volume
 - 100 - Approach Volume

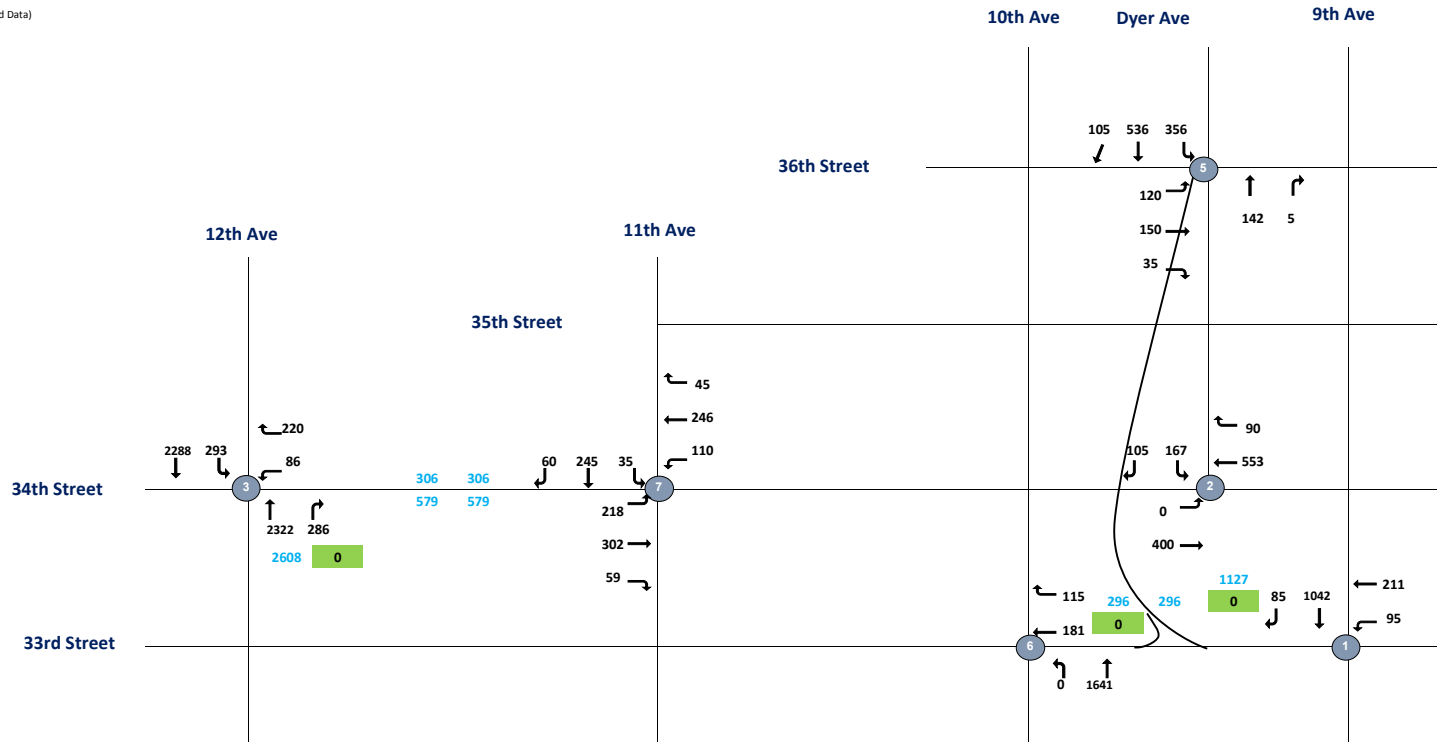

CBD Tolling
LT #2 - Traffic Flowmap
PM With Action



- Legend:**
- ① - Intersection (2019 Collected Data)
 - ② - Intersection (Pre-2019 Collected Data)
 - 100 - ATR Volume
 - 100 - Approach Volume

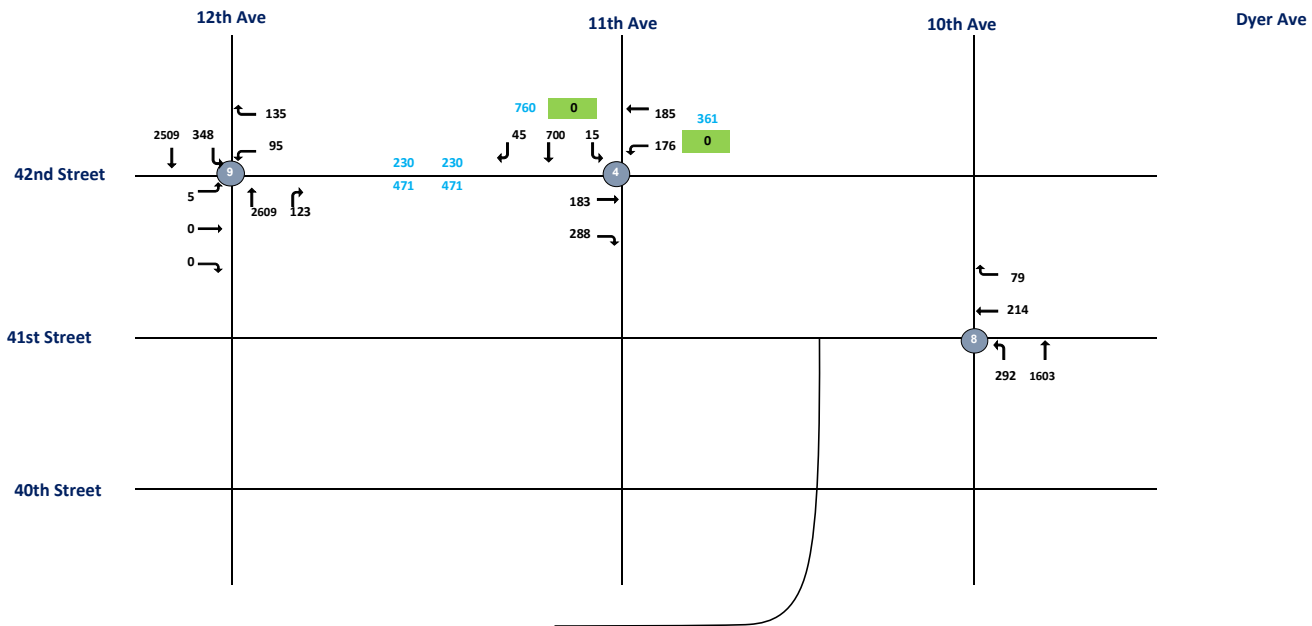

LT

5:00:00 PM

Intersection	Node	Approach	Total Vehicles					
			Inbound/Outbound					
			PM Peak Hour					
			L2	L	T	R	R2	Total
33rd Street and 9th Avenue 2019 (WRY-TMC-109)	1							
33rd Street	1	EB	0	0	0	0	0	
33rd Street	1	WB	0	95	195	0	0	
9th Avenue	1	NB	0	0	0	0	0	
9th Avenue	1	SB	0	0	962	72	0	1324
34th Street and Dyer Avenue 2019 (WRY-TMC-105)	2							
34th Street	2	EB	0	0	368	0	0	
34th Street	2	WB	0	0	546	89	0	
Dyer Avenue	2	NB	0	0	0	0	0	
Dyer Avenue	2	SB	0	158	0	103	0	1264
34th Street and 12th Avenue 2019 (PABT-TMC-055)	3							
34th Street	3	EB	0	0	0	0	0	
34th Street	3	WB	0	81	0	215	0	
12th Avenue	3	NB	0	0	2250	277	0	
12th Avenue	3	SB	0	276	2105	0	0	5204
42nd Street and 11th Avenue 2019 (PABT-TMC-052)	4							
42nd Street	4	EB	0	0	177	256	0	
42nd Street	4	WB	0	177	185	0	0	
11th Avenue	4	NB	0	0	0	0	0	
11th Avenue	4	SB	0	12	527	37	0	1371
36th Street and Dyer Avenue 2019 (PABT-TMC-060)	5							
36th Street	5	EB	0	119	136	35	0	
36th Street	5	WB	0	0	0	0	0	
Dyer Avenue	5	NB	0	0	111	4	0	
Dyer Avenue	5	SB	0	344	518	102	0	1369
33rd Street and 10th Avenue 2019 (WRY-TMC-108)	6							
33rd Street	6	EB	0	0	0	0	0	
33rd Street	6	WB	0	0	153	114	0	
10th Avenue	6	NB	0	0	1581	0	0	
10th Avenue	6	SB	0	0	0	0	0	1848

34th Street and 11th Avenue 2019 (PABT-TMC-044)	7								
34th Street	7	EB	0	208	288	57	0		
34th Street	7	WB	0	110	245	44	0		
11th Avenue	7	NB	0	0	0	0	0		
11th Avenue	7	SB	0	30	208	51	0		1241
34th Street and 11th Avenue 2019 (PABT-TMC-040)	8								
34th Street	8	EB	0	0	0	0	0		
34th Street	8	WB	0	0	65	71	0		
11th Avenue	8	NB	0	111	1570	0	0		
11th Avenue	8	SB	0	0	0	0	0		1817
42nd Street and 12th Avenue 2019 (PABT-TMC-057)	9								
42nd Street	9	EB	0	5	0	0	0		
42nd Street	9	WB	0	91	0	131	0		
12th Avenue	9	NB	0	0	2559	116	0		
12th Avenue	9	SB	0	317	2308	0	0		5527

**New Jersey
2021 No Action
AM Peak Hour**

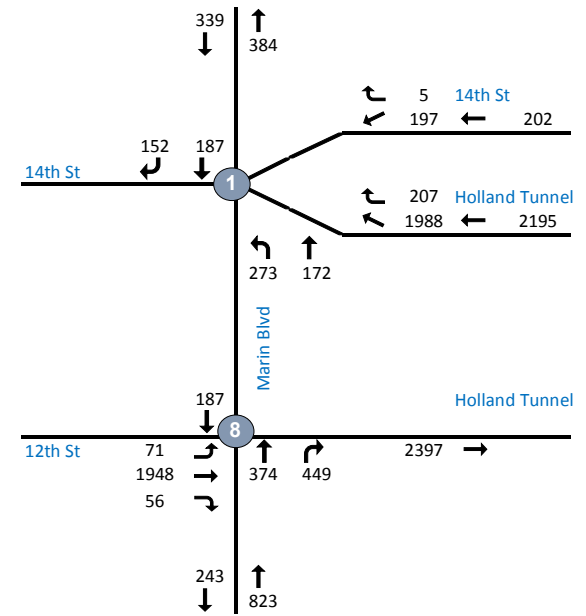
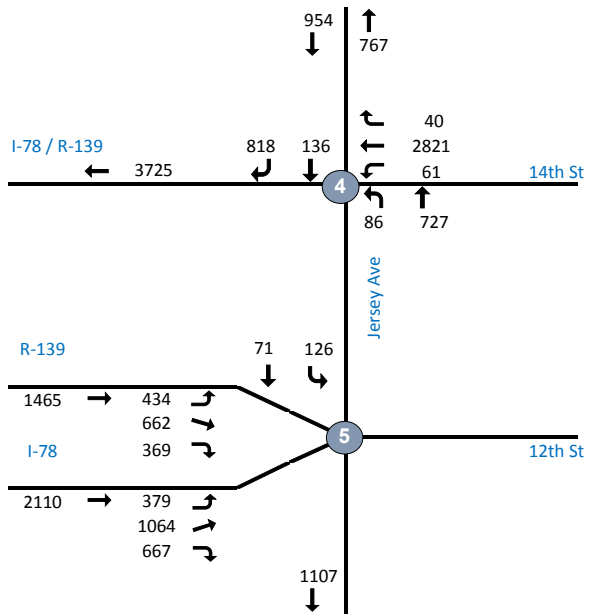

Intersection	Node	Approach	Total Vehicles					
			Inbound/Outbound					Total
			L2	L	T	R	R2	
14th Street (E-W) & Jersey Avenue (N-S)								
NJ-TMC-007.xlsx								
n/a	4	EB	0	0	0	0	0	
14th Street	4	WB	0	61	2821	40	0	
Jersey Avenue	4	NB	0	86	727	0	0	
Jersey Avenue	4	SB	0	0	136	818	0	4689
14th Street/Holland Tunnel (E-W) & Marin Boulevard (N-S)								
NJ-TMC-008.xlsx								
Holland Tunnel	1	WB	0	0	1988	207	0	
14th Street	1	SW	0	0	0	197	5	
Marin Boulevard	1	NB	0	273	172	0	0	
Marin Boulevard	1	SB	0	0	187	152	0	3181
12th Street (E-W) & Jersey Avenue (N-S)								
NJ-TMC-009.xlsx	5							
R-139	5	SE	434	662	0	369	0	
I-78	5	EB	0	379	1064	667	0	
Jersey Avenue	5	NB	0	0	0	0	0	
Jersey Avenue	5	SB	0	126	71	0	0	3772
12th Street (E-W) & Marin Blvd (N-S)								
NJ-TMC-010.xlsx	8							
12th Street/Holland Tunnel	8	EB	0	71	1948	56	0	
n/a	8	WB	0	0	0	0	0	
Marin Boulevard	8	NB	0	0	374	449	0	
Marin Boulevard	8	SB	0	0	187	0	0	3085

**New Jersey
2021 No Action
MD Peak Hour**

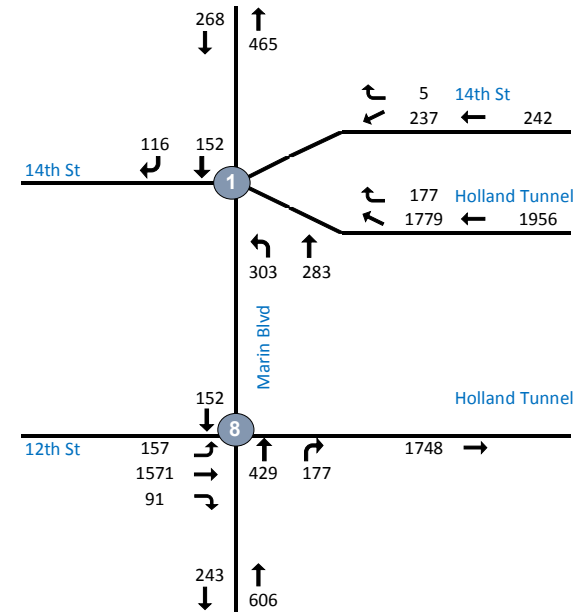
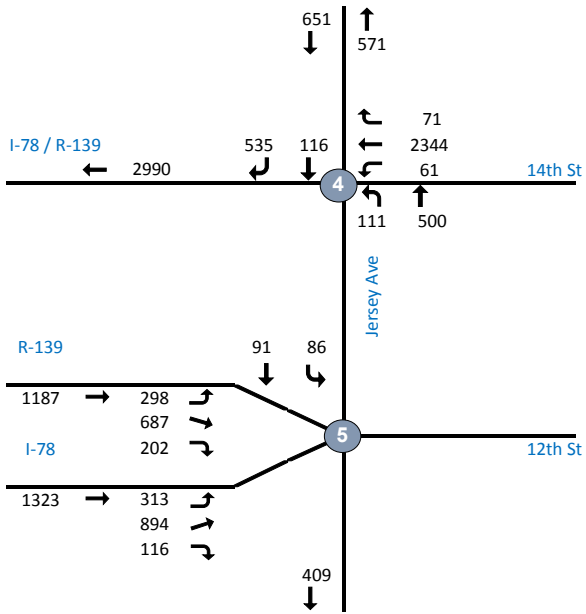

Intersection	Node	Approach	Total Vehicles					
			Inbound/Outbound					Total
			L2	L	T	R	R2	
14th Street (E-W) & Jersey Avenue (N-S)								
NJ-TMC-007.xlsx								
n/a	4	EB	0	0	0	0	0	
14th Street	4	WB	0	61	2344	71	0	
Jersey Avenue	4	NB	0	111	500	0	0	
Jersey Avenue	4	SB	0	0	116	535	0	
							3738	
14th Street/Holland Tunnel (E-W) & Marin Boulevard (N-S)								
NJ-TMC-008.xlsx								
Holland Tunnel	1	WB	0	0	1779	177	0	
14th Street	1	SW	0	0	0	237	5	
Marin Boulevard	1	NB	0	303	283	0	0	
Marin Boulevard	1	SB	0	0	152	116	0	
							3052	
12th Street (E-W) & Jersey Avenue (N-S)								
NJ-TMC-009.xlsx	5							
R-139	5	SE	298	687	0	202	0	
I-78	5	EB	0	313	894	116	0	
Jersey Avenue	5	NB	0	0	0	0	0	
Jersey Avenue	5	SB	0	86	91	0	0	
							2687	
12th Street (E-W) & Marin Blvd (N-S)								
NJ-TMC-010.xlsx	8							
12th Street/Holland Tunnel	8	EB	0	157	1571	91	0	
n/a	8	WB	0	0	0	0	0	
Marin Boulevard	8	NB	0	0	429	177	0	
Marin Boulevard	8	SB	0	0	152	0	0	
							2577	

**New Jersey
2021 No Action
PM Peak Hour**

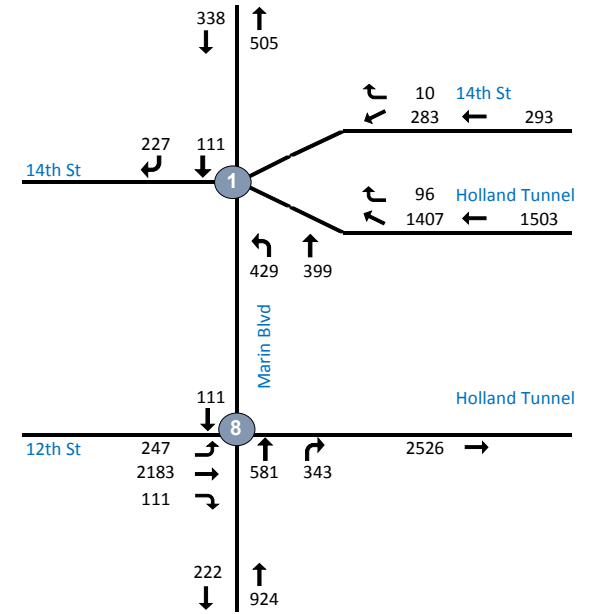
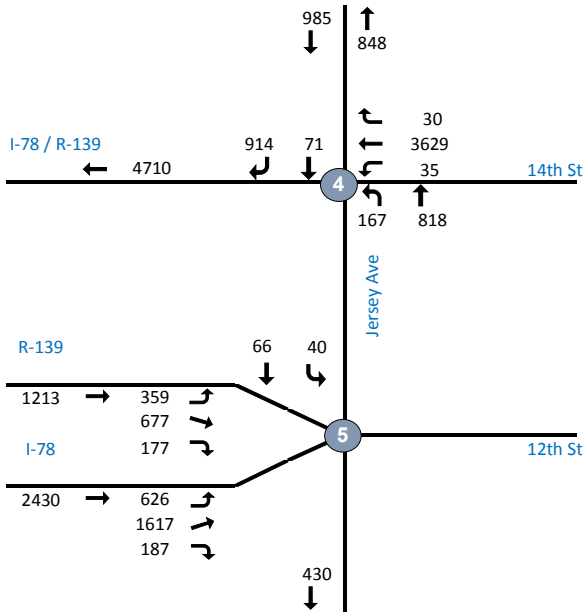

Intersection	Node	Approach	Total Vehicles					
			Inbound/Outbound					Total
			L2	L	T	R	R2	
14th Street (E-W) & Jersey Avenue (N-S)								
NJ-TMC-007.xlsx								
n/a	4	EB	0	0	0	0	0	
14th Street	4	WB	0	35	3629	30	0	
Jersey Avenue	4	NB	0	167	818	0	0	
Jersey Avenue	4	SB	0	0	71	914	0	5664
14th Street/Holland Tunnel (E-W) & Marin Boulevard (N-S)								
NJ-TMC-008.xlsx								
Holland Tunnel	1	WB	0	0	1407	96	0	
14th Street	1	SW	0	0	0	283	10	
Marin Boulevard	1	NB	0	429	399	0	0	
Marin Boulevard	1	SB	0	0	111	227	0	2962
12th Street (E-W) & Jersey Avenue (N-S)								
NJ-TMC-009.xlsx	5							
R-139	5	SE	359	677	0	177	0	
I-78	5	EB	0	626	1617	187	0	
Jersey Avenue	5	NB	0	0	0	0	0	
Jersey Avenue	5	SB	0	40	66	0	0	3749
12th Street (E-W) & Marin Blvd (N-S)								
NJ-TMC-010.xlsx	8							
12th Street/Holland Tunnel	8	EB	0	247	2183	111	0	
n/a	8	WB	0	0	0	0	0	
Marin Boulevard	8	NB	0	0	581	343	0	
Marin Boulevard	8	SB	0	0	111	0	0	3576

CBD Tolling
QMT - Traffic Flowmap
AM No-Action



- Legend:**
- 1 - Intersection (2019 Collected Data)
 - 7 - Intersection (Uncollected Data)
 - 100 - ATR Volume
 - 100 - Approach Volume

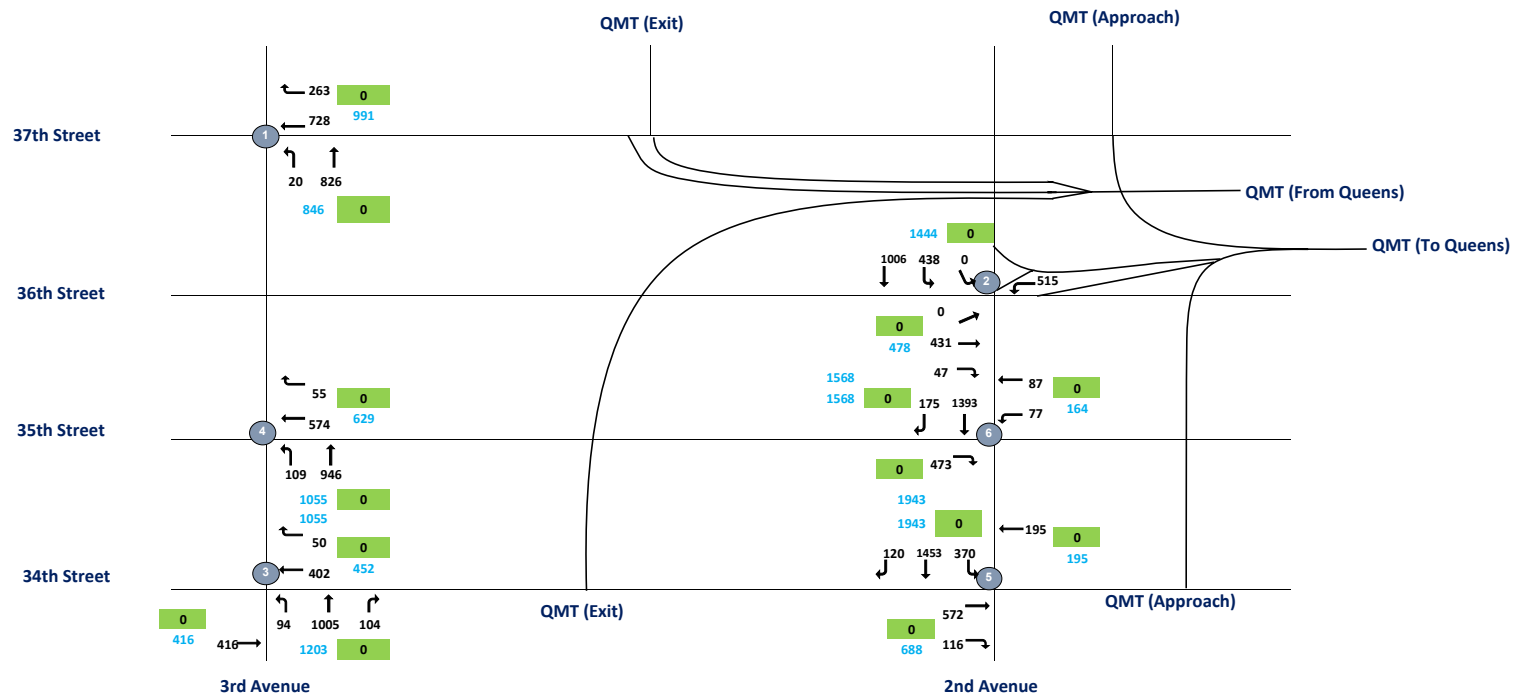

QM

8:00:00 AM

Intersection	Node	Approach	Total Vehicles					
			Inbound/Outbound					Total
			AM Peak Hour					
L2	L	T	R	R2				
37th St & 3rd Ave 2019 (TMC-016)	1							
37th St	1	EB	0	0	0	0	0	
37th St	1	WB	0	0	728	263	0	
3rd Ave	1	NB	0	20	826	0	0	
3rd Ave	1	SB	0	0	0	0	0	1837
36th St & 2nd Ave 2019 (TMC-017)	2							
36th St	2	EB	0	0	431	47	0	
36th St	2	WB	0	515	0	0	0	
2nd Ave	2	NB	0	0	0	0	0	
2nd Ave	2	SB	0	438	1006	0	0	2437
34th St & 3rd Ave 2019 (TMC-018)	3							
34th St	3	EB	0	0	416	0	0	
34th St	3	WB	0	0	402	50	0	
3rd Ave	3	NB	0	94	1005	104	0	
	3	SB	0	0	0	0	0	2071
35th St & 3rd Ave 2019 (TMC-019)	4							
35th St	4	EB	0	0	0	0	0	
35th St	4	WB	0	0	574	55	0	
3rd Ave	4	NB	0	109	946	0	0	
	4	SB	0	0	0	0	0	1684
34th St & 2nd Ave 2019 (TMC-020)	5							
34th St	5	EB	0	0	572	116	0	
34th St	5	WB	0	0	195	0	0	
2nd Ave	5	NB	0	0	0	0	0	
2nd Ave	5	SB	0	370	1453	120	0	2826
35th St & 2nd Ave 2019 (TMC-021)	6							
35th St	6	EB	0	0	0	473	0	
35th St	6	WB	0	77	87	0	0	
2nd Ave	6	NB	0	0	0	0	0	
2nd Ave	6	SB	0	0	1393	175	0	2205

QM

1:00:00 PM

Intersection	Node	Approach	Total Vehicles					
			Inbound/Outbound					
			MD Peak Hour					
			L2	L	T	R	R2	Total
37th St & 3rd Ave 2019 (TMC-016)	1							
37th St	1	EB	0	0	0	0	0	
37th St	1	WB	0	0	577	265	0	
3rd Ave	1	NB	0	44	635	0	0	
3rd Ave	1	SB	0	0	0	0	0	1521
36th St & 2nd Ave 2019 (TMC-017)	2							
36th St	2	EB	0	0	1278	85	0	
36th St	2	WB	0	0	0	0	0	
2nd Ave	2	NB	0	0	0	0	0	
2nd Ave	2	SB	0	242	1035	0	0	2640
34th St & 3rd Ave 2019 (TMC-018)	3							
34th St	3	EB	0	0	445	0	0	
34th St	3	WB	0	0	450	80	0	
3rd Ave	3	NB	0	24	1075	173	0	
	3	SB	0	0	0	0	0	2247
35th St & 3rd Ave 2019 (TMC-019)	4							
35th St	4	EB	0	0	0	0	0	
35th St	4	WB	0	0	519	60	0	
3rd Ave	4	NB	0	83	1072	0	0	
	4	SB	0	0	0	0	0	1734
34th St & 2nd Ave 2019 (TMC-020)	5							
34th St	5	EB	0	0	591	130	0	
34th St	5	WB	0	0	253	0	0	
2nd Ave	5	NB	0	0	0	0	0	
2nd Ave	5	SB	0	229	1325	45	0	2573
35th St & 2nd Ave 2019 (TMC-021)	6							
35th St	6	EB	0	0	0	476	0	
35th St	6	WB	0	83	88	0	0	
2nd Ave	6	NB	0	0	0	0	0	
2nd Ave	6	SB	0	0	1040	80	0	1767

CBD Tolling
QMT - Traffic Flowmap
PM No-Action



- Legend:**
- 1 - Intersection (2019 Collected Data)
 - 7 - Intersection (Uncollected Data)
 - 100 - ATR Volume
 - 100 - Approach Volume

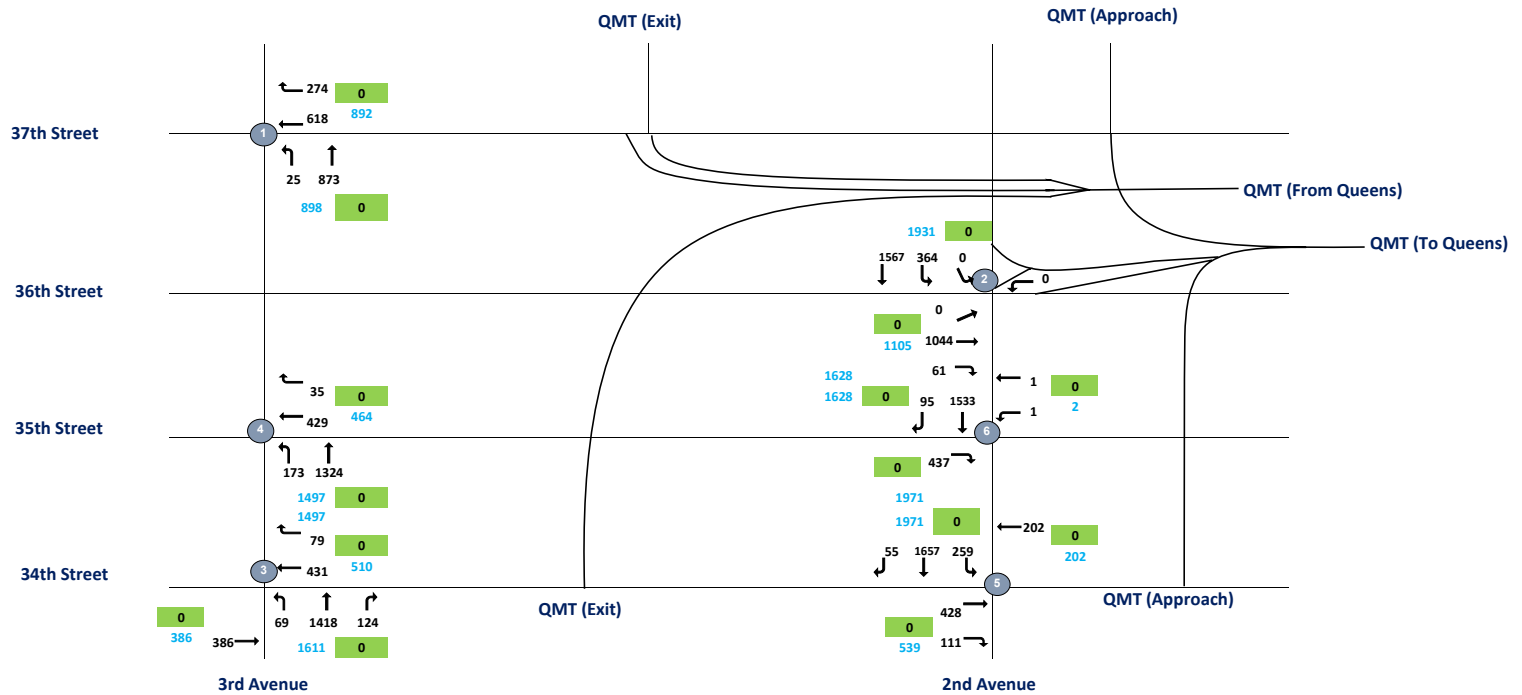

QM

5:00:00 PM

Intersection	Node	Approach	Total Vehicles					
			Inbound/Outbound					Total
			L2	L	T	R	R2	
37th St & 3rd Ave 2019 (TMC-016)	1							
37th St	1	EB	0	0	0	0	0	
37th St	1	WB	0	0	618	274	0	
3rd Ave	1	NB	0	25	873	0	0	
3rd Ave	1	SB	0	0	0	0	0	1790
36th St & 2nd Ave 2019 (TMC-017)	2							
36th St	2	EB	0	0	1044	61	0	
36th St	2	WB	0	0	0	0	0	
2nd Ave	2	NB	0	0	0	0	0	
2nd Ave	2	SB	0	364	1567	0	0	3036
34th St & 3rd Ave 2019 (TMC-018)	3							
34th St	3	EB	0	0	386	0	0	
34th St	3	WB	0	0	431	79	0	
3rd Ave	3	NB	0	69	1418	124	0	
	3	SB	0	0	0	0	0	2507
35th St & 3rd Ave 2019 (TMC-019)	4							
35th St	4	EB	0	0	0	0	0	
35th St	4	WB	0	0	429	35	0	
3rd Ave	4	NB	0	173	1324	0	0	
	4	SB	0	0	0	0	0	1961
34th St & 2nd Ave 2019 (TMC-020)	5							
34th St	5	EB	0	0	428	111	0	
34th St	5	WB	0	0	202	0	0	
2nd Ave	5	NB	0	0	0	0	0	
2nd Ave	5	SB	0	259	1657	55	0	2712
35th St & 2nd Ave 2019 (TMC-021)	6							
35th St	6	EB	0	0	0	437	0	
35th St	6	WB	0	1	1	0	0	
2nd Ave	6	NB	0	0	0	0	0	
2nd Ave	6	SB	0	0	1533	95	0	2067

CBD Tolling
QMT - Traffic Flowmap
LN No-Action



- Legend:**
- 1 - Intersection (2019 Collected Data)
 - 7 - Intersection (Uncollected Data)
 - 100 - ATR Volume
 - 100 - Approach Volume

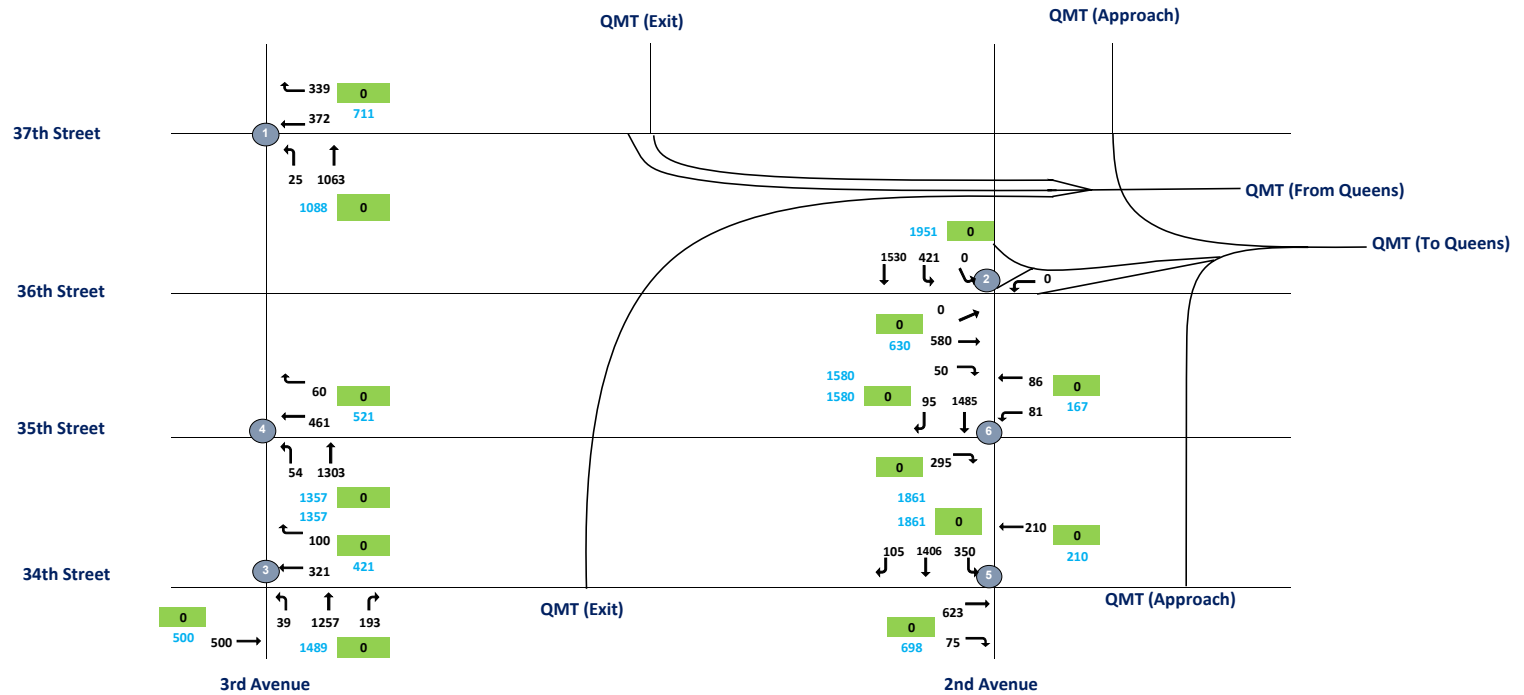

QM

9:00:00 PM

Intersection	Node	Approach	Total Vehicles					
			Inbound/Outbound					
			LN Peak Hour					
			L2	L	T	R	R2	Total
37th St & 3rd Ave 2019 (TMC-016)	1							
37th St	1	EB	0	0	0	0	0	
37th St	1	WB	0	0	372	339	0	
3rd Ave	1	NB	0	25	1063	0	0	
3rd Ave	1	SB	0	0	0	0	0	1799
36th St & 2nd Ave 2019 (TMC-017)	2							
36th St	2	EB	0	0	580	50	0	
36th St	2	WB	0	0	0	0	0	
2nd Ave	2	NB	0	0	0	0	0	
2nd Ave	2	SB	0	421	1530	0	0	2581
34th St & 3rd Ave 2019 (TMC-018)	3							
34th St	3	EB	0	0	500	0	0	
34th St	3	WB	0	0	321	100	0	
3rd Ave	3	NB	0	39	1257	193	0	
	3	SB	0	0	0	0	0	2410
35th St & 3rd Ave 2019 (TMC-019)	4							
35th St	4	EB	0	0	0	0	0	
35th St	4	WB	0	0	461	60	0	
3rd Ave	4	NB	0	54	1303	0	0	
	4	SB	0	0	0	0	0	1878
34th St & 2nd Ave 2019 (TMC-020)	5							
34th St	5	EB	0	0	623	75	0	
34th St	5	WB	0	0	210	0	0	
2nd Ave	5	NB	0	0	0	0	0	
2nd Ave	5	SB	0	350	1406	105	0	2769
35th St & 2nd Ave 2019 (TMC-021)	6							
35th St	6	EB	0	0	0	295	0	
35th St	6	WB	0	81	86	0	0	
2nd Ave	6	NB	0	0	0	0	0	
2nd Ave	6	SB	0	0	1485	95	0	2042

CBD Tolling
RKB - Traffic Flowmap
AM No-Action



- Legend:**
- 1 - Intersection (2019 Collected Data)
 - 7 - Intersection (Uncollected Data)
 - 100 - ATR Volume
 - 100 - Approach Volume

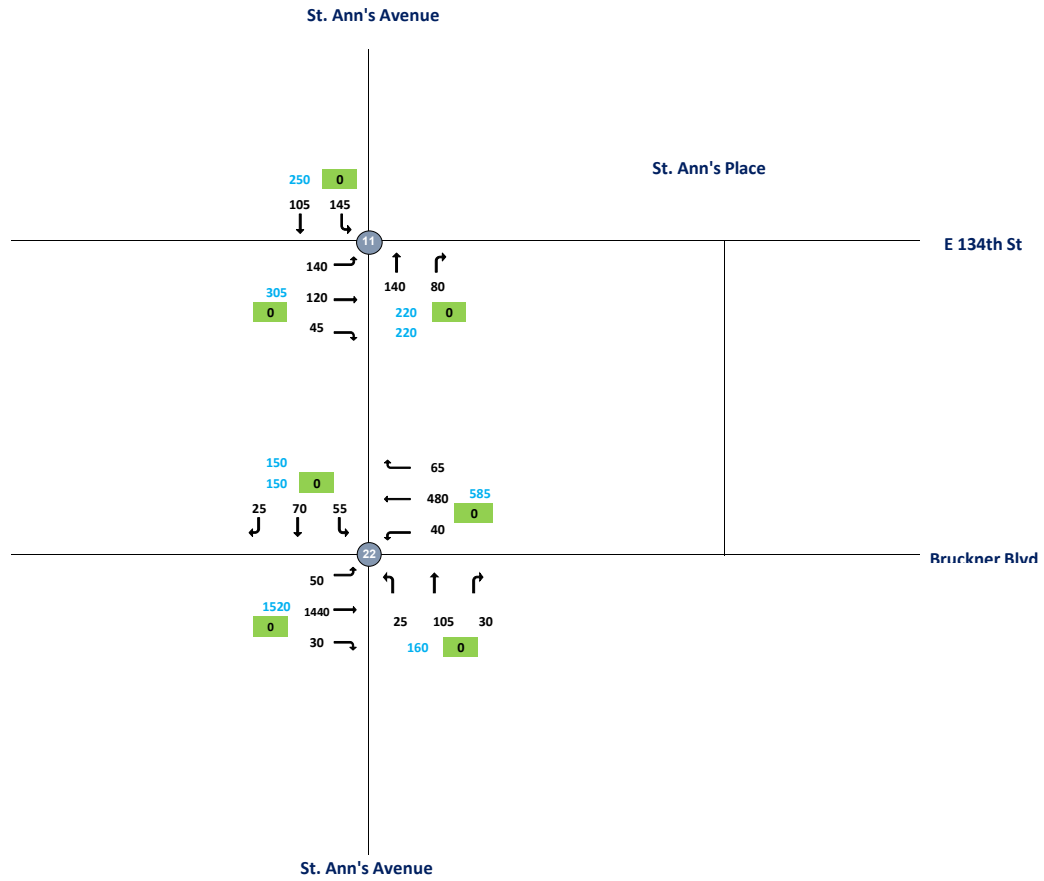

RKB

8:00 AM

Intersection	Node	Approach	Total Vehicles					
			Inbound/Outbound					Total
			AM Peak Hour					
L2	L	T	R	R2	Total			
E 134th Street and St. Ann's Ave 2019 (TMC-060)	11							
E 134th Street	11	EB	0	140	120	45	0	
E 134th Street	11	WB	0	0	0	0	0	
St. Ann's Ave	11	NB	0	0	140	80	0	
St. Ann's Ave	11	SB	0	145	105	0	0	775
Bruckner Blvd and St. Ann's Ave 2019 (TMC-061)	22							
Bruckner Blvd	22	EB	0	50	1440	30	0	
Bruckner Blvd	22	WB	0	40	480	65	0	
St. Ann's Ave	22	NB	0	25	105	30	0	
St. Ann's Ave	22	SB	0	55	70	25	0	2415

CBD Tolling
AS - Traffic Flowmap
AM No-Action



- Legend:**
- 1 - Intersection (2019 Collected Data)
 - 7 - Intersection (Uncollected Data)
 - 100 - ATR Volume
 - 100 - Approach Volume

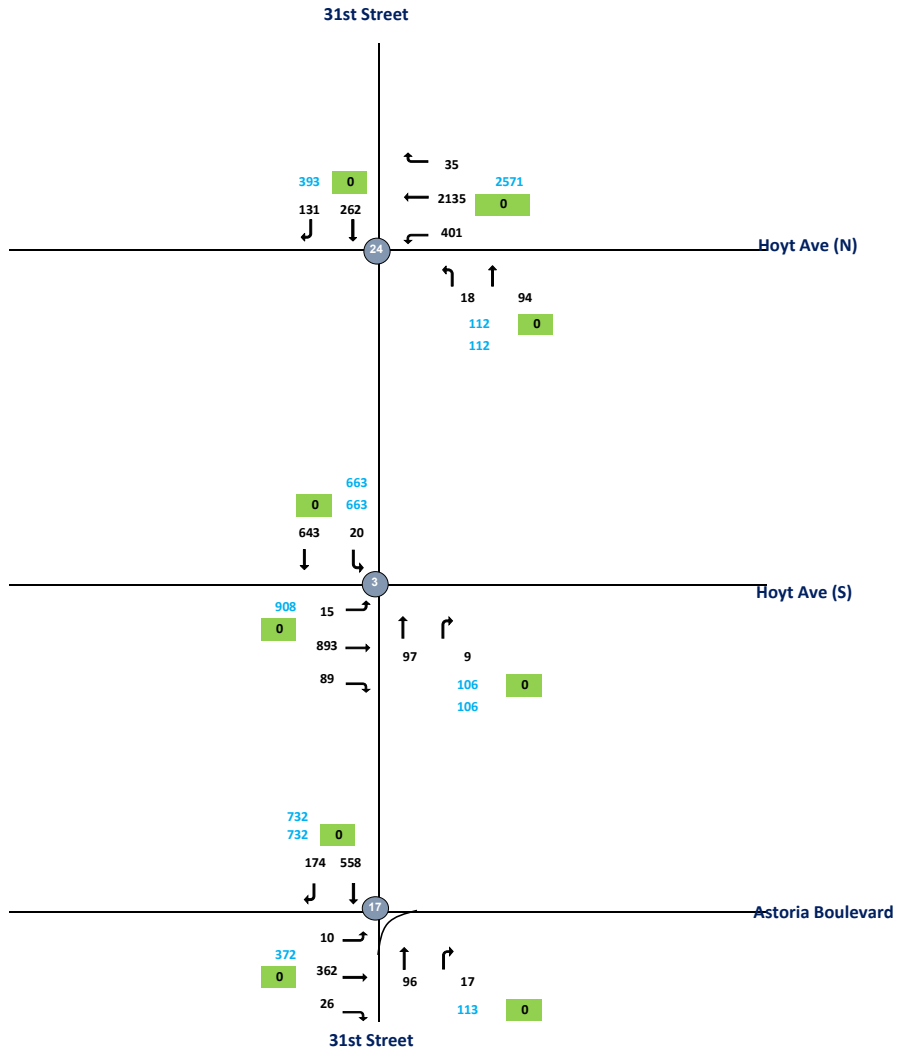

AS

7:15:00 AM

Intersection	Node	Approach	Total Vehicles					
			Inbound/Outbound					
			AM Peak Hour					
			L2	L	T	R	R2	Total
31st Street and Astoria Blvd 2019 (TMC-062)	17							
Astoria Blvd	17	EB	0	10	362	26	0	
Astoria Blvd	17	WB	0	0	0	0	0	
31st Street	17	NB	0	0	96	17	0	
31st Street	17	SB	0	0	558	174	0	1243
31st Street and Hoyt Ave N 2019 (TMC-063)	24							
Hoyt Ave N	24	EB	0	0	0	0	0	
Hoyt Ave N	24	WB	0	401	2135	35	0	
31st Street	24	NB	0	18	94	0	0	
31st Street	24	SB	0	0	262	131	0	3076
31st Street and Hoyt Ave S 2019 (TMC-064)	3							
Hoyt Ave S	3	EB	0	15	893	89	0	
	3		0	0	0	0	0	
31st Street	3	NB	0	0	97	9	0	
31st Street	3	SB	0	20	643	0	0	1766

CBD Tolling
RKM - Traffic Flowmap
AM No-Action



- Legend:**
- 1 - Intersection (2019 Collected Data)
 - 7 - Intersection (Uncollected Data)
 - 100 - ATR Volume
 - 100 - Approach Volume

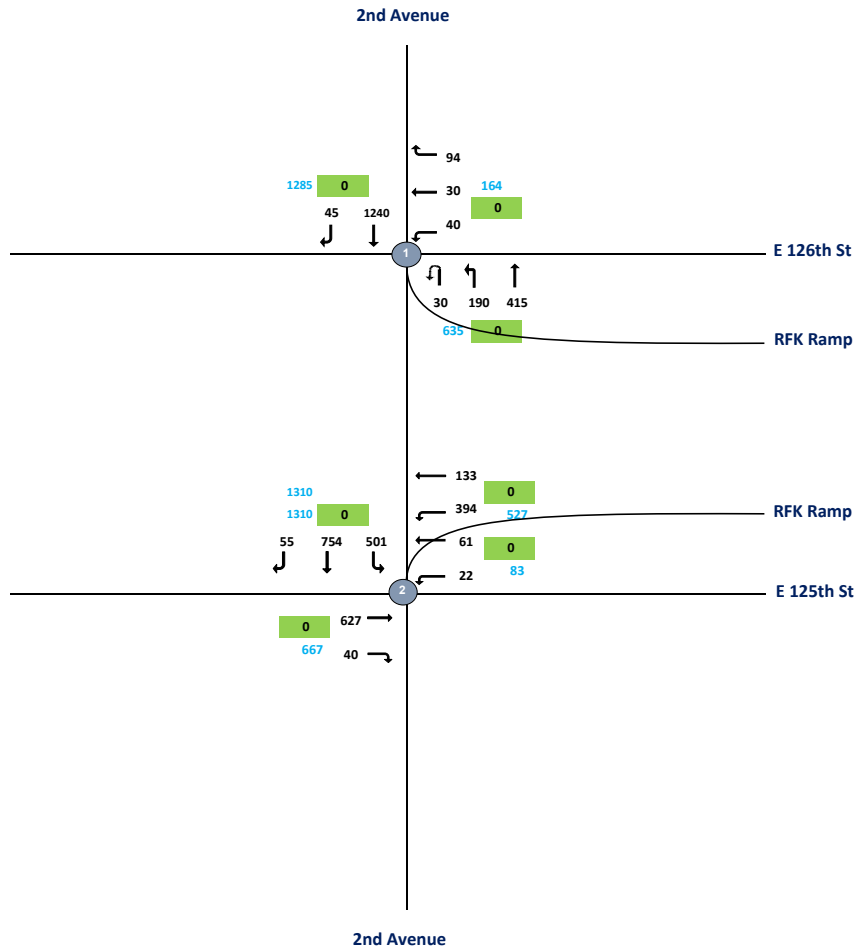

RKM

7:45 AM

Intersection	Node	Approach	Total Vehicles						Total
			Inbound/Outbound						
			AM Peak Hour						
			L2	L	T	R	R2		
E 126th Street and 2nd Ave									
2019 (TMC-058)									
RFK Ramp	1	NW	30	190	0	415	0		
E 126th Street	1	EB	0	0	0	0	0		
E 126th Street	1	WB	0	40	30	94	0		
2nd Ave	1	NB	0	0	0	0	0		
2nd Ave	1	SB	0	0	1240	45	0	1449	
E 125th Street and 2nd Ave									
2019 (TMC-059)									
E 125th Street	2	EB	0	0	627	40	0		
E 125th Street	2	WB	0	22	61	0	0		
2nd Ave	2	SW	0	394	0	133	0		
2nd Ave	2	SB	0	501	754	55	0	2587	

CBD Tolling
RKB - Traffic Flowmap
MD No-Action



- Legend:**
- ① - Intersection (2019 Collected Data)
 - ⑦ - Intersection (Uncollected Data)
 - 100 - ATR Volume
 - 100 - Approach Volume

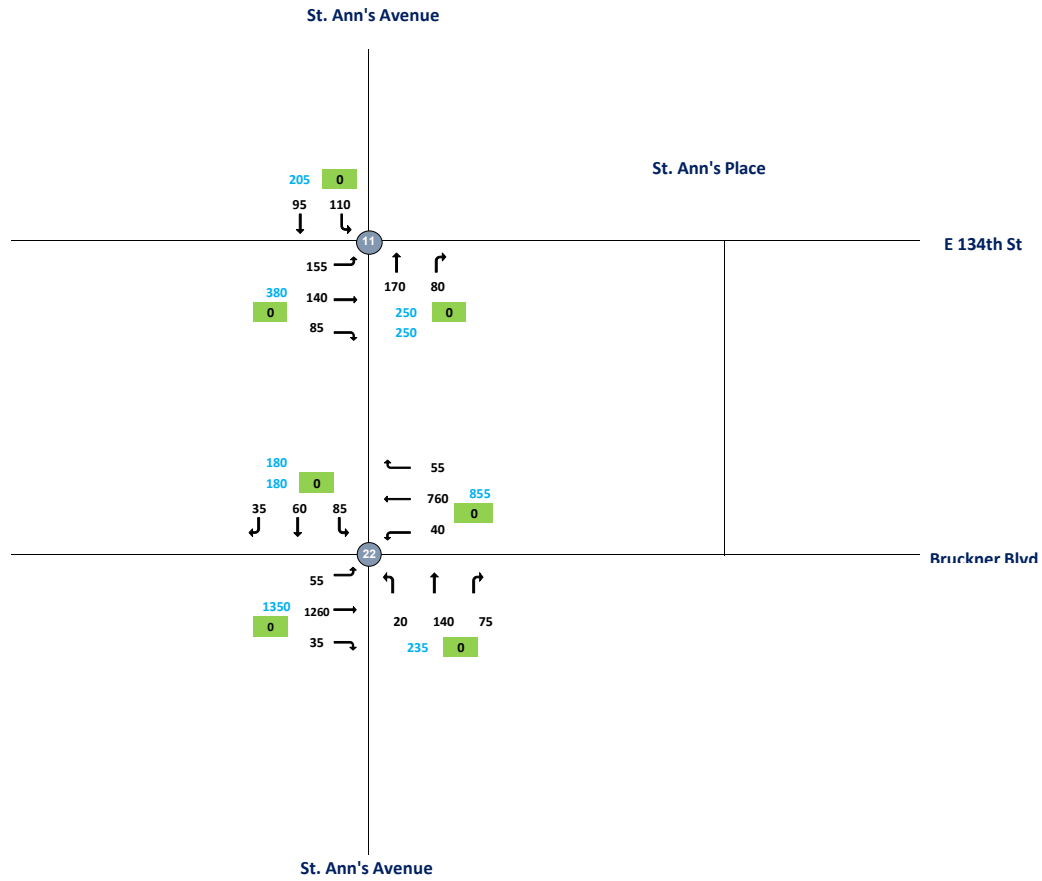

RKB

Intersection	Node	Approach	Total Vehicles						
			Inbound/Outbound						
			MD Peak Hour						
			L2	L	T	R	R2	Total	
E 134th Street and St. Ann's Ave 2019 (TMC-060)	11								
E 134th Street	11	EB	0	155	140	85	0		
E 134th Street	11	WB	0	0	0	0	0		
St. Ann's Ave	11	NB	0	0	170	80	0		
St. Ann's Ave	11	SB	0	110	95	0	0	835	
Bruckner Blvd and St. Ann's Ave 2019 (TMC-061)	22								
Bruckner Blvd	22	EB	0	55	1260	35	0		
Bruckner Blvd	22	WB	0	40	760	55	0		
St. Ann's Ave	22	NB	0	20	140	75	0		
St. Ann's Ave	22	SB	0	85	60	35	0	2620	

CBD Tolling
AS - Traffic Flowmap
MD No-Action



- Legend:**
- 1 - Intersection (2019 Collected Data)
 - 7 - Intersection (Uncollected Data)
 - 100 - ATR Volume
 - 100 - Approach Volume

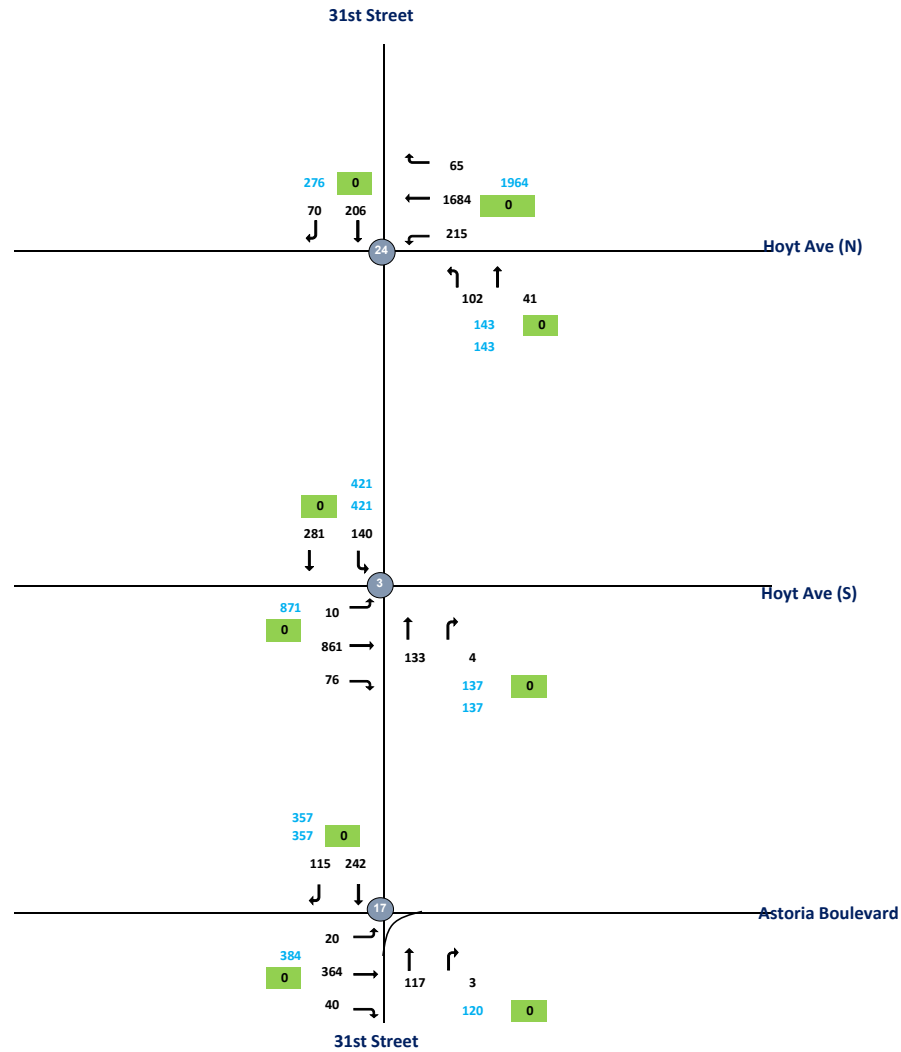

AS

Intersection	Node	Approach	Total Vehicles					
			Inbound/Outbound					
			MD Peak Hour					
			L2	L	T	R	R2	Total
31st Street and Astoria Blvd 2019 (TMC-062)	17							
Astoria Blvd	17	EB	0	20	364	40	0	
Astoria Blvd	17	WB	0	0	0	0	0	
31st Street	17	NB	0	0	117	3	0	
31st Street	17	SB	0	0	242	115	0	901
31st Street and Hoyt Ave N 2019 (TMC-063)	24							
Hoyt Ave N	24	EB	0	0	0	0	0	
Hoyt Ave N	24	WB	0	215	1684	65	0	
31st Street	24	NB	0	102	41	0	0	
31st Street	24	SB	0	0	206	70	0	2383
31st Street and Hoyt Ave S 2019 (TMC-064)	3							
Hoyt Ave S	3	EB	0	10	861	76	0	
	3		0	0	0	0	0	
31st Street	3	NB	0	0	133	4	0	
31st Street	3	SB	0	140	281	0	0	1505

CBD Tolling
RKM - Traffic Flowmap
MD No-Action



- Legend:**
- 1 - Intersection (2019 Collected Data)
 - 7 - Intersection (Uncollected Data)
 - 100 - ATR Volume
 - 100 - Approach Volume

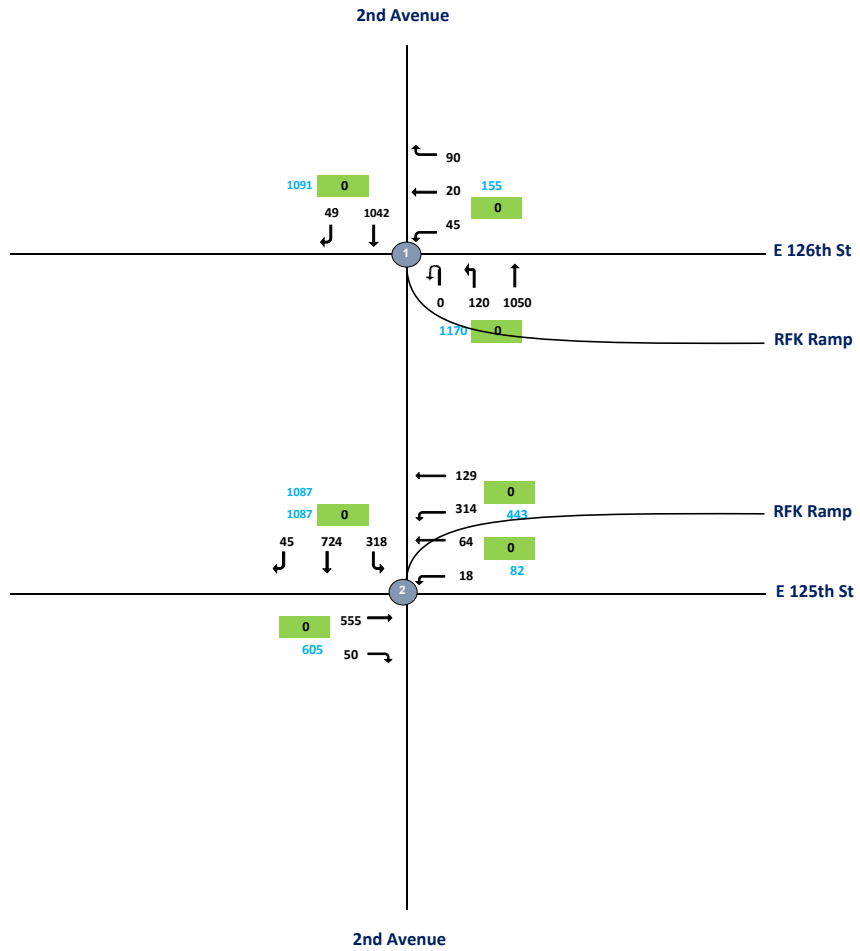

RKM

Intersection	Node	Approach	Total Vehicles						Total
			Inbound/Outbound						
			MD Peak Hour						
			L2	L	T	R	R2		
E 126th Street and 2nd Ave 2019 (TMC-058)									
RFK Ramp	1	NW	0	120	0	1050	0		
E 126th Street	1	EB	0	0	0	0	0		
E 126th Street	1	WB	0	45	20	90	0		
2nd Ave	1	NB	0	0	0	0	0		
2nd Ave	1	SB	0	0	1042	49	0	1246	
E 125th Street and 2nd Ave 2019 (TMC-059)									
E 125th Street	2	EB	0	0	555	50	0		
E 125th Street	2	WB	0	18	64	0	0		
2nd Ave	2	SW	0	314	0	129	0		
2nd Ave	2	SB	0	318	724	45	0	2217	

CBD Tolling
RKB - Traffic Flowmap
PM No-Action



- Legend:**
- ① - Intersection (2019 Collected Data)
 - ⑦ - Intersection (Uncollected Data)
 - 100 - ATR Volume
 - 100 - Approach Volume

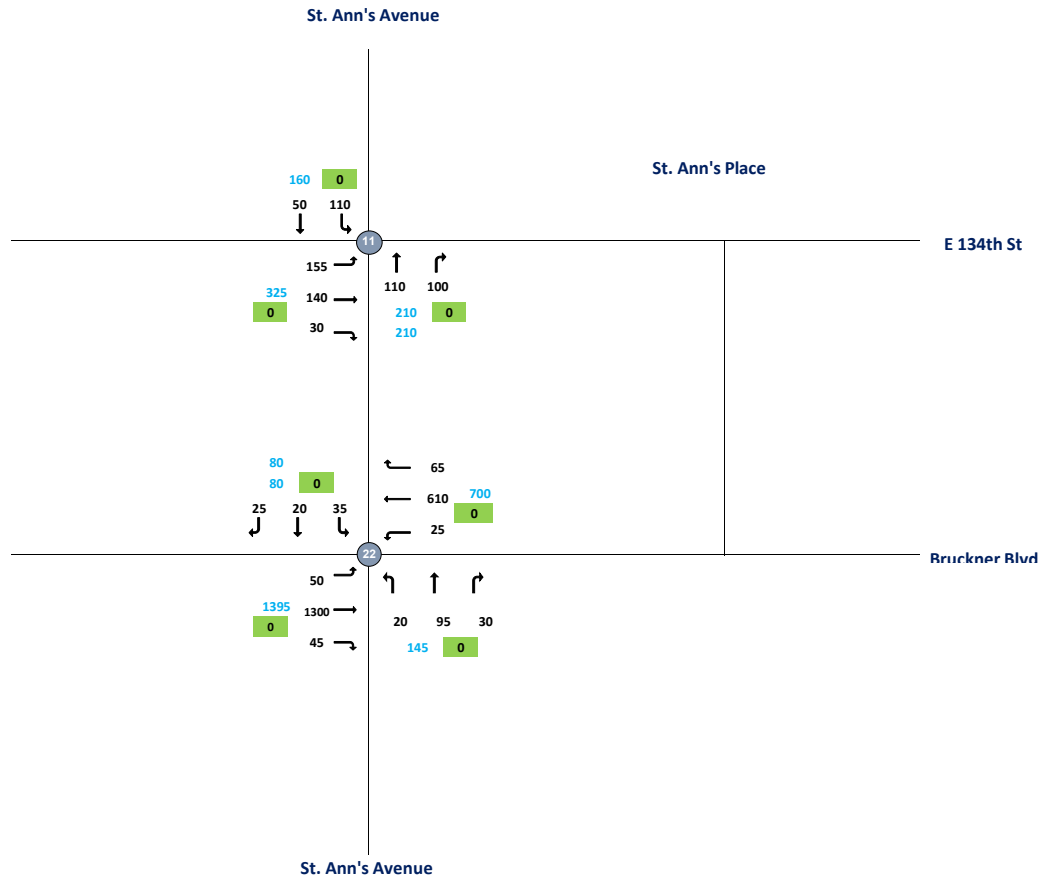

RKB

Intersection	Node	Approach	Total Vehicles						
			Inbound/Outbound						
			PM Peak Hour						
			L2	L	T	R	R2	Total	
E 134th Street and St. Ann's Ave 2019 (TMC-060)	11								
E 134th Street	11	EB	0	155	140	30	0		
E 134th Street	11	WB	0	0	0	0	0		
St. Ann's Ave	11	NB	0	0	110	100	0		
St. Ann's Ave	11	SB	0	110	50	0	0		695
Bruckner Blvd and St. Ann's Ave 2019 (TMC-061)	22								
Bruckner Blvd	22	EB	0	50	1300	45	0		
Bruckner Blvd	22	WB	0	25	610	65	0		
St. Ann's Ave	22	NB	0	20	95	30	0		
St. Ann's Ave	22	SB	0	35	20	25	0		2320

CBD Tolling
AS - Traffic Flowmap
PM No-Action



- Legend:**
- 1 - Intersection (2019 Collected Data)
 - 7 - Intersection (Uncollected Data)
 - 100 - ATR Volume
 - 100 - Approach Volume

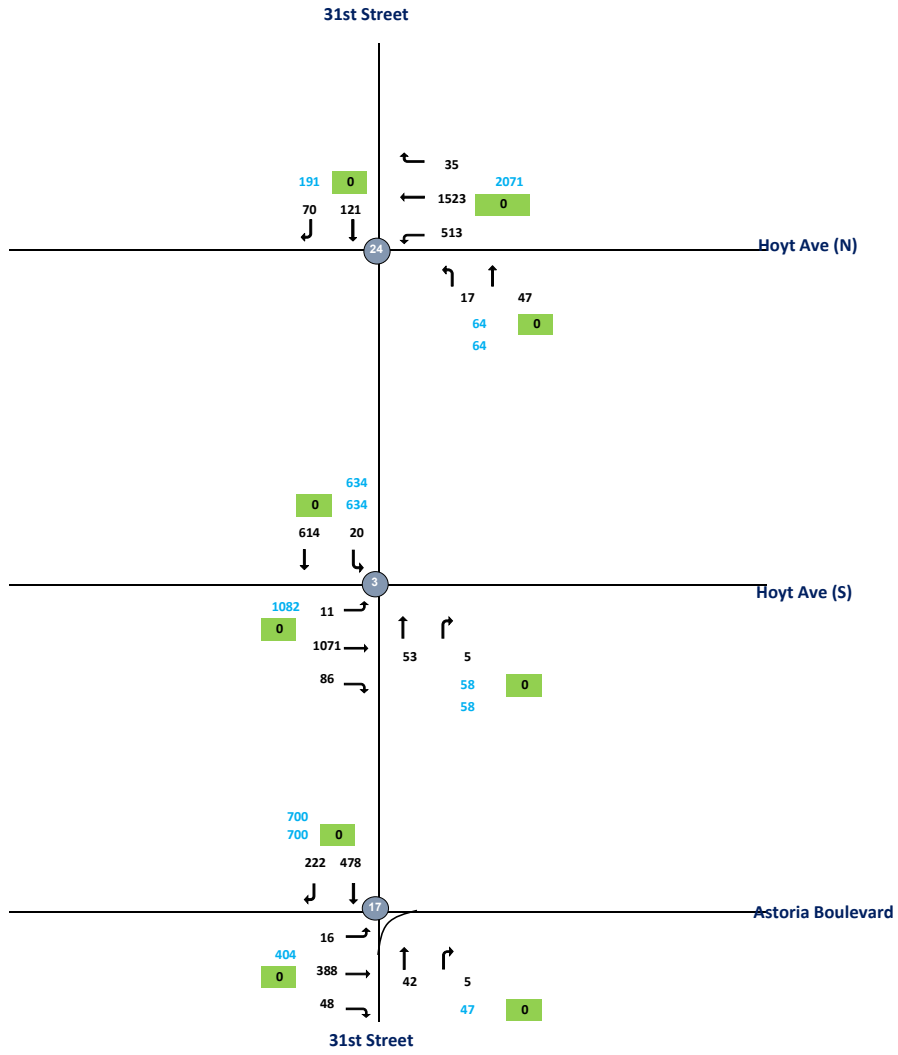

AS

Intersection	Node	Approach	Total Vehicles					
			Inbound/Outbound					
			PM Peak Hour					
			L2	L	T	R	R2	Total
31st Street and Astoria Blvd 2019 (TMC-062)	17							
Astoria Blvd	17	EB	0	16	388	48	0	
Astoria Blvd	17	WB	0	0	0	0	0	
31st Street	17	NB	0	0	42	5	0	
31st Street	17	SB	0	0	478	222	0	1199
31st Street and Hoyt Ave N 2019 (TMC-063)	24							
Hoyt Ave N	24	EB	0	0	0	0	0	
Hoyt Ave N	24	WB	0	513	1523	35	0	
31st Street	24	NB	0	17	47	0	0	
31st Street	24	SB	0	0	121	70	0	2326
31st Street and Hoyt Ave S 2019 (TMC-064)	3							
Hoyt Ave S	3	EB	0	11	1071	86	0	
	3		0	0	0	0	0	
31st Street	3	NB	0	0	53	5	0	
31st Street	3	SB	0	20	614	0	0	1860

CBD Tolling
RKM - Traffic Flowmap
PM No-Action



- Legend:**
- 1 - Intersection (2019 Collected Data)
 - 2 - Intersection (Uncollected Data)
 - 100 - ATR Volume
 - 100 - Approach Volume

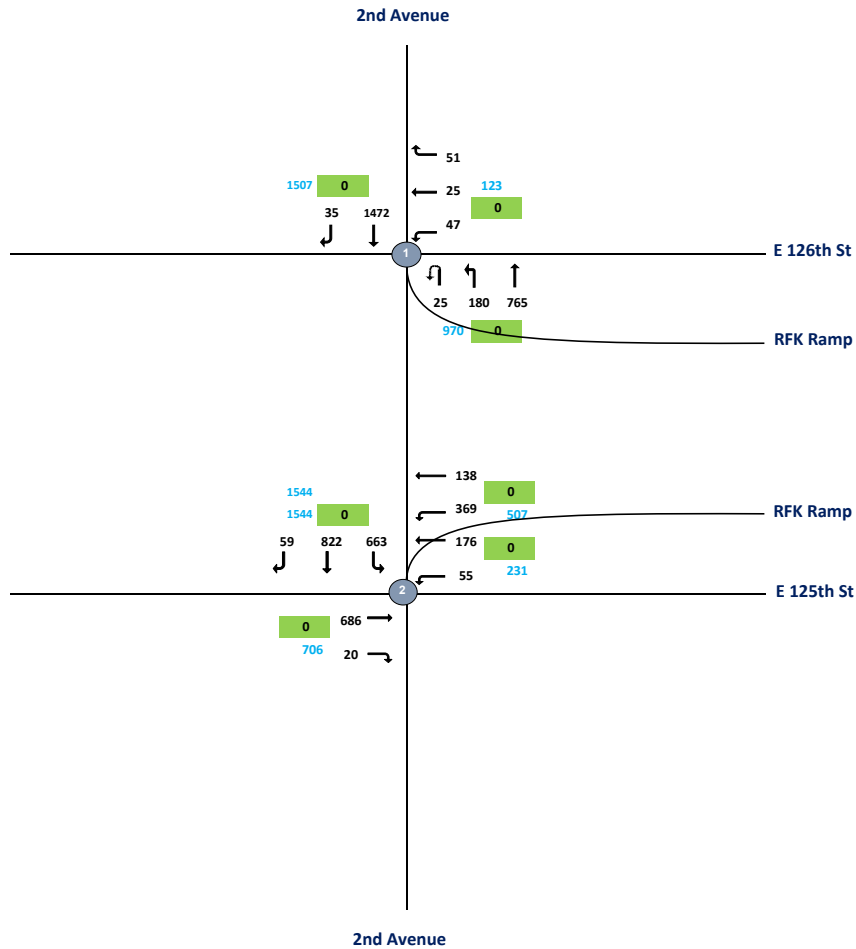

RKM

Intersection	Node	Approach	Total Vehicles						Total
			Inbound/Outbound						
			PM Peak Hour						
			L2	L	T	R	R2		
E 126th Street and 2nd Ave 2019 (TMC-058)									
RFK Ramp	1	NW	25	180	0	765	0		
E 126th Street	1	EB	0	0	0	0	0		
E 126th Street	1	WB	0	47	25	51	0		
2nd Ave	1	NB	0	0	0	0	0		
2nd Ave	1	SB	0	0	1472	35	0	1630	
E 125th Street and 2nd Ave 2019 (TMC-059)									
E 125th Street	2	EB	0	0	686	20	0		
E 125th Street	2	WB	0	55	176	0	0		
2nd Ave	2	SW	0	369	0	138	0		
2nd Ave	2	SB	0	663	822	59	0	2988	

CBD Tolling
RKB - Traffic Flowmap
LN No-Action



- Legend:**
- ① - Intersection (2019 Collected Data)
 - ⑦ - Intersection (Uncollected Data)
 - 100 - ATR Volume
 - 100 - Approach Volume

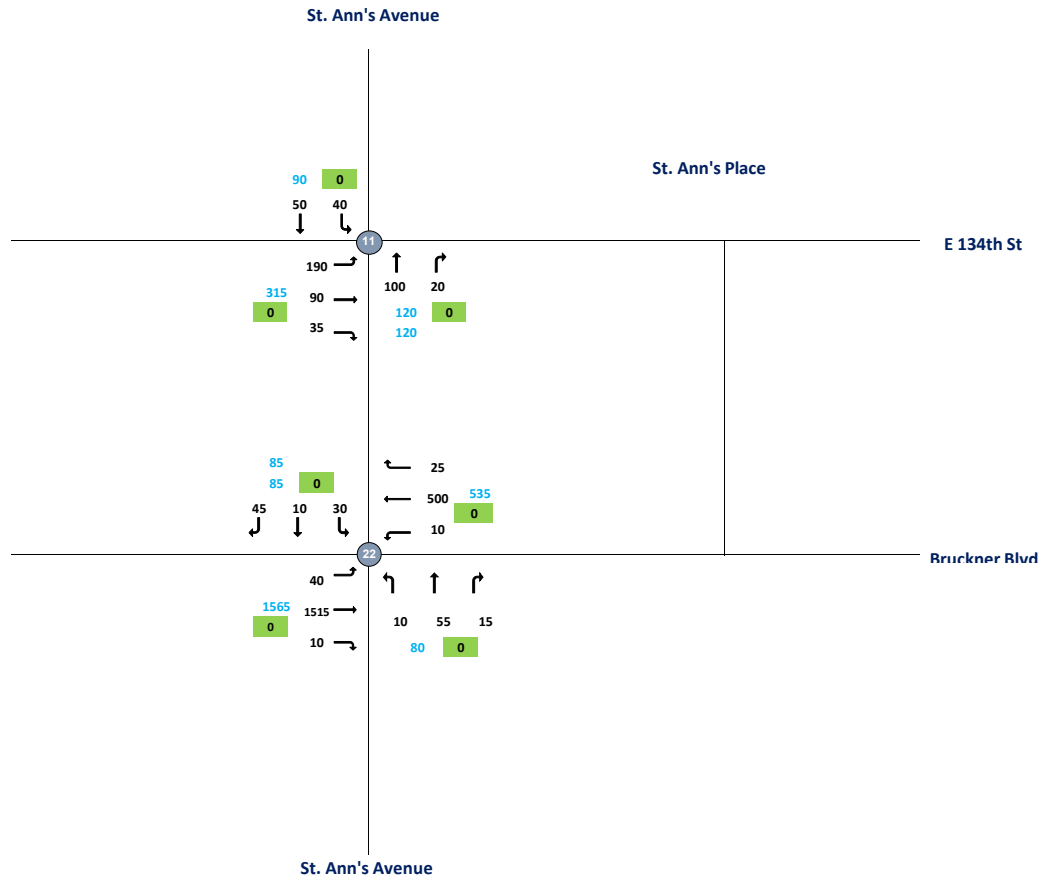

RKB

Intersection	Node	Approach	Total Vehicles					
			Inbound/Outbound					Total
			L2	L	T	R	R2	
E 134th Street and St. Ann's Ave 2019 (TMC-060)								
E 134th Street	11	EB	0	190	90	35	0	
E 134th Street	11	WB	0	0	0	0	0	
St. Ann's Ave	11	NB	0	0	100	20	0	
St. Ann's Ave	11	SB	0	40	50	0	0	525
Bruckner Blvd and St. Ann's Ave 2019 (TMC-061)								
Bruckner Blvd	22	EB	0	40	1515	10	0	
Bruckner Blvd	22	WB	0	10	500	25	0	
St. Ann's Ave	22	NB	0	10	55	15	0	
St. Ann's Ave	22	SB	0	30	10	45	0	2265

CBD Tolling
AS - Traffic Flowmap
LN No-Action



- Legend:**
- 1 - Intersection (2019 Collected Data)
 - 7 - Intersection (Uncollected Data)
 - 100 - ATR Volume
 - 100 - Approach Volume

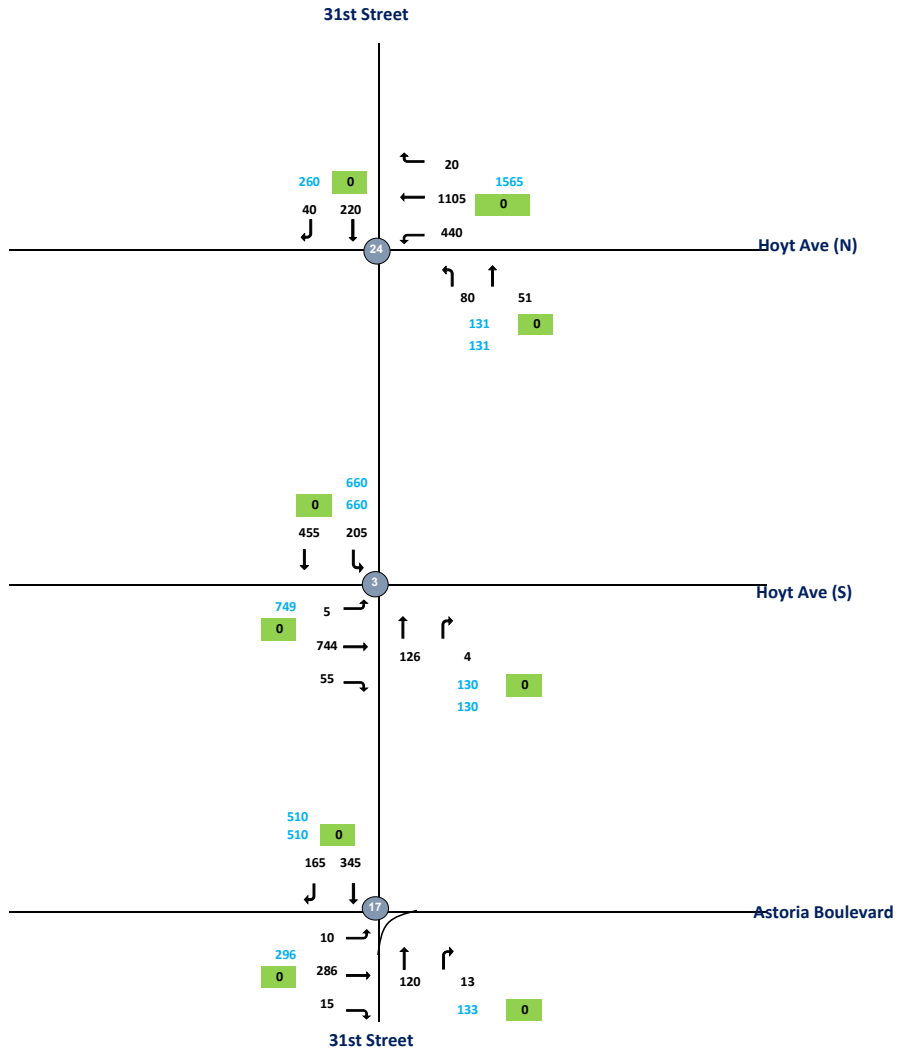

AS

Intersection	Node	Approach	Total Vehicles						
			Inbound/Outbound					Total	
			LN Peak Hour						
			L2	L	T	R	R2		
31st Street and Astoria Blvd 2019 (TMC-062)	17								
Astoria Blvd	17	EB	0	10	286	15	0		
Astoria Blvd	17	WB	0	0	0	0	0		
31st Street	17	NB	0	0	120	13	0		
31st Street	17	SB	0	0	345	165	0		954
31st Street and Hoyt Ave N 2019 (TMC-063)	24								
Hoyt Ave N	24	EB	0	0	0	0	0		
Hoyt Ave N	24	WB	0	440	1105	20	0		
31st Street	24	NB	0	80	51	0	0		
31st Street	24	SB	0	0	220	40	0		1956
31st Street and Hoyt Ave S 2019 (TMC-064)	3								
Hoyt Ave S	3	EB	0	5	744	55	0		
	3		0	0	0	0	0		
31st Street	3	NB	0	0	126	4	0		
31st Street	3	SB	0	205	455	0	0		1594

CBD Tolling
RKM - Traffic Flowmap
LN No-Action



- Legend:**
- 1 - Intersection (2019 Collected Data)
 - 2 - Intersection (Uncollected Data)
 - 100 - ATR Volume
 - 100 - Approach Volume

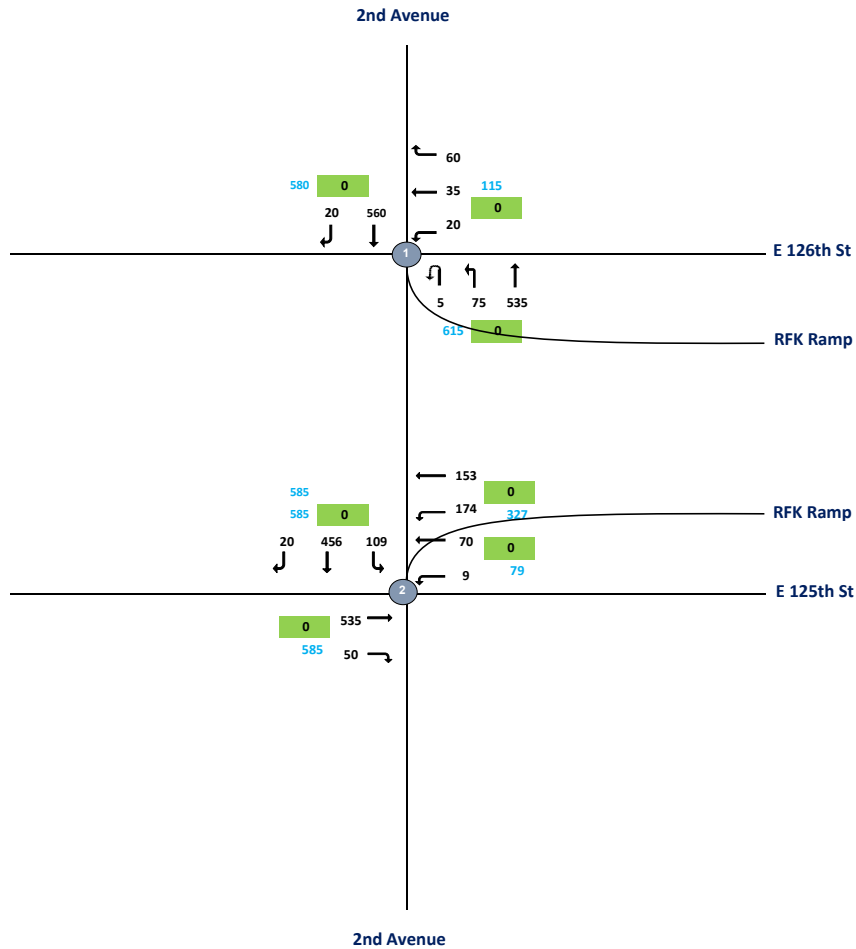

RKM

7:45 AM

Intersection	Node	Approach	Total Vehicles						Total
			Inbound/Outbound						
			LN Peak Hour						
			L2	L	T	R	R2		
E 126th Street and 2nd Ave 2019 (TMC-058)									
RFK Ramp	1	NW	5	75	0	535	0		
E 126th Street	1	EB	0	0	0	0	0		
E 126th Street	1	WB	0	20	35	60	0		
2nd Ave	1	NB	0	0	0	0	0		
2nd Ave	1	SB	0	0	560	20	0	695	
E 125th Street and 2nd Ave 2019 (TMC-059)	2								
E 125th Street	2	EB	0	0	535	50	0		
E 125th Street	2	WB	0	9	70	0	0		
2nd Ave	2	SW	0	174	0	153	0		
2nd Ave	2	SB	0	109	456	20	0	1576	

CBD Tolling
Red Hook- Traffic Flowmap
AM No-Action



- Legend:**
- 1 - Intersection (2019 Collected Data)
 - 7 - Intersection (Uncollected Data)
 - 100 - ATR Volume
 - 100 - Approach Volume

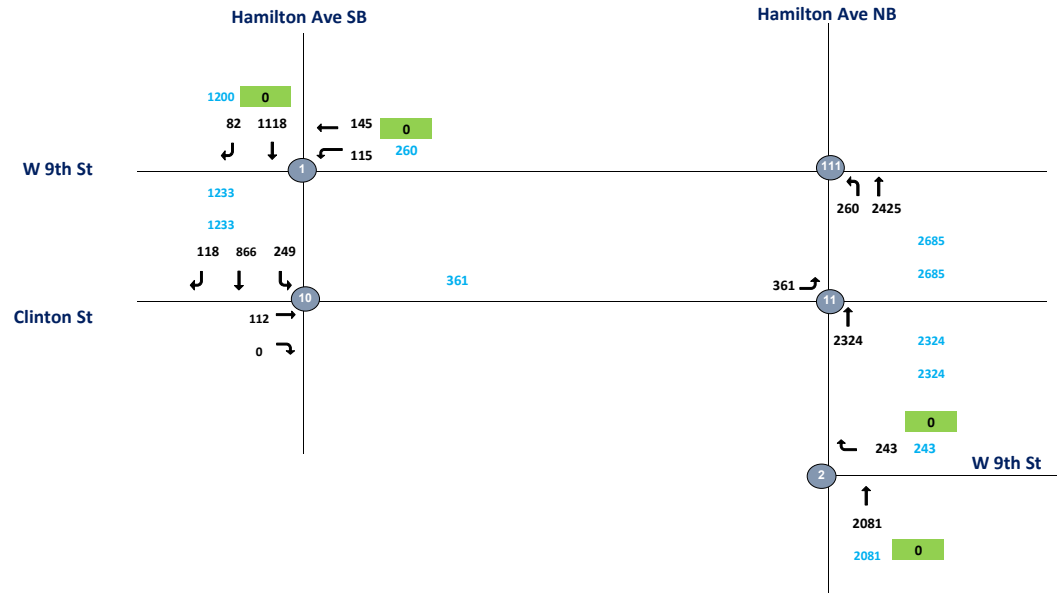

RH

7:45:00 AM

Intersection	Node	Approach	Total Vehicles					Total
			Inbound/Outbound					
			AM Peak Hour					
			L2	L	T	R	R2	
Hamilton Ave SB & W 9th St 2019 (TMC-040)	1							
W 9th St	1	EB	0	0	0	0	0	
W 9th St	1	WB	0	115	145	0	0	
Hamilton Ave SB	1		0	0	0	0	0	
Hamilton Ave SB	1	SB	0	0	1118	82	0	1460
Hamilton Ave SB & W 9th St 2019 (TMC-040)	10							
Clinton Avenue	10	EB	0	0	112	0	0	
Clinton Avenue	10	WB	0	0	0	0	0	
Hamilton Ave SB	10		0	0	0	0	0	
Hamilton Ave SB	10	SB	0	249	866	118	0	1345
Hamilton Ave SB & W 9th St 2019 (TMC-040)	11							
Clinton Avenue	11	EB	0	361	0	0	0	
Clinton Avenue	11		0	0	0	0	0	
Hamilton Ave	11	NB	0	0	2324	0	0	
Hamilton Ave	11		0	0	0	0	0	2685
Hamilton Ave SB & W 9th St 2019 (TMC-040)	111							
W 9th St	111	EB	0	0	0	0	0	
W 9th St	111	WB	0	0	0	0	0	
Hamilton Ave	111	NB	0	260	2425	0	0	
-	111	SB	0	0	0	0	0	2685
Hamilton Ave NB & W 9th St 2019 (TMC-041)	2							
W 9th St	2	EB	0	0	0	0	0	
W 9th St	2	WB	0	0	0	243	0	
Hamilton Ave	2	NB	0	0	2081	0	0	
Hamilton Ave	2	SB	0	0	0	0	0	2324

CBD Tolling
Red Hook- Traffic Flowmap
MD No-Action



- Legend:**
- 1 - Intersection (2019 Collected Data)
 - 7 - Intersection (Uncollected Data)
 - 100 - ATR Volume
 - 100 - Approach Volume

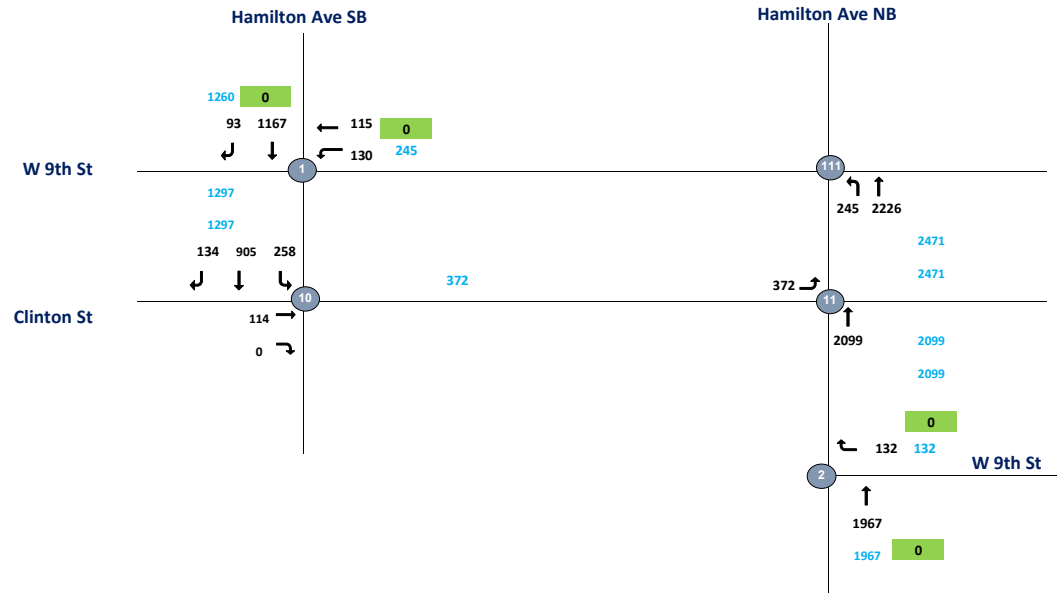

RH

12:00:00 PM

Intersection	Node	Approach	Total Vehicles					Total
			Inbound/Outbound					
			MD Peak Hour					
			L2	L	T	R	R2	
Hamilton Ave SB & W 9th St 2019 (TMC-040)	1							
W 9th St	1	EB	0	0	0	0	0	
W 9th St	1	WB	0	130	115	0	0	
Hamilton Ave SB	1		0	0	0	0	0	
Hamilton Ave SB	1	SB	0	0	1167	93	0	1505
Hamilton Ave SB & W 9th St 2019 (TMC-040)	10							
Clinton Avenue	10	EB	0	0	114	0	0	
Clinton Avenue	10	WB	0	0	0	0	0	
Hamilton Ave SB	10		0	0	0	0	0	
Hamilton Ave SB	10	SB	0	258	905	134	0	1411
Hamilton Ave SB & W 9th St 2019 (TMC-040)	11							
Clinton Avenue	11	EB	0	372	0	0	0	
Clinton Avenue	11		0	0	0	0	0	
Hamilton Ave	11	NB	0	0	2099	0	0	
Hamilton Ave	11		0	0	0	0	0	2471
Hamilton Ave SB & W 9th St 2019 (TMC-040)	111							
W 9th St	111	EB	0	0	0	0	0	
W 9th St	111	WB	0	0	0	0	0	
Hamilton Ave	111	NB	0	245	2226	0	0	
-	111	SB	0	0	0	0	0	2471
Hamilton Ave NB & W 9th St 2019 (TMC-041)	2							
W 9th St	2	EB	0	0	0	0	0	
W 9th St	2	WB	0	0	0	132	0	
Hamilton Ave	2	NB	0	0	1967	0	0	
Hamilton Ave	2	SB	0	0	0	0	0	2099

CBD Tolling
Red Hook- Traffic Flowmap
PM No-Action



- Legend:**
- 1 - Intersection (2019 Collected Data)
 - 7 - Intersection (Uncollected Data)
 - 100 - ATR Volume
 - 100 - Approach Volume

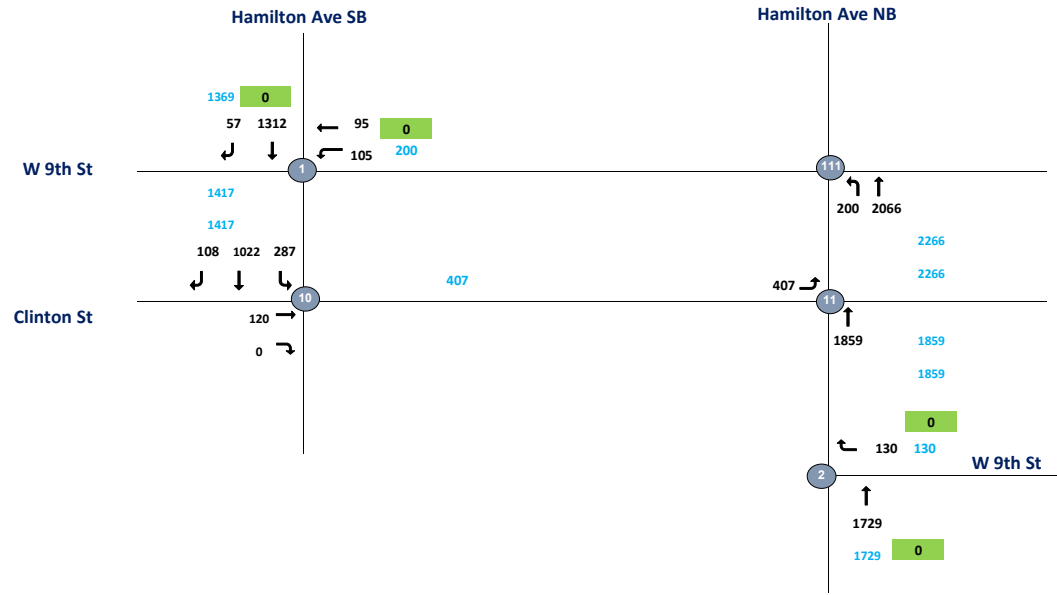

RH

4:00:00 PM

Intersection	Node	Approach	Total Vehicles					Total
			Inbound/Outbound					
			PM Peak Hour					
			L2	L	T	R	R2	
Hamilton Ave SB & W 9th St 2019 (TMC-040)	1							
W 9th St	1	EB	0	0	0	0	0	
W 9th St	1	WB	0	105	95	0	0	
Hamilton Ave SB	1		0	0	0	0	0	
Hamilton Ave SB	1	SB	0	0	1312	57	0	1569
Hamilton Ave SB & W 9th St 2019 (TMC-040)	10							
Clinton Avenue	10	EB	0	0	120	0	0	
Clinton Avenue	10	WB	0	0	0	0	0	
Hamilton Ave SB	10		0	0	0	0	0	
Hamilton Ave SB	10	SB	0	287	1022	108	0	1537
Hamilton Ave SB & W 9th St 2019 (TMC-040)	11							
Clinton Avenue	11	EB	0	407	0	0	0	
Clinton Avenue	11		0	0	0	0	0	
Hamilton Ave	11	NB	0	0	1859	0	0	
Hamilton Ave	11		0	0	0	0	0	2266
Hamilton Ave SB & W 9th St 2019 (TMC-040)	111							
W 9th St	111	EB	0	0	0	0	0	
W 9th St	111	WB	0	0	0	0	0	
Hamilton Ave	111	NB	0	200	2066	0	0	
-	111	SB	0	0	0	0	0	2266
Hamilton Ave NB & W 9th St 2019 (TMC-041)	2							
W 9th St	2	EB	0	0	0	0	0	
W 9th St	2	WB	0	0	0	130	0	
Hamilton Ave	2	NB	0	0	1729	0	0	
Hamilton Ave	2	SB	0	0	0	0	0	1859

CBD Tolling
Red Hook- Traffic Flowmap
LN No-Action



- Legend:**
- 1 - Intersection (2019 Collected Data)
 - 7 - Intersection (Uncollected Data)
 - 100 - ATR Volume
 - 100 - Approach Volume

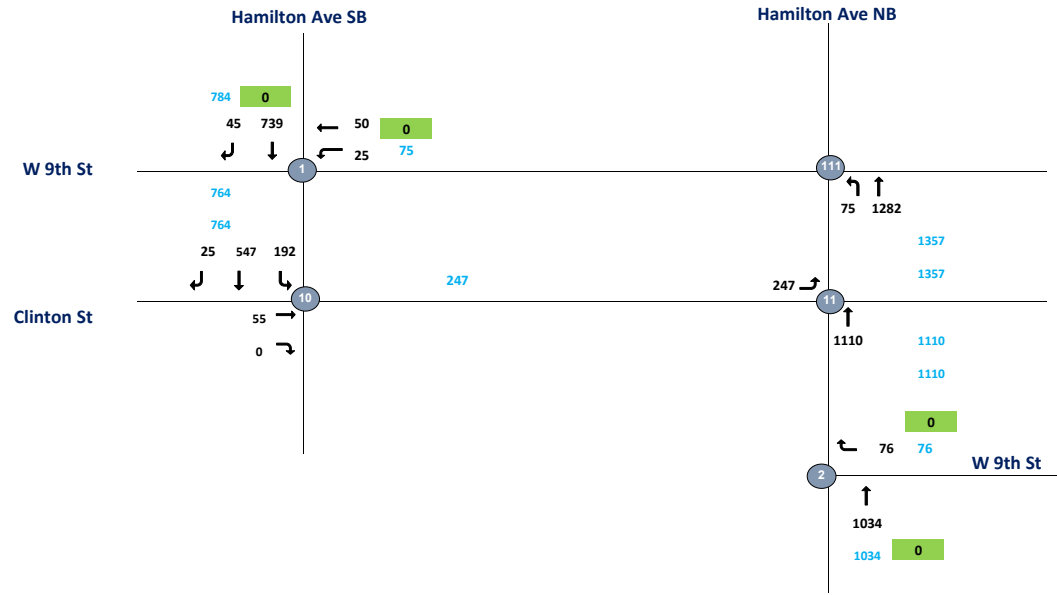

RH

9:00:00 PM

Intersection	Node	Approach	Total Vehicles					Total
			Inbound/Outbound					
			LN Peak Hour					
			L2	L	T	R	R2	
Hamilton Ave SB & W 9th St 2019 (TMC-040)	1							
W 9th St	1	EB	0	0	0	0	0	
W 9th St	1	WB	0	25	50	0	0	
Hamilton Ave SB	1		0	0	0	0	0	
Hamilton Ave SB	1	SB	0	0	739	45	0	859
Hamilton Ave SB & W 9th St 2019 (TMC-040)	10							
Clinton Avenue	10	EB	0	0	55	0	0	
Clinton Avenue	10	WB	0	0	0	0	0	
Hamilton Ave SB	10		0	0	0	0	0	
Hamilton Ave SB	10	SB	0	192	547	25	0	819
Hamilton Ave SB & W 9th St 2019 (TMC-040)	11							
Clinton Avenue	11	EB	0	247	0	0	0	
Clinton Avenue	11		0	0	0	0	0	
Hamilton Ave	11	NB	0	0	1110	0	0	
Hamilton Ave	11		0	0	0	0	0	1357
Hamilton Ave SB & W 9th St 2019 (TMC-040)	111							
W 9th St	111	EB	0	0	0	0	0	
W 9th St	111	WB	0	0	0	0	0	
Hamilton Ave	111	NB	0	75	1282	0	0	
-	111	SB	0	0	0	0	0	1357
Hamilton Ave NB & W 9th St 2019 (TMC-041)	2							
W 9th St	2	EB	0	0	0	0	0	
W 9th St	2	WB	0	0	0	76	0	
Hamilton Ave	2	NB	0	0	1034	0	0	
Hamilton Ave	2	SB	0	0	0	0	0	1110

CBD Tolling
UE #1 - Traffic Flowmap
AM No-Action





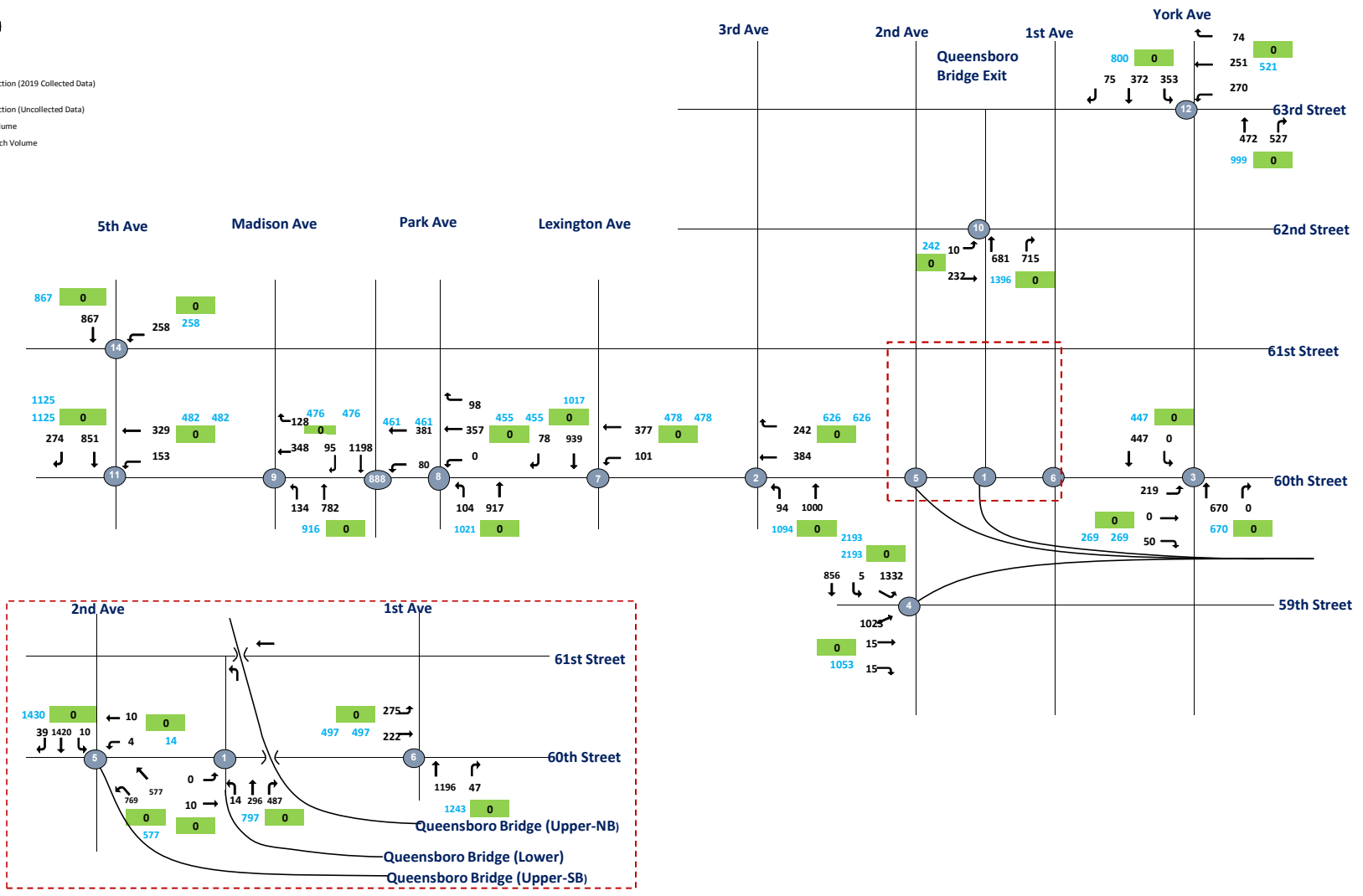

- Legend:**
- 1 - Intersection (2019 Collected Data)
 - 7 - Intersection (Uncollected Data)
 - 100 - ATR Volume
 - 100 - Approach Volume



CBD Tolling
UE #2 - Traffic Flowmap
AM No-Action



- Legend:**
-  - Intersection (2019 Collected Data)
 -  - Intersection (Uncollected Data)
 -  - ATR Volume
 -  - Approach Volume

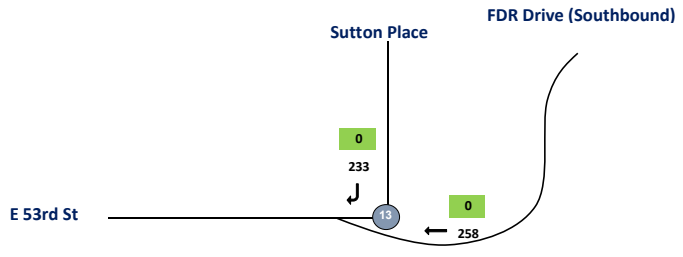

CBD Tolling
UE #3 - Traffic Flowmap
AM No-Action



- Legend:**
- 1 - Intersection (2019 Collected Data)
 - 7 - Intersection (Uncollected Data)
 - 100 - ATR Volume
 - 100 - Approach Volume

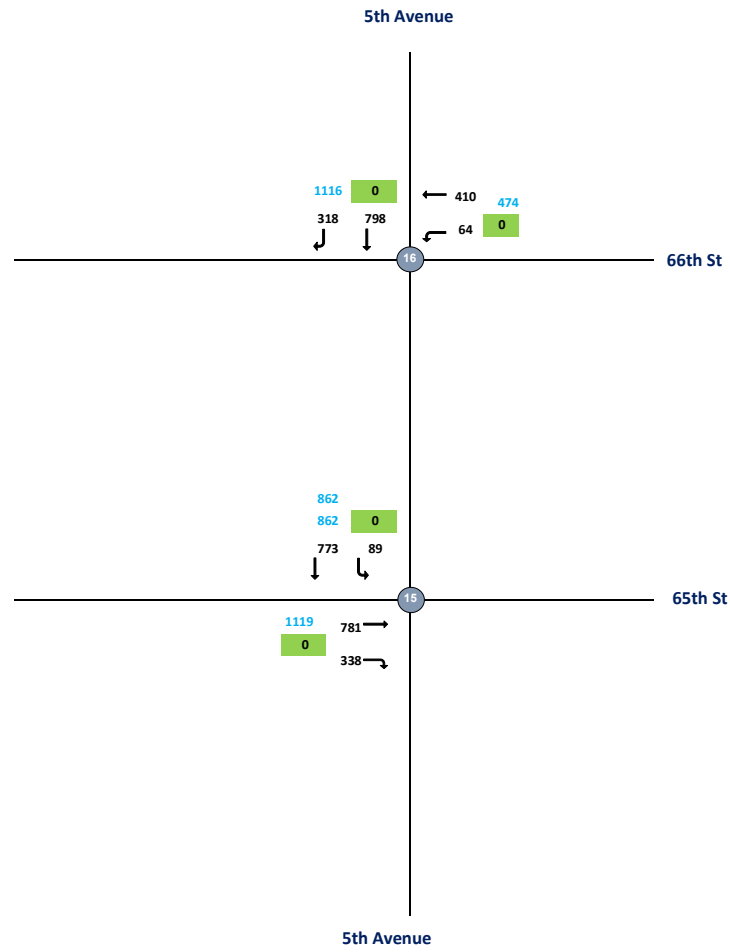

CBD Tolling
UE #3 - Traffic Flowmap
AM No-Action



- Legend:**
- Intersection (2019 Collected Data)
 - Intersection (Uncollected Data)
 - 100 - ATR Volume
 - 100 - Approach Volume

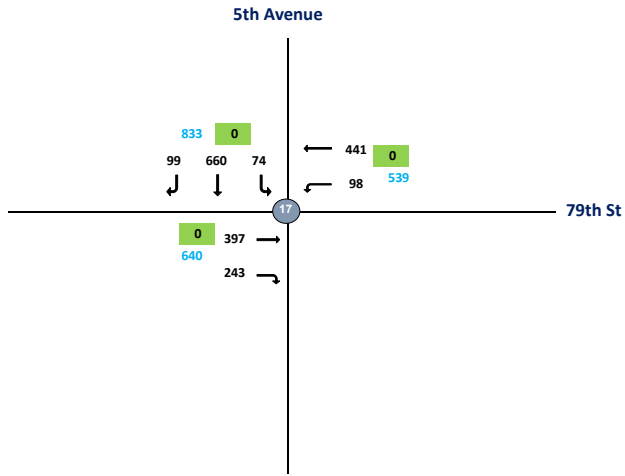

CBD Tolling
UE #4 - Traffic Flowmap
AM No-Action



- Legend:**
- Intersection (2019 Collected Data)
 - Intersection (Uncollected Data)
 - 100 - ATR Volume
 - 100 - Approach Volume

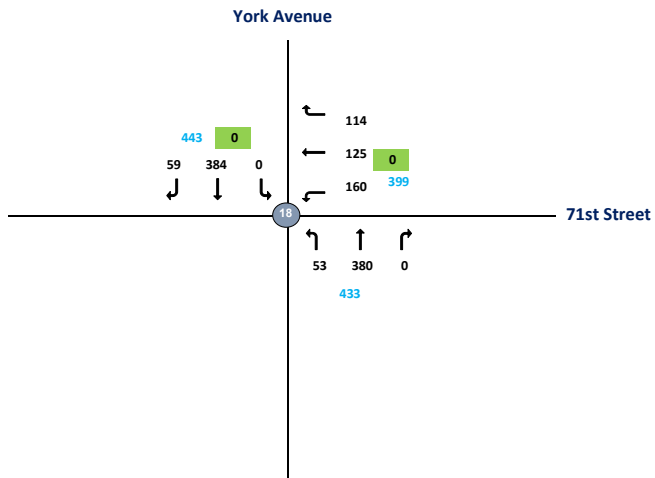

UE

8:00:00 AM

Intersection	Node	Approach	Total Vehicles						
			Inbound/Outbound						
			AM Peak Hour						
			L2	L	T	R	R2	Total	
60th Street & Queensboro Bridge Exit 2019 (TMC-022)	1								
60th Street	1	EB	0	0	10	0	0		
60th Street	1	WB	0	0	0	0	0		
Queensboro Bridge Exit	1	NB	0	11	226	371	0		
	1	SB	0	0	0	0	0		618
60th Street & 3rd Ave 2019 (TMC-023)	2								
60th Street	2	EB	0	0	0	0	0		
60th Street	2	WB	0	0	408	250	0		
3rd Ave	2	NB	0	68	713	0	0		
	2	SB	0	0	0	0	0		1439
60th St & York Ave 2019 (TMC-024)	3								
60th St	3	EB	0	90	0	50	0		
60th St	3	WB	0	0	0	0	0		
York Ave	3	NB	0	0	670	0	0		
York Ave	3	SB	0	0	318	0	0		1128
59th St & 2nd Ave 2019 (TMC-025)	4								
Queensboro Bridge Exit (SWB)	4								
59th St	4	EB	0	0	727	14	14		
	4	WB	0	0	0	0	0		
	4	NB	0	0	0	0	0		
2nd Ave	4	SB	885	4	811	0	0		2455
60th Street & 2nd Ave 2019 (TMC-026)	5	WB(bridge)							
Queensboro Bridge Exit (NWB)	5	NW	828	621	0	0	0		
60th St	5	EB	0	0	0	0	0		
60th St	5	WB	0	1	10	0	0		
	5	NB	0	0	0	0	0		
2nd Ave	5	SB	10	0	871	27	0		919
60th St & 1st Ave 2019 (TMC-027)	6								
60th Ave	6	EB	0	275	106	0	0		
	6	WB	0	0	0	0	0		
1st Ave	6	NB	0	0	859	34	0		
	6	SB	0	0	0	0	0		1274

60th St & Lexington Ave 2019 (TMC-028)	7							
	7	EB	0	0	0	0	0	
60th St	7	WB	0	101	375	0	0	
	7	NB	0	0	0	0	0	
Lexington Ave	7	SB	0	0	729	61	0	1266
60th St & Park Ave 2019 (TMC-029)	8							
	8	EB	0	0	0	0	0	
60th St	8	WB	0	0	357	79	0	
Park Ave	8	NB	0	86	751	0	0	
Park Ave	8	SB	0	0	0	0	0	1273
60th St & Park Ave 2019 (TMC-029)	888							
	888	EB	0	0	0	0	0	
60th St	888	WB	0	80	363	0	0	
Park Ave	888	NB	0	0	0	0	0	
Park Ave	888	SB	0	0	1166	92	0	1701
60th St & Madison Ave 2019 (TMC-030)	9							
	9	EB	0	0	0	0	0	
60th St	9	WB	0	0	346	109	0	
Madison Ave	9	NB	0	105	612	0	0	
	9	SB	0	0	0	0	0	1172
62nd St & Queensboror Bridge Exit 2019 (TMC-031)	10							
62nd St	10	EB	0	8	184	0	0	
	10	WB	0	0	0	0	0	
Queensboro Bridge Exit	10	NB	0	0	491	517	0	
	10	SB	0	0	0	0	0	1200
60th St & 5th Ave 2019 (TMC-032)	11							
	11	EB	0	0	0	0	0	
60th St	11	WB	0	150	301	0	0	
	11	NB	0	0	0	0	0	
5th Ave	11	SB	0	0	652	210	0	1313

63rd St & York Ave 2019 (TMC-033)	12							
	12	EB	0	0	0	0	0	
63rd St	12	WB	0	216	212	65	0	
York Ave	12	NB	0	0	414	431	0	
York Ave	12	SB	0	332	342	74	0	2086
53rd St & FDR Drive 2019 (TMC-034)	13							
	13	EB	0	0	0	0	0	
53rd St	13	SW	0	0	0	233	0	
	13	NB	0	0	0	0	0	
FDR Drive	13	SB	0	0	0	221	0	454
61st St & 5th Ave 2019 (TMC-035)	14							
	14	EB	0	0	0	0	0	
61st St	14	WB	0	205	0	0	0	
	14	NB	0	0	0	0	0	
5th Ave	14	SB	0	0	657	0	0	862
65th St & 5th Ave 2019 (TMC-036)	15							
65th St	15	EB	0	0	755	327	0	
	15	WB	0	0	0	0	0	
	15	NB	0	0	0	0	0	
5th Ave	15	SB	0	78	681	0	0	1841
66th St & 5th Ave 2019 (TMC-037)	16							
	16	EB	0	0	0	0	0	
66th St	16	WB	0	57	363	0	0	
	16	NB	0	0	0	0	0	
5th Ave	16	SB	0	0	702	298	0	1420
79th St & 5th Ave 2019 (TMC-038)	17							
79th St	17	EB	0	0	375	229	0	
79th St	17	WB	0	90	390	0	0	
	17	NB	0	0	0	0	0	
5th Ave	17	SB	0	67	601	87	0	1839
71st St & York Ave 2019 (TMC-039)	18							
	18	EB	0	0	0	0	0	
71st St	18	WB	0	157	124	104	0	
York Ave	18	NB	0	48	307	0	0	
York Ave	18	SB	0	0	328	52	0	1120

CBD Tolling
UE #1 - Traffic Flowmap
MD No-Action





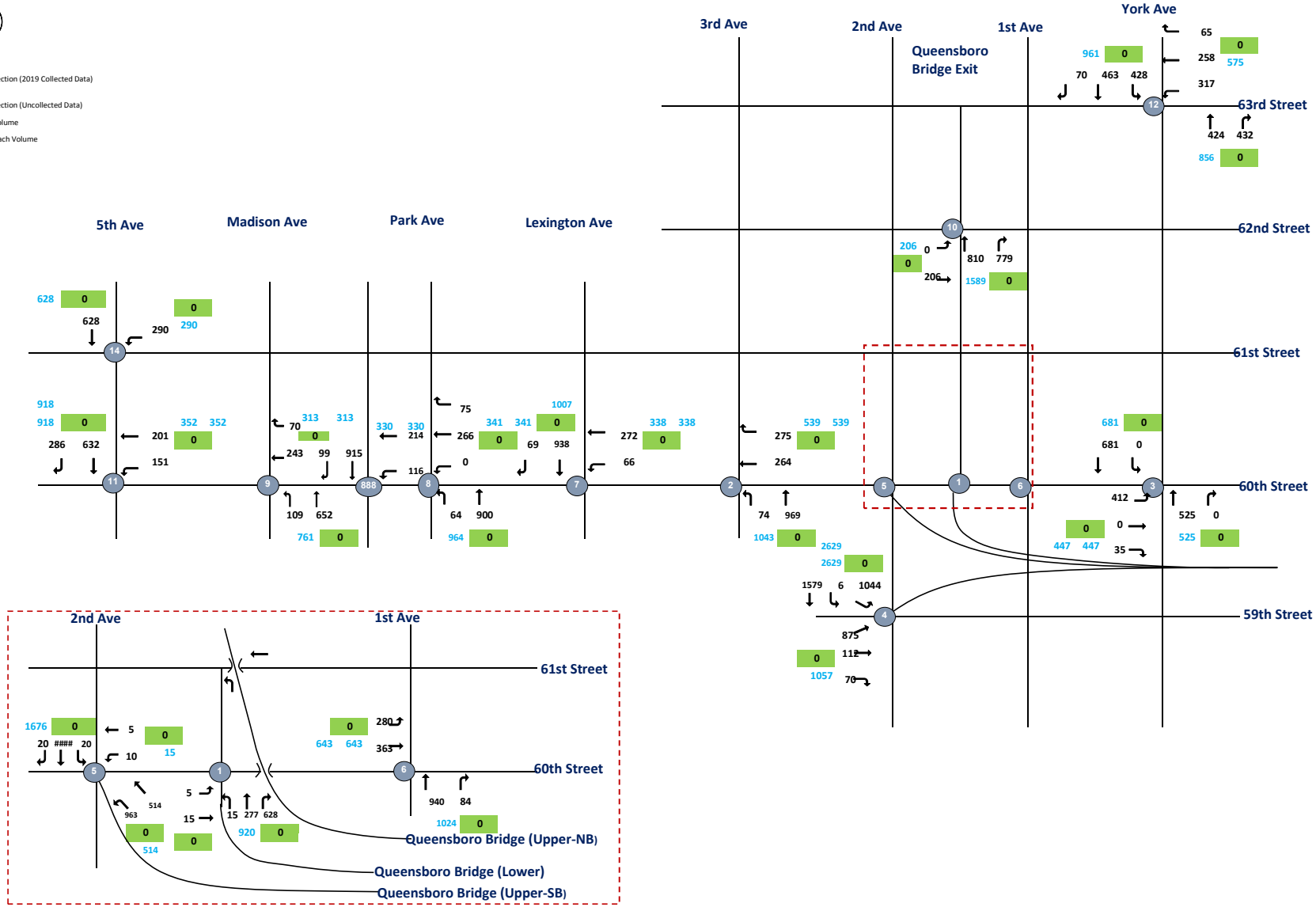

- Legend:**
- 1 - Intersection (2019 Collected Data)
 - 7 - Intersection (Uncollected Data)
 - 100 - ATR Volume
 - 100 - Approach Volume



CBD Tolling
UE #2 - Traffic Flowmap
MD No-Action



- Legend:**
-  - Intersection (2019 Collected Data)
 -  - Intersection (Uncollected Data)
 -  - ATR Volume
 -  - Approach Volume

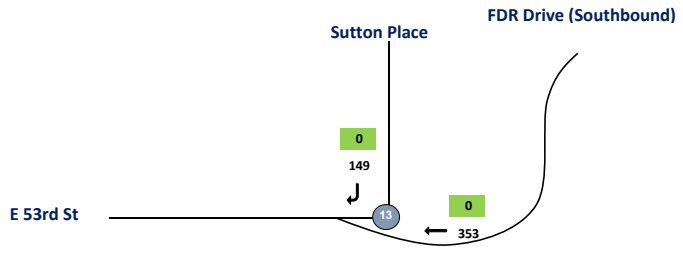

CBD Tolling
UE #3 - Traffic Flowmap
MD No-Action



- Legend:**
- 1 - Intersection (2019 Collected Data)
 - 7 - Intersection (Uncollected Data)
 - 100 - ATR Volume
 - 100 - Approach Volume

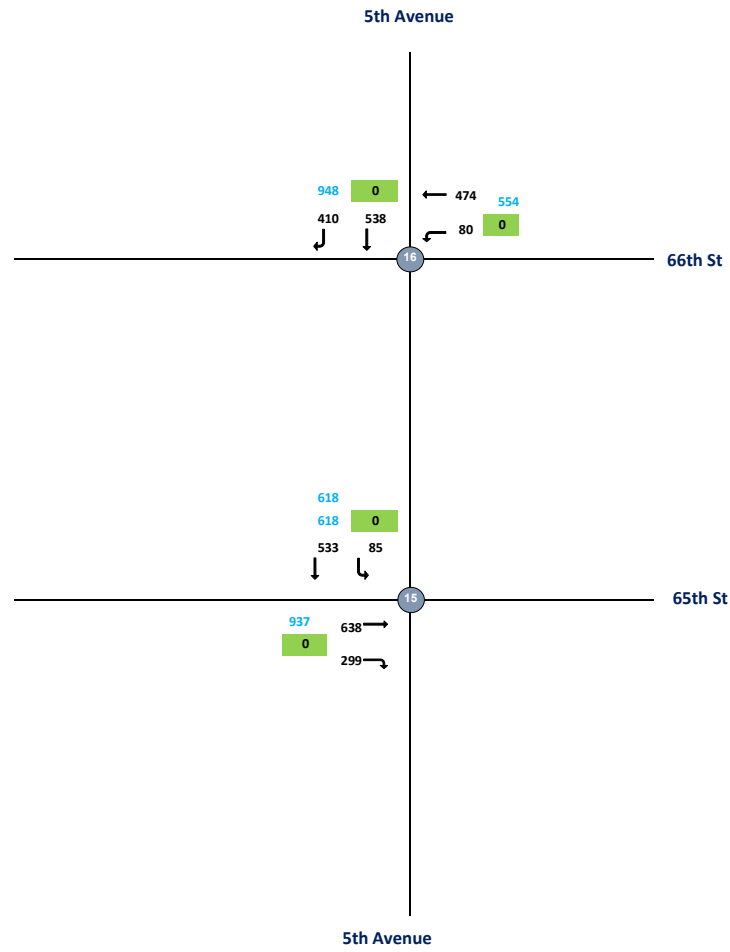

CBD Tolling
UE #3 - Traffic Flowmap
MD No-Action



- Legend:**
- Intersection (2019 Collected Data)
 - Intersection (Uncollected Data)
 - 100 - ATR Volume
 - 100 - Approach Volume

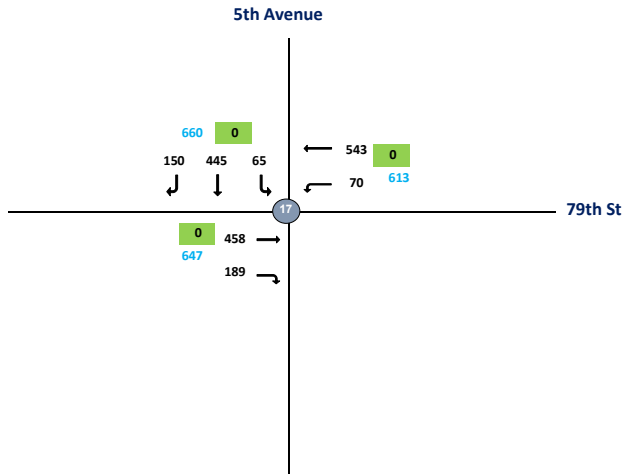

CBD Tolling
UE #4 - Traffic Flowmap
MD No-Action



- Legend:**
- Intersection (2019 Collected Data)
 - Intersection (Uncollected Data)
 - 100 - ATR Volume
 - 100 - Approach Volume

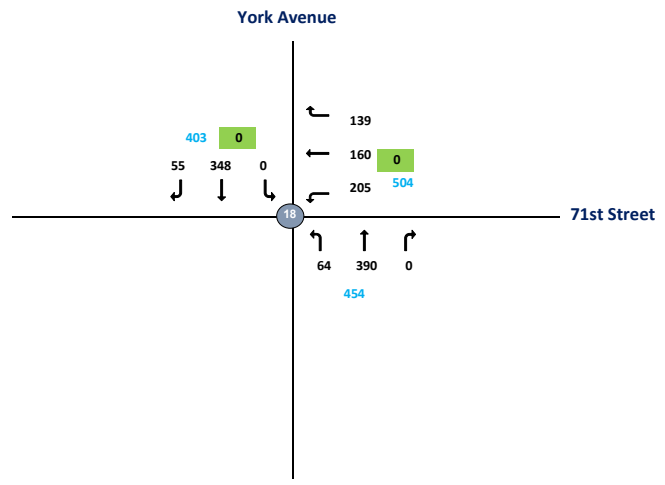

UE

1:00:00 MD

Intersection	Node	Approach	Total Vehicles						
			Inbound/Outbound						
			MD Peak Hour						
			L2	L	T	R	R2	Total	
60th Street & Queensboro Bridge Exit 2019 (TMC-022)	1								
60th Street	1	EB	0	5	15	0	0		
60th Street	1	WB	0	0	0	0	0		
Queensboro Bridge Exit	1	NB	0	15	277	628	0		
	1	SB	0	0	0	0	0		940
60th Street & 3rd Ave 2019 (TMC-023)	2								
60th Street	2	EB	0	0	0	0	0		
60th Street	2	WB	0	0	264	275	0		
3rd Ave	2	NB	0	74	969	0	0		
	2	SB	0	0	0	0	0		1582
60th St & York Ave 2019 (TMC-024)	3								
60th St	3	EB	0	412	0	35	0		
60th St	3	WB	0	0	0	0	0		
York Ave	3	NB	0	0	525	0	0		
York Ave	3	SB	0	0	681	0	0		1653
59th St & 2nd Ave 2019 (TMC-025)	4								
Queensboro Bridge Exit (SWB)	4								
59th St	4	EB	0	0	875	112	70		
	4	WB	0	0	0	0	0		
	4	NB	0	0	0	0	0		
2nd Ave	4	SB	1044	6	1579	0	0		3686
60th Street & 2nd Ave 2019 (TMC-026)	5	WB(bridge)							
Queensboro Bridge Exit (NWB)	5	NW	963	514	0	0	0		
60th St	5	EB	0	0	0	0	0		
60th St	5	WB	0	10	5	0	0		
	5	NB	0	0	0	0	0		
2nd Ave	5	SB	20	0	1656	20	0		1711
60th St & 1st Ave 2019 (TMC-027)	6								
60th Ave	6	EB	0	280	363	0	0		
	6	WB	0	0	0	0	0		
1st Ave	6	NB	0	0	940	84	0		
	6	SB	0	0	0	0	0		1667

60th St & Lexington Ave 2019 (TMC-028)	7							
	7	EB	0	0	0	0	0	
60th St	7	WB	0	66	272	0	0	
	7	NB	0	0	0	0	0	
Lexington Ave	7	SB	0	0	938	69	0	1345
60th St & Park Ave 2019 (TMC-029)	8							
	8	EB	0	0	0	0	0	
60th St	8	WB	0	0	266	75	0	
Park Ave	8	NB	0	64	900	0	0	
Park Ave	8	SB	0	0	0	0	0	1305
60th St & Park Ave 2019 (TMC-029)	888							
	888	EB	0	0	0	0	0	
60th St	888	WB	0	116	214	0	0	
Park Ave	888	NB	0	0	0	0	0	
Park Ave	888	SB	0	0	915	99	0	1344
60th St & Madison Ave 2019 (TMC-030)	9							
	9	EB	0	0	0	0	0	
60th St	9	WB	0	0	243	70	0	
Madison Ave	9	NB	0	109	652	0	0	
	9	SB	0	0	0	0	0	1074
62nd St & Queensboror Bridge Exit 2019 (TMC-031)	10							
62nd St	10	EB	0	0	206	0	0	
	10	WB	0	0	0	0	0	
Queensboro Bridge Exit	10	NB	0	0	810	779	0	
	10	SB	0	0	0	0	0	1795
60th St & 5th Ave 2019 (TMC-032)	11							
	11	EB	0	0	0	0	0	
60th St	11	WB	0	151	201	0	0	
	11	NB	0	0	0	0	0	
5th Ave	11	SB	0	0	632	286	0	1270

63rd St & York Ave 2019 (TMC-033)	12							
	12	EB	0	0	0	0	0	
63rd St	12	WB	0	317	258	65	0	
York Ave	12	NB	0	0	424	432	0	
York Ave	12	SB	0	428	463	70	0	2457
53rd St & FDR Drive 2019 (TMC-034)	13							
	13	EB	0	0	0	0	0	
53rd St	13	SW	0	0	0	353	0	
	13	NB	0	0	0	0	0	
FDR Drive	13	SB	0	0	0	149	0	502
61st St & 5th Ave 2019 (TMC-035)	14							
	14	EB	0	0	0	0	0	
61st St	14	WB	0	290	0	0	0	
	14	NB	0	0	0	0	0	
5th Ave	14	SB	0	0	628	0	0	918
65th St & 5th Ave 2019 (TMC-036)	15							
65th St	15	EB	0	0	638	299	0	
	15	WB	0	0	0	0	0	
	15	NB	0	0	0	0	0	
5th Ave	15	SB	0	85	533	0	0	1555
66th St & 5th Ave 2019 (TMC-037)	16							
	16	EB	0	0	0	0	0	
66th St	16	WB	0	80	474	0	0	
	16	NB	0	0	0	0	0	
5th Ave	16	SB	0	0	538	410	0	1502
79th St & 5th Ave 2019 (TMC-038)	17							
79th St	17	EB	0	0	458	189	0	
79th St	17	WB	0	70	543	0	0	
	17	NB	0	0	0	0	0	
5th Ave	17	SB	0	65	445	150	0	1920
71st St & York Ave 2019 (TMC-039)	18							
	18	EB	0	0	0	0	0	
71st St	18	WB	0	205	160	139	0	
York Ave	18	NB	0	64	390	0	0	
York Ave	18	SB	0	0	348	55	0	1361

CBD Tolling
UE #1 - Traffic Flowmap
PM No-Action



- Legend:**
- 1 - Intersection (2019 Collected Data)
 - 7 - Intersection (Uncollected Data)
 - 100 - ATR Volume
 - 100 - Approach Volume

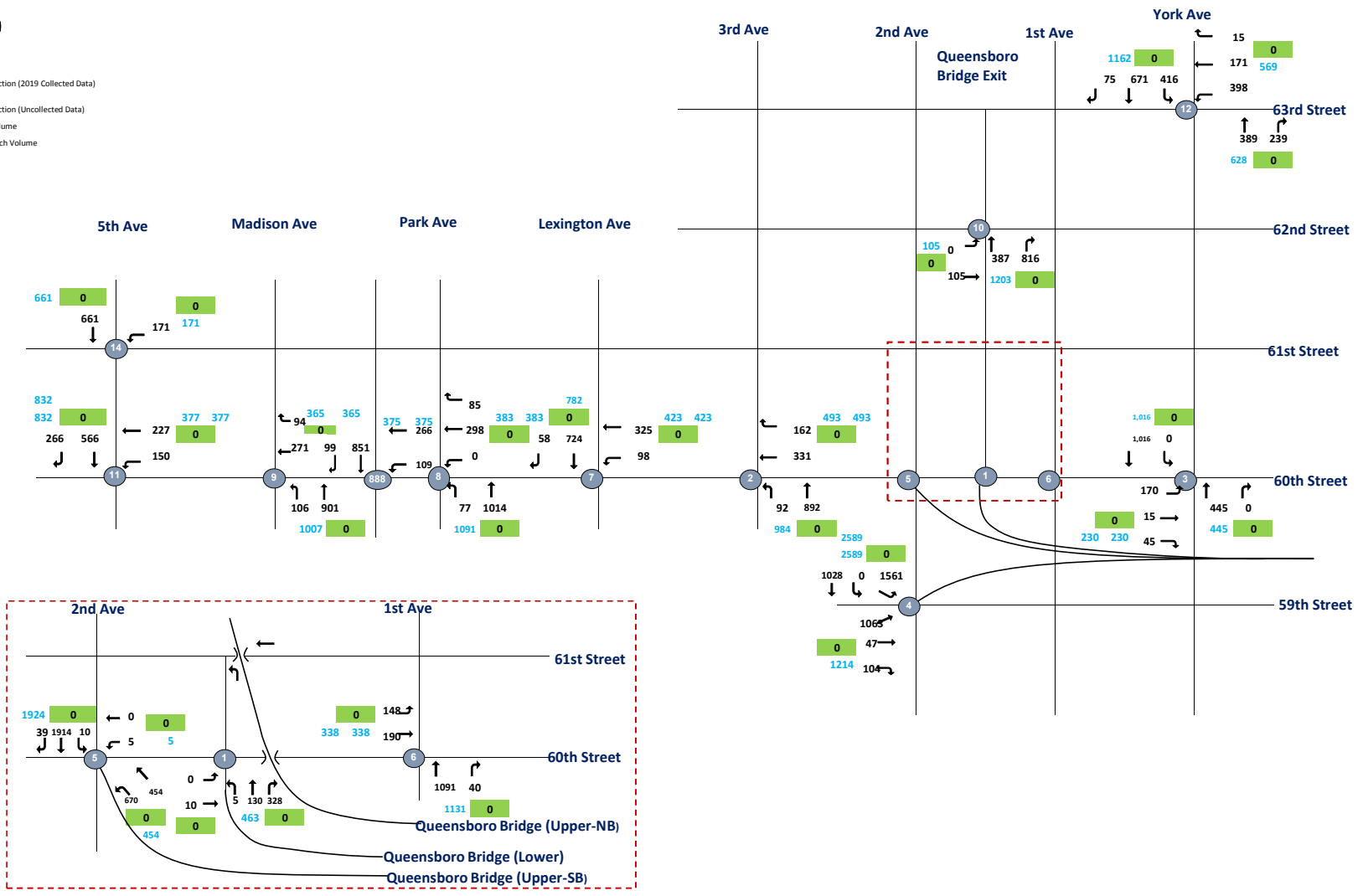

CBD Tolling
UE #2 - Traffic Flowmap
PM No-Action



- Legend:**
- Intersection (2019 Collected Data)
 - Intersection (Uncollected Data)
 - 100 - ATR Volume
 - 100 - Approach Volume

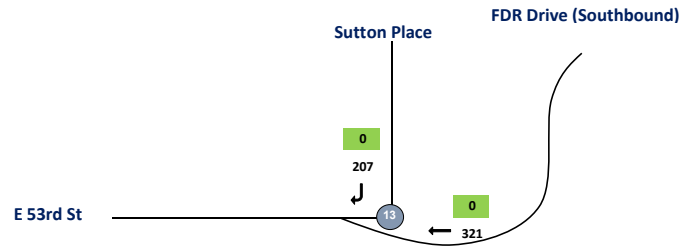

CBD Tolling
UE #3 - Traffic Flowmap
PM No-Action



- Legend:**
- 1 - Intersection (2019 Collected Data)
 - 7 - Intersection (Uncollected Data)
 - 100 - ATR Volume
 - 100 - Approach Volume

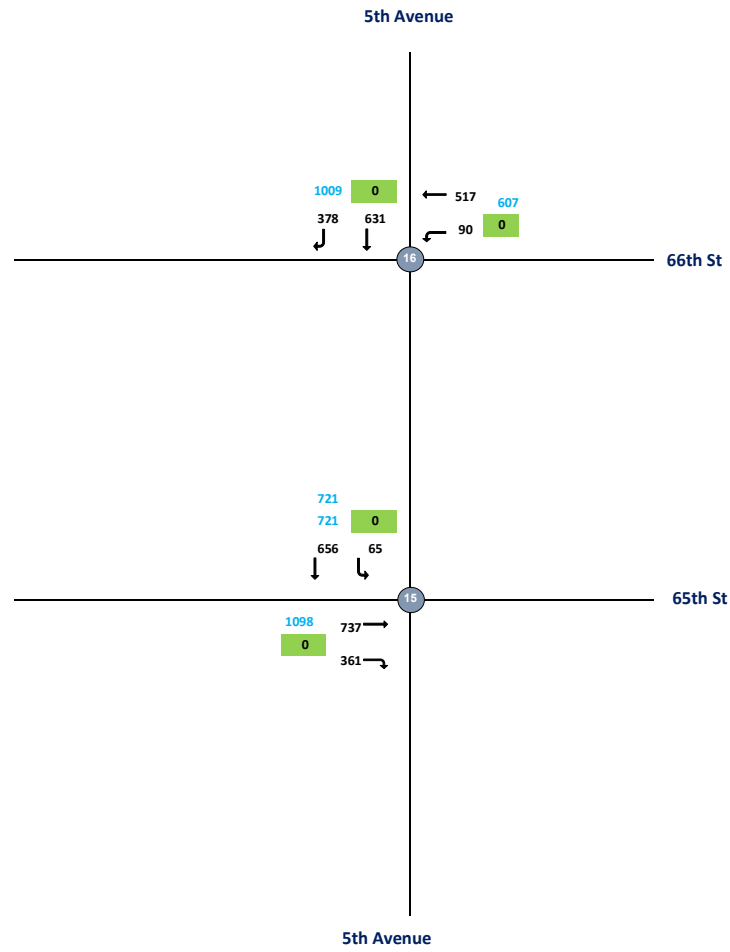

CBD Tolling
UE #3 - Traffic Flowmap
PM No-Action



- Legend:**
- Intersection (2019 Collected Data)
 - Intersection (Uncollected Data)
 - 100 - ATR Volume
 - 100 - Approach Volume

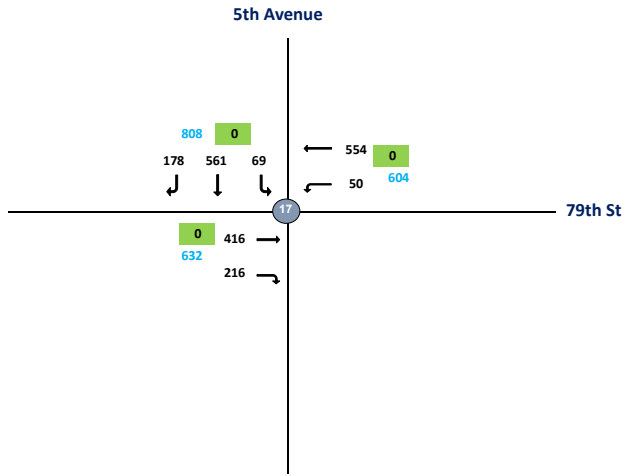

CBD Tolling
UE #4 - Traffic Flowmap
PM No-Action



- Legend:**
- Intersection (2019 Collected Data)
 - Intersection (Uncollected Data)
 - 100 - ATR Volume
 - 100 - Approach Volume

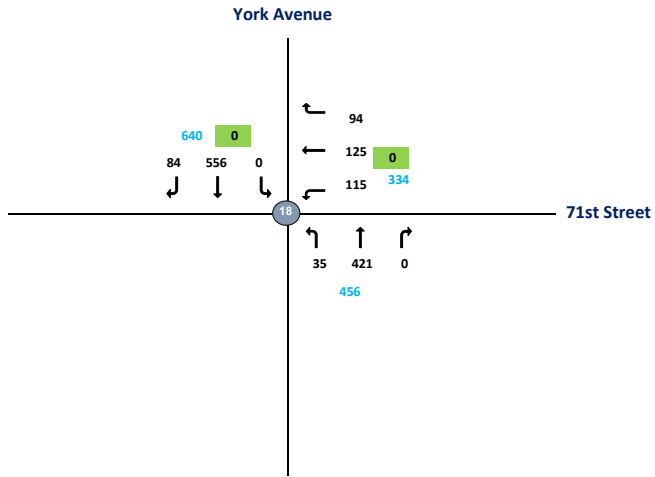

UE

5:00:00 PM

Intersection	Node	Approach	Total Vehicles					
			Inbound/Outbound					Total
			L2	L	T	R	R2	
60th Street & Queensboro Bridge Exit 2019 (TMC-022)	1							
60th Street	1	EB	0	0	5	0	0	
60th Street	1	WB	0	0	0	0	0	
Queensboro Bridge Exit	1	NB	0	2	67	169	0	
	1	SB	0	0	0	0	0	243
60th Street & 3rd Ave 2019 (TMC-023)	2							
60th Street	2	EB	0	0	0	0	0	
60th Street	2	WB	0	0	199	88	0	
3rd Ave	2	NB	0	61	591	0	0	
	2	SB	0	0	0	0	0	939
60th St & York Ave 2019 (TMC-024)	3							
60th St	3	EB	0	22	15	45	0	
60th St	3	WB	0	0	0	0	0	
York Ave	3	NB	0	0	445	0	0	
York Ave	3	SB	0	0	624	0	0	1151
59th St & 2nd Ave 2019 (TMC-025)	4							
Queensboro Bridge Exit (SWB)	4							
59th St	4	EB	0	0	121	17	88	
	4	WB	0	0	0	0	0	
	4	NB	0	0	0	0	0	
2nd Ave	4	SB	110	0	705	0	0	1041
60th Street & 2nd Ave 2019 (TMC-026)	5	WB(bridge)						
Queensboro Bridge Exit (NWB)	5	NW	397	269	0	0	0	
60th St	5	EB	0	0	0	0	0	
60th St	5	WB	0	2	0	0	0	
	5	NB	0	0	0	0	0	
2nd Ave	5	SB	7	0	416	18	0	443
60th St & 1st Ave 2019 (TMC-027)	6							
60th Ave	6	EB	0	116	58	0	0	
	6	WB	0	0	0	0	0	
1st Ave	6	NB	0	0	649	24	0	
	6	SB	0	0	0	0	0	847

60th St & Lexington Ave 2019 (TMC-028)	7							
	7	EB	0	0	0	0	0	
60th St	7	WB	0	39	221	0	0	
	7	NB	0	0	0	0	0	
Lexington Ave	7	SB	0	0	418	33	0	711
60th St & Park Ave 2019 (TMC-029)	8							
	8	EB	0	0	0	0	0	
60th St	8	WB	0	0	169	85	0	
Park Ave	8	NB	0	54	716	0	0	
Park Ave	8	SB	0	0	0	0	0	1024
60th St & Park Ave 2019 (TMC-029)	888							
	888	EB	0	0	0	0	0	
60th St	888	WB	0	62	161	0	0	
Park Ave	888	NB	0	0	0	0	0	
Park Ave	888	SB	0	0	790	92	0	1105
60th St & Madison Ave 2019 (TMC-030)	9							
	9	EB	0	0	0	0	0	
60th St	9	WB	0	0	230	23	0	
Madison Ave	9	NB	0	79	675	0	0	
	9	SB	0	0	0	0	0	1007
62nd St & Queensboror Bridge Exit 2019 (TMC-031)	10							
62nd St	10	EB	0	0	57	0	0	
	10	WB	0	0	0	0	0	
Queensboro Bridge Exit	10	NB	0	0	197	418	0	
	10	SB	0	0	0	0	0	672
60th St & 5th Ave 2019 (TMC-032)	11							
	11	EB	0	0	0	0	0	
60th St	11	WB	0	124	185	0	0	
	11	NB	0	0	0	0	0	
5th Ave	11	SB	0	0	352	166	0	827

63rd St & York Ave 2019 (TMC-033)	12							
	12	EB	0	0	0	0	0	
63rd St	12	WB	0	297	140	13	0	
York Ave	12	NB	0	0	264	127	0	
York Ave	12	SB	0	354	600	74	0	1869
53rd St & FDR Drive 2019 (TMC-034)	13							
	13	EB	0	0	0	0	0	
53rd St	13	SW	0	0	0	266	0	
	13	NB	0	0	0	0	0	
FDR Drive	13	SB	0	0	0	178	0	444
61st St & 5th Ave 2019 (TMC-035)	14							
	14	EB	0	0	0	0	0	
61st St	14	WB	0	9	0	0	0	
	14	NB	0	0	0	0	0	
5th Ave	14	SB	0	0	509	0	0	518
65th St & 5th Ave 2019 (TMC-036)	15							
65th St	15	EB	0	0	696	341	0	
	15	WB	0	0	0	0	0	
	15	NB	0	0	0	0	0	
5th Ave	15	SB	0	60	604	0	0	1701
66th St & 5th Ave 2019 (TMC-037)	16							
	16	EB	0	0	0	0	0	
66th St	16	WB	0	78	448	0	0	
	16	NB	0	0	0	0	0	
5th Ave	16	SB	0	0	586	367	0	1479
79th St & 5th Ave 2019 (TMC-038)	17							
79th St	17	EB	0	0	373	194	0	
79th St	17	WB	0	45	485	0	0	
	17	NB	0	0	0	0	0	
5th Ave	17	SB	0	67	546	169	0	1879
71st St & York Ave 2019 (TMC-039)	18							
	18	EB	0	0	0	0	0	
71st St	18	WB	0	110	124	81	0	
York Ave	18	NB	0	29	294	0	0	
York Ave	18	SB	0	0	469	76	0	1183

CBD Tolling
UE #1 - Traffic Flowmap
LN No-Action





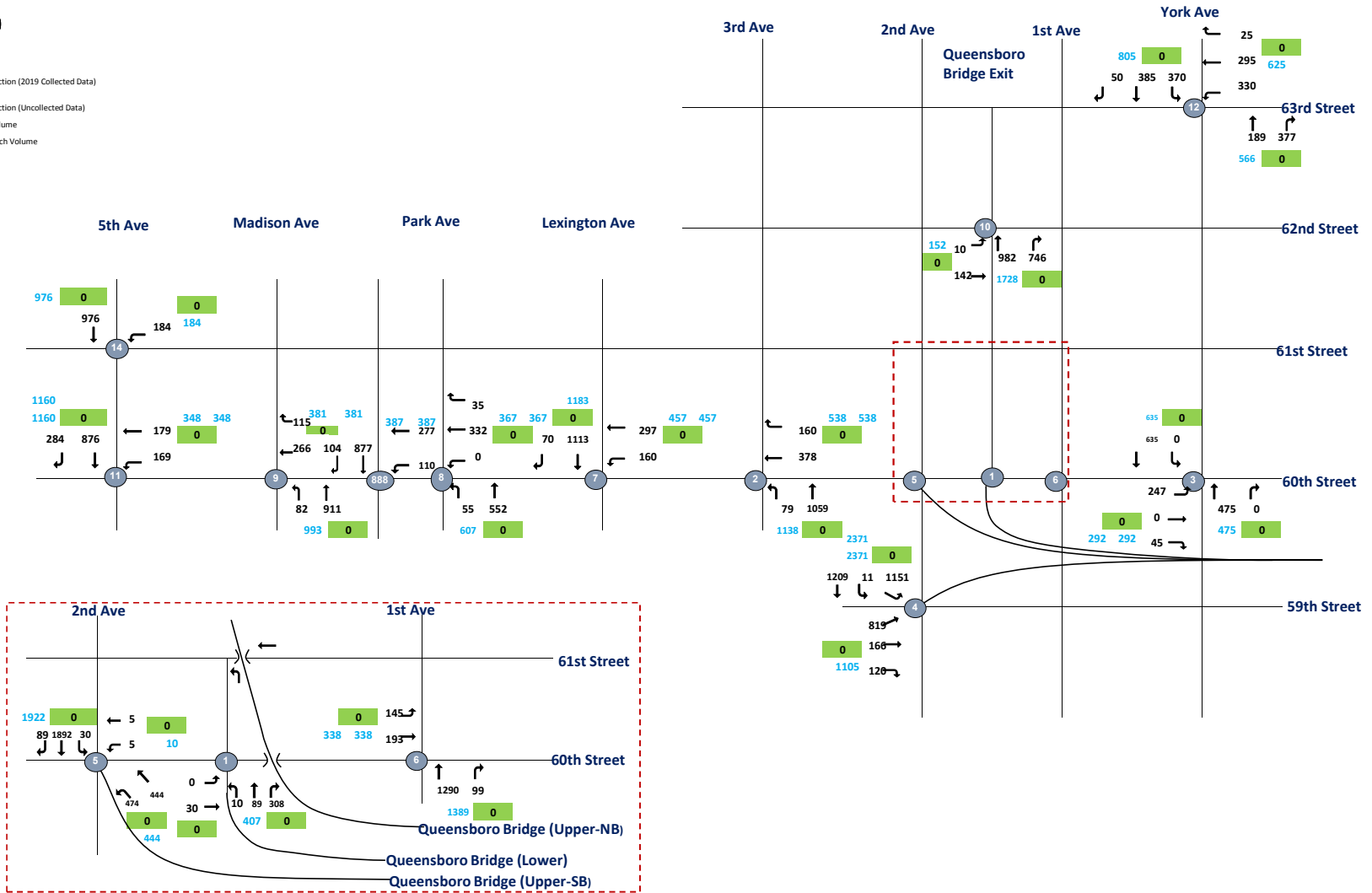

- Legend:**
- 1 - Intersection (2019 Collected Data)
 - 7 - Intersection (Uncollected Data)
 - 100 - ATR Volume
 - 100 - Approach Volume



CBD Tolling
UE #2 - Traffic Flowmap
LN No-Action



- Legend:**
-  - Intersection (2019 Collected Data)
 -  - Intersection (Uncollected Data)
 -  - ATR Volume
 -  - Approach Volume

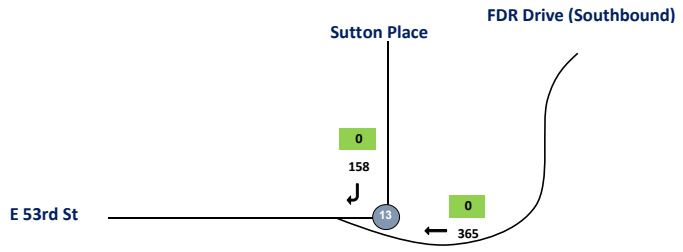

CBD Tolling
UE #3 - Traffic Flowmap
LN No-Action



- Legend:**
- 1 - Intersection (2019 Collected Data)
 - 7 - Intersection (Uncollected Data)
 - 100 - ATR Volume
 - 100 - Approach Volume

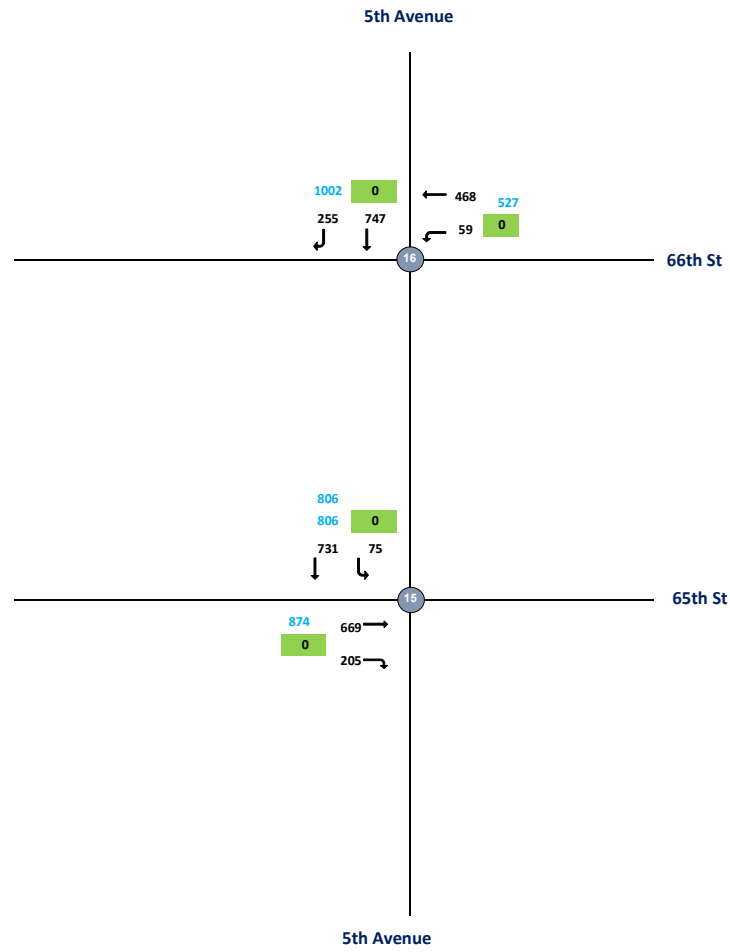

CBD Tolling
UE #3 - Traffic Flowmap
LN No-Action



- Legend:**
- Intersection (2019 Collected Data)
 - Intersection (Uncollected Data)
 - 100 - ATR Volume
 - 100 - Approach Volume

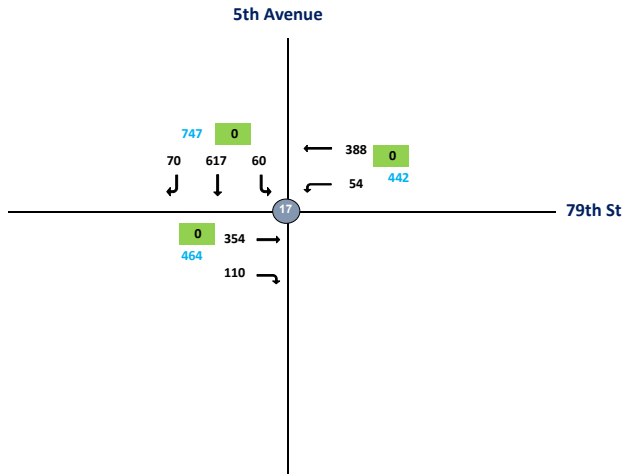

CBD Tolling
UE #4 - Traffic Flowmap
LN No-Action



- Legend:**
- Intersection (2019 Collected Data)
 - Intersection (Uncollected Data)
 - 100 - ATR Volume
 - 100 - Approach Volume

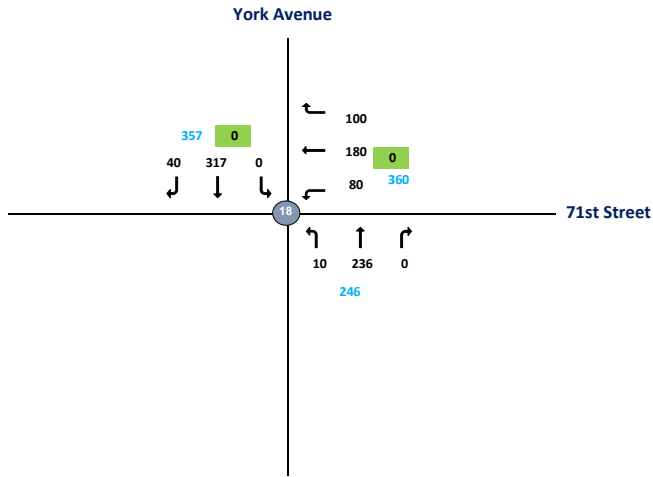

UE

9:00:00 PM

Intersection	Node	Approach	Total Vehicles						
			Inbound/Outbound						
			LN Peak Hour						
			L2	L	T	R	R2	Total	
60th Street & Queensboro Bridge Exit 2019 (TMC-022)	1								
60th Street	1	EB	0	0	30	0	0		
60th Street	1	WB	0	0	0	0	0		
Queensboro Bridge Exit	1	NB	0	10	89	308	0		
	1	SB	0	0	0	0	0		437
60th Street & 3rd Ave 2019 (TMC-023)	2								
60th Street	2	EB	0	0	0	0	0		
60th Street	2	WB	0	0	378	160	0		
3rd Ave	2	NB	0	79	1059	0	0		
	2	SB	0	0	0	0	0		1676
60th St & York Ave 2019 (TMC-024)	3								
60th St	3	EB	0	247	0	45	0		
60th St	3	WB	0	0	0	0	0		
York Ave	3	NB	0	0	475	0	0		
York Ave	3	SB	0	0	635	0	0		1402
59th St & 2nd Ave 2019 (TMC-025)	4								
Queensboro Bridge Exit (SWB)	4								
59th St	4	EB	0	0	819	166	120		
	4	WB	0	0	0	0	0		
	4	NB	0	0	0	0	0		
2nd Ave	4	SB	1151	11	1209	0	0		3476
60th Street & 2nd Ave 2019 (TMC-026)	5	WB(bridge)							
Queensboro Bridge Exit (NWB)	5	NW	474	444	0	0	0		
60th St	5	EB	0	0	0	0	0		
60th St	5	WB	0	5	5	0	0		
	5	NB	0	0	0	0	0		
2nd Ave	5	SB	30	0	1892	89	0		2021
60th St & 1st Ave 2019 (TMC-027)	6								
60th Ave	6	EB	0	145	193	0	0		
	6	WB	0	0	0	0	0		
1st Ave	6	NB	0	0	1290	99	0		
	6	SB	0	0	0	0	0		1727

60th St & Lexington Ave 2019 (TMC-028)	7							
	7	EB	0	0	0	0	0	
60th St	7	WB	0	160	297	0	0	
	7	NB	0	0	0	0	0	
Lexington Ave	7	SB	0	0	1113	70	0	1640
60th St & Park Ave 2019 (TMC-029)	8							
	8	EB	0	0	0	0	0	
60th St	8	WB	0	0	332	35	0	
Park Ave	8	NB	0	55	552	0	0	
Park Ave	8	SB	0	0	0	0	0	974
60th St & Park Ave 2019 (TMC-029)	888							
	888	EB	0	0	0	0	0	
60th St	888	WB	0	110	277	0	0	
Park Ave	888	NB	0	0	0	0	0	
Park Ave	888	SB	0	0	877	104	0	1368
60th St & Madison Ave 2019 (TMC-030)	9							
	9	EB	0	0	0	0	0	
60th St	9	WB	0	0	266	115	0	
Madison Ave	9	NB	0	82	911	0	0	
	9	SB	0	0	0	0	0	1374
62nd St & Queensboror Bridge Exit 2019 (TMC-031)	10							
62nd St	10	EB	0	10	142	0	0	
	10	WB	0	0	0	0	0	
Queensboro Bridge Exit	10	NB	0	0	982	746	0	
	10	SB	0	0	0	0	0	1880
60th St & 5th Ave 2019 (TMC-032)	11							
	11	EB	0	0	0	0	0	
60th St	11	WB	0	169	179	0	0	
	11	NB	0	0	0	0	0	
5th Ave	11	SB	0	0	876	284	0	1508

63rd St & York Ave 2019 (TMC-033)	12							
	12	EB	0	0	0	0	0	
63rd St	12	WB	0	330	295	25	0	
York Ave	12	NB	0	0	189	377	0	
York Ave	12	SB	0	370	385	50	0	2021
53rd St & FDR Drive 2019 (TMC-034)	13							
	13	EB	0	0	0	0	0	
53rd St	13	SW	0	0	0	365	0	
	13	NB	0	0	0	0	0	
FDR Drive	13	SB	0	0	0	158	0	523
61st St & 5th Ave 2019 (TMC-035)	14							
	14	EB	0	0	0	0	0	
61st St	14	WB	0	184	0	0	0	
	14	NB	0	0	0	0	0	
5th Ave	14	SB	0	0	976	0	0	1160
65th St & 5th Ave 2019 (TMC-036)	15							
65th St	15	EB	0	0	669	205	0	
	15	WB	0	0	0	0	0	
	15	NB	0	0	0	0	0	
5th Ave	15	SB	0	75	731	0	0	1680
66th St & 5th Ave 2019 (TMC-037)	16							
	16	EB	0	0	0	0	0	
66th St	16	WB	0	59	468	0	0	
	16	NB	0	0	0	0	0	
5th Ave	16	SB	0	0	747	255	0	1529
79th St & 5th Ave 2019 (TMC-038)	17							
79th St	17	EB	0	0	354	110	0	
79th St	17	WB	0	54	388	0	0	
	17	NB	0	0	0	0	0	
5th Ave	17	SB	0	60	617	70	0	1653
71st St & York Ave 2019 (TMC-039)	18							
	18	EB	0	0	0	0	0	
71st St	18	WB	0	80	180	100	0	
York Ave	18	NB	0	10	236	0	0	
York Ave	18	SB	0	0	317	40	0	963

CBD Tolling
UW #1 - Traffic Flowmap
AM No-Action



- Legend:**
- 1 - Intersection (2019 Collected Data)
 - 7 - Intersection (Uncollected Data)
 - 100 - ATR Volume
 - 100 - Approach Volume

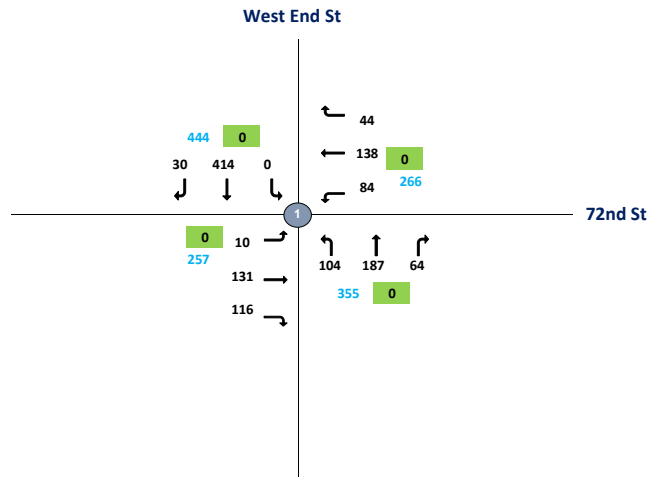

CBD Tolling
UW #2 - Traffic Flowmap
AM No-Action



- Legend:**
- - Intersection (2019 Collected Data)
 - - Intersection (Uncollected Data)
 - 100 - ATR Volume
 - 100 - Approach Volume

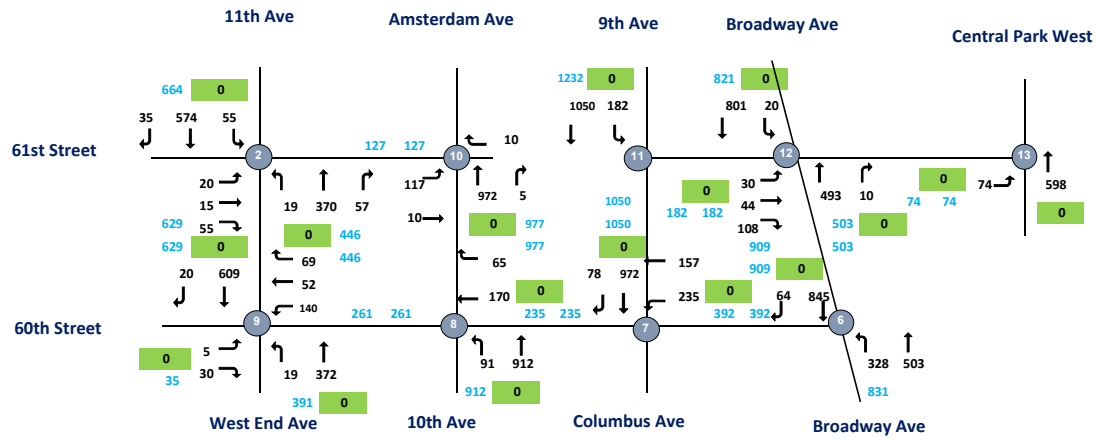

CBD Tolling
UW #3 - Traffic Flowmap
AM No-Action



- Legend:**
- 1 - Intersection (2019 Collected Data)
 - 7 - Intersection (Uncollected Data)
 - 100 - ATR Volume
 - 100 - Approach Volume

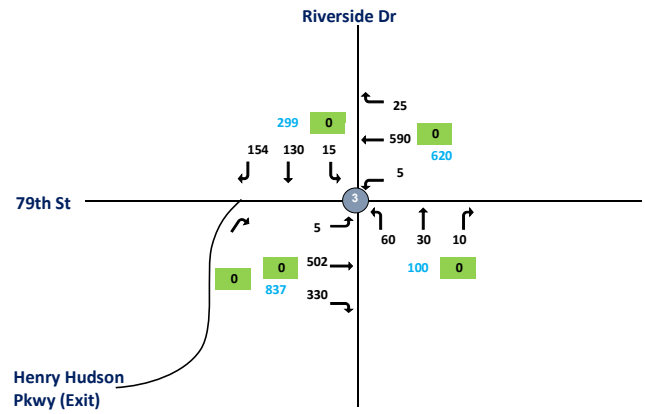

CBD Tolling
UW #4 - Traffic Flowmap
AM No-Action



- Legend:**
- 1 - Intersection (2019 Collected Data)
 - 7 - Intersection (Uncollected Data)
 - 100 - ATR Volume
 - 100 - Approach Volume

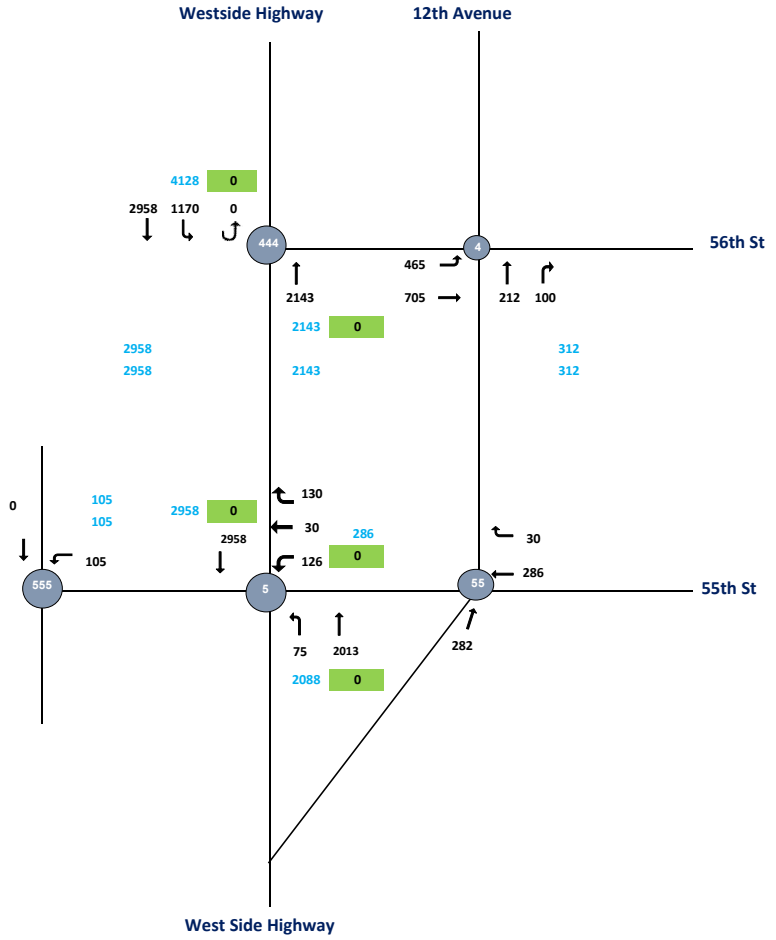

CBD Tolling
UW #5 - Traffic Flowmap
AM No-Action



- Legend:**
- Intersection (2019 Collected Data)
 - Intersection (Uncollected Data)
 - ATR Volume
 - Approach Volume

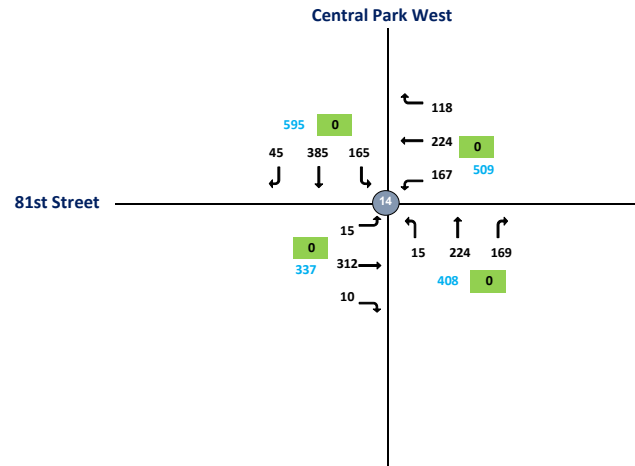

CBD Tolling
UW #6 - Traffic Flowmap
AM No-Action



- Legend:**
- 1 - Intersection (2019 Collected Data)
 - 7 - Intersection (Uncollected Data)
 - 100 - ATR Volume
 - 100 - Approach Volume

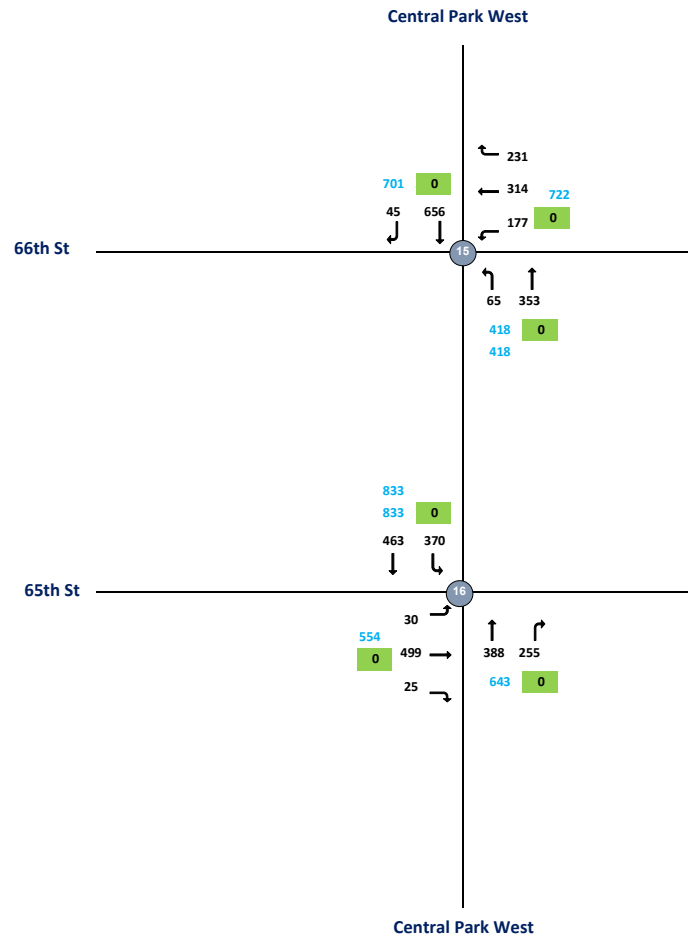

Intersection	Node	Approach	Total Vehicles					
			Inbound/Outbound					
			AM Peak Hour					
			L2	L	T	R	R2	Total
W 72nd St and West End St 2019 (TMC-042)	1							
W 72nd St	1	EB	0	10	131	116	0	
W 72nd St	1	WB	0	84	138	44	0	
West End St	1	NB	0	104	187	64	0	
West End St	1	SB	0	0	414	30	0	1322
W 61st St and West End St 2019 (TMC-043)	2							
W 61st St	2	EB	0	20	15	55	0	
W 61st St	2	WB	0	0	0	0	0	
West End St	2	NB	0	19	370	57	0	
West End St	2	SB	0	55	574	35	0	1200
W 79th St and Riverside Dr 2019 (TMC-044)	3	NEB						
W 79th St	3	EB	0	5	502	330	0	
W 79th St	3	WB	0	5	590	25	0	
Riverside Dr	3	NB	0	60	30	10	0	
Riverside Dr	3	SB	0	15	130	154	0	1856
W 79th St and Riverside Dr 2019 (TMC-044)	333							
W 79th St	333	EB	0	0	0	0	0	
W 79th St	333	WB	0	0	0	0	0	
Riverside Dr	333	NB	0	0	0	0	0	
Riverside Dr	333	SB	0	0	0	0	0	0
W 56th St and West Side Hwy 2019 (TMC-045)	4							
-	4	EB	0	465	705	0	0	
W 56th St	4	WB	0	0	0	0	0	
West Side Hwy	4	NB	0	0	212	100	0	
West Side Hwy	4	SB	0	0	0	0	0	1482
W 56th St and West Side Hwy 2019 (TMC-045)	444							
-	444	EB	0	0	0	0	0	
W 56th St	444	WB	0	0	0	0	0	
West Side Hwy	444	NB	0	0	2143	0	0	
West Side Hwy	444	SB	0	1170	2958	0	0	6271
W 55th St and West Side Hwy 2019 (TMC-046)	5							
-	5	EB	0	0	0	0	0	
W 55th St	5	WB	0	126	30	130	0	
West Side Hwy	5	NB	0	75	2013	0	0	
West Side Hwy	5	SB	0	0	2958	0	0	5332

W 55th St and West Side Hwy									
2019 (TMC-046 B B)		55							
-	55	EB	0	0	0	0	0		
W 55th St	55	WB	0	0	286	30	0		
West Side Hwy	55	NB	0	0	282	0	0		
West Side Hwy	55	SB	0	0	0	0	0		598
W 55th St and West Side Hwy									
2019 (TMC-046)		555							
-	555	EB	0	0	0	0	0		
W 55th St	555	WB	0	105	0	0	0		
West Side Hwy	555	NB	0	0	0	0	0		
West Side Hwy	555	SB	0	0	0	0	0		105
W 60th St and Broadway									
2019 (TMC-047)		6							
-	6	EB	0	0	0	0	0		
W 60th St	6	WB	0	0	0	0	0		
Broadway	6	NB	0	328	503	0	0		
Broadway	6	SB	0	0	845	64	0		1740
W 60th St and Columbus Ave									
2019 (TMC-048)		7							
W 60th St	7	EB	0	0	0	0	0		
W 60th St	7	WB	0	235	157	0	0		
Columbus Ave	7	NB	0	0	0	0	0		
Columbus Ave	7	SB	0	0	972	78	0		1442
W 60th St and 10th Ave									
2019 (TMC-049)		8							
W 60th St	8	EB	0	0	0	0	0		
W 60th St	8	WB	0	0	170	65	0		
10th Ave	8	NB	0	91	912	0	0		
10th Ave	8	SB	0	0	0	0	0		1238
W 60th St and 11th Ave									
2019 (TMC-050)		9							
W 60th St	9	EB	0	5	0	30	0		
W 60th St	9	WB	0	140	52	69	0		
11th Ave	9	NB	0	19	372	0	0		
11th Ave	9	SB	0	0	609	20	0		1316
W 61st St and 10th Ave									
2019 (TMC-051)		10							
W 61st St	10	EB	0	117	10	0	0		
W 61st St	10	WB	0	0	0	10	0		
10th Ave	10	NB	0	0	972	5	0		
10th Ave	10	SB	0	0	0	0	0		1114

W 61st St and Columbus Ave									
2019 (TMC-052)	11								
-	11	EB	0	0	0	0	0		
W 61st St	11	WB	0	0	0	0	0		
Columbus Ave	11	NB	0	0	0	0	0		
Columbus Ave	11	SB	0	182	1050	0	0		1232
W 61st St and Broadway									
2019 (TMC-053)	12								
W 61st St	12	EB	0	30	44	108	0		
W 61st St	12	WB	0	0	0	0	0		
Broadway	12	NB	0	0	493	10	0		
Broadway	12	SB	0	20	801	0	0		1506
Central Park and W 61st St									
2019 (TMC-054)	13								
W 61st St	13	EB	0	74	0	0	0		
-	13	WB	0	0	0	0	0		
Central Park	13	NB	0	0	598	0	0		
Central Park	13	SB	0	0	0	0	0		672
Central Park and W 81st St									
2019 (TMC-055)	14								
W 81st St	14	EB	0	15	312	10	0		
W 79th St Transverse	14	WB	0	167	224	118	0		
Central Park	14	NB	0	15	224	169	0		
Central Park	14	SB	0	165	385	45	0		1849
Central Park West and W 66th St									
2019 (TMC-056)	15								
W 66th St	15	EB	0	0	0	0	0		
W 66th St	15	WB	0	177	314	231	0		
Central Park West	15	NB	0	65	353	0	0		
Central Park West	15	SB	0	0	656	45	0		1841
Central Park West and W 65th St									
2019 (TMC-057)	16								
W 65th St	16	EB	0	30	499	25	0		
W 65th St	16	WB	0	0	0	0	0		
Central Park West	16	NB	0	0	388	255	0		
Central Park West	16	SB	0	370	463	0	0		2030

CBD Tolling
UW #1 - Traffic Flowmap
MD No-Action



- Legend:**
- 1 - Intersection (2019 Collected Data)
 - 7 - Intersection (Uncollected Data)
 - 100 - ATR Volume
 - 100 - Approach Volume

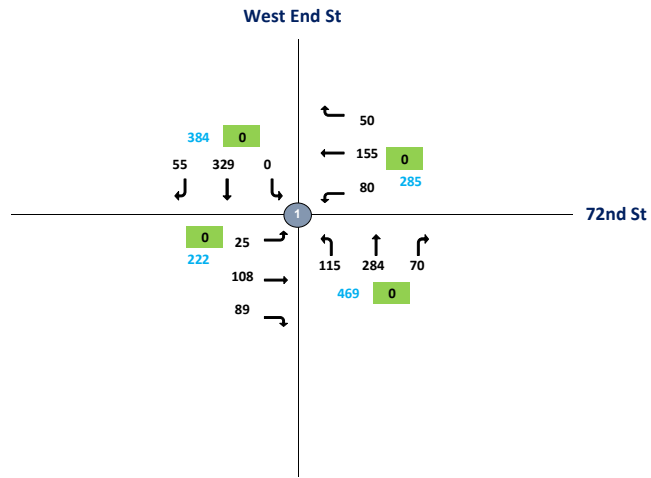

CBD Tolling
UW #2 - Traffic Flowmap
MD No-Action



- Legend:**
- 1 - Intersection (2019 Collected Data)
 - 2 - Intersection (Uncollected Data)
 - 100 - ATR Volume
 - 100 - Approach Volume

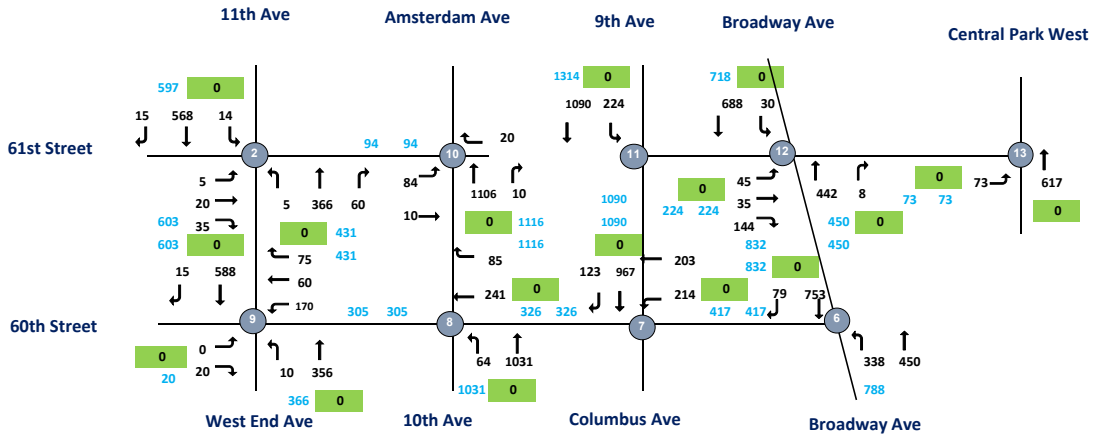

CBD Tolling
UW #3 - Traffic Flowmap
MD No-Action



- Legend:**
- 1 - Intersection (2019 Collected Data)
 - 7 - Intersection (Uncollected Data)
 - 100 - ATR Volume
 - 100 - Approach Volume

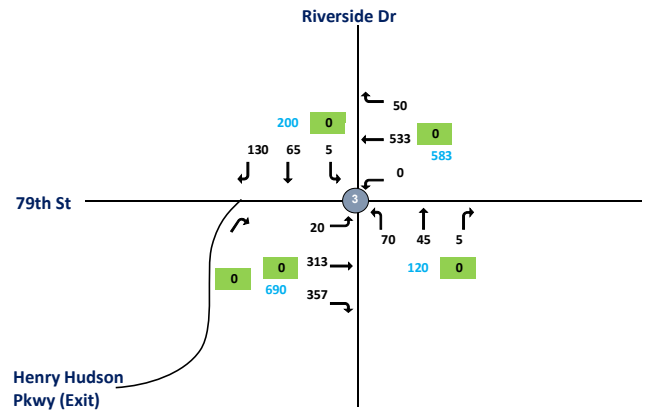

CBD Tolling
UW #4 - Traffic Flowmap
MD No-Action



- Legend:**
- 1 - Intersection (2019 Collected Data)
 - 7 - Intersection (Uncollected Data)
 - 100 - ATR Volume
 - 100 - Approach Volume

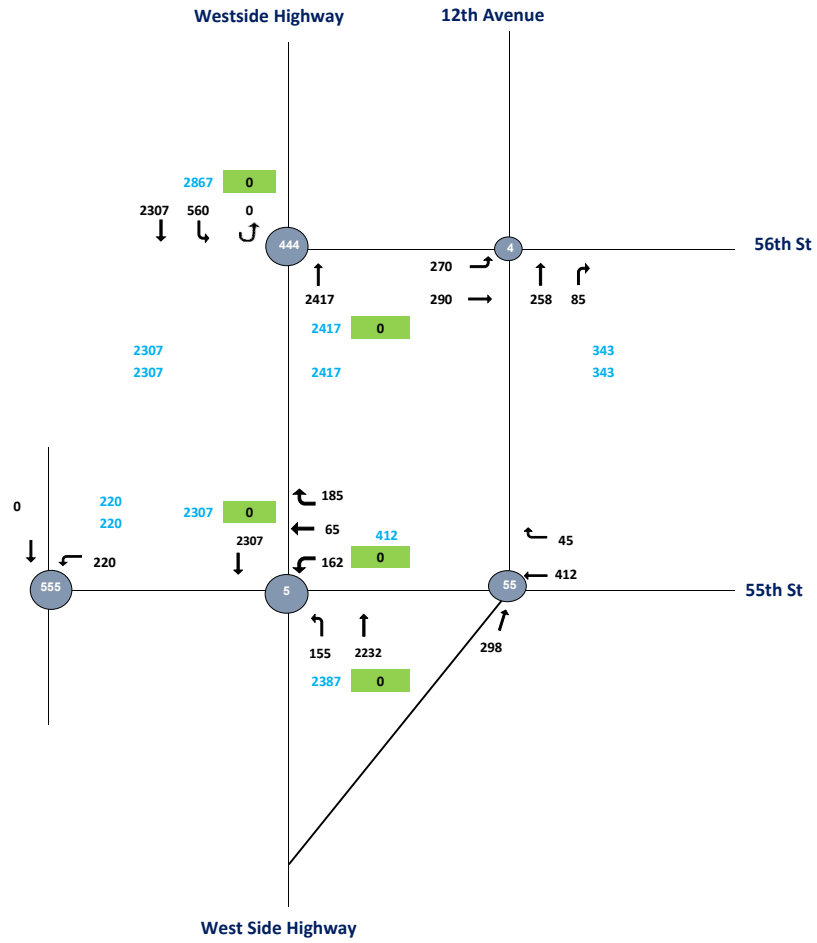

CBD Tolling
UW #5 - Traffic Flowmap
MD No-Action



- Legend:**
- 1 - Intersection (2019 Collected Data)
 - 7 - Intersection (Uncollected Data)
 - 100 - ATR Volume
 - 100 - Approach Volume

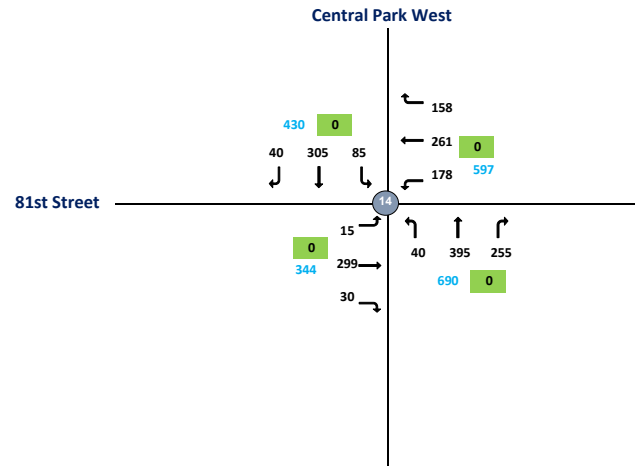

CBD Tolling
UW #6 - Traffic Flowmap
MD No-Action



- Legend:**
- 1 - Intersection (2019 Collected Data)
 - 7 - Intersection (Uncollected Data)
 - 100 - ATR Volume
 - 100 - Approach Volume

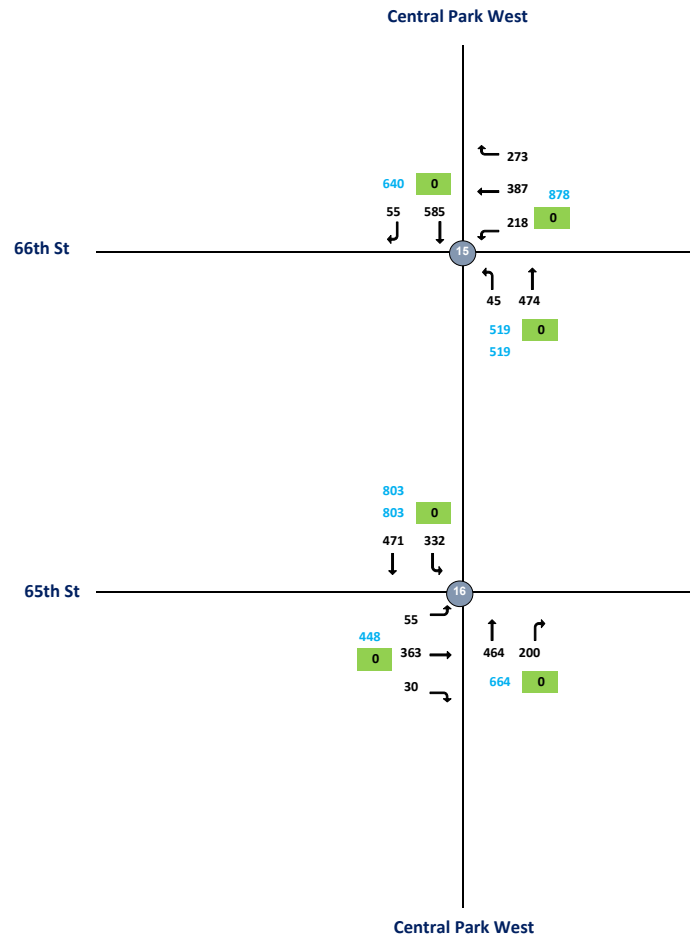

Intersection	Node	Approach	Total Vehicles					
			Inbound/Outbound					
			MD Peak Hour					
			L2	L	T	R	R2	Total
W 72nd St and West End St 2019 (TMC-042)	1							
W 72nd St	1	EB	0	25	108	89	0	
W 72nd St	1	WB	0	80	155	50	0	
West End St	1	NB	0	115	284	70	0	
West End St	1	SB	0	0	329	55	0	1360
W 61st St and West End St 2019 (TMC-043)	2							
W 61st St	2	EB	0	5	20	35	0	
W 61st St	2	WB	0	0	0	0	0	
West End St	2	NB	0	5	366	60	0	
West End St	2	SB	0	14	568	15	0	1088
W 79th St and Riverside Dr 2019 (TMC-044)	3	NEB						
W 79th St	3	EB	0	20	313	357	0	
W 79th St	3	WB	0	0	533	50	0	
Riverside Dr	3	NB	0	70	45	5	0	
Riverside Dr	3	SB	0	5	65	130	0	1593
W 79th St and Riverside Dr 2019 (TMC-044)	333							
W 79th St	333	EB	0	0	0	0	0	
W 79th St	333	WB	0	0	0	0	0	
Riverside Dr	333	NB	0	0	0	0	0	
Riverside Dr	333	SB	0	0	0	0	0	0
W 56th St and West Side Hwy 2019 (TMC-045)	4							
-	4	EB	0	270	290	0	0	
W 56th St	4	WB	0	0	0	0	0	
West Side Hwy	4	NB	0	0	258	85	0	
West Side Hwy	4	SB	0	0	0	0	0	903
W 56th St and West Side Hwy 2019 (TMC-045)	444							
-	444	EB	0	0	0	0	0	
W 56th St	444	WB	0	0	0	0	0	
West Side Hwy	444	NB	0	0	2417	0	0	
West Side Hwy	444	SB	0	560	2307	0	0	5284
W 55th St and West Side Hwy 2019 (TMC-046)	5							
-	5	EB	0	0	0	0	0	
W 55th St	5	WB	0	162	65	185	0	
West Side Hwy	5	NB	0	155	2232	0	0	
West Side Hwy	5	SB	0	0	2307	0	0	5106

W 55th St and West Side Hwy									
2019 (TMC-046 B B)		55							
-	55	EB	0	0	0	0	0		
W 55th St	55	WB	0	0	412	45	0		
West Side Hwy	55	NB	0	0	298	0	0		
West Side Hwy	55	SB	0	0	0	0	0		755
W 55th St and West Side Hwy									
2019 (TMC-046)		555							
-	555	EB	0	0	0	0	0		
W 55th St	555	WB	0	220	0	0	0		
West Side Hwy	555	NB	0	0	0	0	0		
West Side Hwy	555	SB	0	0	0	0	0		220
W 60th St and Broadway									
2019 (TMC-047)		6							
-	6	EB	0	0	0	0	0		
W 60th St	6	WB	0	0	0	0	0		
Broadway	6	NB	0	338	450	0	0		
Broadway	6	SB	0	0	753	79	0		1620
W 60th St and Columbus Ave									
2019 (TMC-048)		7							
W 60th St	7	EB	0	0	0	0	0		
W 60th St	7	WB	0	214	203	0	0		
Columbus Ave	7	NB	0	0	0	0	0		
Columbus Ave	7	SB	0	0	967	123	0		1507
W 60th St and 10th Ave									
2019 (TMC-049)		8							
W 60th St	8	EB	0	0	0	0	0		
W 60th St	8	WB	0	0	241	85	0		
10th Ave	8	NB	0	64	1031	0	0		
10th Ave	8	SB	0	0	0	0	0		1421
W 60th St and 11th Ave									
2019 (TMC-050)		9							
W 60th St	9	EB	0	0	0	20	0		
W 60th St	9	WB	0	170	60	75	0		
11th Ave	9	NB	0	10	356	0	0		
11th Ave	9	SB	0	0	588	15	0		1294
W 61st St and 10th Ave									
2019 (TMC-051)		10							
W 61st St	10	EB	0	84	10	0	0		
W 61st St	10	WB	0	0	0	20	0		
10th Ave	10	NB	0	0	1106	10	0		
10th Ave	10	SB	0	0	0	0	0		1230

W 61st St and Columbus Ave									
2019 (TMC-052)	11								
-	11	EB	0	0	0	0	0	0	
W 61st St	11	WB	0	0	0	0	0	0	
Columbus Ave	11	NB	0	0	0	0	0	0	
Columbus Ave	11	SB	0	224	1090	0	0	0	1314
W 61st St and Broadway									
2019 (TMC-053)	12								
W 61st St	12	EB	0	45	35	144	0	0	
W 61st St	12	WB	0	0	0	0	0	0	
Broadway	12	NB	0	0	442	8	0	0	
Broadway	12	SB	0	30	688	0	0	0	1392
Central Park and W 61st St									
2019 (TMC-054)	13								
W 61st St	13	EB	0	73	0	0	0	0	
-	13	WB	0	0	0	0	0	0	
Central Park	13	NB	0	0	617	0	0	0	
Central Park	13	SB	0	0	0	0	0	0	690
Central Park and W 81st St									
2019 (TMC-055)	14								
W 81st St	14	EB	0	15	299	30	0	0	
W 79th St Transverse	14	WB	0	178	261	158	0	0	
Central Park	14	NB	0	40	395	255	0	0	
Central Park	14	SB	0	85	305	40	0	0	2061
Central Park West and W 66th St									
2019 (TMC-056)	15								
W 66th St	15	EB	0	0	0	0	0	0	
W 66th St	15	WB	0	218	387	273	0	0	
Central Park West	15	NB	0	45	474	0	0	0	
Central Park West	15	SB	0	0	585	55	0	0	2037
Central Park West and W 65th St									
2019 (TMC-057)	16								
W 65th St	16	EB	0	55	363	30	0	0	
W 65th St	16	WB	0	0	0	0	0	0	
Central Park West	16	NB	0	0	464	200	0	0	
Central Park West	16	SB	0	332	471	0	0	0	1915

CBD Tolling
UW #1 - Traffic Flowmap
PM No-Action



- Legend:**
- 1 - Intersection (2019 Collected Data)
 - 7 - Intersection (Uncollected Data)
 - 100 - ATR Volume
 - 100 - Approach Volume

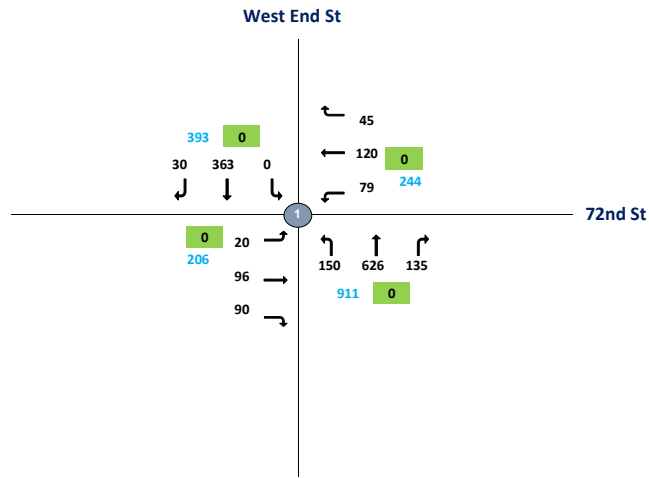

CBD Tolling
UW #2 - Traffic Flowmap
PM No-Action



- Legend:**
- 1 - Intersection (2019 Collected Data)
 - 2 - Intersection (Uncollected Data)
 - 100 - ATR Volume
 - 100 - Approach Volume

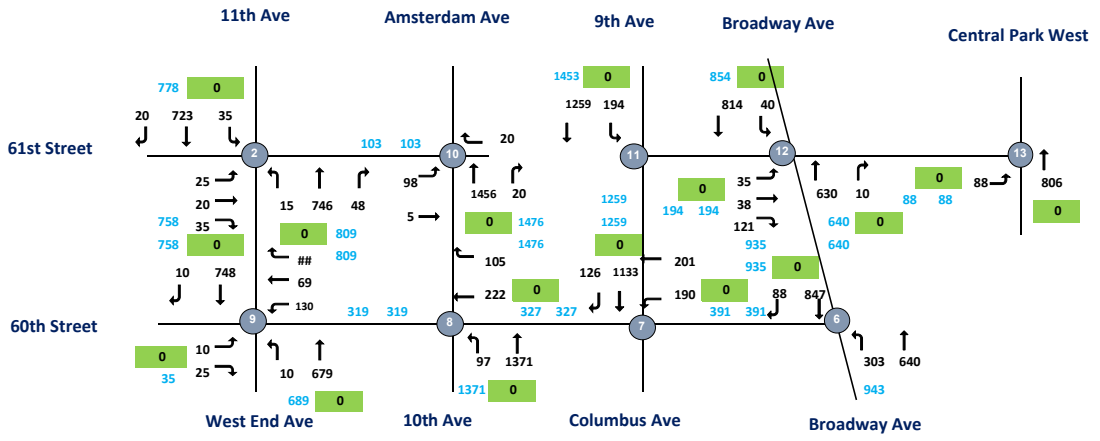

CBD Tolling
UW #3 - Traffic Flowmap
PM No-Action



- Legend:**
- 1 - Intersection (2019 Collected Data)
 - ? - Intersection (Uncollected Data)
 - 100 - ATR Volume
 - 100 - Approach Volume

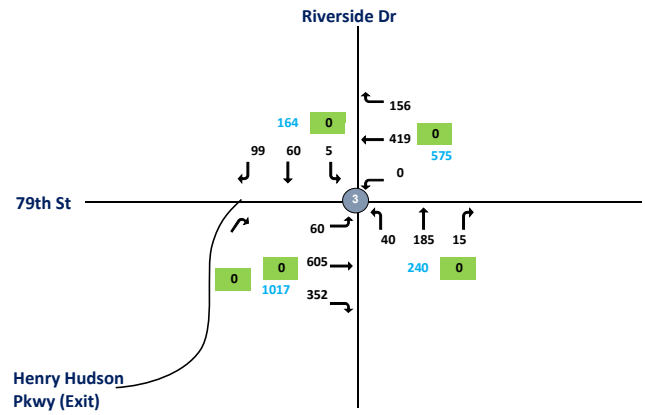

CBD Tolling
UW #5 - Traffic Flowmap
PM No-Action



- Legend:**
- 1 - Intersection (2019 Collected Data)
 - 7 - Intersection (Uncollected Data)
 - 100 - ATR Volume
 - 100 - Approach Volume

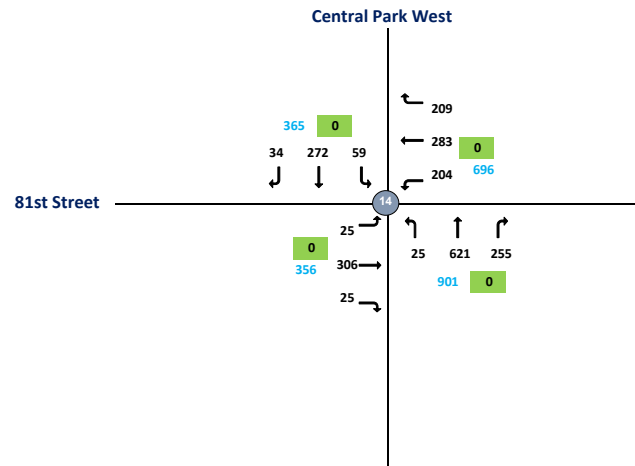

CBD Tolling
UW #6 - Traffic Flowmap
PM No-Action



- Legend:**
- 1 - Intersection (2019 Collected Data)
 - 7 - Intersection (Uncollected Data)
 - 100 - ATR Volume
 - 100 - Approach Volume

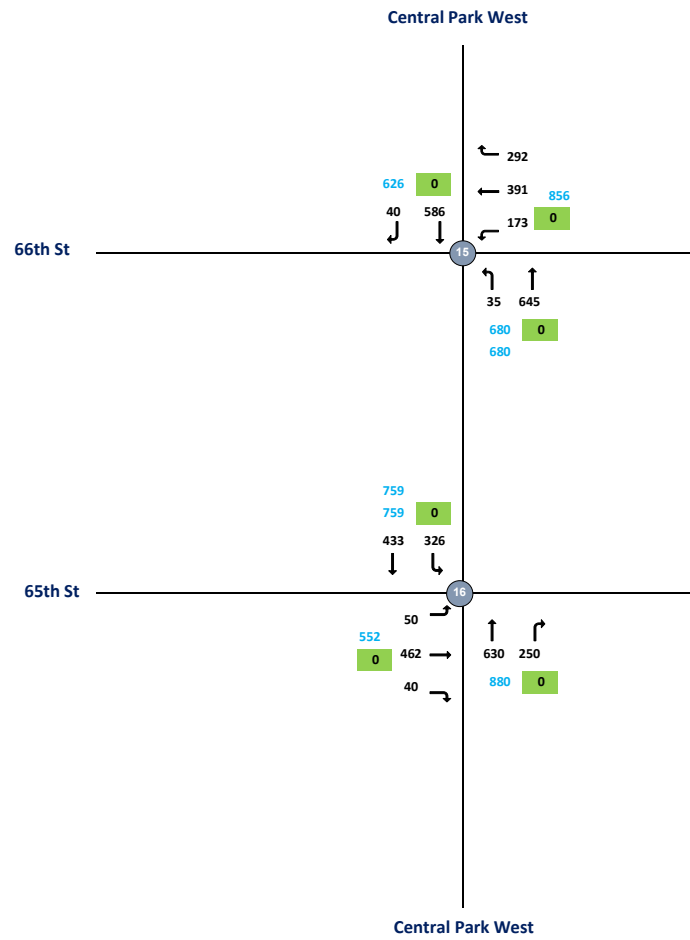

Intersection	Node	Approach	Total Vehicles					
			Inbound/Outbound					
			PM Peak Hour					
			L2	L	T	R	R2	Total
W 72nd St and West End St 2019 (TMC-042)	1							
W 72nd St	1	EB	0	20	96	90	0	
W 72nd St	1	WB	0	79	120	45	0	
West End St	1	NB	0	150	626	135	0	
West End St	1	SB	0	0	363	30	0	1754
W 61st St and West End St 2019 (TMC-043)	2							
W 61st St	2	EB	0	25	20	35	0	
W 61st St	2	WB	0	0	0	0	0	
West End St	2	NB	0	15	746	48	0	
West End St	2	SB	0	35	723	20	0	1667
W 79th St and Riverside Dr 2019 (TMC-044)	3	NEB						
W 79th St	3	EB	0	60	605	352	0	
W 79th St	3	WB	0	0	419	156	0	
Riverside Dr	3	NB	0	40	185	15	0	
Riverside Dr	3	SB	0	5	60	99	0	1996
W 79th St and Riverside Dr 2019 (TMC-044)	333							
W 79th St	333	EB	0	0	0	0	0	
W 79th St	333	WB	0	0	0	0	0	
Riverside Dr	333	NB	0	0	0	0	0	
Riverside Dr	333	SB	0	0	0	0	0	0
W 56th St and West Side Hwy 2019 (TMC-045)	4							
-	4	EB	0	160	410	0	0	
W 56th St	4	WB	0	0	0	0	0	
West Side Hwy	4	NB	0	0	290	129	0	
West Side Hwy	4	SB	0	0	0	0	0	989
W 56th St and West Side Hwy 2019 (TMC-045)	444							
-	444	EB	0	0	0	0	0	
W 56th St	444	WB	0	0	0	0	0	
West Side Hwy	444	NB	0	0	2667	0	0	
West Side Hwy	444	SB	0	570	2014	0	0	5251
W 55th St and West Side Hwy 2019 (TMC-046)	5							
-	5	EB	0	0	0	0	0	
W 55th St	5	WB	0	315	10	189	0	
West Side Hwy	5	NB	0	15	2478	0	0	
West Side Hwy	5	SB	0	0	2014	0	0	5021

W 55th St and West Side Hwy									
2019 (TMC-046 B B)		55							
-	55	EB	0	0	0	0	0		
W 55th St	55	WB	0	0	514	20	0		
West Side Hwy	55	NB	0	0	399	0	0		
West Side Hwy	55	SB	0	0	0	0	0		933
W 55th St and West Side Hwy									
2019 (TMC-046)		555							
-	555	EB	0	0	0	5	0		
W 55th St	555	WB	0	25	0	0	0		
West Side Hwy	555	NB	0	0	0	0	0		
West Side Hwy	555	SB	0	0	0	0	0		30
W 60th St and Broadway									
2019 (TMC-047)		6							
-	6	EB	0	0	0	0	0		
W 60th St	6	WB	0	0	0	0	0		
Broadway	6	NB	0	303	640	0	0		
Broadway	6	SB	0	0	847	88	0		1878
W 60th St and Columbus Ave									
2019 (TMC-048)		7							
W 60th St	7	EB	0	0	0	0	0		
W 60th St	7	WB	0	190	201	0	0		
Columbus Ave	7	NB	0	0	0	0	0		
Columbus Ave	7	SB	0	0	1133	126	0		1650
W 60th St and 10th Ave									
2019 (TMC-049)		8							
W 60th St	8	EB	0	0	0	0	0		
W 60th St	8	WB	0	0	222	105	0		
10th Ave	8	NB	0	97	1371	0	0		
10th Ave	8	SB	0	0	0	0	0		1795
W 60th St and 11th Ave									
2019 (TMC-050)		9							
W 60th St	9	EB	0	10	0	25	0		
W 60th St	9	WB	0	130	69	120	0		
11th Ave	9	NB	0	10	679	0	0		
11th Ave	9	SB	0	0	748	10	0		1801
W 61st St and 10th Ave									
2019 (TMC-051)		10							
W 61st St	10	EB	0	98	5	0	0		
W 61st St	10	WB	0	0	0	20	0		
10th Ave	10	NB	0	0	1456	20	0		
10th Ave	10	SB	0	0	0	0	0		1599

W 61st St and Columbus Ave									
2019 (TMC-052)	11								
-	11	EB	0	0	0	0	0		
W 61st St	11	WB	0	0	0	0	0		
Columbus Ave	11	NB	0	0	0	0	0		
Columbus Ave	11	SB	0	194	1259	0	0		1453
W 61st St and Broadway									
2019 (TMC-053)	12								
W 61st St	12	EB	0	35	38	121	0		
W 61st St	12	WB	0	0	0	0	0		
Broadway	12	NB	0	0	630	10	0		
Broadway	12	SB	0	40	814	0	0		1688
Central Park and W 61st St									
2019 (TMC-054)	13								
W 61st St	13	EB	0	88	0	0	0		
-	13	WB	0	0	0	0	0		
Central Park	13	NB	0	0	806	0	0		
Central Park	13	SB	0	0	0	0	0		894
Central Park and W 81st St									
2019 (TMC-055)	14								
W 81st St	14	EB	0	25	306	25	0		
W 79th St Transverse	14	WB	0	204	283	209	0		
Central Park	14	NB	0	25	621	255	0		
Central Park	14	SB	0	59	272	34	0		2318
Central Park West and W 66th St									
2019 (TMC-056)	15								
W 66th St	15	EB	0	0	0	0	0		
W 66th St	15	WB	0	173	391	292	0		
Central Park West	15	NB	0	35	645	0	0		
Central Park West	15	SB	0	0	586	40	0		2162
Central Park West and W 65th St									
2019 (TMC-057)	16								
W 65th St	16	EB	0	50	462	40	0		
W 65th St	16	WB	0	0	0	0	0		
Central Park West	16	NB	0	0	630	250	0		
Central Park West	16	SB	0	326	433	0	0		2191

CBD Tolling
UW #1 - Traffic Flowmap
LN No-Action



- Legend:**
- 1 - Intersection (2019 Collected Data)
 - 7 - Intersection (Uncollected Data)
 - 100 - ATR Volume
 - 100 - Approach Volume

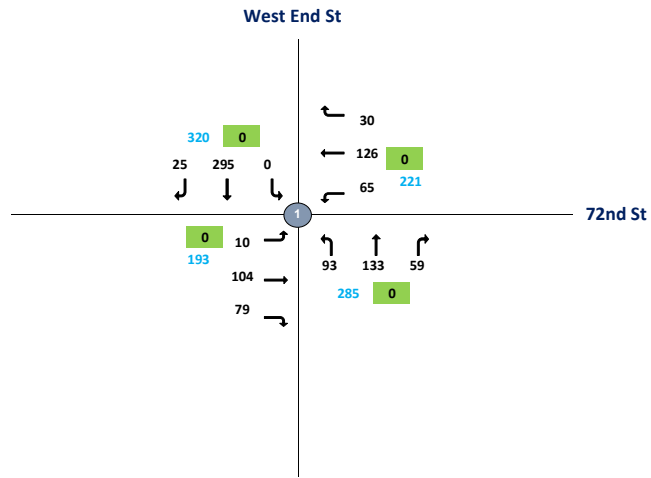

CBD Tolling
UW #2 - Traffic Flowmap
LN No-Action



- Legend:**
- - Intersection (2019 Collected Data)
 - - Intersection (Uncollected Data)
 - 100 - ATR Volume
 - 100 - Approach Volume

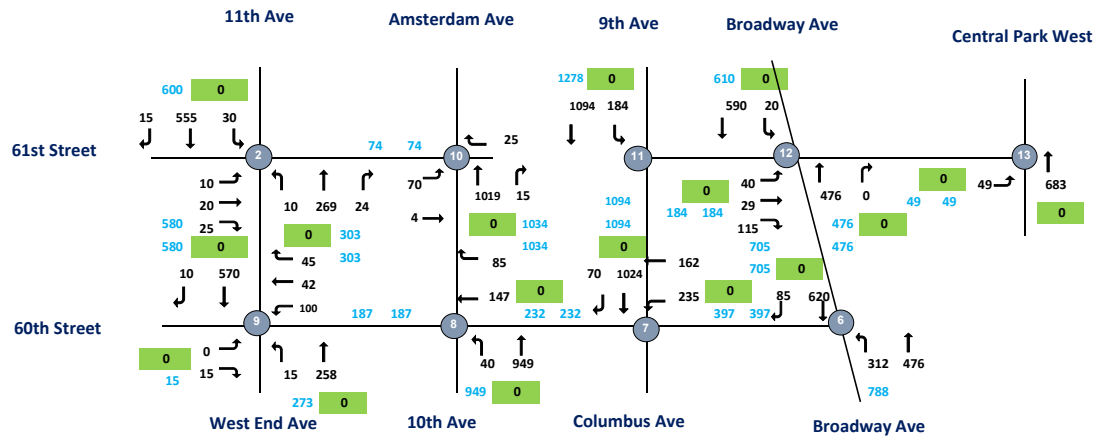

CBD Tolling
UW #3 - Traffic Flowmap
LN No-Action



- Legend:**
- Intersection (2019 Collected Data)
 - Intersection (Uncollected Data)
 - ATR Volume
 - Approach Volume

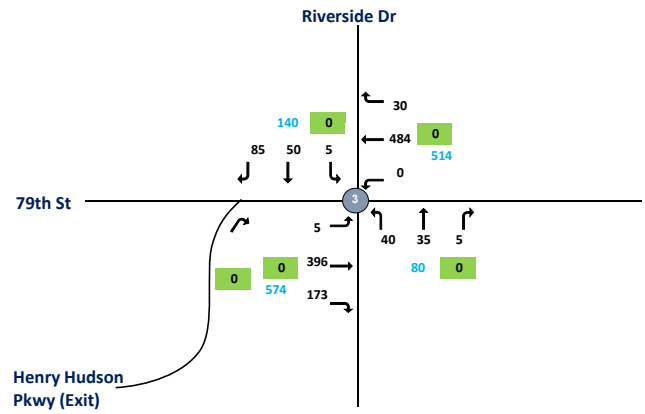

CBD Tolling
UW #4 - Traffic Flowmap
LN No-Action



- Legend:**
- 1 - Intersection (2019 Collected Data)
 - 7 - Intersection (Uncollected Data)
 - 100 - ATR Volume
 - 100 - Approach Volume

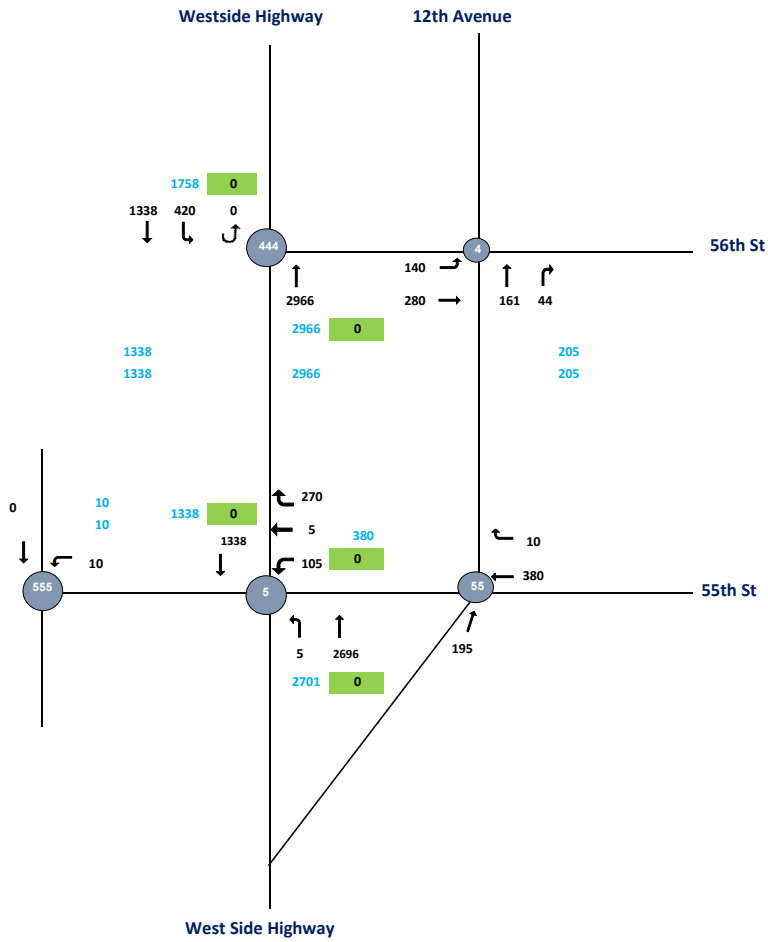

CBD Tolling
UW #5 - Traffic Flowmap
LN No-Action



- Legend:**
- 1 - Intersection (2019 Collected Data)
 - 7 - Intersection (Uncollected Data)
 - 100 - ATR Volume
 - 100 - Approach Volume

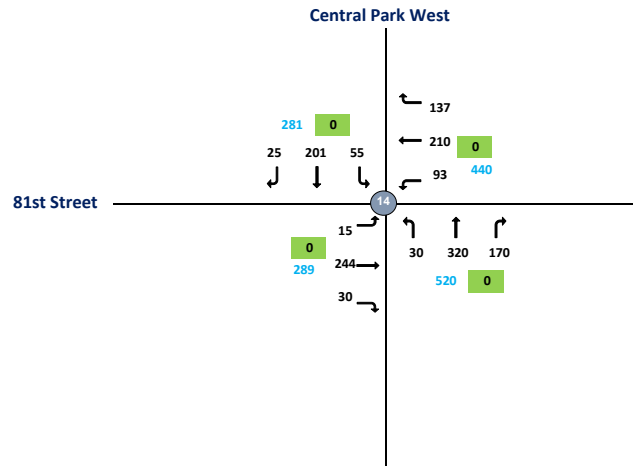

CBD Tolling
UW #6 - Traffic Flowmap
LN No-Action



- Legend:**
- 1 - Intersection (2019 Collected Data)
 - 7 - Intersection (Uncollected Data)
 - 100 - ATR Volume
 - 100 - Approach Volume

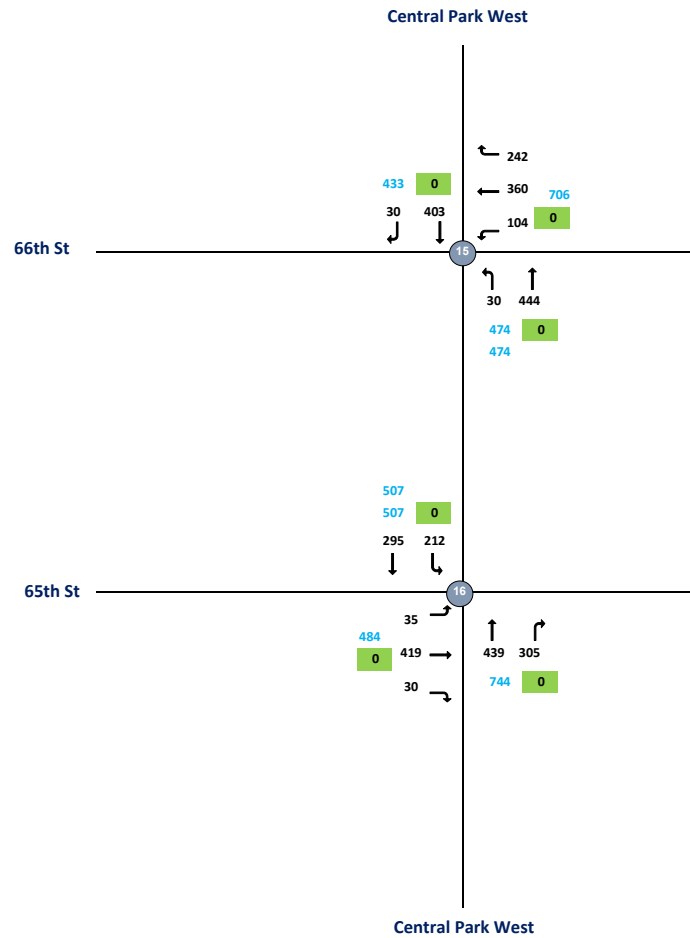

Intersection	Node	Approach	Total Vehicles					
			Inbound/Outbound					
			LN Peak Hour					
			L2	L	T	R	R2	Total
W 72nd St and West End St 2019 (TMC-042)	1							
W 72nd St	1	EB	0	10	104	79	0	
W 72nd St	1	WB	0	65	126	30	0	
West End St	1	NB	0	93	133	59	0	
West End St	1	SB	0	0	295	25	0	1019
W 61st St and West End St 2019 (TMC-043)	2							
W 61st St	2	EB	0	10	20	25	0	
W 61st St	2	WB	0	0	0	0	0	
West End St	2	NB	0	10	269	24	0	
West End St	2	SB	0	30	555	15	0	958
W 79th St and Riverside Dr 2019 (TMC-044)	3	NEB						
W 79th St	3	EB	0	5	396	173	0	
W 79th St	3	WB	0	0	484	30	0	
Riverside Dr	3	NB	0	40	35	5	0	
Riverside Dr	3	SB	0	5	50	85	0	1308
W 79th St and Riverside Dr 2019 (TMC-044)	333							
W 79th St	333	EB	0	0	0	0	0	
W 79th St	333	WB	0	0	0	0	0	
Riverside Dr	333	NB	0	0	0	0	0	
Riverside Dr	333	SB	0	0	0	0	0	0
W 56th St and West Side Hwy 2019 (TMC-045)	4							
-	4	EB	0	140	280	0	0	
W 56th St	4	WB	0	0	0	0	0	
West Side Hwy	4	NB	0	0	161	44	0	
West Side Hwy	4	SB	0	0	0	0	0	625
W 56th St and West Side Hwy 2019 (TMC-045)	444							
-	444	EB	0	0	0	0	0	
W 56th St	444	WB	0	0	0	0	0	
West Side Hwy	444	NB	0	0	2966	0	0	
West Side Hwy	444	SB	0	420	1338	0	0	4724
W 55th St and West Side Hwy 2019 (TMC-046)	5							
-	5	EB	0	0	0	0	0	
W 55th St	5	WB	0	105	5	270	0	
West Side Hwy	5	NB	0	5	2696	0	0	
West Side Hwy	5	SB	0	0	1338	0	0	4419

W 55th St and West Side Hwy									
2019 (TMC-046 B B)		55							
-	55	EB	0	0	0	0	0		
W 55th St	55	WB	0	0	380	10	0		
West Side Hwy	55	NB	0	0	195	0	0		
West Side Hwy	55	SB	0	0	0	0	0		585
W 55th St and West Side Hwy									
2019 (TMC-046)		555							
-	555	EB	0	0	0	0	0		
W 55th St	555	WB	0	10	0	0	0		
West Side Hwy	555	NB	0	0	0	0	0		
West Side Hwy	555	SB	0	0	0	0	0		10
W 60th St and Broadway									
2019 (TMC-047)		6							
-	6	EB	0	0	0	0	0		
W 60th St	6	WB	0	0	0	0	0		
Broadway	6	NB	0	312	476	0	0		
Broadway	6	SB	0	0	620	85	0		1493
W 60th St and Columbus Ave									
2019 (TMC-048)		7							
W 60th St	7	EB	0	0	0	0	0		
W 60th St	7	WB	0	235	162	0	0		
Columbus Ave	7	NB	0	0	0	0	0		
Columbus Ave	7	SB	0	0	1024	70	0		1491
W 60th St and 10th Ave									
2019 (TMC-049)		8							
W 60th St	8	EB	0	0	0	0	0		
W 60th St	8	WB	0	0	147	85	0		
10th Ave	8	NB	0	40	949	0	0		
10th Ave	8	SB	0	0	0	0	0		1221
W 60th St and 11th Ave									
2019 (TMC-050)		9							
W 60th St	9	EB	0	0	0	15	0		
W 60th St	9	WB	0	100	42	45	0		
11th Ave	9	NB	0	15	258	0	0		
11th Ave	9	SB	0	0	570	10	0		1055
W 61st St and 10th Ave									
2019 (TMC-051)		10							
W 61st St	10	EB	0	70	4	0	0		
W 61st St	10	WB	0	0	0	25	0		
10th Ave	10	NB	0	0	1019	15	0		
10th Ave	10	SB	0	0	0	0	0		1133

W 61st St and Columbus Ave									
2019 (TMC-052)	11								
-	11	EB	0	0	0	0	0		
W 61st St	11	WB	0	0	0	0	0		
Columbus Ave	11	NB	0	0	0	0	0		
Columbus Ave	11	SB	0	184	1094	0	0		1278
W 61st St and Broadway									
2019 (TMC-053)	12								
W 61st St	12	EB	0	40	29	115	0		
W 61st St	12	WB	0	0	0	0	0		
Broadway	12	NB	0	0	476	0	0		
Broadway	12	SB	0	20	590	0	0		1270
Central Park and W 61st St									
2019 (TMC-054)	13								
W 61st St	13	EB	0	49	0	0	0		
-	13	WB	0	0	0	0	0		
Central Park	13	NB	0	0	683	0	0		
Central Park	13	SB	0	0	0	0	0		732
Central Park and W 81st St									
2019 (TMC-055)	14								
W 81st St	14	EB	0	15	244	30	0		
W 79th St Transverse	14	WB	0	93	210	137	0		
Central Park	14	NB	0	30	320	170	0		
Central Park	14	SB	0	55	201	25	0		1530
Central Park West and W 66th St									
2019 (TMC-056)	15								
W 66th St	15	EB	0	0	0	0	0		
W 66th St	15	WB	0	104	360	242	0		
Central Park West	15	NB	0	30	444	0	0		
Central Park West	15	SB	0	0	403	30	0		1613
Central Park West and W 65th St									
2019 (TMC-057)	16								
W 65th St	16	EB	0	35	419	30	0		
W 65th St	16	WB	0	0	0	0	0		
Central Park West	16	NB	0	0	439	305	0		
Central Park West	16	SB	0	212	295	0	0		1735

CBD Tolling
9A - Traffic Flowmap
AM Action Increment



- Legend:**
- 1 - Intersection (2019 Collected Data)
 - 7 - Intersection (Uncollected Data)
 - 100 - ATR Volume
 - 100 - Approach Volume

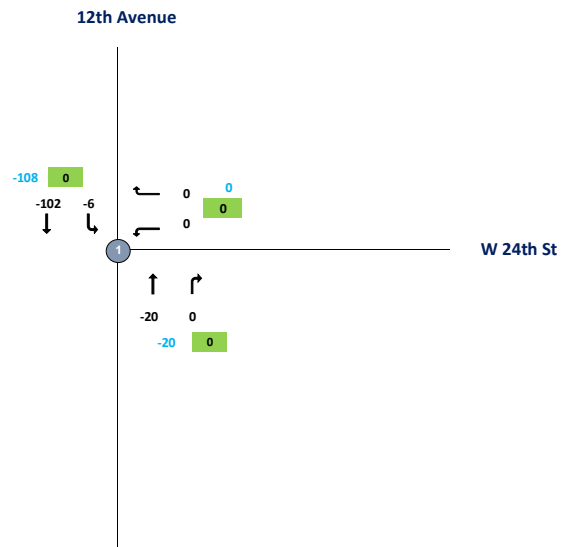

9A

8:00 AM

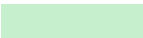

Intersection	Node	Approach	Total Vehicles					
			Inbound/Outbound					
			AM Peak Hour					
			L2	L	T	R	R2	Total
12th Ave & 24th Street 2019 (TMC-065)	1							
24th Street	1	EB	0	0	0	0	0	
24th Street	1	WB	0	0	0	0	0	
12th Ave	1	NB	0	0	-20	0	0	
12th Ave	1	SB	0	-6	-102	0	0	-128

CBD Tolling
9A - Traffic Flowmap
MD Action Increment



- Legend:**
- ① - Intersection (2019 Collected Data)
 - ⑦ - Intersection (Uncollected Data)
 - 100 - ATR Volume
 - 100 - Approach Volume

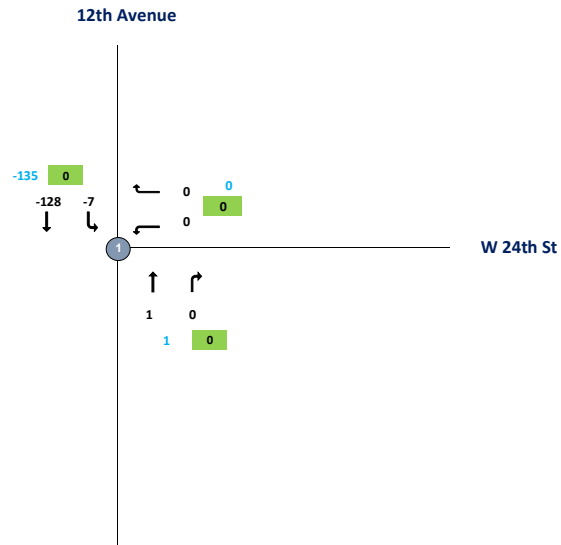

9A

1:00 PM

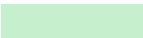

Intersection	Node	Approach	Total Vehicles					
			Inbound/Outbound					
			MD Peak Hour					
			L2	L	T	R	R2	Total
12th Ave & 24th Street 2019 (TMC-065)	1							
24th Street	1	EB	0	0	0	0	0	
24th Street	1	WB	0	0	0	0	0	
12th Ave	1	NB	0	0	1	0	0	
12th Ave	1	SB	0	-7	-128	0	0	-134

CBD Tolling
9A - Traffic Flowmap
PM Action Increment



- Legend:**
- 1 - Intersection (2019 Collected Data)
 - 7 - Intersection (Uncollected Data)
 - 100 - ATR Volume
 - 100 - Approach Volume

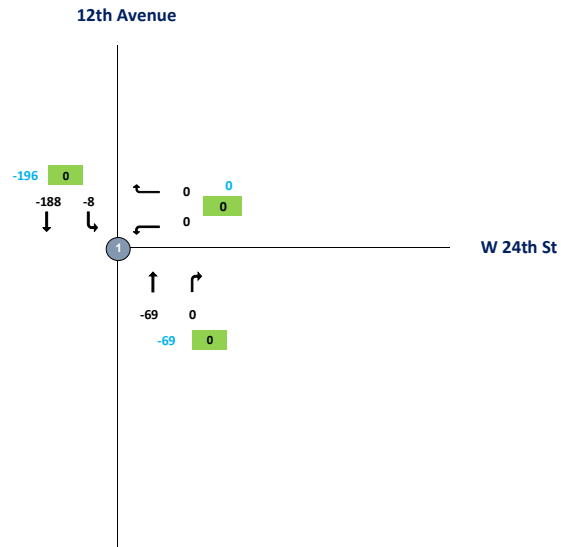

9A

5:00 PM

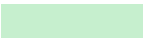

Intersection	Node	Approach	Total Vehicles					
			Inbound/Outbound					
			PM Peak Hour					
			L2	L	T	R	R2	Total
12th Ave & 24th Street 2019 (TMC-065)	1							
24th Street	1	EB	0	0	0	0	0	
24th Street	1	WB	0	0	0	0	0	
12th Ave	1	NB	0	0	-69	0	0	
12th Ave	1	SB	0	-8	-188	0	0	-265

CBD Tolling
9A - Traffic Flowmap
LN Action Increment



- Legend:**
- ① - Intersection (2019 Collected Data)
 - ⑦ - Intersection (Uncollected Data)
 - 100 - ATR Volume
 - 100 - Approach Volume

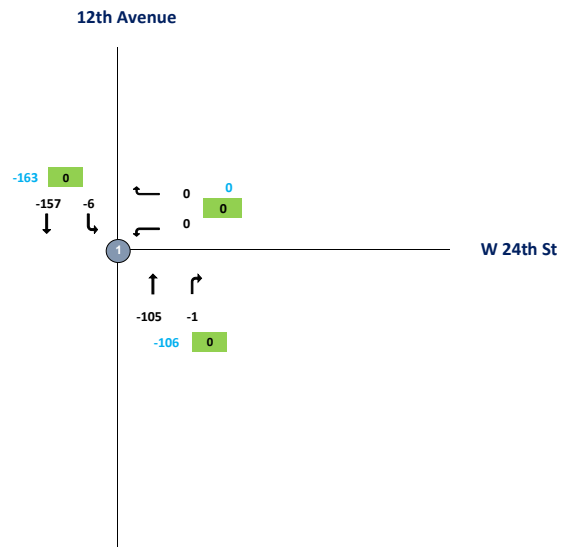

9A

9:00 PM

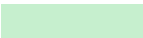

Intersection	Node	Approach	Total Vehicles					
			Inbound/Outbound					
			LN Peak Hour					
			L2	L	T	R	R2	Total
12th Ave & 24th Street 2019 (TMC-065)	1							
24th Street	1	EB	0	0	0	0	0	
24th Street	1	WB	0	0	0	0	0	
12th Ave	1	NB	0	0	-105	-1	0	
12th Ave	1	SB	0	-6	-157	0	0	-269

CBD Tolling
Dumbo - Traffic Flowmap
AM Action Increment



- Legend:**
- 1 - Intersection (2019 Collected Data)
 - 7 - Intersection (Uncollected Data)
 - 100 - ATR Volume
 - 100 - Approach Volume

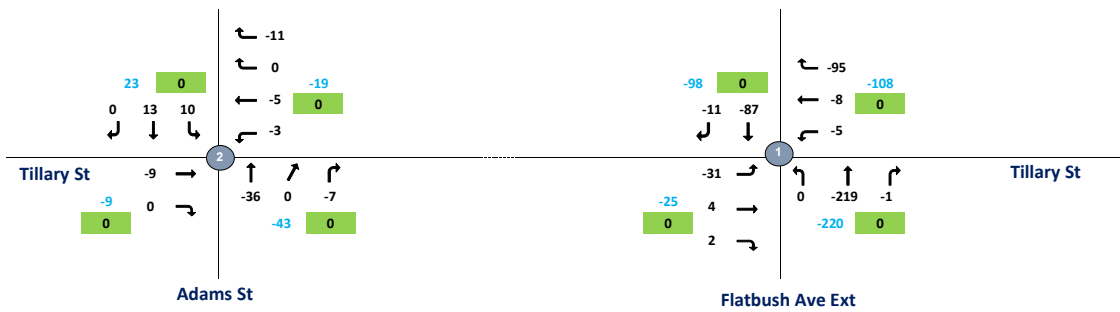

CBD Tolling
Dumbo #2 - Traffic Flowmap
AM Action Increment



- Legend:**
- Intersection (2019 Collected Data)
 - Intersection (Uncollected Data)
 - ATR Volume
 - Approach Volume

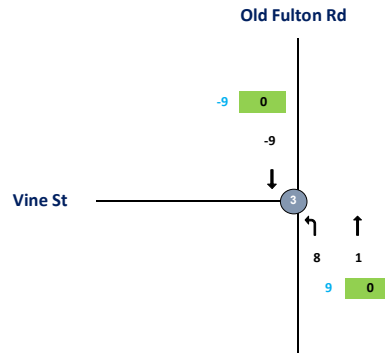

DUMBO

8:00:00 AM

Intersection	Node	Approach	Total Vehicles					Total
			Inbound/Outbound					
			AM Peak Hour					
			L2	L	T	R	R2	
Tillary St & Flatbush Ave ext 2019 (TMC-007)	1							
Tillary St	1	EB	0	-31	4	2	0	
Tillary St	1	WB	0	-5	-8	-95	0	
Flatbush Ave ext	1	NB	0	0	-219	-1	0	
Flatbush Ave ext	1	SB	0	0	-87	-11	0	-451
Tillary St & Adams St 2019 (TMC-008)	2							
Tillary St	2	EB	0	0	-9	0	0	
Tillary St	2	WB	0	-3	-5	0	-11	
Adams St	2	NB	0	0	-36	0	-7	
Adams St	2	SB	0	10	13	0	0	-48
Vine St & Old Fulton Rd 2019 (TMC-009)	3							
Vine St	3	EB	0	0	0	0	0	
Vine St	3	WB	0	0	0	0	0	
Old Fulton Rd	3	NB	0	8	1	0	0	
Old Fulton Rd	3	SB	0	0	-9	0	0	0

CBD Tolling
Dumbo - Traffic Flowmap
MD Action Increment



- Legend:**
- 1 - Intersection (2019 Collected Data)
 - 7 - Intersection (Uncollected Data)
 - 100 - ATR Volume
 - 100 - Approach Volume

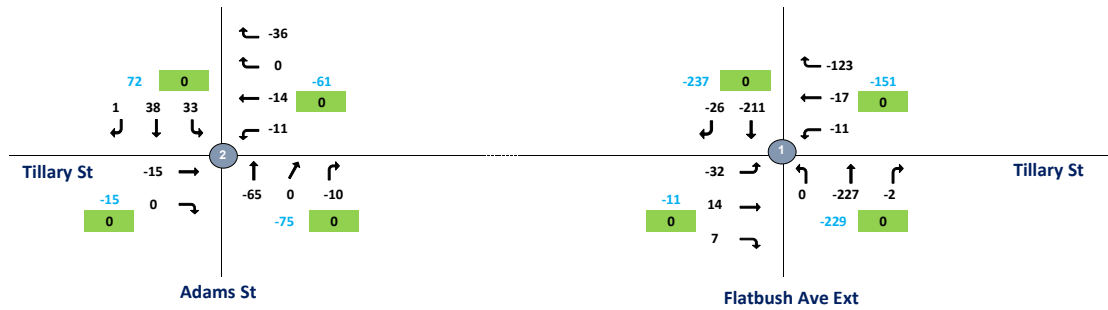

CBD Tolling
Dumbo #2 - Traffic Flowmap
MD Action Increment



- Legend:**
- 1 - Intersection (2019 Collected Data)
 - 7 - Intersection (Uncollected Data)
 - 100 - ATR Volume
 - 100 - Approach Volume

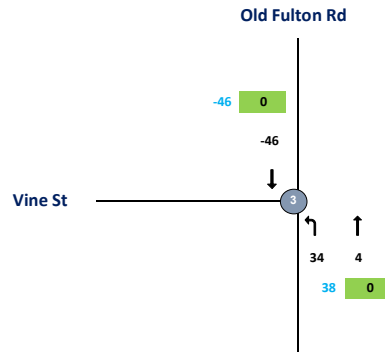

DUMBO

1:00:00 PM

Intersection	Node	Approach	Total Vehicles					Total
			Inbound/Outbound					
			MD Peak Hour					
L2	L	T	R	R2				
Tillary St & Flatbush Ave ext 2019 (TMC-007)	1							
Tillary St	1	EB	0	-32	14	7	0	
Tillary St	1	WB	0	-11	-17	-123	0	
Flatbush Ave ext	1	NB	0	0	-227	-2	0	
Flatbush Ave ext	1	SB	0	0	-211	-26	0	
							-628	
Tillary St & Adams St 2019 (TMC-008)	2							
Tillary St	2	EB	0	0	-15	0	0	
Tillary St	2	WB	0	-11	-14	0	-36	
Adams St	2	NB	0	0	-65	0	-10	
Adams St	2	SB	0	33	38	1	0	
							-79	
Vine St & Old Fulton Rd 2019 (TMC-009)	3							
Vine St	3	EB	0	0	0	0	0	
Vine St	3	WB	0	0	0	0	0	
Old Fulton Rd	3	NB	0	34	4	0	0	
Old Fulton Rd	3	SB	0	0	-46	0	0	
							-8	

CBD Tolling
Dumbo - Traffic Flowmap
PM Action Increment



- Legend:**
- 1 - Intersection (2019 Collected Data)
 - 7 - Intersection (Uncollected Data)
 - 100 - ATR Volume
 - 100 - Approach Volume

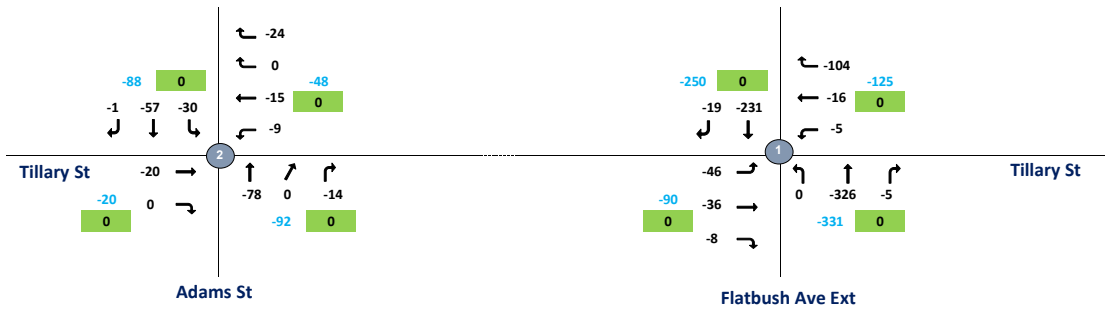

CBD Tolling
Dumbo #2 - Traffic Flowmap
PM Action Increment



- Legend:**
- 1 - Intersection (2019 Collected Data)
 - 7 - Intersection (Uncollected Data)
 - 100 - ATR Volume
 - 100 - Approach Volume

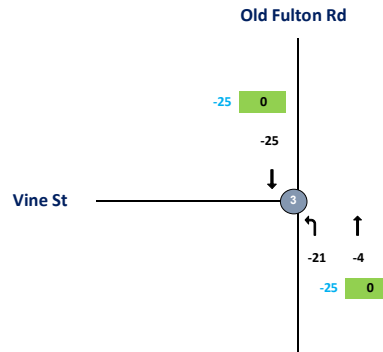

DUMBO

5:00:00 PM

Intersection	Node	Approach	Total Vehicles					
			Inbound/Outbound					
			PM Peak Hour					
			L2	L	T	R	R2	Total
Tillary St & Flatbush Ave ext 2019 (TMC-007)	1							
Tillary St	1	EB	0	-46	-36	-8	0	
Tillary St	1	WB	0	-5	-16	-104	0	
Flatbush Ave ext	1	NB	0	0	-326	-5	0	
Flatbush Ave ext	1	SB	0	0	-231	-19	0	-796
Tillary St & Adams St 2019 (TMC-008)	2							
Tillary St	2	EB	0	0	-20	0	0	
Tillary St	2	WB	0	-9	-15	0	-24	
Adams St	2	NB	0	0	-78	0	-14	
Adams St	2	SB	0	-30	-57	-1	0	-248
Vine St & Old Fulton Rd 2019 (TMC-009)	3							
Vine St	3	EB	0	0	0	0	0	
Vine St	3	WB	0	0	0	0	0	
Old Fulton Rd	3	NB	0	-21	-4	0	0	
Old Fulton Rd	3	SB	0	0	-25	0	0	-50

CBD Tolling
Dumbo - Traffic Flowmap
LN Action Increment



- Legend:**
- 1 - Intersection (2019 Collected Data)
 - 7 - Intersection (Uncollected Data)
 - 100 - ATR Volume
 - 100 - Approach Volume

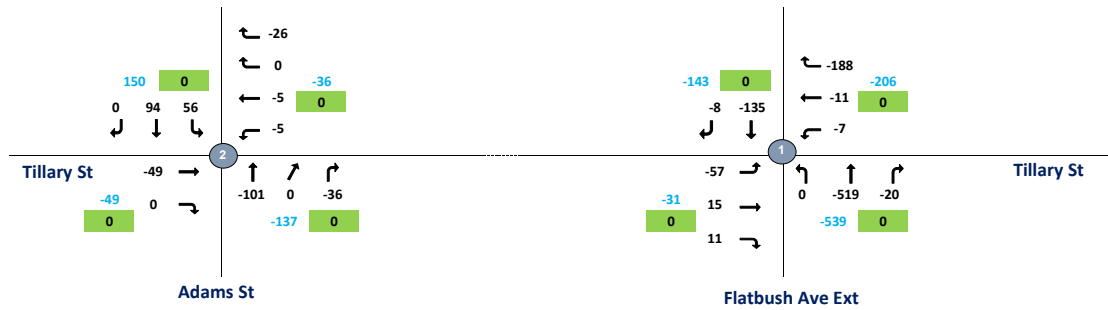

CBD Tolling
Dumbo #2 - Traffic Flowmap
LN Action Increment



- Legend:**
- 1 - Intersection (2019 Collected Data)
 - 7 - Intersection (Uncollected Data)
 - 100 - ATR Volume
 - 100 - Approach Volume

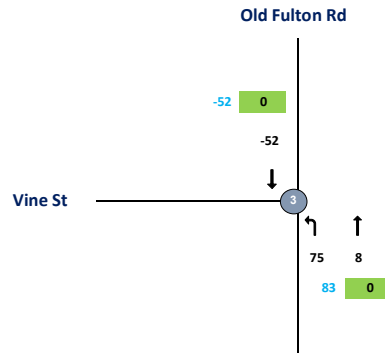

DUMBO

9:00:00 PM

Intersection	Node	Approach	Total Vehicles					
			Inbound/Outbound					
			LN Peak Hour					
			L2	L	T	R	R2	Total
Tillary St & Flatbush Ave ext 2019 (TMC-007)	1							
Tillary St	1	EB	0	-57	15	11	0	
Tillary St	1	WB	0	-7	-11	-188	0	
Flatbush Ave ext	1	NB	0	0	-519	-20	0	
Flatbush Ave ext	1	SB	0	0	-135	-8	0	-919
Tillary St & Adams St 2019 (TMC-008)	2							
Tillary St	2	EB	0	0	-49	0	0	
Tillary St	2	WB	0	-5	-5	0	-26	
Adams St	2	NB	0	0	-101	0	-36	
Adams St	2	SB	0	56	94	0	0	-72
Vine St & Old Fulton Rd 2019 (TMC-009)	3							
Vine St	3	EB	0	0	0	0	0	
Vine St	3	WB	0	0	0	0	0	
Old Fulton Rd	3	NB	0	75	8	0	0	
Old Fulton Rd	3	SB	0	0	-52	0	0	31

CBD Tolling
LIC - Traffic Flowmap #1
AM Action Increment



- Legend:**
- - Intersection (2019 Collected Data)
 - - Intersection (Uncollected Data)
 - 100 - ATR Volume
 - 100 - Approach Volume

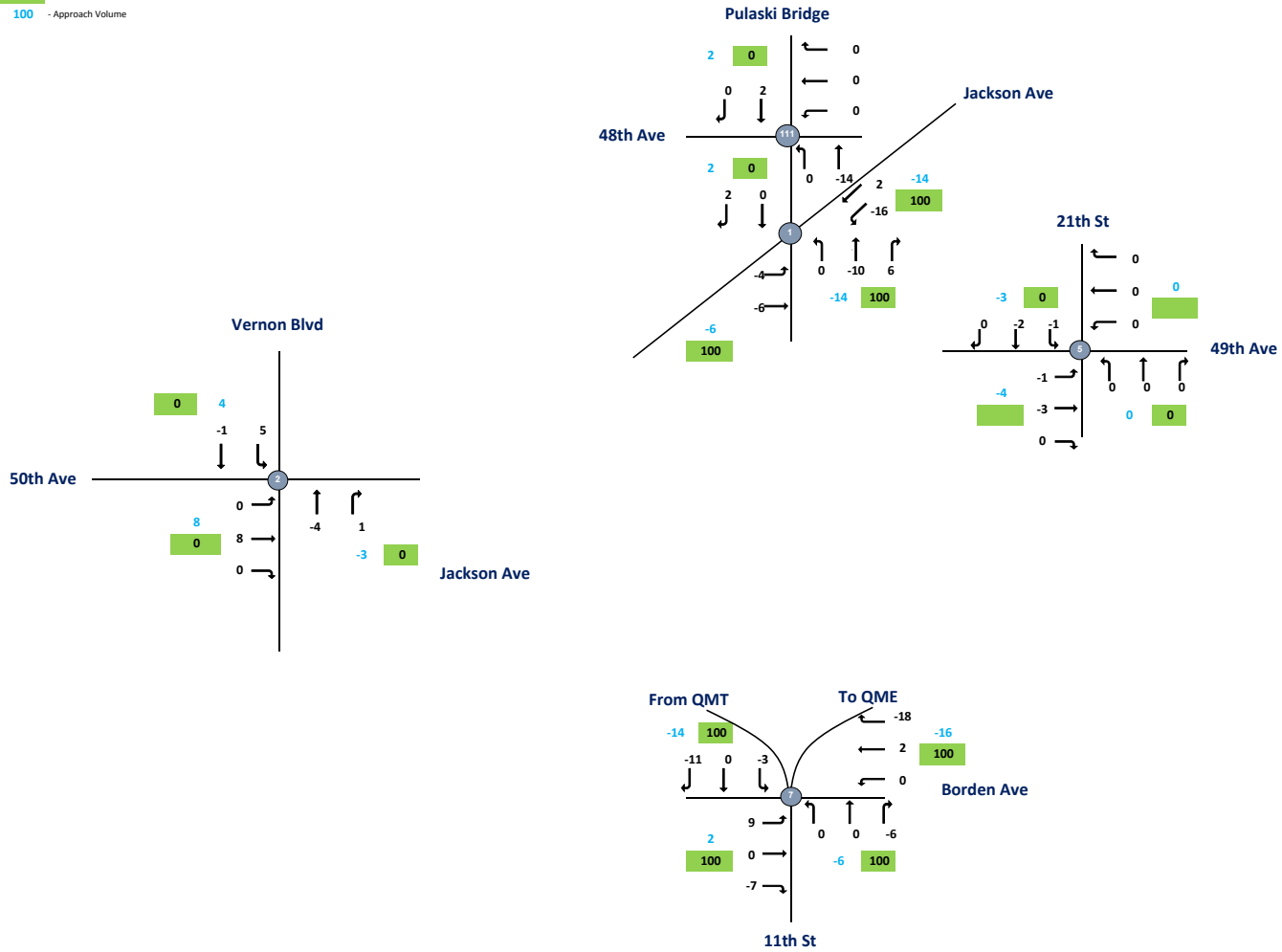

CBD Tolling
LIC - Traffic Flowmap #2
AM Action Increment



- Legend:**
- Intersection (2019 Collected Data)
 - Intersection (Uncollected Data)
 - 100 - ATR Volume
 - 100 - Approach Volume

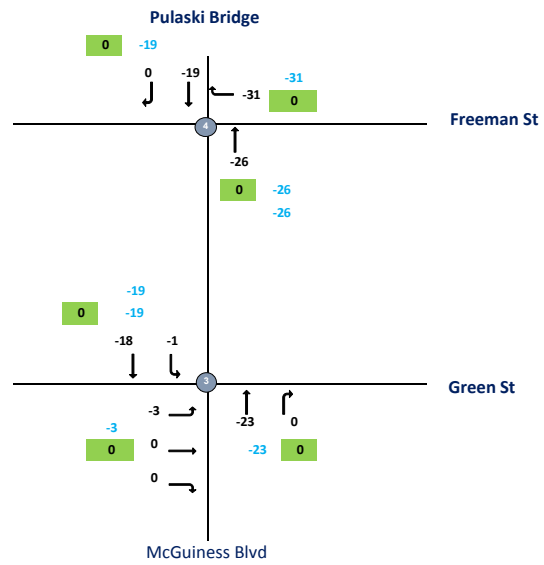

CBD Tolling
LIC - Traffic Flowmap #3
AM Action Increment



- Legend:**
- Intersection (2019 Collected Data)
 - Intersection (Uncollected Data)
 - 100 - ATR Volume
 - 100 - Approach Volume

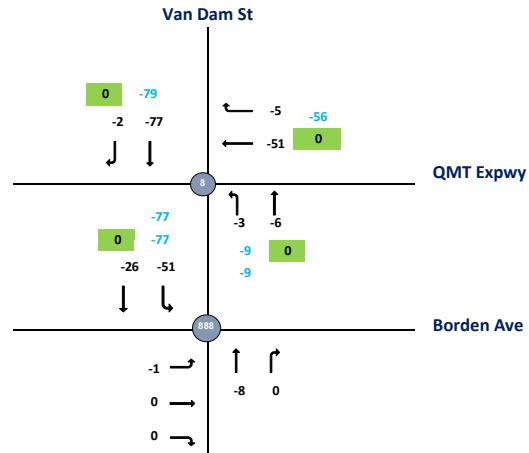

CBD Tolling
LIC - Traffic Flowmap #4
AM Action Increment



- Legend:**
- 1 - Intersection (2019 Collected Data)
 - 7 - Intersection (Uncollected Data)
 - 100 - ATR Volume
 - 100 - Approach Volume

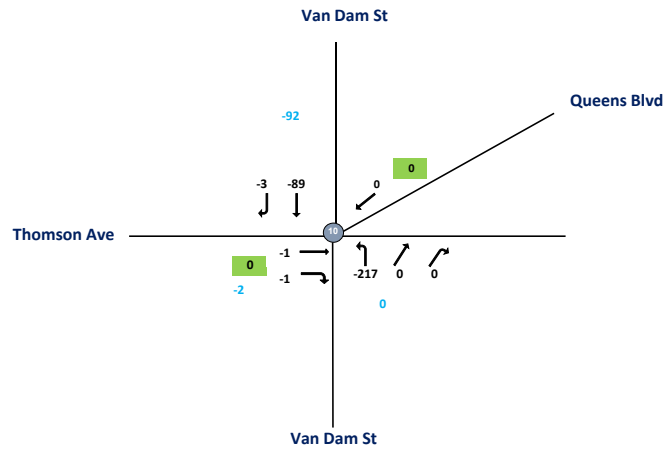
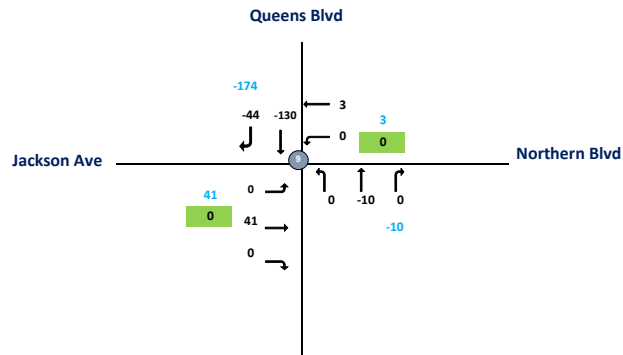

CBD Tolling
LIC - Traffic Flowmap #5
AM Action Increment



- Legend:**
- Intersection (2019 Collected Data)
 - Intersection (Uncollected Data)
 - 100 - ATR Volume
 - 100 - Approach Volume

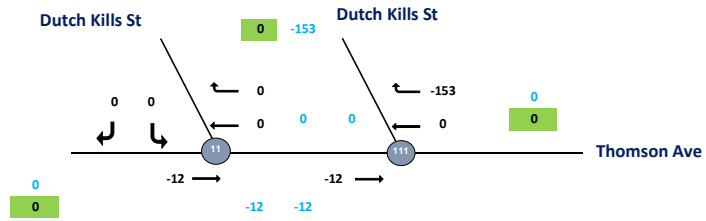

CBD Tolling
LIC - Traffic Flowmap #6
AM Action Increment



- Legend:**
- Intersection (2019 Collected Data)
 - Intersection (Uncollected Data)
 - 100 - ATR Volume
 - 100 - Approach Volume

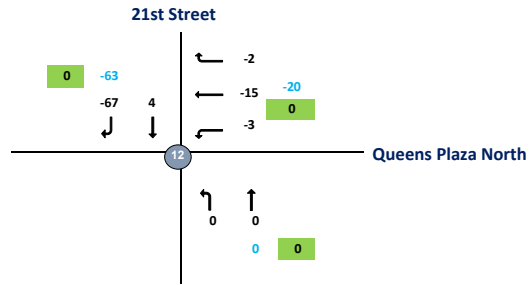

LIC

7:00:00 AM

Intersection	Node	Approach	Total Vehicles						
			Inbound/Outbound					Total	
			AM Peak Hour						
			L2	L	T	R	R2		
11th St / Pulaski Brdge & Jackson Ave 2017 --> 2019 (LIC_1_TMC-6A)	1								
Pulaski Bridge / 11th St	1	EB	0	-4	-6	0	0		
Pulaski Bridge / 11th St	1	WB	0	-16	2	0	0		
Jackson Ave	1	NB	0	0	-10	6	0		
Jackson Ave	1	SB	0	0	0	2	0		-26
11th St / 48th St 2017 --> 2019 (LIC_1_TMC-6A)	111								
11th St	111	EB	0	0	0	0	0		
11th St	111	WB	0	0	0	0	0		
48th St	111	NB	0	0	-14	0	0		
48th St	111	SB	0	0	2	0	0		-12
Vernon Blvd & 50th Ave 2019 (TMC-001)	2								
50th Ave	2	EB	0	0	8	0	0		
50th Ave	2	WB	0	0	0	0	0		
Vernon Blvd	2	NB	0	0	-4	1	0		
Vernon Blvd	2	SB	0	5	-1	0	0		9
Pulsaki Bridge & Green St 2019 (TMC-002)	3								
Green St	3	EB	0	-3	0	0	0		
Green St	3	WB	0	0	0	0	0		
Pulsaki Bridge	3	NB	0	0	-23	0	0		
Pulsaki Btridge	3	SB	0	-1	-18	0	0		-45
Pulsaki Bridge & Freeman St 2019 (TMC-003)	4								
Freeman St	4	EB	0	0	0	0	0		
Freeman St	4	WB	0	0	0	-31	0		
Pulsaki Bridge	4	NB	0	0	-26	0	0		
Pulsaki Btridge	4	SB	0	0	-19	0	0		-76
49th Ave & 21st St 2017 --> 2019 (LIC_5_TMC-6C)	5								
49th Ave	5	EB	0	-1	-3	0	0		
49th Ave	5	WB	0	0	0	0	0		
21th Ave	5	NB	0	0	0	0	0		
21th Ave	5	SB	0	-1	-2	0	0		-7
Borden Ave & 11th Street 2018 -- 2019 (LIC_7_TMC-6D)	7								
Borden Ave	7	EB	0	9	0	-7	0		
Borden Ave	7	WB	0	0	2	-18	0		
11th St	7	NB	0	0	0	-6	0		
11th St	7	SB	0	-3	0	-11	0		-34

Van Dam St & QMT Expwy (North) 2019 (TMC-004A)	8								
QMT Expwy	8	EB	0	0	0	0	0		
QMT Expwy	8	WB	0	0	-51	-5	0		
Van Dam St	8	NB	0	-3	-6	0	0		
Van Dam St	8	SB	0	0	-77	-2	0		-144
Van Dam St & QMT Expwy (South) 2019 (TMC-004B)	888								
QMT Expwy	888	EB	0	-1	0	0	0		
QMT Expwy	888	WB	0	0	0	0	0		
Van Dam St	888	NB	0	0	-8	0	0		
Van Dam St	888	SB	0	-51	-26	0	0		-86
Queens Blvd & Jackson Ave (Mainline) 2018 --> 2019 (LIC_9A_TMC-6E)	9								
Queens Blvd	9	EB	0	0	-130	-44	0		
Queens Blvd	9	WB	0	0	-10	0	0		
Jackson Ave	9	NB	0	0	41	0	0		
Jackson Ave	9	SB	0	0	3	0	0		-140
Queens Blvd & Jackson Ave (Service Rd) 2018 --> 2019 (LIC_9A_TMC-6E)	9A								
Queens Blvd	9A	EB	0	0	0	0	0		
Queens Blvd	9A	WB	0	0	0	0	0		
Jackson Ave	9A	NB	0	0	0	0	0		
Jackson Ave	9A	SB	0	0	0	0	0		0
Thompson Ave & Queens Blvd 2018 --> 2019 (LIC_10_TMC-6G)	10								
Queens Blvd	10	EB	0	0	0	-1	-1		
Queens Blvd	10	WB	0	0	0	0	0		
Thompson Ave	10	NB	0	-217	0	0	0		
Thompson Ave	10	SB	0	0	-89	-3	0		-311
Dutch Kills St & Thomson Ave (#1) 2019 (TMC-005)	11								
Thomson Ave	11	EB	0	0	-12	0	0		
Thomson Ave	11	WB	0	0	0	0	0		
Dutch Kills St	11	NB	0	0	0	0	0		
Dutch Kills St	11	SB	0	0	0	0	0		-12
Dutch Kills St & Thomson Ave (#2) 2019 (TMC-005)	1111								
Thomson Ave	1111	EB	0	0	-12	0	0		
Thomson Ave	1111	WB	0	0	0	-153	0		
Dutch Kills St	1111	NB	0	0	0	0	0		
Dutch Kills St	1111	SB	0	0	0	0	0		-165
21st Street & Queens Plaza North 2019 (TMC-006)	12								
Queens Plaza North	12	EB	0	0	0	0	0		
Queens Plaza North	12	WB	0	-3	-15	-2	0		
21st Street	12	NB	0	0	0	0	0		
21st Street	12	SB	0	0	4	-67	0		-83

CBD Tolling
LIC - Traffic Flowmap #1
MD Action Increment



- Legend:**
- 1 - Intersection (2019 Collected Data)
 - 7 - Intersection (Uncollected Data)
 - 100 - ATR Volume
 - 100 - Approach Volume

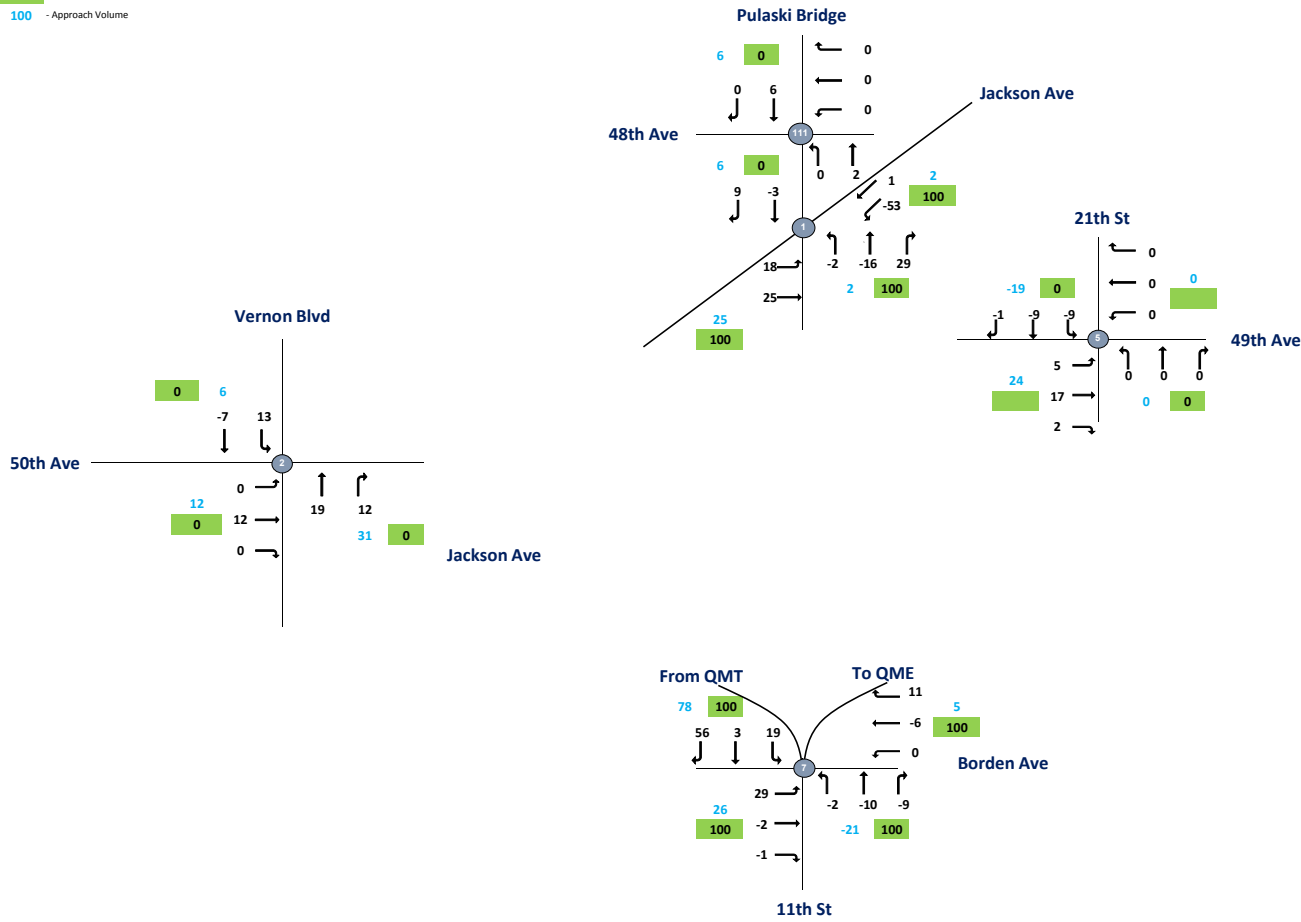

CBD Tolling
LIC - Traffic Flowmap #2
MD Action Increment



- Legend:**
- Intersection (2019 Collected Data)
 - Intersection (Uncollected Data)
 - 100 - ATR Volume
 - 100 - Approach Volume

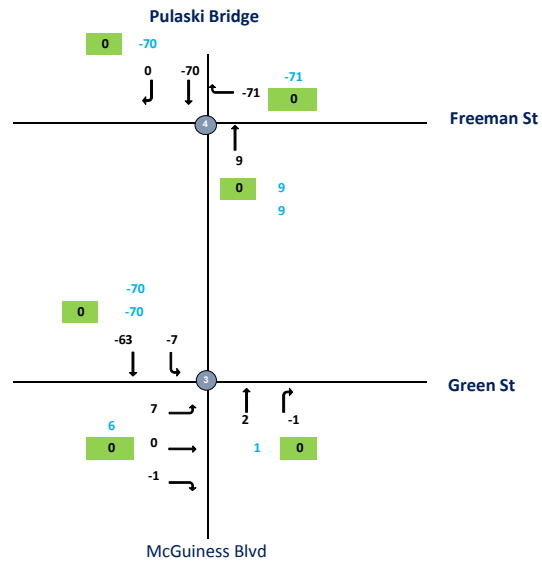

CBD Tolling
LIC - Traffic Flowmap #3
MD Action Increment



- Legend:**
- 1 - Intersection (2019 Collected Data)
 - 7 - Intersection (Uncollected Data)
 - 100 - ATR Volume
 - 100 - Approach Volume

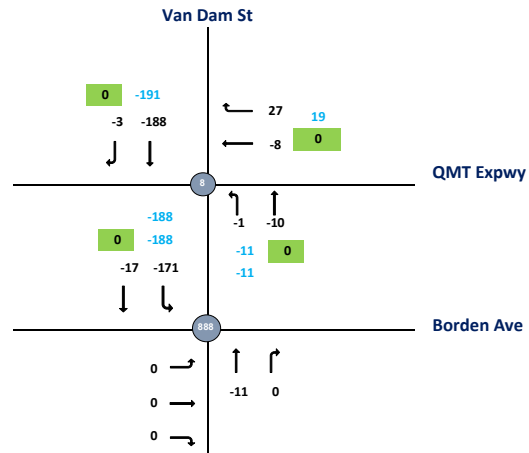

CBD Tolling
LIC - Traffic Flowmap #4
MD Action Increment



- Legend:**
- 1 - Intersection (2019 Collected Data)
 - 7 - Intersection (Uncollected Data)
 - 100 - ATR Volume
 - 100 - Approach Volume

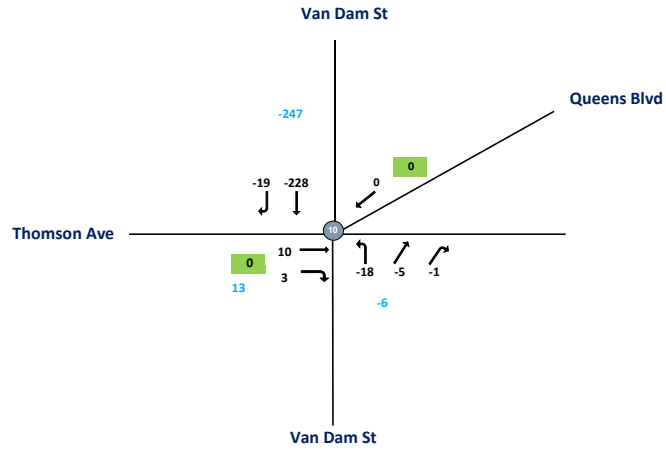
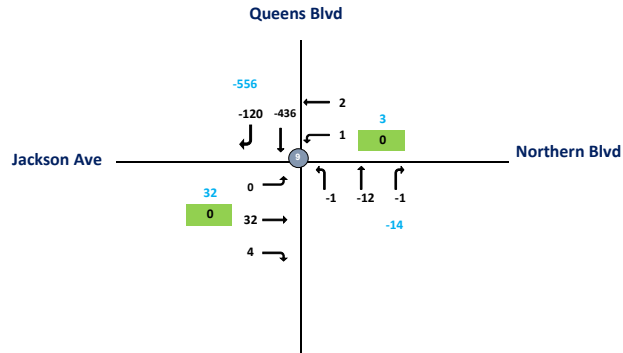

CBD Tolling
LIC - Traffic Flowmap #5
MD Action Increment



- Legend:**
- Intersection (2019 Collected Data)
 - Intersection (Uncollected Data)
 - 100 - ATR Volume
 - 100 - Approach Volume

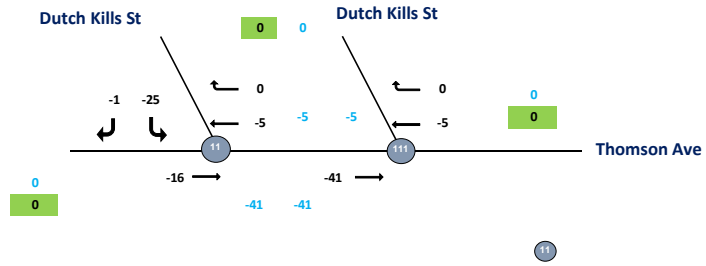

CBD Tolling
LIC - Traffic Flowmap #6
MD Action Increment



- Legend:**
- Intersection (2019 Collected Data)
 - Intersection (Uncollected Data)
 - 100 - ATR Volume
 - 100 - Approach Volume

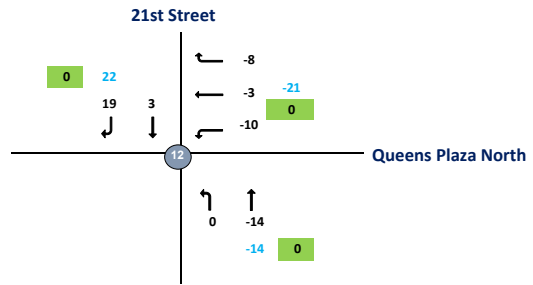

LIC

1:00:00 PM

Intersection	Node	Approach	Total Vehicles						
			Inbound/Outbound					Total	
			MD Peak Hour						
			L2	L	T	R	R2		
11th St / Pulaski Bdrge & Jackson Ave 2017 --> 2019 (LIC_1_TMC-6A)	1								
Pulaski Bridge / 11th St	1	EB	0	18	25	0	0		
Pulaski Bridge / 11th St	1	WB	0	-53	1	0	0		
Jackson Ave	1	NB	0	-2	-16	29	0		
Jackson Ave	1	SB	0	0	-3	9	0		8
11th St / 48th St 2017 --> 2019 (LIC_1_TMC-6A)	111								
11th St	111	EB	0	0	0	0	0		
11th St	111	WB	0	0	0	0	0		
48th St	111	NB	0	0	2	0	0		
48th St	111	SB	0	0	6	0	0		8
Vernon Blvd & 50th Ave 2019 (TMC-001)	2								
50th Ave	2	EB	0	0	12	0	0		
50th Ave	2	WB	0	0	0	0	0		
Vernon Blvd	2	NB	0	0	19	12	0		
Vernon Blvd	2	SB	0	13	-7	0	0		49
Pulsaki Bridge & Green St 2019 (TMC-002)	3								
Green St	3	EB	0	7	0	-1	0		
Green St	3	WB	0	0	0	0	0		
Pulsaki Bridge	3	NB	0	0	2	-1	0		
Pulsaki Btridge	3	SB	0	-7	-63	0	0		-63
Pulsaki Bridge & Freeman St 2019 (TMC-003)	4								
Freeman St	4	EB	0	0	0	0	0		
Freeman St	4	WB	0	0	0	-71	0		
Pulsaki Bridge	4	NB	0	0	9	0	0		
Pulsaki Btridge	4	SB	0	0	-70	0	0		-132
49th Ave & 21st St 2017 --> 2019 (LIC_5_TMC-6C)	5								
49th Ave	5	EB	0	5	17	2	0		
49th Ave	5	WB	0	0	0	0	0		
21th Ave	5	NB	0	0	0	0	0		
21th Ave	5	SB	0	-9	-9	-1	0		5
Borden Ave & 11th Street 2018 -- 2019 (LIC_7_TMC-6D)	7								
Borden Ave	7	EB	0	29	-2	-1	0		
Borden Ave	7	WB	0	0	-6	11	0		
11th St	7	NB	0	-2	-10	-9	0		
11th St	7	SB	0	19	3	56	0		88

Van Dam St & QMT Expwy (North) 2019 (TMC-004A)	8								
QMT Expwy	8	EB	0	0	0	0	0		
QMT Expwy	8	WB	0	0	-8	27	0		
Van Dam St	8	NB	0	-1	-10	0	0		
Van Dam St	8	SB	0	0	-188	-3	0		-183
Van Dam St & QMT Expwy (South) 2019 (TMC-004B)	888								
QMT Expwy	888	EB	0	0	0	0	0		
QMT Expwy	888	WB	0	0	0	0	0		
Van Dam St	888	NB	0	0	-11	0	0		
Van Dam St	888	SB	0	-171	-17	0	0		-199
Queens Blvd & Jackson Ave (Mainline) 2018 --> 2019 (LIC_9A_TMC-6E)	9								
Queens Blvd	9	EB	0	0	-436	-120	0		
Queens Blvd	9	WB	0	-1	-12	-1	0		
Jackson Ave	9	NB	0	0	32	4	0		
Jackson Ave	9	SB	0	1	2	0	0		-531
Queens Blvd & Jackson Ave (Service Rd) 2018 --> 2019 (LIC_9A_TMC-6E)	9A								
Queens Blvd	9A	EB	0	0	0	0	0		
Queens Blvd	9A	WB	0	0	0	0	0		
Jackson Ave	9A	NB	0	0	0	0	0		
Jackson Ave	9A	SB	0	0	0	0	0		0
Thompson Ave & Queens Blvd 2018 --> 2019 (LIC_10_TMC-6G)	10								
Queens Blvd	10	EB	0	0	0	10	3		
Queens Blvd	10	WB	0	0	0	0	0		
Thompson Ave	10	NB	0	-18	-5	0	-1		
Thompson Ave	10	SB	0	0	-228	-19	0		-258
Dutch Kills St & Thomson Ave (#1) 2019 (TMC-005)	11								
Thomson Ave	11	EB	0	0	-16	0	0		
Thomson Ave	11	WB	0	0	-5	0	0		
Dutch Kills St	11	NB	0	0	0	0	0		
Dutch Kills St	11	SB	0	-25	0	-1	0		-47
Dutch Kills St & Thomson Ave (#2) 2019 (TMC-005)	1111								
Thomson Ave	1111	EB	0	0	-41	0	0		
Thomson Ave	1111	WB	0	0	-5	0	0		
Dutch Kills St	1111	NB	0	0	0	0	0		
Dutch Kills St	1111	SB	0	0	0	0	0		-46
21st Street & Queens Plaza North 2019 (TMC-006)	12								
Queens Plaza North	12	EB	0	0	0	0	0		
Queens Plaza North	12	WB	0	-10	-3	-8	0		
21st Street	12	NB	0	0	-14	0	0		
21st Street	12	SB	0	0	3	19	0		-13

CBD Tolling
LIC - Traffic Flowmap #1
PM Action Increment



- Legend:**
- - Intersection (2019 Collected Data)
 - - Intersection (Uncollected Data)
 - 100 - ATR Volume
 - 100 - Approach Volume

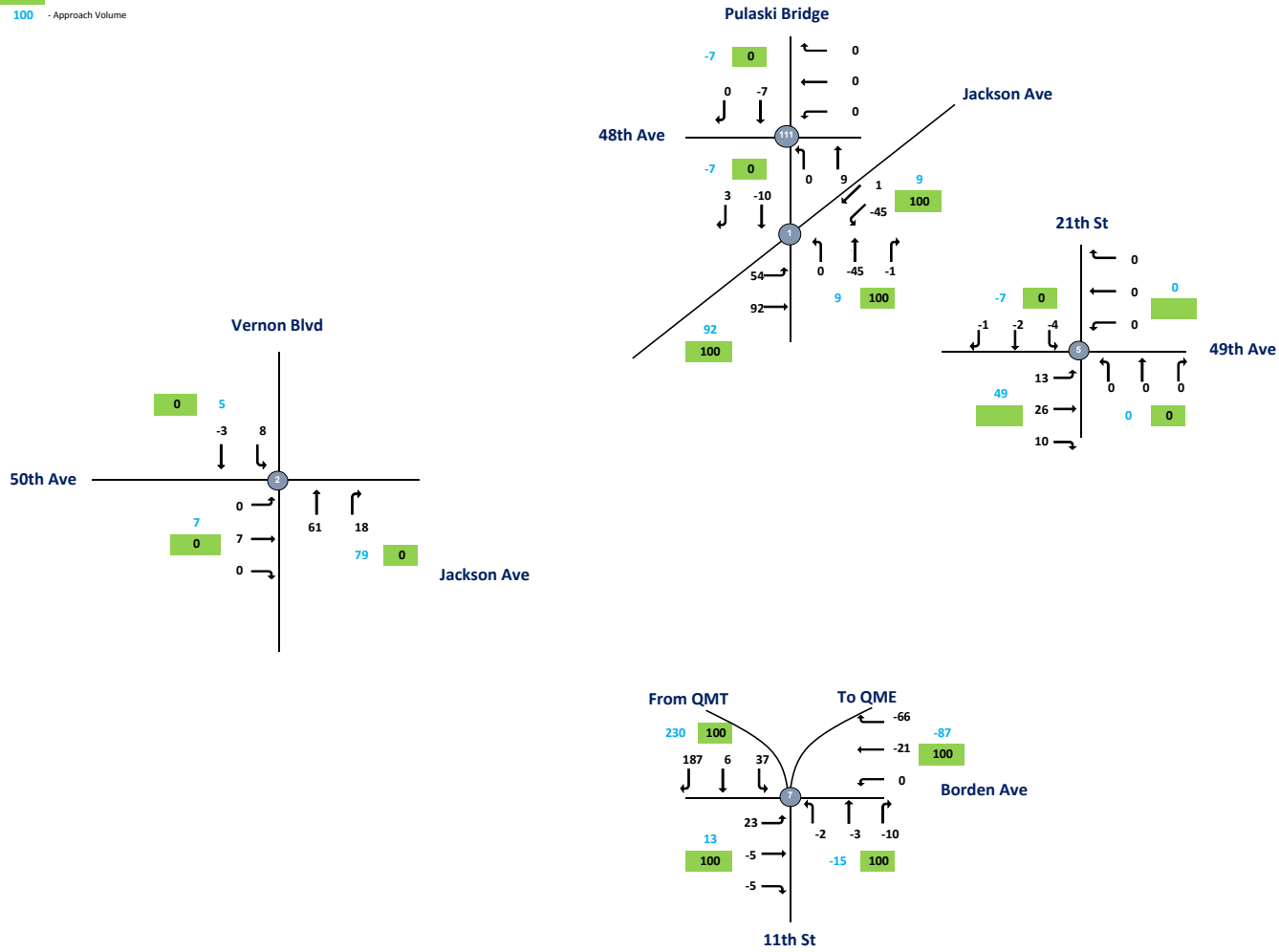

CBD Tolling
LIC - Traffic Flowmap #2
PM Action Increment



- Legend:**
- Intersection (2019 Collected Data)
 - Intersection (Uncollected Data)
 - 100 - ATR Volume
 - 100 - Approach Volume

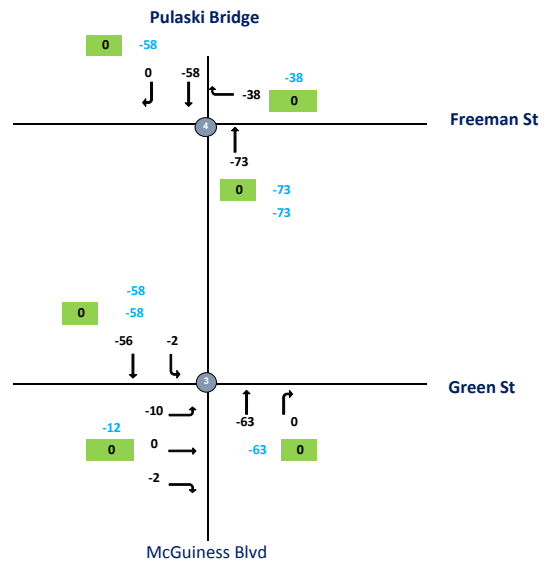

CBD Tolling
LIC - Traffic Flowmap #3
PM Action Increment



- Legend:**
- Intersection (2019 Collected Data)
 - Intersection (Uncollected Data)
 - 100 - ATR Volume
 - 100 - Approach Volume

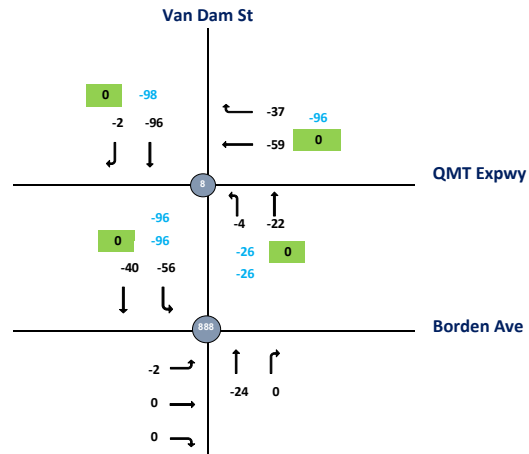

CBD Tolling
LIC - Traffic Flowmap #4
PM Action Increment



- Legend:**
- 1 - Intersection (2019 Collected Data)
 - 7 - Intersection (Uncollected Data)
 - 100 - ATR Volume
 - 100 - Approach Volume

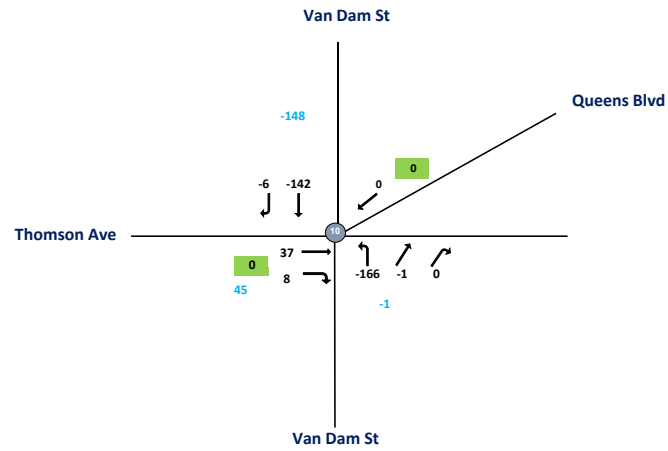
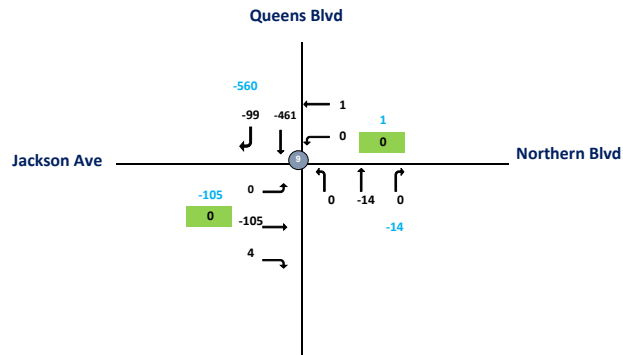

CBD Tolling
LIC - Traffic Flowmap #5
PM Action Increment



- Legend:**
- Intersection (2019 Collected Data)
 - Intersection (Uncollected Data)
 - 100 - ATR Volume
 - 100 - Approach Volume

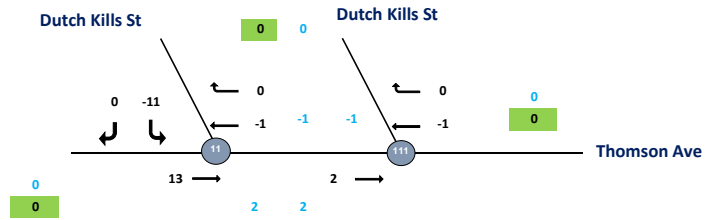

CBD Tolling
LIC - Traffic Flowmap #6
PM Action Increment



- Legend:**
- Intersection (2019 Collected Data)
 - Intersection (Uncollected Data)
 - 100 - ATR Volume
 - 100 - Approach Volume

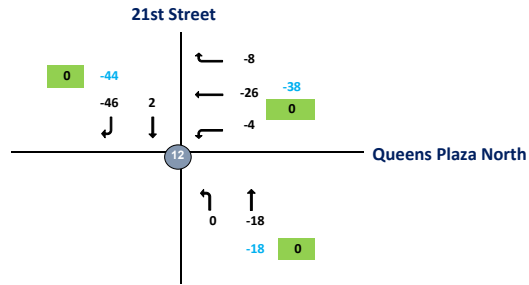

LIC

5:00:00 PM

Intersection	Node	Approach	Total Vehicles					
			Inbound/Outbound					Total
			L2	L	T	R	R2	
11th St / Pulaski Brdge & Jackson Ave 2017 --> 2019 (LIC_1_TMC-6A)	1							
Pulaski Bridge / 11th St	1	EB	0	54	92	0	0	
Pulaski Bridge / 11th St	1	WB	0	-45	1	0	0	
Jackson Ave	1	NB	0	0	-45	-1	0	
Jackson Ave	1	SB	0	0	-10	3	0	
							49	
11th St / 48th St 2017 --> 2019 (LIC_1_TMC-6A)	111							
11th St	111	EB	0	0	0	0	0	
11th St	111	WB	0	0	0	0	0	
48th St	111	NB	0	0	9	0	0	
48th St	111	SB	0	0	-7	0	0	
							2	
Vernon Blvd & 50th Ave 2019 (TMC-001)	2							
50th Ave	2	EB	0	0	7	0	0	
50th Ave	2	WB	0	0	0	0	0	
Vernon Blvd	2	NB	0	0	61	18	0	
Vernon Blvd	2	SB	0	8	-3	0	0	
							91	
Pulsaki Bridge & Green St 2019 (TMC-002)	3							
Green St	3	EB	0	-10	0	-2	0	
Green St	3	WB	0	0	0	0	0	
Pulsaki Bridge	3	NB	0	0	-63	0	0	
Pulsaki Btridge	3	SB	0	-2	-56	0	0	
							-133	
Pulsaki Bridge & Freeman St 2019 (TMC-003)	4							
Freeman St	4	EB	0	0	0	0	0	
Freeman St	4	WB	0	0	0	-38	0	
Pulsaki Bridge	4	NB	0	0	-73	0	0	
Pulsaki Btridge	4	SB	0	0	-58	0	0	
							-169	
49th Ave & 21st St 2017 --> 2019 (LIC_5_TMC-6C)	5							
49th Ave	5	EB	0	13	26	10	0	
49th Ave	5	WB	0	0	0	0	0	
21th Ave	5	NB	0	0	0	0	0	
21th Ave	5	SB	0	-4	-2	-1	0	
							42	
Borden Ave & 11th Street 2018 -- 2019 (LIC_7_TMC-6D)	7							
Borden Ave	7	EB	0	23	-5	-5	0	
Borden Ave	7	WB	0	0	-21	-66	0	
11th St	7	NB	0	-2	-3	-10	0	
11th St	7	SB	0	37	6	187	0	
							141	

Van Dam St & QMT Expwy (North) 2019 (TMC-004A)	8								
QMT Expwy	8	EB	0	0	0	0	0		
QMT Expwy	8	WB	0	0	-59	-37	0		
Van Dam St	8	NB	0	-4	-22	0	0		
Van Dam St	8	SB	0	0	-96	-2	0		-220
Van Dam St & QMT Expwy (South) 2019 (TMC-004B)	888								
QMT Expwy	888	EB	0	-2	0	0	0		
QMT Expwy	888	WB	0	0	0	0	0		
Van Dam St	888	NB	0	0	-24	0	0		
Van Dam St	888	SB	0	-56	-40	0	0		-122
Queens Blvd & Jackson Ave (Mainline) 2018 --> 2019 (LIC_9A_TMC-6E)	9								
Queens Blvd	9	EB	0	0	-461	-99	0		
Queens Blvd	9	WB	0	0	-14	0	0		
Jackson Ave	9	NB	0	0	-105	4	0		
Jackson Ave	9	SB	0	0	1	0	0		-674
Queens Blvd & Jackson Ave (Service Rd) 2018 --> 2019 (LIC_9A_TMC-6E)	9A								
Queens Blvd	9A	EB	0	0	0	0	0		
Queens Blvd	9A	WB	0	0	0	0	0		
Jackson Ave	9A	NB	0	0	0	0	0		
Jackson Ave	9A	SB	0	0	0	0	0		0
Thompson Ave & Queens Blvd 2018 --> 2019 (LIC_10_TMC-6G)	10								
Queens Blvd	10	EB	0	0	0	37	8		
Queens Blvd	10	WB	0	0	0	0	0		
Thompson Ave	10	NB	0	-166	-1	0	0		
Thompson Ave	10	SB	0	0	-142	-6	0		-270
Dutch Kills St & Thomson Ave (#1) 2019 (TMC-005)	11								
Thomson Ave	11	EB	0	0	13	0	0		
Thomson Ave	11	WB	0	0	-1	0	0		
Dutch Kills St	11	NB	0	0	0	0	0		
Dutch Kills St	11	SB	0	-11	0	0	0		1
Dutch Kills St & Thomson Ave (#2) 2019 (TMC-005)	1111								
Thomson Ave	1111	EB	0	0	2	0	0		
Thomson Ave	1111	WB	0	0	-1	0	0		
Dutch Kills St	1111	NB	0	0	0	0	0		
Dutch Kills St	1111	SB	0	0	0	0	0		1
21st Street & Queens Plaza North 2019 (TMC-006)	12								
Queens Plaza North	12	EB	0	0	0	0	0		
Queens Plaza North	12	WB	0	-4	-26	-8	0		
21st Street	12	NB	0	0	-18	0	0		
21st Street	12	SB	0	0	2	-46	0		-100

CBD Tolling
LM - Traffic Flowmap #1
AM Action Increment



- Legend:**
- 1 - Intersection (2019 Collected Data)
 - 7 - Intersection (Uncollected Data)
 - 100 - ATR Volume
 - 100 - Approach Volume

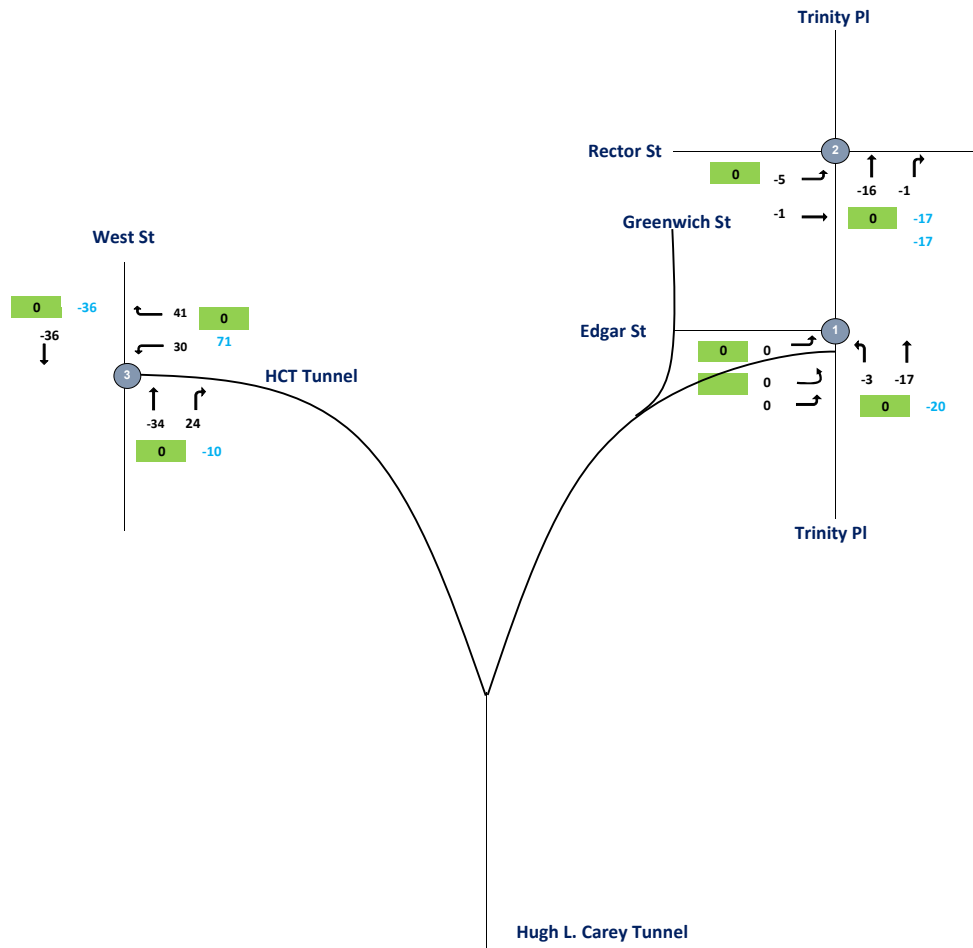

CBD Tolling
LM - Traffic Flowmap #2
AM Action Increment

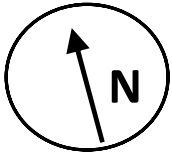

Legend:

1 - Intersection (2019 Collected Data)

7 - Intersection (Uncollected Data)

100 - ATR Volume

100 - Approach Volume

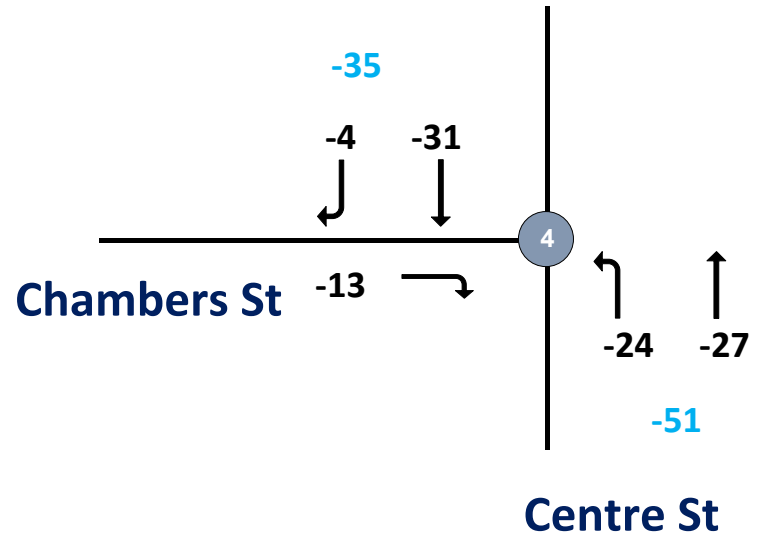

CBD Tolling
LM - Traffic Flowmap #3
AM Action Increment



- Legend:**
- Intersection (2019 Collected Data)
 - Intersection (Uncollected Data)
 - 100 - ATR Volume
 - 100 - Approach Volume

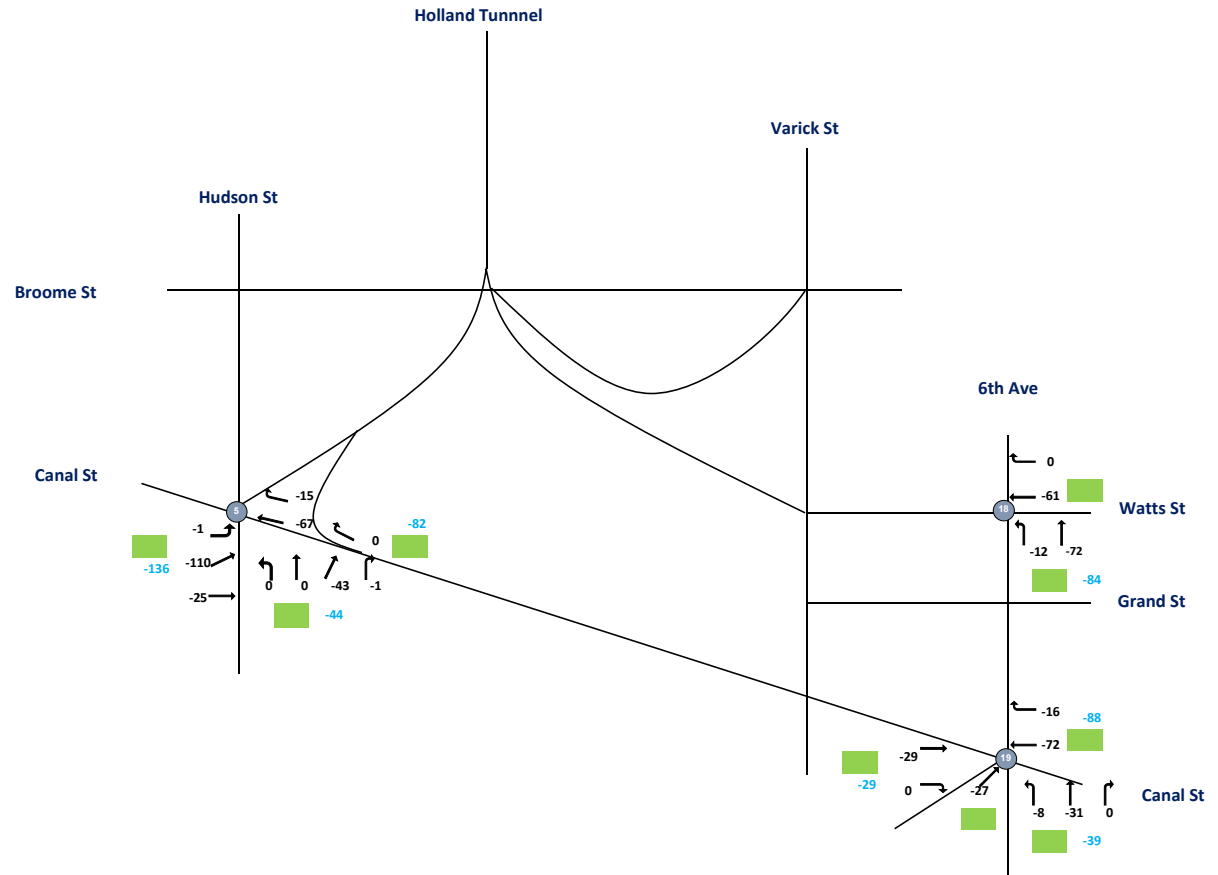

CBD Tolling
LM - Traffic Flowmap #4
AM Action Increment



- Legend:
- ① - Intersection (2019 Collected Data)
 - ② - Intersection (Uncollected Data)
 - 100 - ATR Volume
 - 100 - Approach Volume

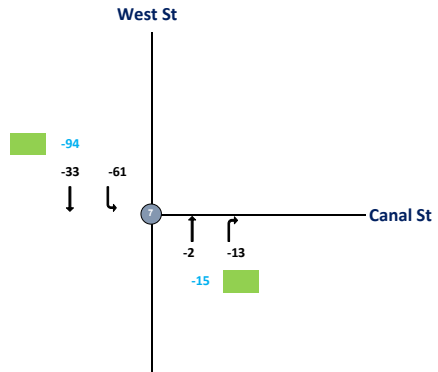

CBD Tolling
LM - Traffic Flowmap #5
AM Action Increment



- Legend:**
- Intersection (2019 Collected Data)
 - Intersection (Uncollected Data)
 - ATR Volume
 - Approach Volume

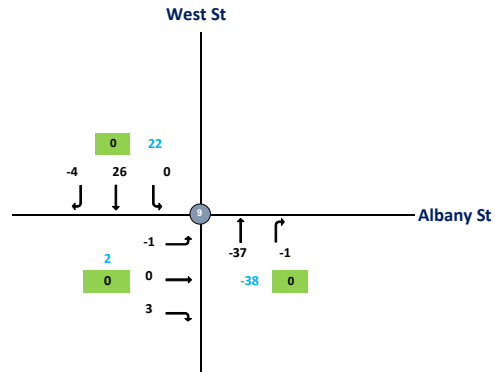

CBD Tolling
LM - Traffic Flowmap #6
AM Action Increment



- Legend:**
- 1 - Intersection (2019 Collected Data)
 - 7 - Intersection (Uncollected Data)
 - 100 - ATR Volume
 - 100 - Approach Volume
 - ↯ - Illegal movement

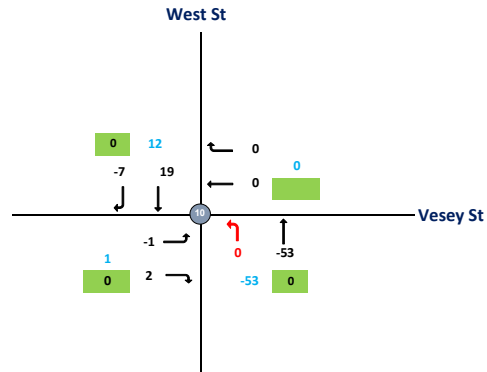

CBD Tolling
LM - Traffic Flowmap #7
AM Action Increment



- Legend:**
- 1 - Intersection (2019 Collected Data)
 - 7 - Intersection (Uncollected Data)
 - 100 - ATR Volume
 - 100 - Approach Volume

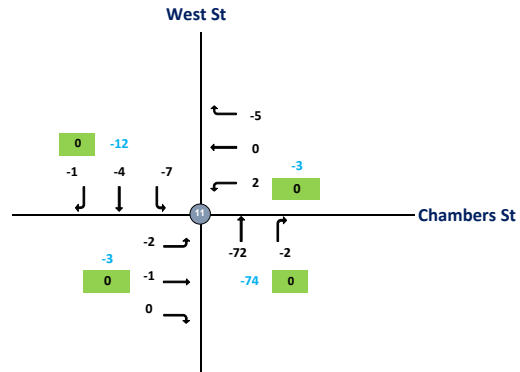

CBD Tolling
LM - Traffic Flowmap #8
AM Action Increment



- Legend:**
- Intersection (2019 Collected Data)
 - Intersection (Uncollected Data)
 - ATR Volume
 - Approach Volume

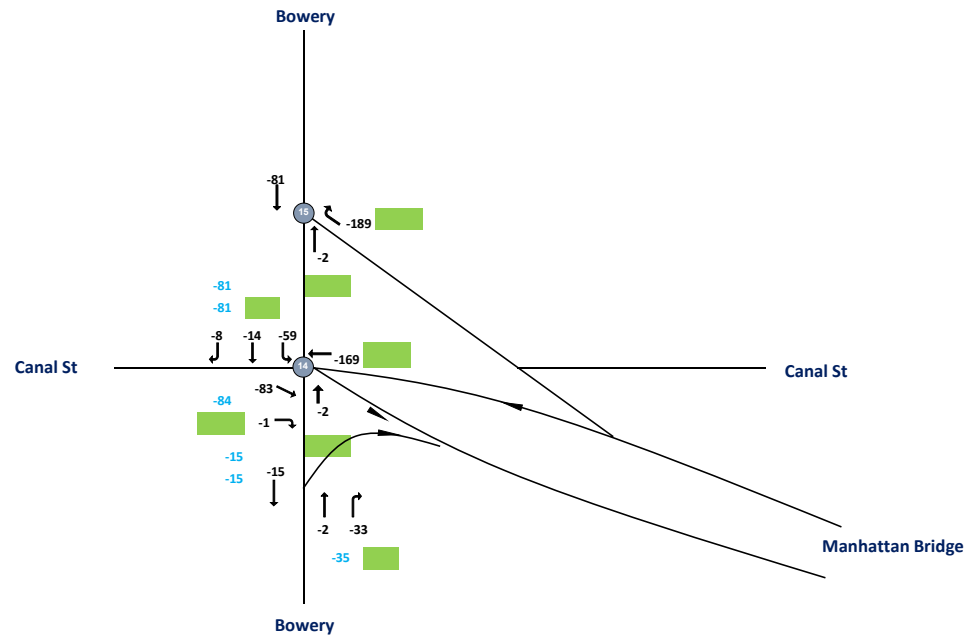

Intersection	Node	Approach	Balanced With-Action Increment					
			Inbound/Outbound					
			AM Peak Hour					
			L2	L	T	R	R2	Total
Edgar St. and Trinity Pl. 2019 (TMC-010)	1							
Edgar St.	1	EB	0	0	0	0	0	
478 Exit Ramp.	1	NE	0	0	0	0	0	
Trinity Pl.	1	NB	0	-3	-17	0	0	
Trinity Pl.	1	SB	0	0	0	0	0	-20
Rector St. and Trinity Pl. 2019 (TMC-011)	2							
Rector St.	2	EB	0	-5	-1	0	0	
Rector St.	2	WB	0	0	0	0	0	
Trinity Pl.	2	NB	0	0	-16	-1	0	
Trinity Pl.	2	SB	0	0	0	0	0	-23
West St. and HCT Exit. 2019 (TMC-012)	3							
-	3	EB	0	0	0	0	0	
HCT Exit.	3	WB	0	30	0	0	0	
West St.	3	NB	0	0	-34	0	24	
West St.	3	SB	0	0	-36	0	0	-16
West St. and HCT Exit. 2019 (TMC-012)	333							
W. Thams St.	333	EB	0	0	0	0	0	
HCT Exit.	333	WB	0	0	0	41	0	
West St.	333	NB	0	0	-34	0	0	
West St.	333	SB	0	0	-36	0	0	-29
Chambers St. and Centre St. 2018	4							
Chambers St.	4	EB	0	0	0	-13	0	
-	4	WB	0	0	0	0	0	
Centre St.	4	NB	0	-24	-27	0	0	
Centre St.	4	SB	0	0	-31	-4	0	-99
Hudson St. and Canal St. 2018	5							
Canal St.	5	EB	-1	-110	-25	0	0	
Canal St.	5	WB	0	0	-67	-15	0	
Hudson St.	5	NB	0	0	0	-43	-1	
Hudson St.	5	SB	0	0	0	0	0	-262

Hudson St. and Canal St.								
2018	555							
Canal St.	555	EB	0	0	-26	0	0	
Canal St.	555	WB	0	0	-82	0	0	
Hudson St.	555	NB	0	0	0	0	0	
Hudson St.	555	SB	0	0	0	0	0	-108
West St. and Canal St N.								
2018	7							
Canal St N.	7	EB	0	0	0	0	0	
-	7	WB	0	0	0	0	0	
West St.	7	NB	0	0	-2	-13	0	
West St.	7	SB	0	-61	-33	0	0	-109
West St. and Canal St S.								
2018	777							
-	777	EB	0	0	0	0	0	
Canal St S.	777	WB	0	0	0	0	0	
West St.	777	NB	0	0	-2	0	0	
West St.	777	SB	0	0	-94	0	0	-96
West St. and Albany St.								
2019 (TMC-013)	9							
Albany St.	9	EB	0	-1	0	3	0	
-	9	WB	0	0	0	0	0	
West St.	9	NB	0	0	-37	-1	0	
West St.	9	SB	0	0	26	-4	0	-14
West St. and Vesey St.								
2019 (TMC-014)	10							
Vesey St.	10	EB	0	-1	0	2	0	
Vesey St.	10	WB	0	0	0	0	0	
West St.	10	NB	0	0	-53	0	0	
West St.	10	SB	0	0	19	-7	0	-20
West St. and Chambers St.								
2019 (TMC-015)	11							
Chambers St.	11	EB	0	-2	-1	0	0	
Chambers St.	11	WB	0	2	0	-5	0	
West St.	11	NB	0	0	-72	-2	0	
West St.	11	SB	0	-7	-4	-1	0	-92

Bowey and Canal St./Manhattan Bridge Off-Ramp								
2018	14							
Canal St.	14	EB	0	0	-83	-1	0	
Manhattan Bridge Off-Ramp	14	WB	0	0	-169	0	0	
Bowey	14	NB	0	0	-2	-33	0	
Bowey	14	SB	0	-59	-14	-8	0	-369
Bowey and Manhattan Bridge Off-Ramp								
2018	15							
	15	EB	0	0	0	0	0	
Manhattan Bridge Off-Ramp	15	WB	0	0	0	-189	0	
Bowey	15	NB	0	0	-2	0	0	
Bowey	15	SB	0	0	-81	0	0	-272
6th Ave. and Watts St								
2018	18							
Watts St	18	EB	0	0	0	0	0	
Watts St	18	WB	0	0	-61	0	0	
6th Ave.	18	NB	0	-12	-72	0	0	
6th Ave.	18	SB	0	0	0	0	0	-145
6th Ave. and Canal St.								
2018	19							
Canal St.	19	EB	0	0	-29	0	0	
Canal St.	19	WB	0	0	-72	-16	0	
6th Ave.	19	NB	0	-8	-31	0	0	
Laight St.	19	NE	0	0	0	-27	0	-183

CBD Tolling
LM - Traffic Flowmap #1
MD Action Increment



- Legend:**
- 1 - Intersection (2019 Collected Data)
 - 7 - Intersection (Uncollected Data)
 - 100 - ATR Volume
 - 100 - Approach Volume

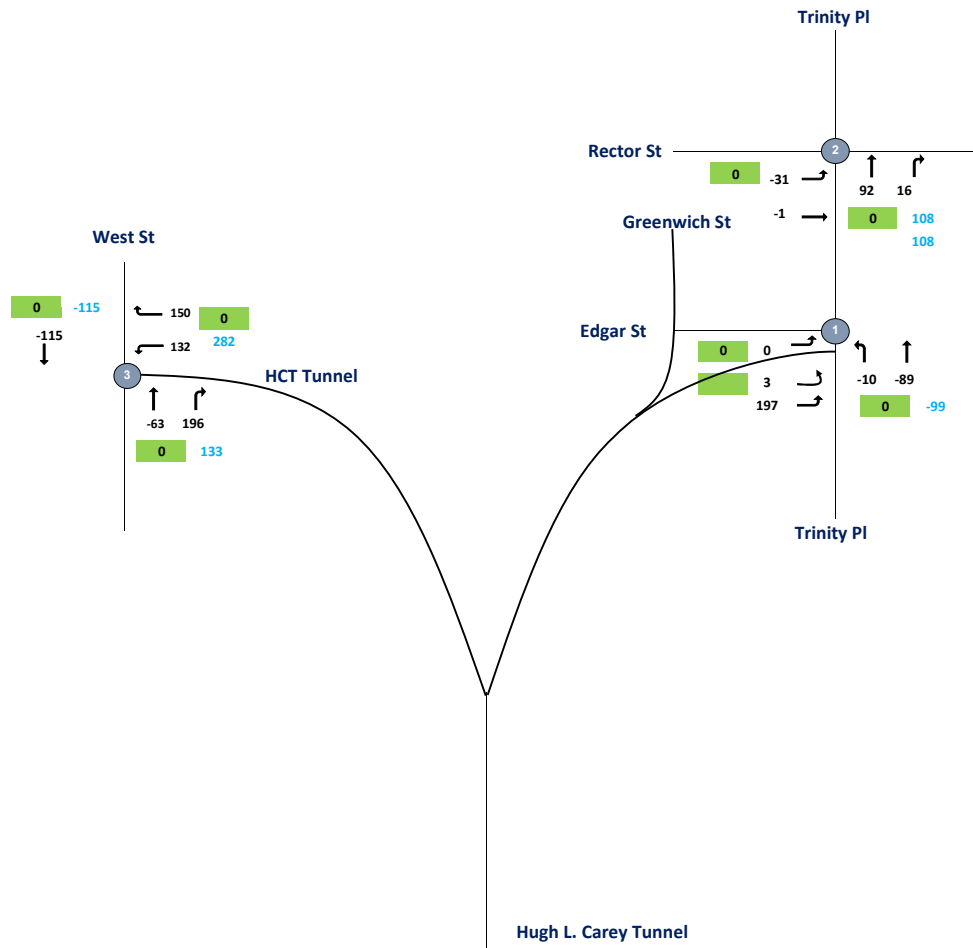

CBD Tolling
LM - Traffic Flowmap #2
MD Action Increment

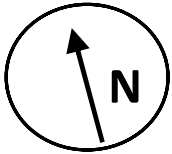

Legend:

1 - Intersection (2019 Collected Data)

7 - Intersection (Uncollected Data)

100 - ATR Volume

100 - Approach Volume

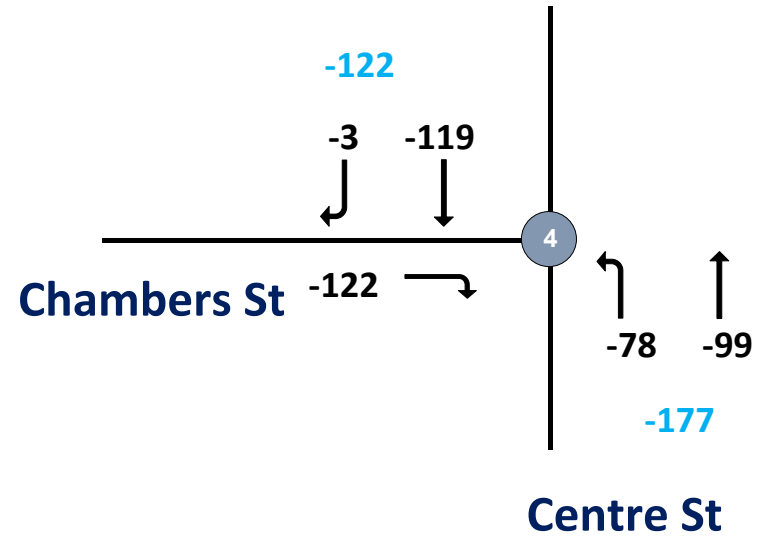

CBD Tolling
LM - Traffic Flowmap #3
MD Action Increment



- Legend:**
- Intersection (2019 Collected Data)
 - Intersection (Uncollected Data)
 - 100 - ATR Volume
 - 100 - Approach Volume

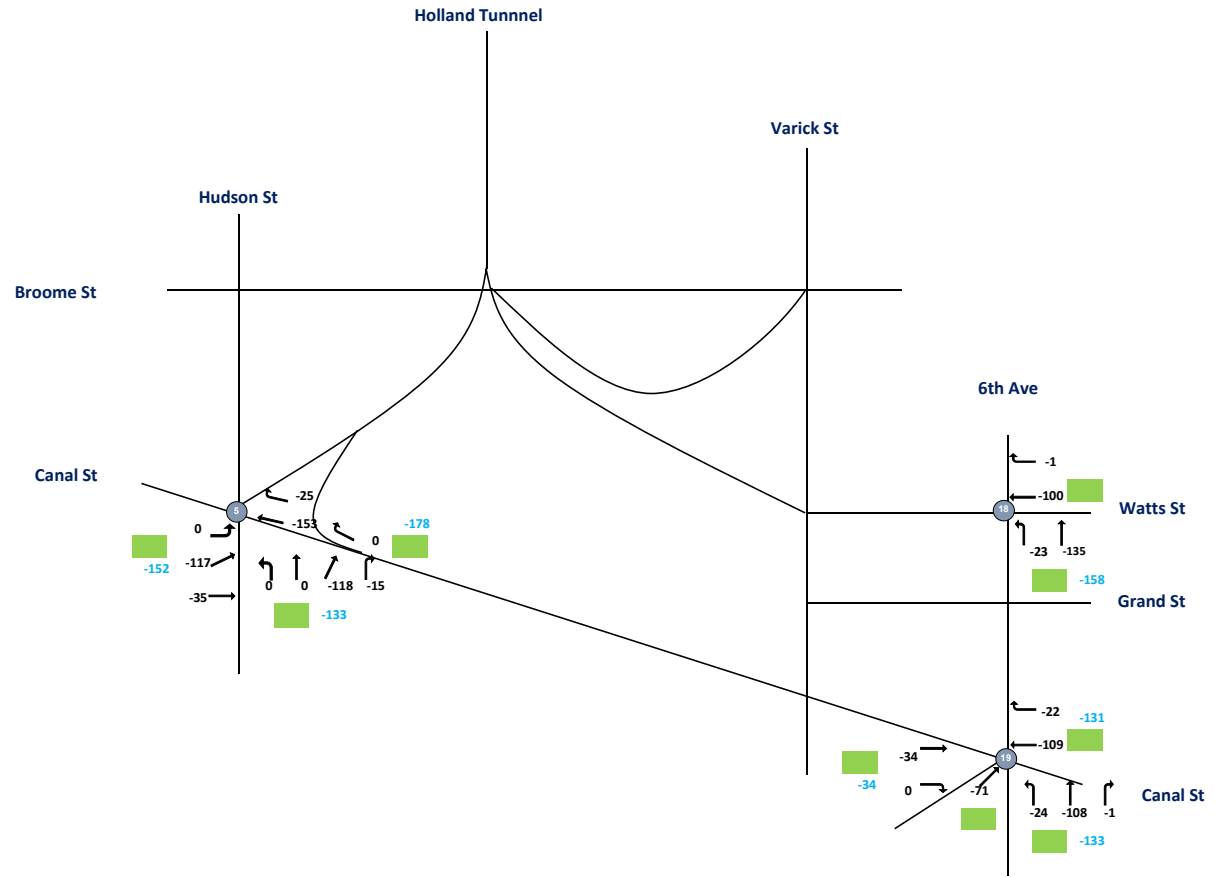

CBD Tolling
LM - Traffic Flowmap #4
MD Action Increment



- Legend:
- ① - Intersection (2019 Collected Data)
 - ② - Intersection (Uncollected Data)
 - 100 - ATR Volume
 - 100 - Approach Volume

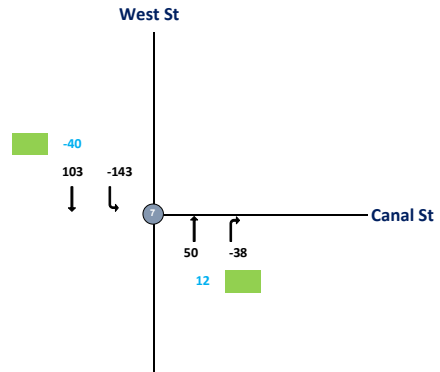

CBD Tolling
LM - Traffic Flowmap #5
MD Action Increment



- Legend:**
- 1 - Intersection (2019 Collected Data)
 - 7 - Intersection (Uncollected Data)
 - 100 - ATR Volume
 - 100 - Approach Volume

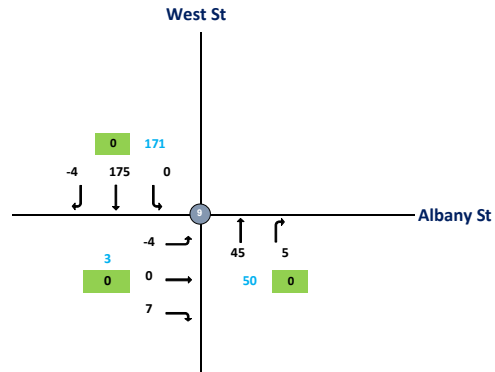

CBD Tolling
LM - Traffic Flowmap #6
MD Action Increment



- Legend:**
- 1 - Intersection (2019 Collected Data)
 - 7 - Intersection (Uncollected Data)
 - 100 - ATR Volume
 - 100 - Approach Volume
 - ↶ - Illegal movement

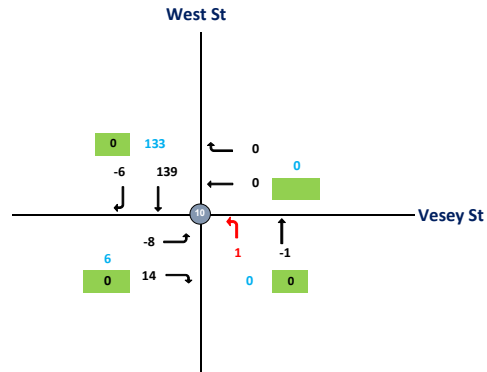

CBD Tolling
LM - Traffic Flowmap #7
MD Action Increment



- Legend:**
- 1 - Intersection (2019 Collected Data)
 - 7 - Intersection (Uncollected Data)
 - 100 - ATR Volume
 - 100 - Approach Volume

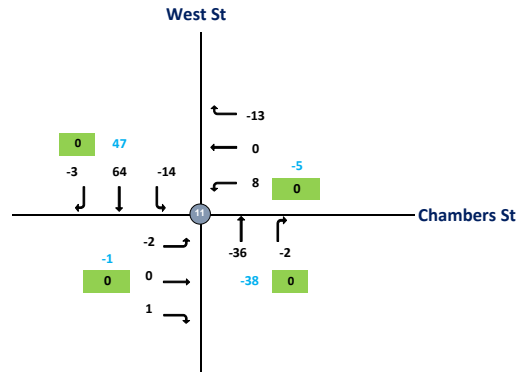

CBD Tolling
LM - Traffic Flowmap #8
MD Action Increment



- Legend:**
- Intersection (2019 Collected Data)
 - Intersection (Uncollected Data)
 - 100 - ATR Volume
 - 100 - Approach Volume

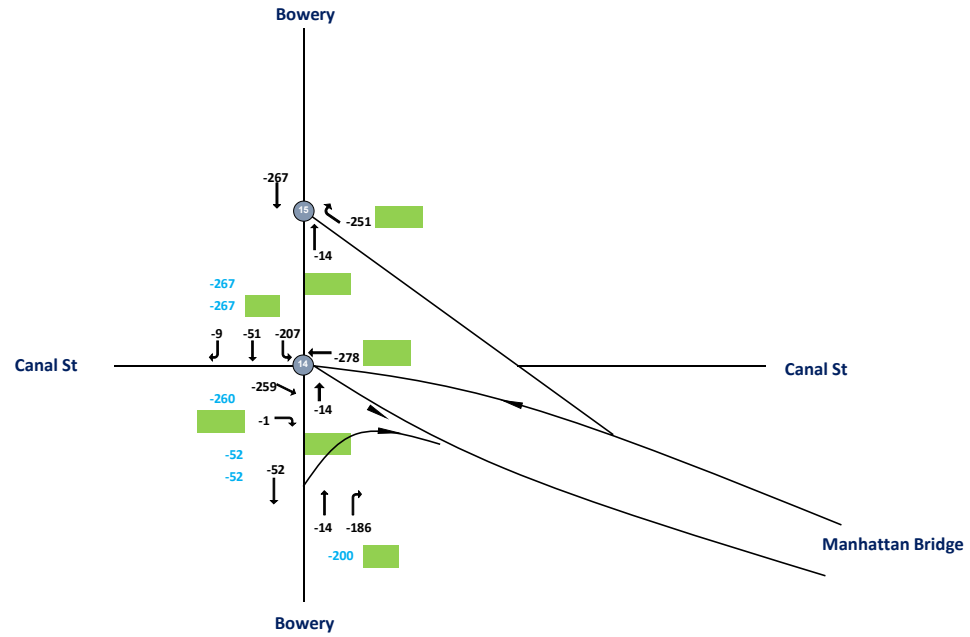

Intersection	Node	Approach	Balanced With-Action Increment					
			Inbound/Outbound					Total
			L2	L	T	R	R2	
Edgar St. and Trinity Pl. 2019 (TMC-010)	1							
Edgar St.	1	EB	0	0	0	0	0	
478 Exit Ramp.	1	NE	0	4	0	0	0	
Trinity Pl.	1	NB	0	-1	-9	0	0	
Trinity Pl.	1	SB	0	0	0	0	0	-6
Rector St. and Trinity Pl. 2019 (TMC-011)	2							
Rector St.	2	EB	0	-22	-1	0	0	
Rector St.	2	WB	0	0	0	0	0	
Trinity Pl.	2	NB	0	0	-5	0	0	
Trinity Pl.	2	SB	0	0	0	0	0	-28
West St. and HCT Exit. 2019 (TMC-012)	3							
-	3	EB	0	0	0	0	0	
HCT Exit.	3	WB	0	-4	0	0	0	
West St.	3	NB	0	0	-27	0	223	
West St.	3	SB	0	0	-106	0	0	86
West St. and HCT Exit. 2019 (TMC-012)	333							
W. Thams St.	333	EB	0	0	0	0	0	
HCT Exit.	333	WB	0	0	0	0	0	
West St.	333	NB	0	0	-27	0	0	
West St.	333	SB	0	0	-106	0	0	-133
Chambers St. and Centre St. 2018	4							
Chambers St.	4	EB	0	0	0	-76	0	
-	4	WB	0	0	0	0	0	
Centre St.	4	NB	0	-49	-59	0	0	
Centre St.	4	SB	0	0	-140	-4	0	-328
Hudson St. and Canal St. 2018	5							
Canal St.	5	EB	0	-16	-43	0	0	
Canal St.	5	WB	0	0	-10	-2	0	
Hudson St.	5	NB	0	0	0	-5	-5	
Hudson St.	5	SB	0	0	0	0	0	-81

Hudson St. and Canal St.								
2018	555							
Canal St.	555	EB	0	0	-48	0	0	
Canal St.	555	WB	0	0	-12	0	0	
Hudson St.	555	NB	0	0	0	0	0	
Hudson St.	555	SB	0	0	0	0	0	-60
West St. and Canal St N.								
2018	7							
Canal St N.	7	EB	0	0	0	0	0	
-	7	WB	0	0	0	0	0	
West St.	7	NB	0	0	-51	0	0	
West St.	7	SB	0	-83	-30	0	0	-164
West St. and Canal St S.								
2018	777							
-	777	EB	0	0	0	0	0	
Canal St S.	777	WB	0	0	0	0	0	
West St.	777	NB	0	0	-51	0	0	
West St.	777	SB	0	0	-113	0	0	-164
West St. and Albany St.								
2019 (TMC-013)	9							
Albany St.	9	EB	0	0	0	6	0	
-	9	WB	0	0	0	0	0	
West St.	9	NB	0	0	-57	-2	0	
West St.	9	SB	0	0	78	-4	0	21
West St. and Vesey St.								
2019 (TMC-014)	10							
Vesey St.	10	EB	0	-1	0	7	0	
Vesey St.	10	WB	0	0	0	0	0	
West St.	10	NB	0	0	-67	0	0	
West St.	10	SB	0	0	53	-5	0	-6
West St. and Chambers St.								
2019 (TMC-015)	11							
Chambers St.	11	EB	0	0	0	0	0	
Chambers St.	11	WB	0	8	0	-2	0	
West St.	11	NB	0	0	-98	-2	0	
West St.	11	SB	0	-13	-7	-5	0	-119

Bowey and Canal St./Manhattan Bridge Off-Ramp								
2018	14							
Canal St.	14	EB	0	0	-288	-2	0	
Manhattan Bridge Off-Ramp	14	WB	0	0	-214	0	0	
Bowey	14	NB	0	0	-6	-165	0	
Bowey	14	SB	0	-307	-73	-4	0	-1059
Bowey and Manhattan Bridge Off-Ramp								
2018	15							
	15	EB	0	0	0	0	0	
Manhattan Bridge Off-Ramp	15	WB	0	0	0	-213	0	
Bowey	15	NB	0	0	-6	0	0	
Bowey	15	SB	0	0	-384	0	0	-603
6th Ave. and Watts St								
2018	18							
Watts St	18	EB	0	0	0	0	0	
Watts St	18	WB	0	0	-31	0	0	
6th Ave.	18	NB	0	-26	-89	0	0	
6th Ave.	18	SB	0	0	0	0	0	-146
6th Ave. and Canal St.								
2018	19							
Canal St.	19	EB	0	0	-51	0	0	
Canal St.	19	WB	0	0	-104	-1	0	
6th Ave.	19	NB	0	-5	-73	-1	0	
Laight St.	19	NE	0	0	0	-66	0	-301

CBD Tolling
LM - Traffic Flowmap #1
PM Action Increment



- Legend:**
- 1 - Intersection (2019 Collected Data)
 - 7 - Intersection (Uncollected Data)
 - 100 - ATR Volume
 - 100 - Approach Volume

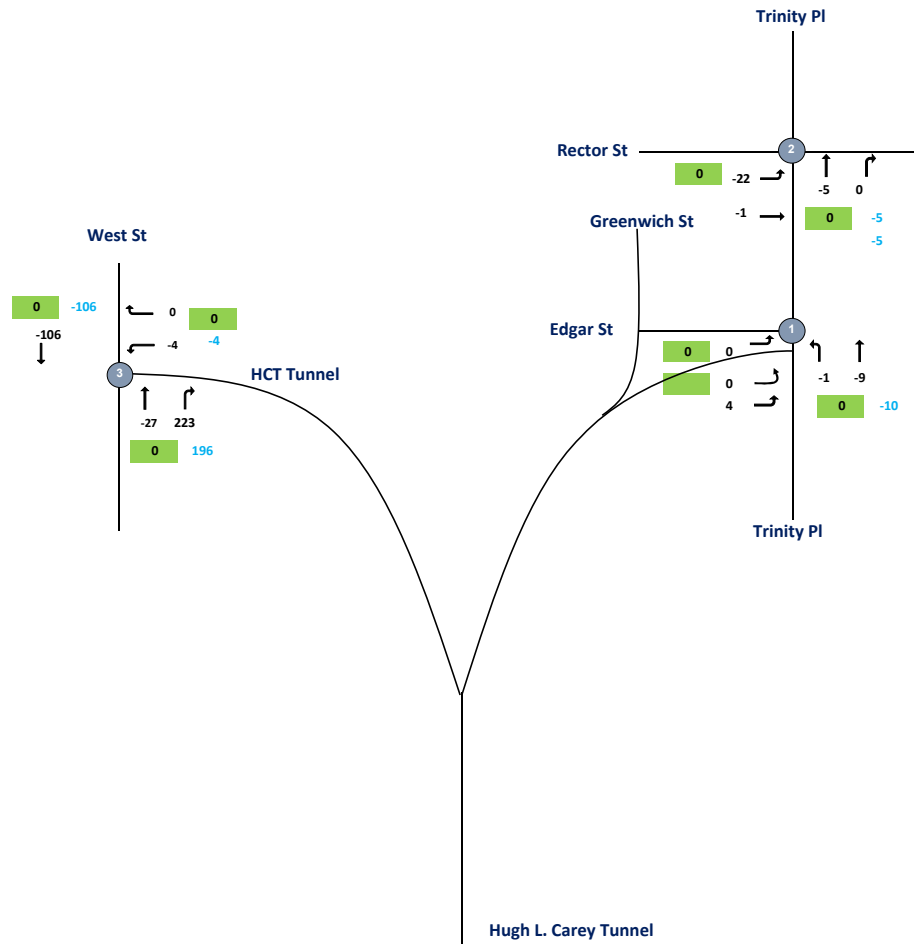

CBD Tolling
LM - Traffic Flowmap #2
PM Action Increment

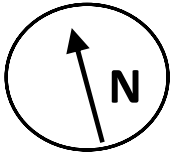

Legend:

1 - Intersection (2019 Collected Data)

7 - Intersection (Uncollected Data)

100 - ATR Volume

100 - Approach Volume

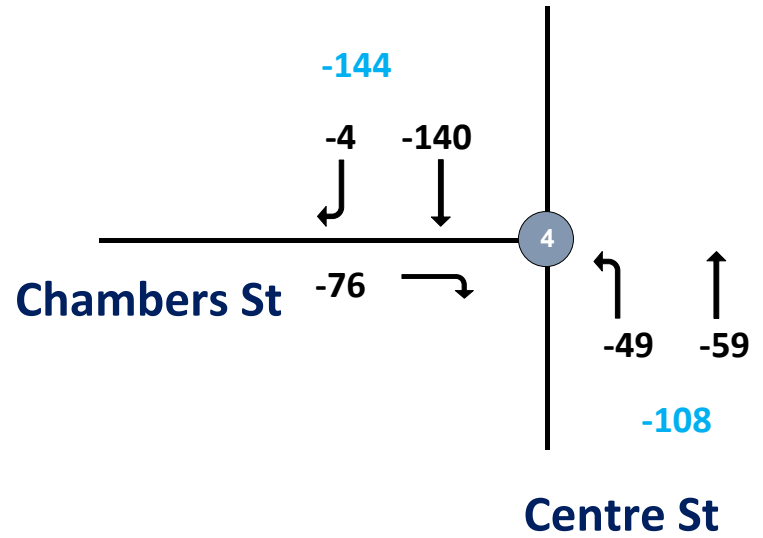

CBD Tolling
LM - Traffic Flowmap #3
PM Action Increment



- Legend:**
- Intersection (2019 Collected Data)
 - Intersection (Uncollected Data)
 - 100 - ATR Volume
 - 100 - Approach Volume

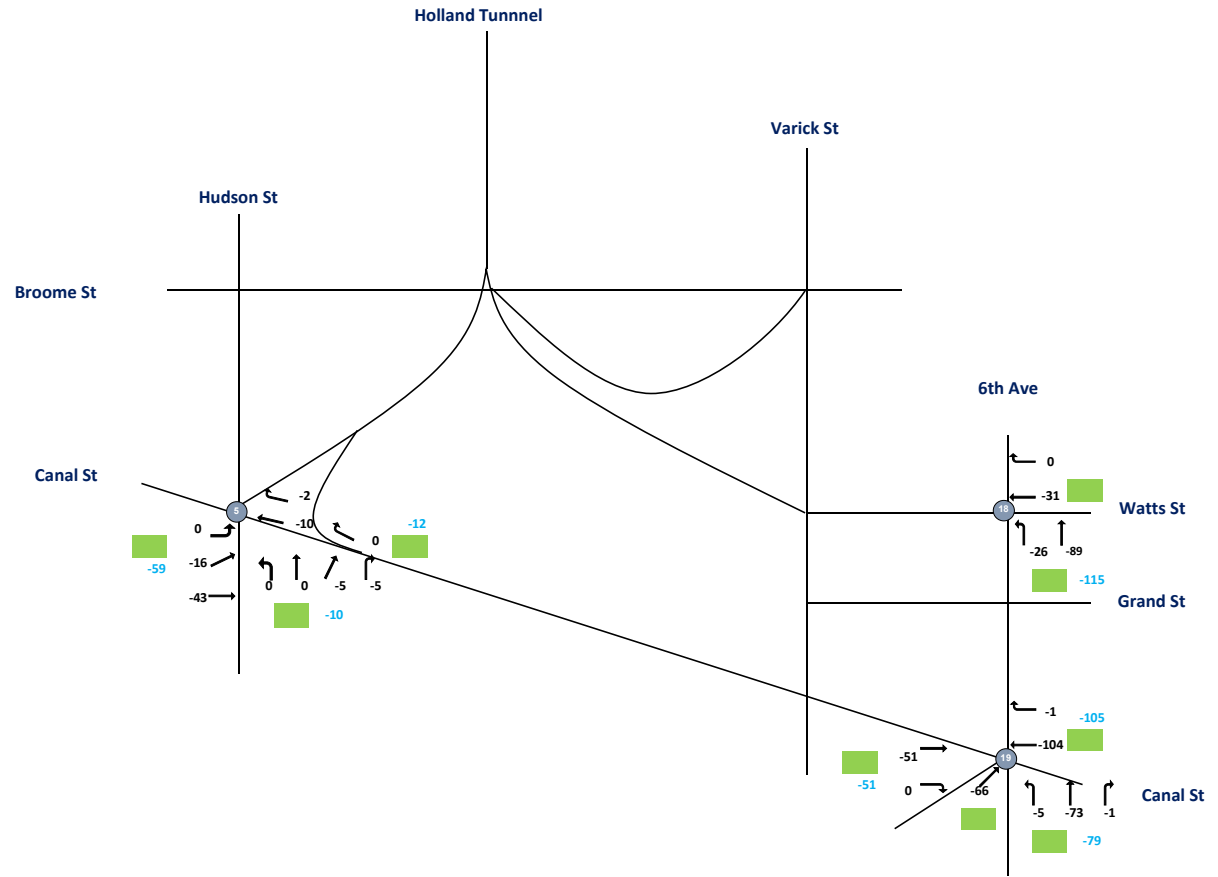

CBD Tolling
LM - Traffic Flowmap #4
PM Action Increment



- Legend:**
- Intersection (2019 Collected Data)
 - Intersection (Uncollected Data)
 - ATR Volume
 - Approach Volume

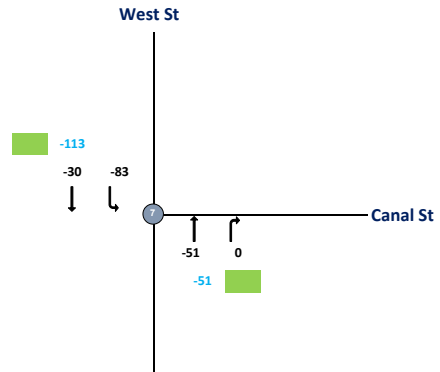

CBD Tolling
LM - Traffic Flowmap #5
PM Action Increment



- Legend:**
- Intersection (2019 Collected Data)
 - Intersection (Uncollected Data)
 - ATR Volume
 - Approach Volume

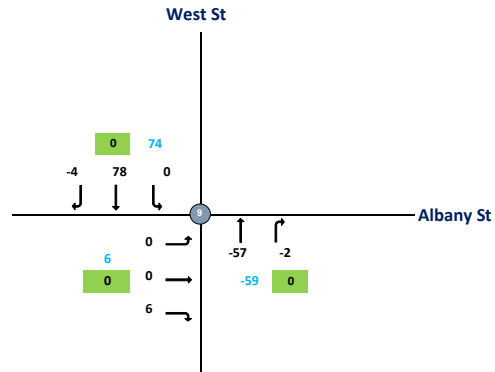

CBD Tolling
LM - Traffic Flowmap #6
PM Action Increment



- Legend:**
- 1 - Intersection (2019 Collected Data)
 - 7 - Intersection (Uncollected Data)
 - 100 - ATR Volume
 - 100 - Approach Volume
 - ↯ - Illegal movement

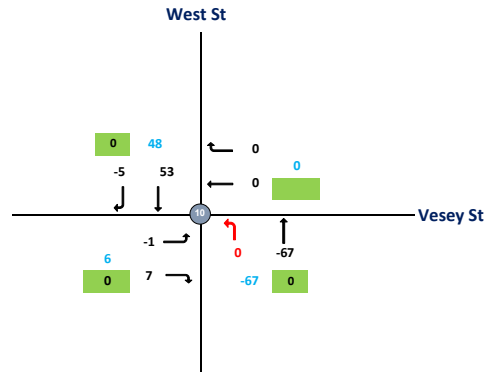

CBD Tolling
LM - Traffic Flowmap #7
PM Action Increment



- Legend:**
- 1 - Intersection (2019 Collected Data)
 - 7 - Intersection (Uncollected Data)
 - 100 - ATR Volume
 - 100 - Approach Volume

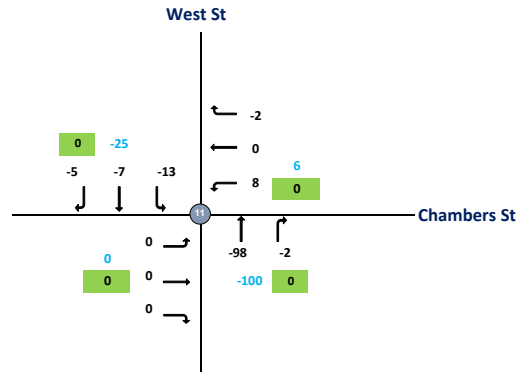

CBD Tolling
LM - Traffic Flowmap #8
PM Action Increment



- Legend:**
- Intersection (2019 Collected Data)
 - Intersection (Uncollected Data)
 - ATR Volume
 - Approach Volume

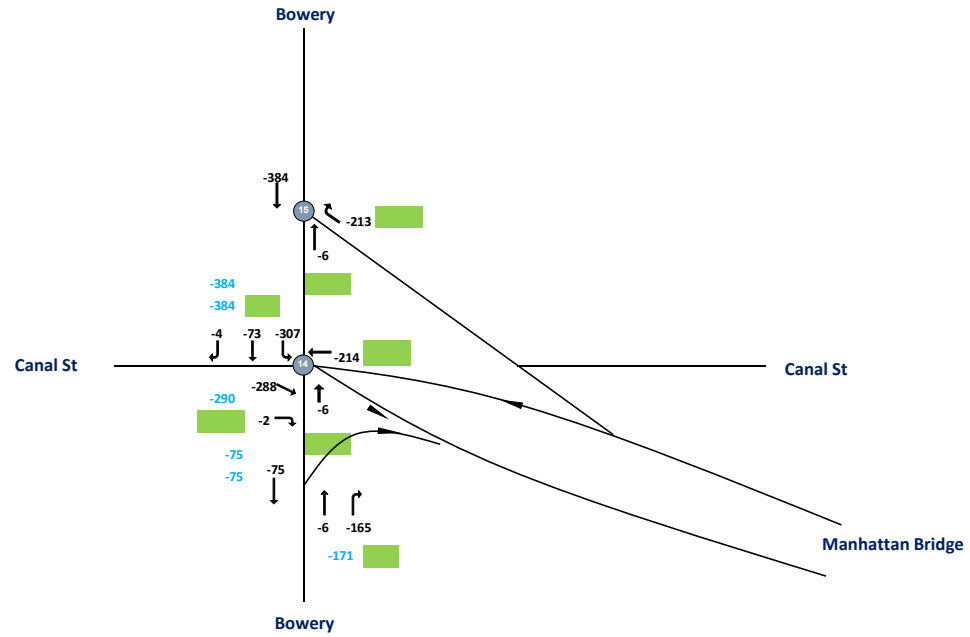

Intersection	Node	Approach	Balanced With-Action Increment					
			Inbound/Outbound					Total
			PM Peak Hour					
L2	L	T	R	R2				
Edgar St. and Trinity Pl. 2019 (TMC-010)	1							
Edgar St.	1	EB	0	0	0	0	0	
478 Exit Ramp.	1	NE	0	4	0	0	0	
Trinity Pl.	1	NB	0	-1	-9	0	0	
Trinity Pl.	1	SB	0	0	0	0	0	-6
Rector St. and Trinity Pl. 2019 (TMC-011)	2							
Rector St.	2	EB	0	-22	-1	0	0	
Rector St.	2	WB	0	0	0	0	0	
Trinity Pl.	2	NB	0	0	-5	0	0	
Trinity Pl.	2	SB	0	0	0	0	0	-28
West St. and HCT Exit. 2019 (TMC-012)	3							
-	3	EB	0	0	0	0	0	
HCT Exit.	3	WB	0	-4	0	0	0	
West St.	3	NB	0	0	-27	0	223	
West St.	3	SB	0	0	-106	0	0	86
West St. and HCT Exit. 2019 (TMC-012)	333							
W. Thams St.	333	EB	0	0	0	0	0	
HCT Exit.	333	WB	0	0	0	0	0	
West St.	333	NB	0	0	-27	0	0	
West St.	333	SB	0	0	-106	0	0	-133
Chambers St. and Centre St. 2018	4							
Chambers St.	4	EB	0	0	0	-76	0	
-	4	WB	0	0	0	0	0	
Centre St.	4	NB	0	-49	-59	0	0	
Centre St.	4	SB	0	0	-140	-4	0	-328
Hudson St. and Canal St. 2018	5							
Canal St.	5	EB	0	-16	-43	0	0	
Canal St.	5	WB	0	0	-10	-2	0	
Hudson St.	5	NB	0	0	0	-5	-5	
Hudson St.	5	SB	0	0	0	0	0	-81

Hudson St. and Canal St.								
2018	555							
Canal St.	555	EB	0	0	-48	0	0	
Canal St.	555	WB	0	0	-12	0	0	
Hudson St.	555	NB	0	0	0	0	0	
Hudson St.	555	SB	0	0	0	0	0	-60
West St. and Canal St N.								
2018	7							
Canal St N.	7	EB	0	0	0	0	0	
-	7	WB	0	0	0	0	0	
West St.	7	NB	0	0	-51	0	0	
West St.	7	SB	0	-83	-30	0	0	-164
West St. and Canal St S.								
2018	777							
-	777	EB	0	0	0	0	0	
Canal St S.	777	WB	0	0	0	0	0	
West St.	777	NB	0	0	-51	0	0	
West St.	777	SB	0	0	-113	0	0	-164
West St. and Albany St.								
2019 (TMC-013)	9							
Albany St.	9	EB	0	0	0	6	0	
-	9	WB	0	0	0	0	0	
West St.	9	NB	0	0	-57	-2	0	
West St.	9	SB	0	0	78	-4	0	21
West St. and Vesey St.								
2019 (TMC-014)	10							
Vesey St.	10	EB	0	-1	0	7	0	
Vesey St.	10	WB	0	0	0	0	0	
West St.	10	NB	0	0	-67	0	0	
West St.	10	SB	0	0	53	-5	0	-6
West St. and Chambers St.								
2019 (TMC-015)	11							
Chambers St.	11	EB	0	0	0	0	0	
Chambers St.	11	WB	0	8	0	-2	0	
West St.	11	NB	0	0	-98	-2	0	
West St.	11	SB	0	-13	-7	-5	0	-119

Bowey and Canal St./Manhattan Bridge Off-Ramp								
2018	14							
Canal St.	14	EB	0	0	-288	-2	0	
Manhattan Bridge Off-Ramp	14	WB	0	0	-214	0	0	
Bowey	14	NB	0	0	-6	-165	0	
Bowey	14	SB	0	-307	-73	-4	0	-1059
Bowey and Manhattan Bridge Off-Ramp								
2018	15							
	15	EB	0	0	0	0	0	
Manhattan Bridge Off-Ramp	15	WB	0	0	0	-213	0	
Bowey	15	NB	0	0	-6	0	0	
Bowey	15	SB	0	0	-384	0	0	-603
6th Ave. and Watts St								
2018	18							
Watts St	18	EB	0	0	0	0	0	
Watts St	18	WB	0	0	-31	0	0	
6th Ave.	18	NB	0	-26	-89	0	0	
6th Ave.	18	SB	0	0	0	0	0	-146
6th Ave. and Canal St.								
2018	19							
Canal St.	19	EB	0	0	-51	0	0	
Canal St.	19	WB	0	0	-104	-1	0	
6th Ave.	19	NB	0	-5	-73	-1	0	
Laight St.	19	NE	0	0	0	-66	0	-301

CBD Tolling
LT #2 - Traffic Flowmap
AM Action Increment



- Legend:**
- 1 - Intersection (2019 Collected Data)
 - 7 - Intersection (Pre-2019 Collected Data)
 - 100 - ATR Volume
 - 100 - Approach Volume

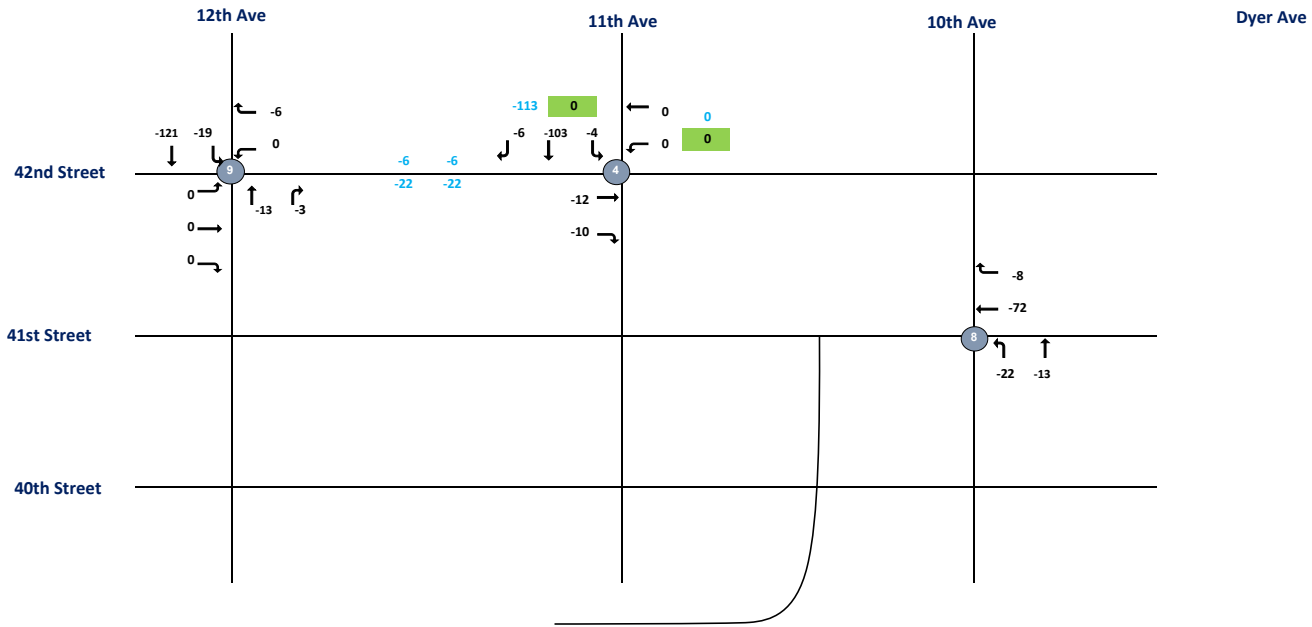

LT

8:00:00 AM

Intersection	Node	Approach	Total Vehicles						Total
			Inbound/Outbound						
			AM Peak Hour						
			L2	L	T	R	R2		
33rd Street and 9th Avenue 2019 (WRY-TMC-109)	1								
33rd Street	1	EB	0	0	0	0	0		
33rd Street	1	WB	0	0	-3	0	0		
9th Avenue	1	NB	0	0	0	0	0		
9th Avenue	1	SB	0	0	-41	-4	0	-48	
34th Street and Dyer Avenue 2019 (WRY-TMC-105)	2								
34th Street	2	EB	0	0	-16	0	0		
34th Street	2	WB	0	0	-5	-1	0		
Dyer Avenue	2	NB	0	0	0	0	0		
Dyer Avenue	2	SB	0	-5	0	-2	0	-29	
34th Street and 12th Avenue 2019 (PABT-TMC-055)	3								
34th Street	3	EB	0	0	0	0	0		
34th Street	3	WB	0	-5	0	0	0		
12th Avenue	3	NB	0	0	-21	-3	0		
12th Avenue	3	SB	0	-9	-111	0	0	-149	
42nd Street and 11th Avenue 2019 (PABT-TMC-052)	4								
42nd Street	4	EB	0	0	-12	-10	0		
42nd Street	4	WB	0	0	0	0	0		
11th Avenue	4	NB	0	0	0	0	0		
11th Avenue	4	SB	0	-4	-103	-6	0	-135	
36th Street and Dyer Avenue 2019 (PABT-TMC-060)	5								
36th Street	5	EB	0	0	-9	-1	0		
36th Street	5	WB	0	0	0	0	0		
Dyer Avenue	5	NB	0	0	-8	-1	0		
Dyer Avenue	5	SB	0	-7	-10	-3	0	-39	
33rd Street and 10th Avenue 2019 (WRY-TMC-108)	6								
33rd Street	6	EB	0	0	0	0	0		
33rd Street	6	WB	0	0	0	-7	0		
10th Avenue	6	NB	0	0	-22	0	0		
10th Avenue	6	SB	0	0	0	0	0	-29	

34th Street and 11th Avenue 2019 (PABT-TMC-044)	7								
34th Street	7	EB	0	-3	-8	-1	0		
34th Street	7	WB	0	-1	-1	-1	0		
11th Avenue	7	NB	0	0	0	0	0		
11th Avenue	7	SB	0	-4	-29	-4	0		-52
34th Street and 11th Avenue 2019 (PABT-TMC-040)	8								
34th Street	8	EB	0	0	0	0	0		
34th Street	8	WB	0	0	-72	-8	0		
11th Avenue	8	NB	0	-22	-13	0	0		
11th Avenue	8	SB	0	0	0	0	0		-115
42nd Street and 12th Avenue 2019 (PABT-TMC-057)	9								
42nd Street	9	EB	0	0	0	0	0		
42nd Street	9	WB	0	0	0	-6	0		
12th Avenue	9	NB	0	0	-13	-3	0		
12th Avenue	9	SB	0	-19	-121	0	0		-162

CBD Tolling
LT #1 - Traffic Flowmap
MD Action Increment



- Legend:**
- 1 - Intersection (2019 Collected Data)
 - 7 - Intersection (Pre-2019 Collected Data)
 - 100 - ATR Volume
 - 100 - Approach Volume

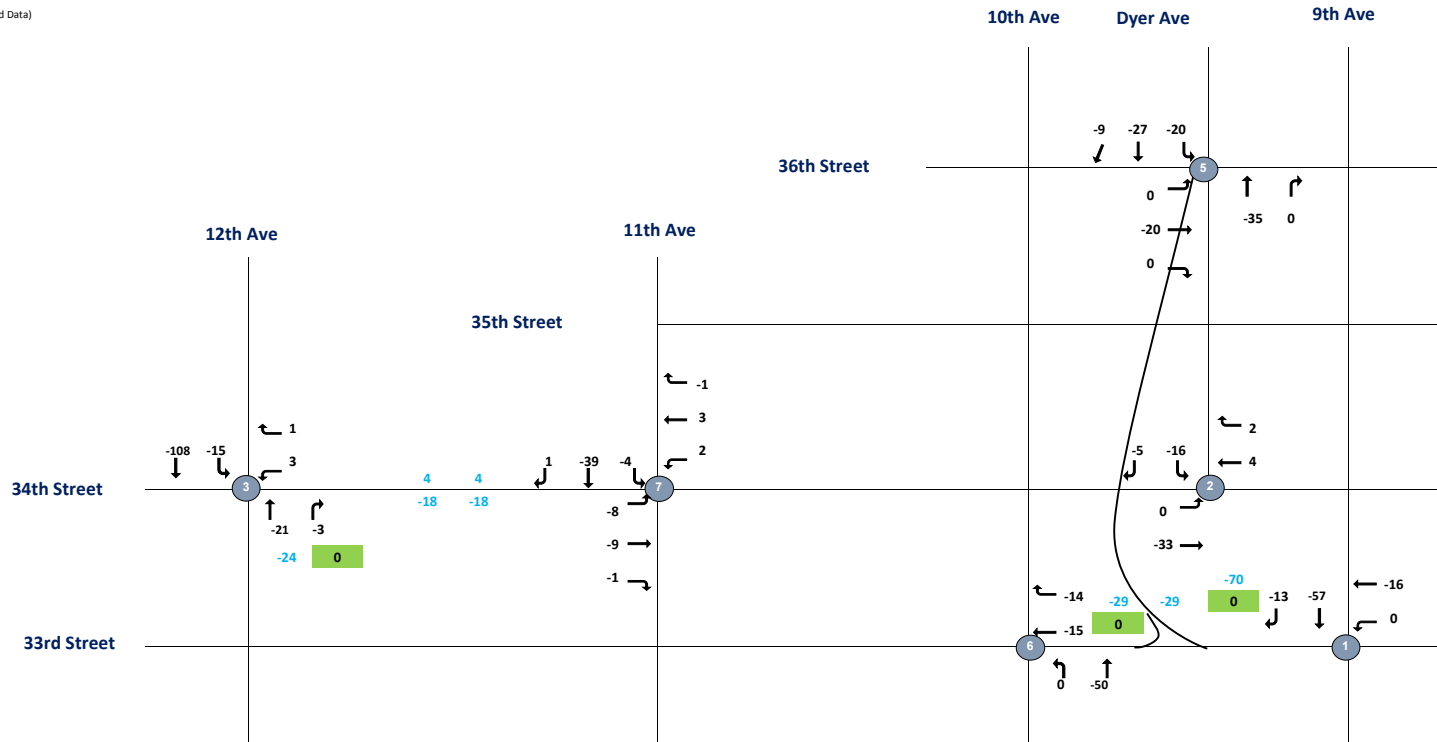

CBD Tolling
LT #2 - Traffic Flowmap
MD Action Increment



- Legend:**
- 1 - Intersection (2019 Collected Data)
 - 7 - Intersection (Pre-2019 Collected Data)
 - 100 - ATR Volume
 - 100 - Approach Volume

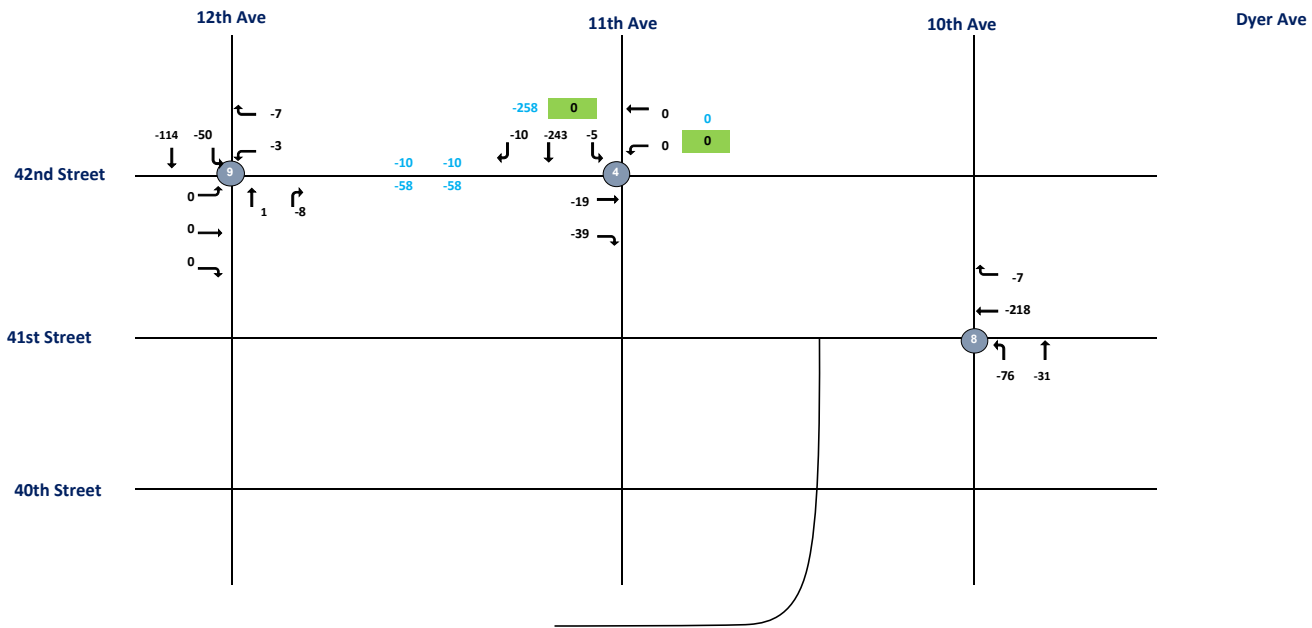

LT

12:00:00 PM

Intersection	Node	Approach	Total Vehicles					
			Inbound/Outbound					
			MD Peak Hour					
			L2	L	T	R	R2	Total
33rd Street and 9th Avenue 2019 (WRY-TMC-109)	1							
33rd Street	1	EB	0	0	0	0	0	
33rd Street	1	WB	0	0	-16	0	0	
9th Avenue	1	NB	0	0	0	0	0	
9th Avenue	1	SB	0	0	-57	-13	0	-86
34th Street and Dyer Avenue 2019 (WRY-TMC-105)	2							
34th Street	2	EB	0	0	-33	0	0	
34th Street	2	WB	0	0	4	2	0	
Dyer Avenue	2	NB	0	0	0	0	0	
Dyer Avenue	2	SB	0	-16	0	-5	0	-48
34th Street and 12th Avenue 2019 (PABT-TMC-055)	3							
34th Street	3	EB	0	0	0	0	0	
34th Street	3	WB	0	3	0	1	0	
12th Avenue	3	NB	0	0	-21	-3	0	
12th Avenue	3	SB	0	-15	-108	0	0	-143
42nd Street and 11th Avenue 2019 (PABT-TMC-052)	4							
42nd Street	4	EB	0	0	-19	-39	0	
42nd Street	4	WB	0	0	0	0	0	
11th Avenue	4	NB	0	0	0	0	0	
11th Avenue	4	SB	0	-5	-243	-10	0	-316
36th Street and Dyer Avenue 2019 (PABT-TMC-060)	5							
36th Street	5	EB	0	0	-20	0	0	
36th Street	5	WB	0	0	0	0	0	
Dyer Avenue	5	NB	0	0	-35	0	0	
Dyer Avenue	5	SB	0	-20	-27	-9	0	-111
33rd Street and 10th Avenue 2019 (WRY-TMC-108)	6							
33rd Street	6	EB	0	0	0	0	0	
33rd Street	6	WB	0	0	-15	-14	0	
10th Avenue	6	NB	0	0	-50	0	0	
10th Avenue	6	SB	0	0	0	0	0	-79

34th Street and 11th Avenue 2019 (PABT-TMC-044)	7								
34th Street	7	EB	0	-8	-9	-1	0		
34th Street	7	WB	0	2	3	-1	0		
11th Avenue	7	NB	0	0	0	0	0		
11th Avenue	7	SB	0	-4	-39	1	0		-56
34th Street and 11th Avenue 2019 (PABT-TMC-040)	8								
34th Street	8	EB	0	0	0	0	0		
34th Street	8	WB	0	0	-218	-7	0		
11th Avenue	8	NB	0	-76	-31	0	0		
11th Avenue	8	SB	0	0	0	0	0		-332
42nd Street and 12th Avenue 2019 (PABT-TMC-057)	9								
42nd Street	9	EB	0	0	0	0	0		
42nd Street	9	WB	0	-3	0	-7	0		
12th Avenue	9	NB	0	0	1	-8	0		
12th Avenue	9	SB	0	-50	-114	0	0		-181

CBD Tolling
LT #1 - Traffic Flowmap
PM Action Increment



- Legend:**
- 1 - Intersection (2019 Collected Data)
 - 7 - Intersection (Pre-2019 Collected Data)
 - 100 - ATR Volume
 - 100 - Approach Volume

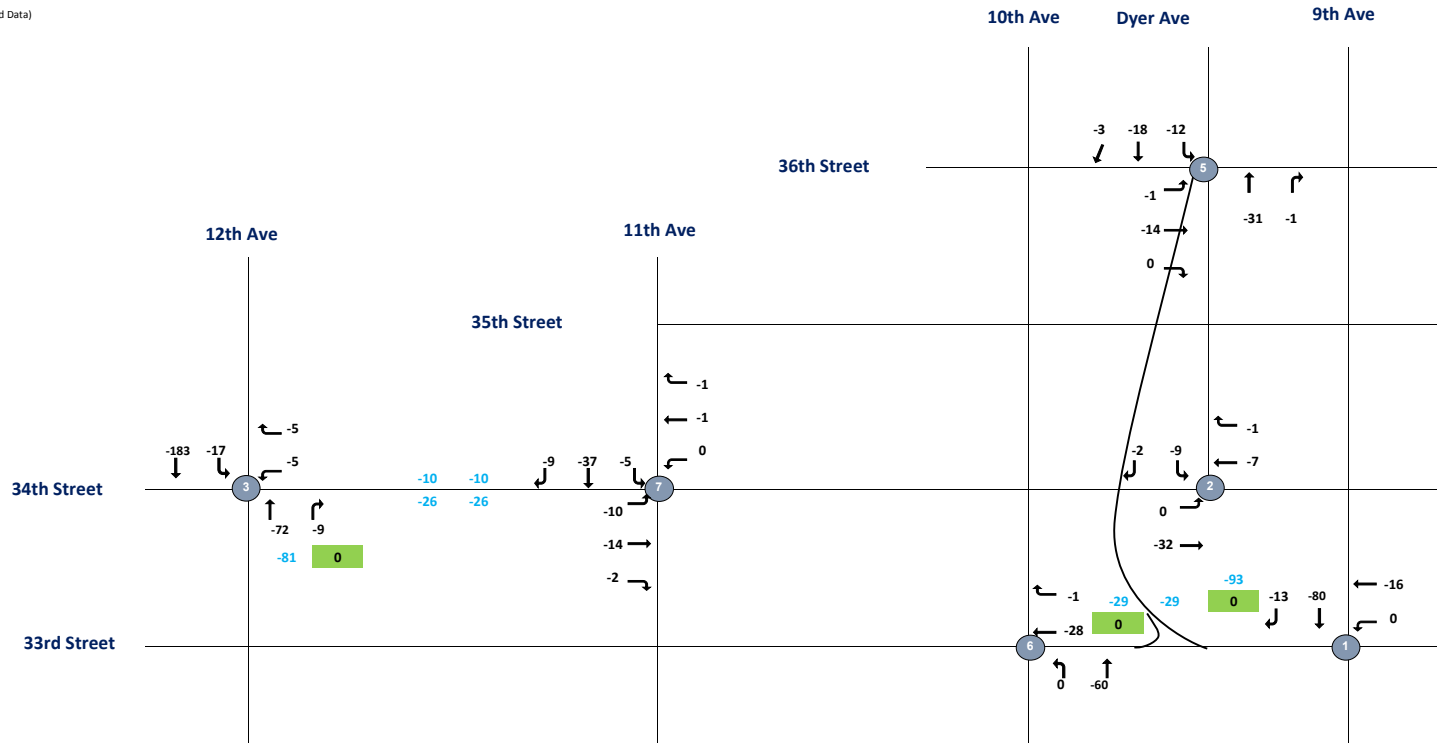

CBD Tolling
LT #2 - Traffic Flowmap
PM Action Increment



- Legend:**
- Intersection (2019 Collected Data)
 - Intersection (Pre-2019 Collected Data)
 - 100 - ATR Volume
 - 100 - Approach Volume

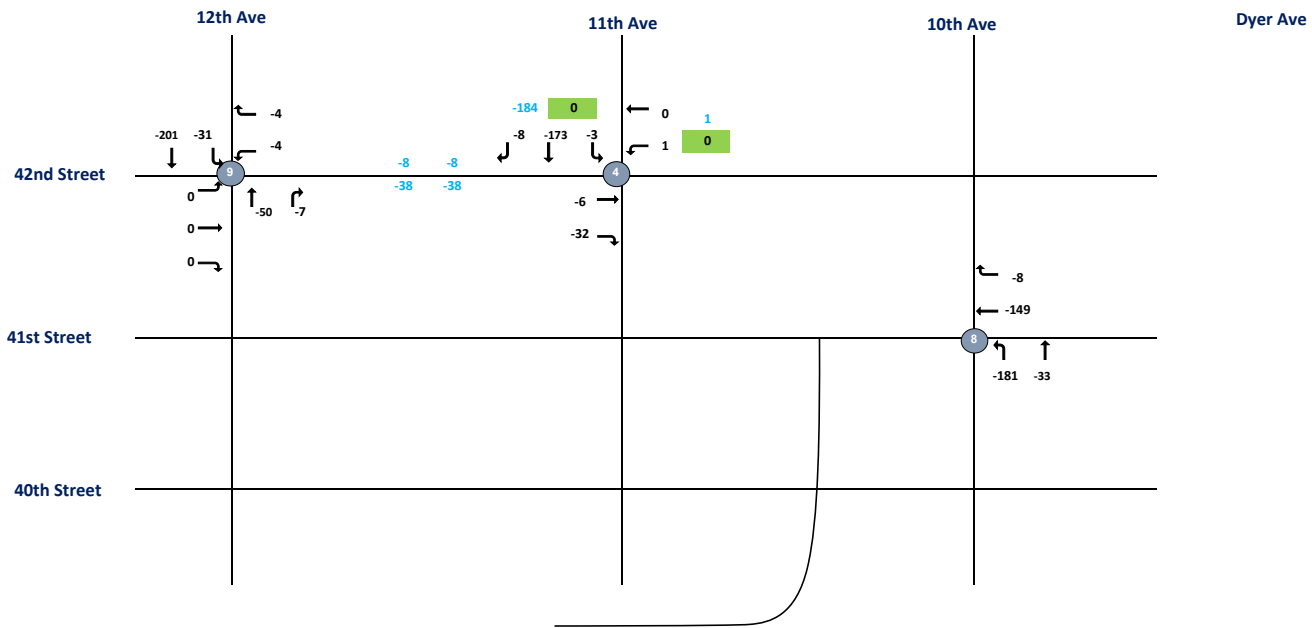

LT

5:00:00 PM

Intersection	Node	Approach	Total Vehicles					
			Inbound/Outbound					
			PM Peak Hour					
			L2	L	T	R	R2	Total
33rd Street and 9th Avenue 2019 (WRY-TMC-109)	1							
33rd Street	1	EB	0	0	0	0	0	
33rd Street	1	WB	0	0	-16	0	0	
9th Avenue	1	NB	0	0	0	0	0	
9th Avenue	1	SB	0	0	-80	-13	0	-109
34th Street and Dyer Avenue 2019 (WRY-TMC-105)	2							
34th Street	2	EB	0	0	-32	0	0	
34th Street	2	WB	0	0	-7	-1	0	
Dyer Avenue	2	NB	0	0	0	0	0	
Dyer Avenue	2	SB	0	-9	0	-2	0	-51
34th Street and 12th Avenue 2019 (PABT-TMC-055)	3							
34th Street	3	EB	0	0	0	0	0	
34th Street	3	WB	0	-5	0	-5	0	
12th Avenue	3	NB	0	0	-72	-9	0	
12th Avenue	3	SB	0	-17	-183	0	0	-291
42nd Street and 11th Avenue 2019 (PABT-TMC-052)	4							
42nd Street	4	EB	0	0	-6	-32	0	
42nd Street	4	WB	0	1	0	0	0	
11th Avenue	4	NB	0	0	0	0	0	
11th Avenue	4	SB	0	-3	-173	-8	0	-221
36th Street and Dyer Avenue 2019 (PABT-TMC-060)	5							
36th Street	5	EB	0	-1	-14	0	0	
36th Street	5	WB	0	0	0	0	0	
Dyer Avenue	5	NB	0	0	-31	-1	0	
Dyer Avenue	5	SB	0	-12	-18	-3	0	-80
33rd Street and 10th Avenue 2019 (WRY-TMC-108)	6							
33rd Street	6	EB	0	0	0	0	0	
33rd Street	6	WB	0	0	-28	-1	0	
10th Avenue	6	NB	0	0	-60	0	0	
10th Avenue	6	SB	0	0	0	0	0	-89

34th Street and 11th Avenue 2019 (PABT-TMC-044)	7								
34th Street	7	EB	0	-10	-14	-2	0		
34th Street	7	WB	0	0	-1	-1	0		
11th Avenue	7	NB	0	0	0	0	0		
11th Avenue	7	SB	0	-5	-37	-9	0		-79
34th Street and 11th Avenue 2019 (PABT-TMC-040)	8								
34th Street	8	EB	0	0	0	0	0		
34th Street	8	WB	0	0	-149	-8	0		
11th Avenue	8	NB	0	-181	-33	0	0		
11th Avenue	8	SB	0	0	0	0	0		-371
42nd Street and 12th Avenue 2019 (PABT-TMC-057)	9								
42nd Street	9	EB	0	0	0	0	0		
42nd Street	9	WB	0	-4	0	-4	0		
12th Avenue	9	NB	0	0	-50	-7	0		
12th Avenue	9	SB	0	-31	-201	0	0		-297

**New Jersey
2021 With-Action N1 Increment
AM Peak Hour**

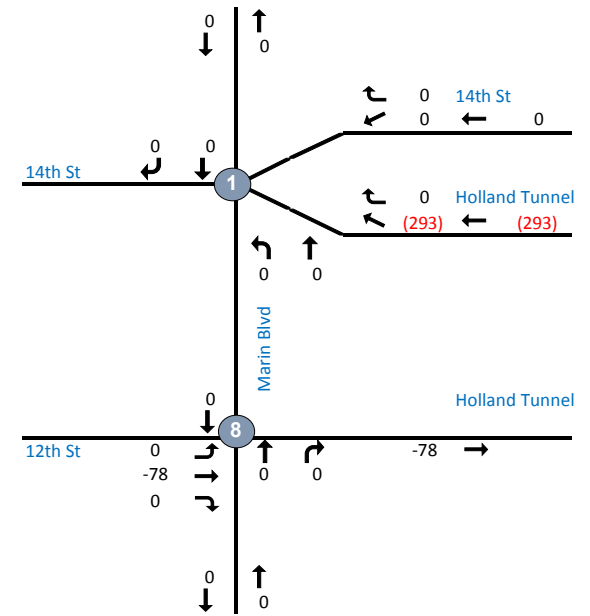
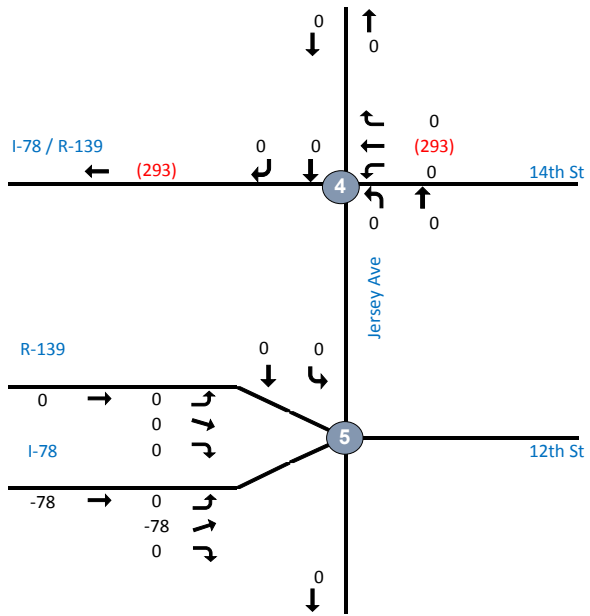

Intersection	Node	Approach	Total Vehicles						Total
			Inbound/Outbound						
			AM Peak Hour						
			L2	L	T	R	R2		
14th Street (E-W) & Jersey Avenue (N-S)									
NJ-TMC-007.xlsx									
n/a	4	EB	0	0	0	0	0		
14th Street	4	WB	0	0	-293	0	0		
Jersey Avenue	4	NB	0	0	0	0	0		
Jersey Avenue	4	SB	0	0	0	0	0	-293	
14th Street/Holland Tunnel (E-W) & Marin Boulevard (N-S)									
NJ-TMC-008.xlsx									
Holland Tunnel	1	WB	0	0	-293	0	0		
14th Street	1	SW	0	0	0	0	0		
Marin Boulevard	1	NB	0	0	0	0	0		
Marin Boulevard	1	SB	0	0	0	0	0	-293	
12th Street (E-W) & Jersey Avenue (N-S)									
NJ-TMC-009.xlsx	5								
R-139	5	SE	0	0	0	0	0		
I-78	5	EB	0	0	-78	0	0		
Jersey Avenue	5	NB	0	0	0	0	0		
Jersey Avenue	5	SB	0	0	0	0	0	-78	
12th Street (E-W) & Marin Blvd (N-S)									
NJ-TMC-010.xlsx	8								
12th Street/Holland Tunnel	8	EB	0	0	-78	0	0		
n/a	8	WB	0	0	0	0	0		
Marin Boulevard	8	NB	0	0	0	0	0		
Marin Boulevard	8	SB	0	0	0	0	0	-78	

**New Jersey
2021 With-Action N1 Increment
MD Peak Hour**

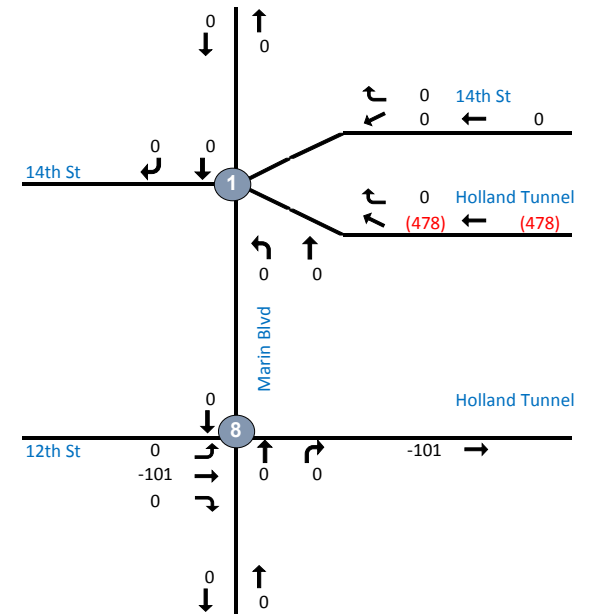
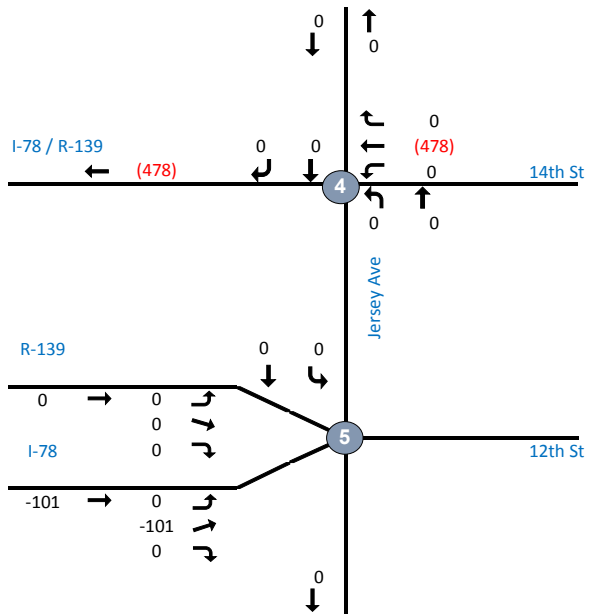

Intersection	Node	Approach	Total Vehicles					Total
			Inbound/Outbound					
			L2	L	T	R	R2	
14th Street (E-W) & Jersey Avenue (N-S)								
NJ-TMC-007.xlsx								
n/a	4	EB	0	0	0	0	0	
14th Street	4	WB	0	0	-478	0	0	
Jersey Avenue	4	NB	0	0	0	0	0	
Jersey Avenue	4	SB	0	0	0	0	0	
							-478	
14th Street/Holland Tunnel (E-W) & Marin Boulevard (N-S)								
NJ-TMC-008.xlsx								
Holland Tunnel	1	WB	0	0	-478	0	0	
14th Street	1	SW	0	0	0	0	0	
Marin Boulevard	1	NB	0	0	0	0	0	
Marin Boulevard	1	SB	0	0	0	0	0	
							-478	
12th Street (E-W) & Jersey Avenue (N-S)								
NJ-TMC-009.xlsx	5							
R-139	5	SE	0	0	0	0	0	
I-78	5	EB	0	0	-101	0	0	
Jersey Avenue	5	NB	0	0	0	0	0	
Jersey Avenue	5	SB	0	0	0	0	0	
							-101	
12th Street (E-W) & Marin Blvd (N-S)								
NJ-TMC-010.xlsx	8							
12th Street/Holland Tunnel	8	EB	0	0	-101	0	0	
n/a	8	WB	0	0	0	0	0	
Marin Boulevard	8	NB	0	0	0	0	0	
Marin Boulevard	8	SB	0	0	0	0	0	
							-101	

**New Jersey
2021 With-Action N1 Increment
PM Peak Hour**

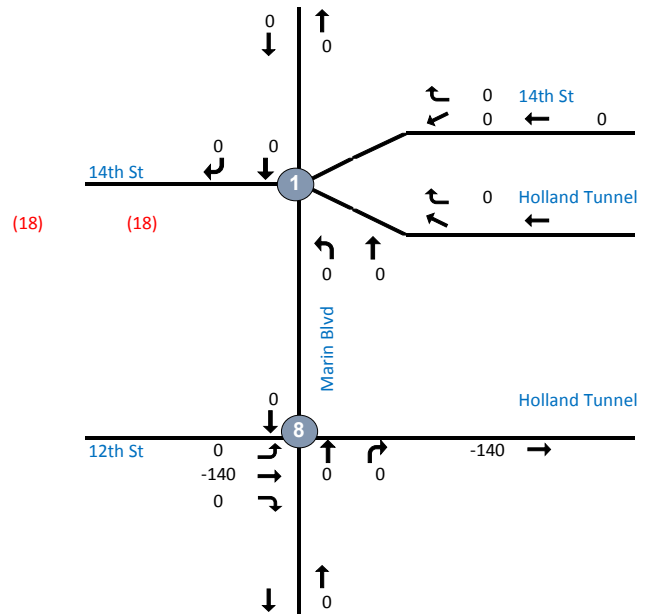
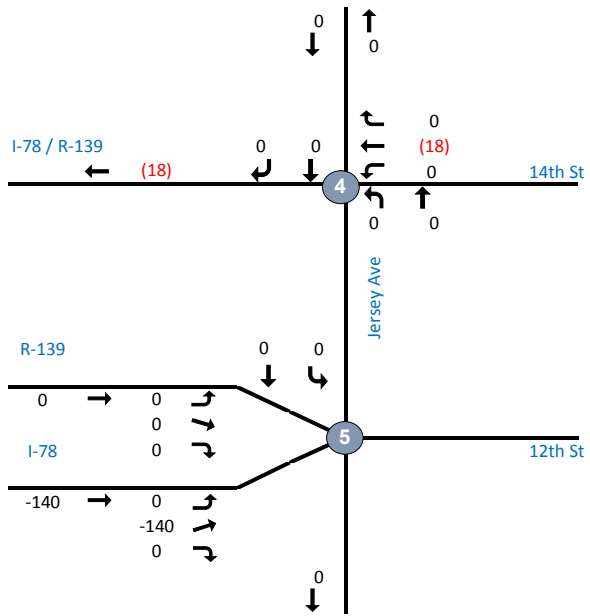

0

Intersection	Node	Approach	Total Vehicles						
			Inbound/Outbound						
			L2	L	T	R	R2	Total	
14th Street (E-W) & Jersey Avenue (N-S)									
NJ-TMC-007.xlsx									
n/a	4	EB	0	0	0	0	0		
14th Street	4	WB	0	0	-18	0	0		
Jersey Avenue	4	NB	0	0	0	0	0		
Jersey Avenue	4	SB	0	0	0	0	0		-18
14th Street/Holland Tunnel (E-W) & Marin Boulevard (N-S)									
NJ-TMC-008.xlsx									
Holland Tunnel	1	WB	0	0	-18	0	0		
14th Street	1	SW	0	0	0	0	0		
Marin Boulevard	1	NB	0	0	0	0	0		
Marin Boulevard	1	SB	0	0	0	0	0		-18
12th Street (E-W) & Jersey Avenue (N-S)									
NJ-TMC-009.xlsx	5								
R-139	5	SE	0	0	0	0	0		
I-78	5	EB	0	0	-140	0	0		
Jersey Avenue	5	NB	0	0	0	0	0		
Jersey Avenue	5	SB	0	0	0	0	0		-140
12th Street (E-W) & Marin Blvd (N-S)									
NJ-TMC-010.xlsx	8								
12th Street/Holland Tunnel	8	EB	0	0	-140	0	0		
n/a	8	WB	0	0	0	0	0		
Marin Boulevard	8	NB	0	0	0	0	0		
Marin Boulevard	8	SB	0	0	0	0	0		-140

CBD Tolling
QMT - Traffic Flowmap
AM Action Increment



- Legend:**
- 1 - Intersection (2019 Collected Data)
 - 7 - Intersection (Uncollected Data)
 - 100 - ATR Volume
 - 100 - Approach Volume

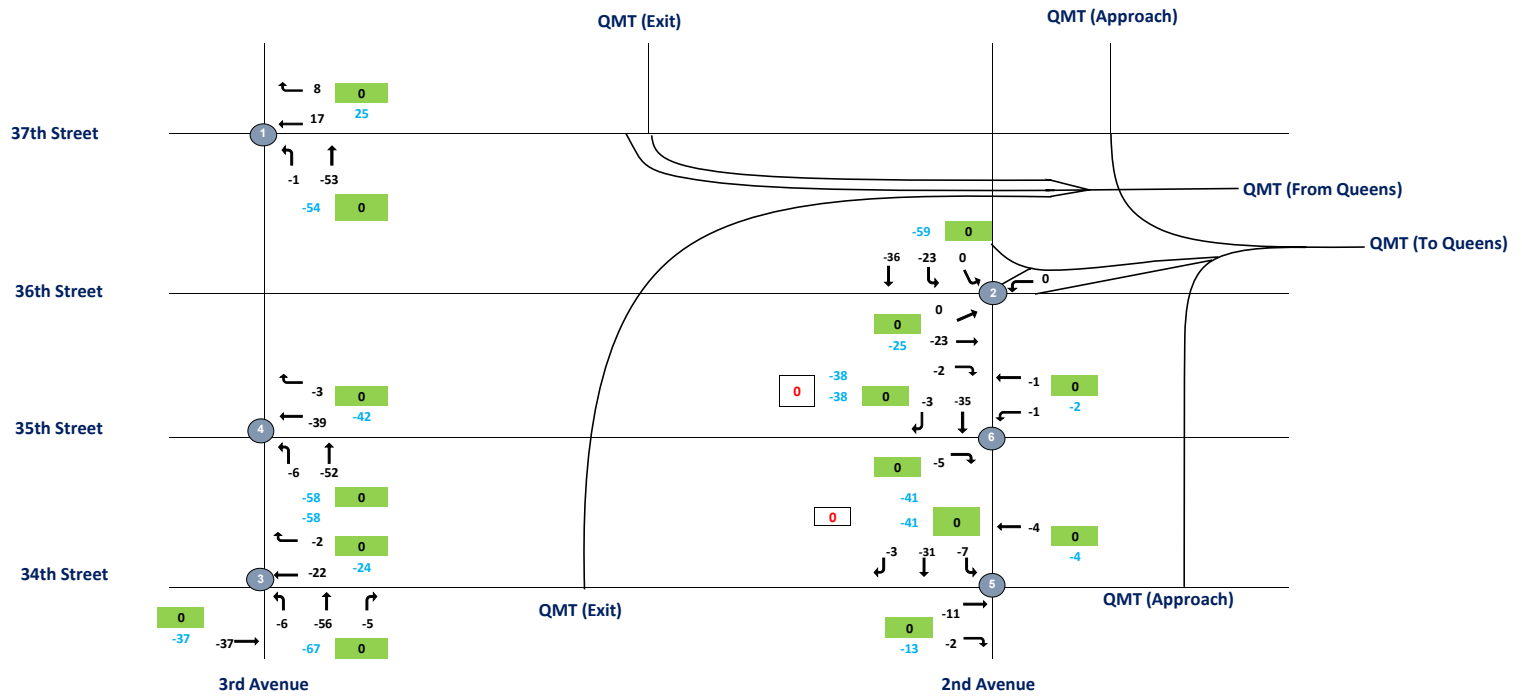

QM

8:00:00 AM

Intersection	Node	Approach	Balanced With-Action Increment						
			Inbound/Outbound						
			AM Peak Hour						
			L2	L	T	R	R2	Total	
37th St & 3rd Ave 2019 (TMC-016)	1								
37th St	1	EB	0	0	0	0	0		
37th St	1	WB	0	0	17	8	0		
3rd Ave	1	NB	0	-1	-53	0	0		
3rd Ave	1	SB	0	0	0	0	0		-29
36th St & 2nd Ave 2019 (TMC-017)	2								
36th St	2	EB	0	0	-23	-2	0		
36th St	2	WB	0	0	0	0	0		
2nd Ave	2	NB	0	0	0	0	0		
2nd Ave	2	SB	0	-23	-36	0	0		-84
34th St & 3rd Ave 2019 (TMC-018)	3								
34th St	3	EB	0	0	-37	0	0		
34th St	3	WB	0	0	-22	-2	0		
3rd Ave	3	NB	0	-6	-56	-5	0		
3rd Ave	3	SB	0	0	0	0	0		-128
35th St & 3rd Ave 2019 (TMC-019)	4								
35th St	4	EB	0	0	0	0	0		
35th St	4	WB	0	0	-39	-3	0		
3rd Ave	4	NB	0	-6	-52	0	0		
3rd Ave	4	SB	0	0	0	0	0		-100
34th St & 2nd Ave 2019 (TMC-020)	5								
34th St	5	EB	0	0	-11	-2	0		
34th St	5	WB	0	0	-4	0	0		
2nd Ave	5	NB	0	0	0	0	0		
2nd Ave	5	SB	0	-7	-31	-3	0		-58
35th St & 2nd Ave 2019 (TMC-021)	6								
35th St	6	EB	0	0	0	-5	0		
35th St	6	WB	0	-1	-1	0	0		
2nd Ave	6	NB	0	0	0	0	0		
2nd Ave	6	SB	0	0	-35	-3	0		-45

CBD Tolling
QMT - Traffic Flowmap
LN Action Increment



- Legend:**
- 1 - Intersection (2019 Collected Data)
 - 7 - Intersection (Uncollected Data)
 - 100 - ATR Volume
 - 100 - Approach Volume

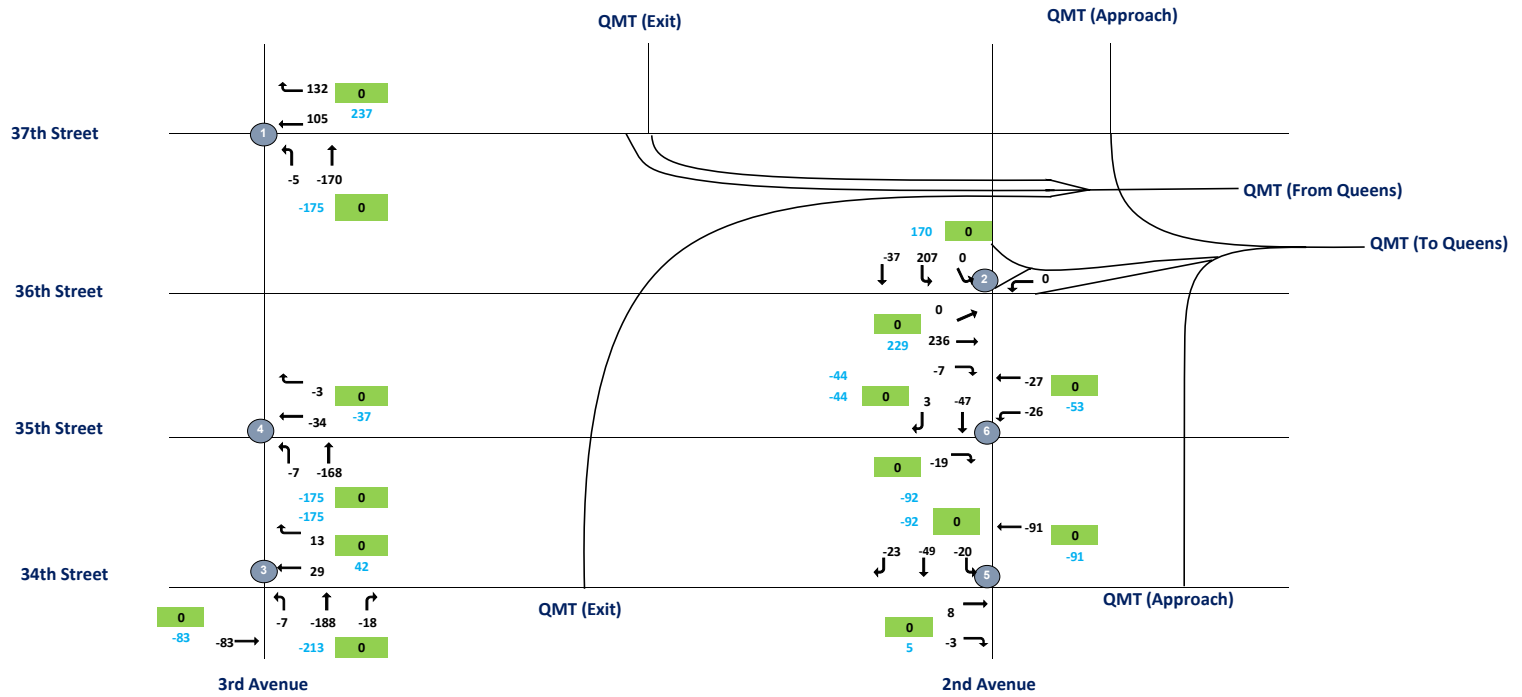

QM

9:00:00 PM

Intersection	Node	Approach	Balanced With-Action Increment					
			Inbound/Outbound					
			LN Peak Hour					
			L2	L	T	R	R2	Total
37th St & 3rd Ave 2019 (TMC-016)	1							
37th St	1	EB	0	0	0	0	0	
37th St	1	WB	0	0	105	132	0	
3rd Ave	1	NB	0	-5	-170	0	0	
3rd Ave	1	SB	0	0	0	0	0	62
36th St & 2nd Ave 2019 (TMC-017)	2							
36th St	2	EB	0	0	236	-7	0	
36th St	2	WB	0	0	0	0	0	
2nd Ave	2	NB	0	0	0	0	0	
2nd Ave	2	SB	0	207	-37	0	0	399
34th St & 3rd Ave 2019 (TMC-018)	3							
34th St	3	EB	0	0	-83	0	0	
34th St	3	WB	0	0	29	13	0	
3rd Ave	3	NB	0	-7	-188	-18	0	
3rd Ave	3	SB	0	0	0	0	0	-254
35th St & 3rd Ave 2019 (TMC-019)	4							
35th St	4	EB	0	0	0	0	0	
35th St	4	WB	0	0	-34	-3	0	
3rd Ave	4	NB	0	-7	-168	0	0	
3rd Ave	4	SB	0	0	0	0	0	-212
34th St & 2nd Ave 2019 (TMC-020)	5							
34th St	5	EB	0	0	8	-3	0	
34th St	5	WB	0	0	-91	0	0	
2nd Ave	5	NB	0	0	0	0	0	
2nd Ave	5	SB	0	-20	-49	-23	0	-178
35th St & 2nd Ave 2019 (TMC-021)	6							
35th St	6	EB	0	0	0	-19	0	
35th St	6	WB	0	-26	-27	0	0	
2nd Ave	6	NB	0	0	0	0	0	
2nd Ave	6	SB	0	0	-47	3	0	-116

CBD Tolling
QMT - Traffic Flowmap
MD Action Increment



- Legend:**
- 1 - Intersection (2019 Collected Data)
 - 7 - Intersection (Uncollected Data)
 - 100 - ATR Volume
 - 100 - Approach Volume

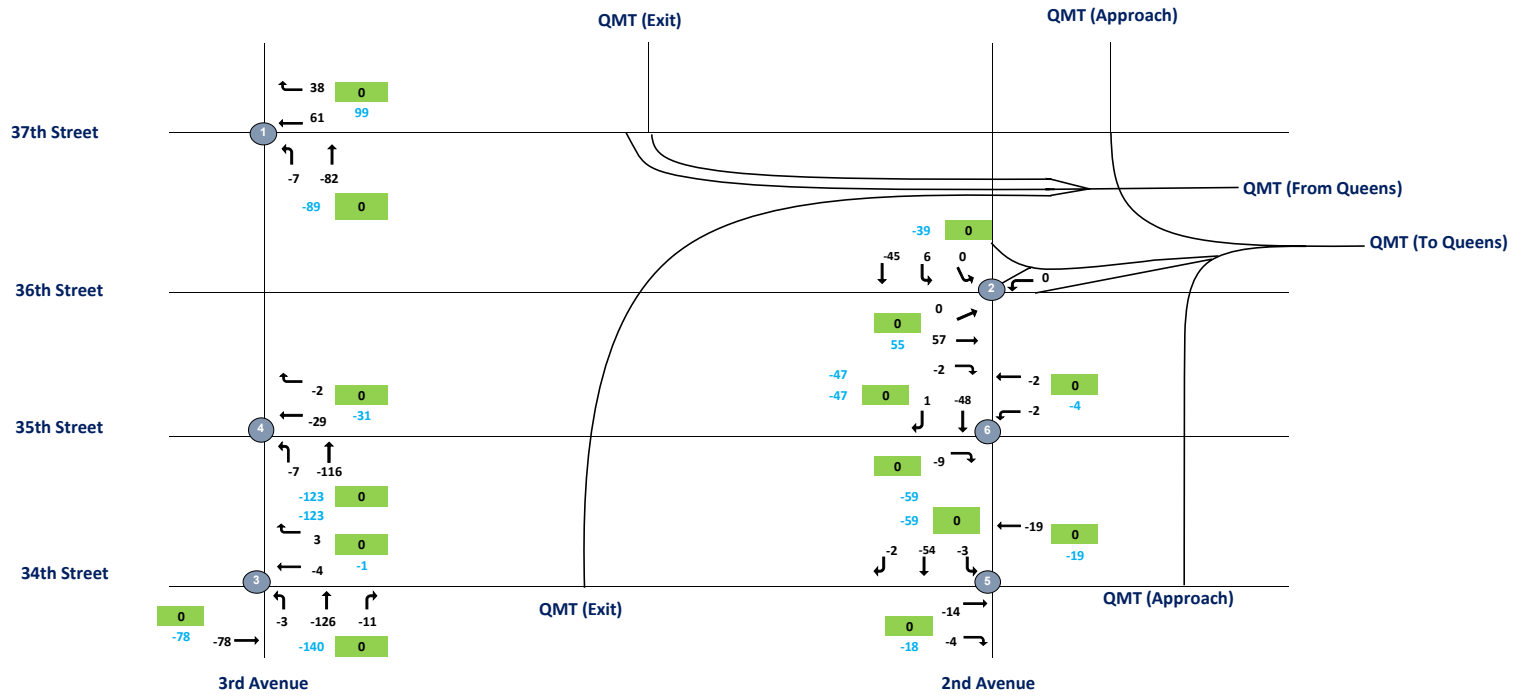

QM

1:00:00 PM

Intersection	Node	Approach	Balanced With-Action Increment					
			Inbound/Outbound					Total
			MD Peak Hour					
L2	L	T	R	R2				
37th St & 3rd Ave 2019 (TMC-016)	1							
37th St	1	EB	0	0	0	0	0	
37th St	1	WB	0	0	61	38	0	
3rd Ave	1	NB	0	-7	-82	0	0	
3rd Ave	1	SB	0	0	0	0	0	10
36th St & 2nd Ave 2019 (TMC-017)	2							
36th St	2	EB	0	0	57	-2	0	
36th St	2	WB	0	0	0	0	0	
2nd Ave	2	NB	0	0	0	0	0	
2nd Ave	2	SB	0	6	-45	0	0	16
34th St & 3rd Ave 2019 (TMC-018)	3							
34th St	3	EB	0	0	-78	0	0	
34th St	3	WB	0	0	-4	3	0	
3rd Ave	3	NB	0	-3	-126	-11	0	
3rd Ave	3	SB	0	0	0	0	0	-219
35th St & 3rd Ave 2019 (TMC-019)	4							
35th St	4	EB	0	0	0	0	0	
35th St	4	WB	0	0	-29	-2	0	
3rd Ave	4	NB	0	-7	-116	0	0	
3rd Ave	4	SB	0	0	0	0	0	-154
34th St & 2nd Ave 2019 (TMC-020)	5							
34th St	5	EB	0	0	-14	-4	0	
34th St	5	WB	0	0	-19	0	0	
2nd Ave	5	NB	0	0	0	0	0	
2nd Ave	5	SB	0	-3	-54	-2	0	-96
35th St & 2nd Ave 2019 (TMC-021)	6							
35th St	6	EB	0	0	0	-9	0	
35th St	6	WB	0	-2	-2	0	0	
2nd Ave	6	NB	0	0	0	0	0	
2nd Ave	6	SB	0	0	-48	1	0	-60

CBD Tolling
QMT - Traffic Flowmap
PM Action Increment



- Legend:**
- 1 - Intersection (2019 Collected Data)
 - 7 - Intersection (Uncollected Data)
 - 100 - ATR Volume
 - 100 - Approach Volume

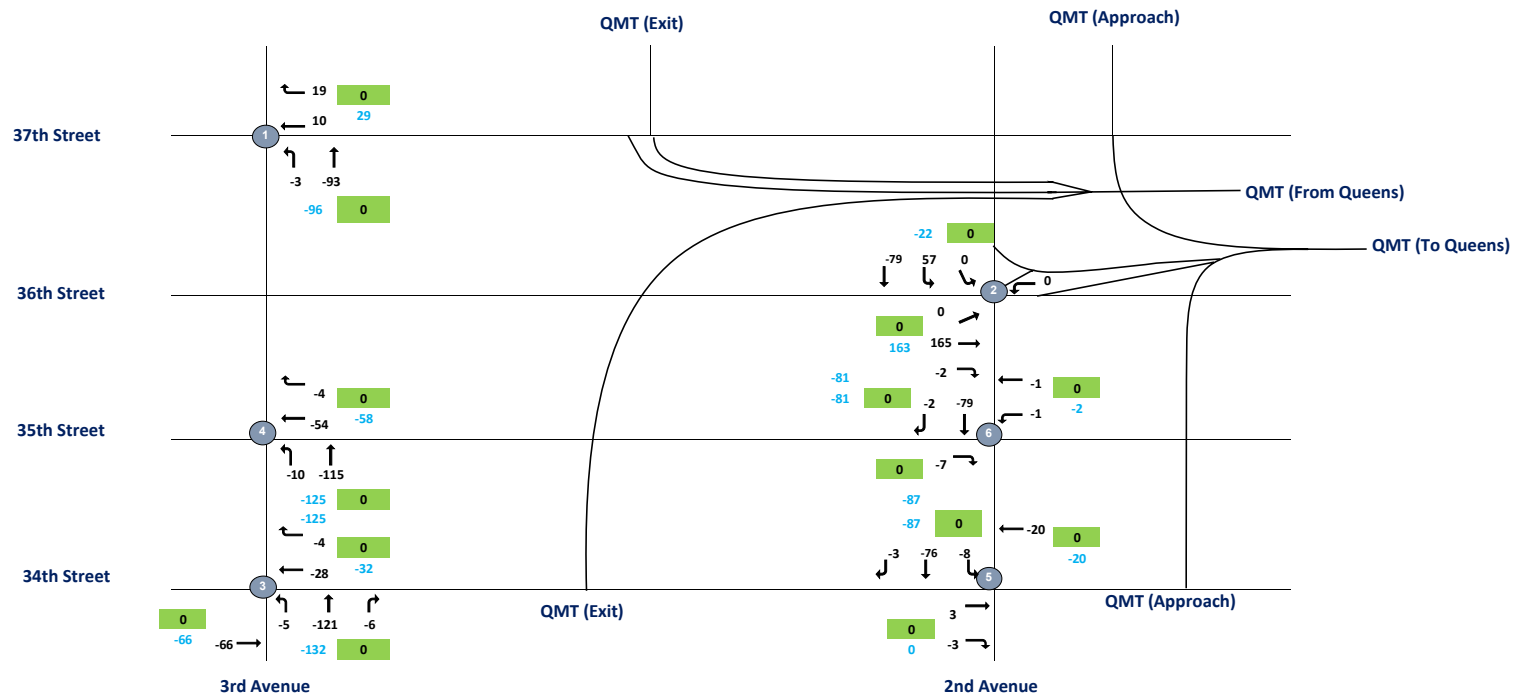

QM

5:00:00 PM

Intersection	Node	Approach	Balanced With-Action Increment						
			Inbound/Outbound						
			PM Peak Hour						
			L2	L	T	R	R2	Total	
37th St & 3rd Ave 2019 (TMC-016)	1								
37th St	1	EB	0	0	0	0	0		
37th St	1	WB	0	0	10	19	0		
3rd Ave	1	NB	0	-3	-93	0	0		
3rd Ave	1	SB	0	0	0	0	0		-67
36th St & 2nd Ave 2019 (TMC-017)	2								
36th St	2	EB	0	0	165	-2	0		
36th St	2	WB	0	0	0	0	0		
2nd Ave	2	NB	0	0	0	0	0		
2nd Ave	2	SB	0	57	-79	0	0		141
34th St & 3rd Ave 2019 (TMC-018)	3								
34th St	3	EB	0	0	-66	0	0		
34th St	3	WB	0	0	-28	-4	0		
3rd Ave	3	NB	0	-5	-121	-6	0		
	3	SB	0	0	0	0	0		-230
35th St & 3rd Ave 2019 (TMC-019)	4								
35th St	4	EB	0	0	0	0	0		
35th St	4	WB	0	0	-54	-4	0		
3rd Ave	4	NB	0	-10	-115	0	0		
	4	SB	0	0	0	0	0		-183
34th St & 2nd Ave 2019 (TMC-020)	5								
34th St	5	EB	0	0	3	-3	0		
34th St	5	WB	0	0	-20	0	0		
2nd Ave	5	NB	0	0	0	0	0		
2nd Ave	5	SB	0	-8	-76	-3	0		-107
35th St & 2nd Ave 2019 (TMC-021)	6								
35th St	6	EB	0	0	0	-7	0		
35th St	6	WB	0	-1	-1	0	0		
2nd Ave	6	NB	0	0	0	0	0		
2nd Ave	6	SB	0	0	-79	-2	0		-90

CBD Tolling
RKB - Traffic Flowmap
AM Action Increment



- Legend:**
- Intersection (2019 Collected Data)
 - Intersection (Uncollected Data)
 - ATR Volume
 - Approach Volume

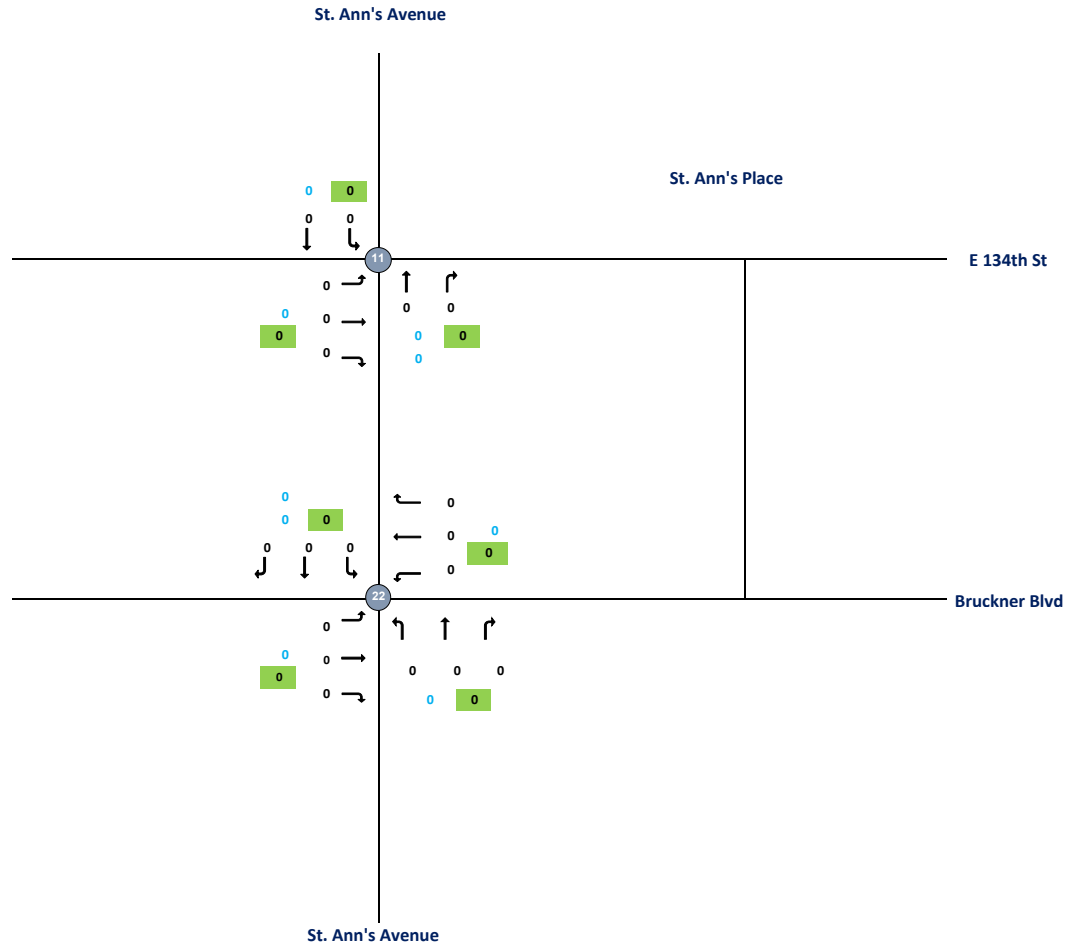

RKB

8:00 AM

Intersection	Node	Approach	Total Vehicles						
			Inbound/Outbound						
			AM Peak Hour						
			L2	L	T	R	R2	Total	
E 134th Street and St. Ann's Ave 2019 (TMC-060)	11								
E 134th Street	11	EB	0	0	0	0	0		
E 134th Street	11	WB	0	0	0	0	0		
St. Ann's Ave	11	NB	0	0	0	0	0		
St. Ann's Ave	11	SB	0	0	0	0	0	0	
Bruckner Blvd and St. Ann's Ave 2019 (TMC-061)	22								
Bruckner Blvd	22	EB	0	0	0	0	0		
Bruckner Blvd	22	WB	0	0	0	0	0		
St. Ann's Ave	22	NB	0	0	0	0	0		
St. Ann's Ave	22	SB	0	0	0	0	0	0	

CBD Tolling
AS - Traffic Flowmap
AM Action Increment



- Legend:**
- 1 - Intersection (2019 Collected Data)
 - 7 - Intersection (Uncollected Data)
 - 100 - ATR Volume
 - 100 - Approach Volume

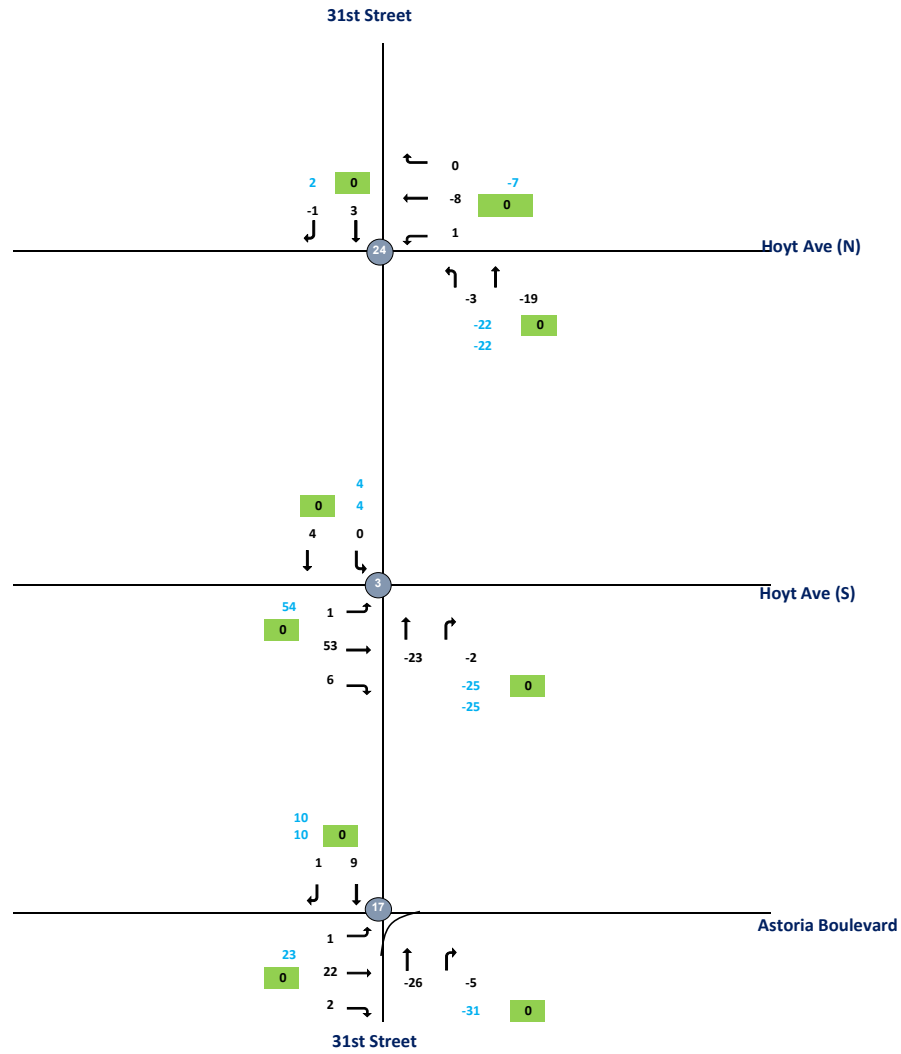

AS

7:15:00 AM

Intersection	Node	Approach	Total Vehicles						
			Inbound/Outbound						
			AM Peak Hour						
			L2	L	T	R	R2	Total	
31st Street and Astoria Blvd 2019 (TMC-062)	17								
Astoria Blvd	17	EB	0	1	22	2	0		
Astoria Blvd	17	WB	0	0	0	0	0		
31st Street	17	NB	0	0	-26	-5	0		
31st Street	17	SB	0	0	9	1	0		4
31st Street and Hoyt Ave N 2019 (TMC-063)	24								
Hoyt Ave N	24	EB	0	0	0	0	0		
Hoyt Ave N	24	WB	0	1	-8	0	0		
31st Street	24	NB	0	-3	-19	0	0		
31st Street	24	SB	0	0	3	-1	0		-27
31st Street and Hoyt Ave S 2019 (TMC-064)	3								
Hoyt Ave S	3	EB	0	1	53	6	0		
	3		0	0	0	0	0		
31st Street	3	NB	0	0	-23	-2	0		
31st Street	3	SB	0	0	4	0	0		39

CBD Tolling
RKM - Traffic Flowmap
AM Action Increment



- Legend:**
- 1 - Intersection (2019 Collected Data)
 - 7 - Intersection (Uncollected Data)
 - 100 - ATR Volume
 - 100 - Approach Volume

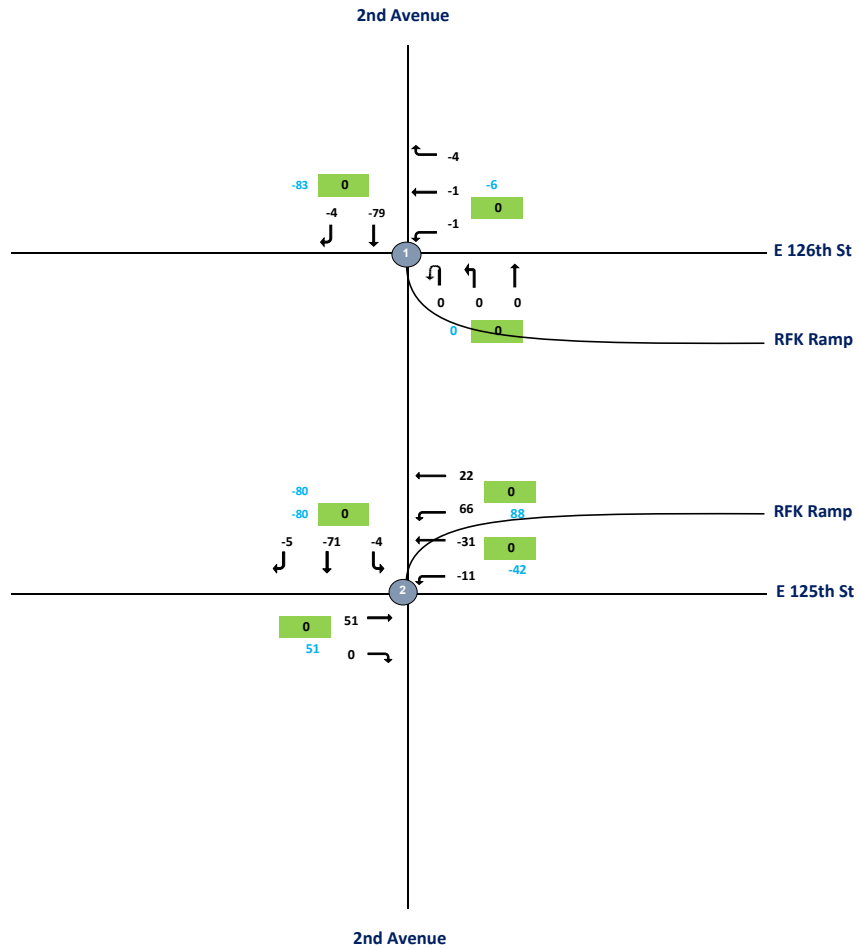

RKM

7:45 AM

Intersection	Node	Approach	Total Vehicles						Total
			Inbound/Outbound						
			AM Peak Hour						
			L2	L	T	R	R2		
E 126th Street and 2nd Ave									
2019 (TMC-058)									
RFK Ramp	1	NW	0	0	0	0	0		
E 126th Street	1	EB	0	0	0	0	0		
E 126th Street	1	WB	0	-1	-1	-4	0		
2nd Ave	1	NB	0	0	0	0	0		
2nd Ave	1	SB	0	0	-79	-4	0	-89	
E 125th Street and 2nd Ave									
2019 (TMC-059)									
E 125th Street	2	EB	0	0	51	0	0		
E 125th Street	2	WB	0	-11	-31	0	0		
2nd Ave	2	SW	0	66	0	22	0		
2nd Ave	2	SB	0	-4	-71	-5	0	17	

CBD Tolling
RKB - Traffic Flowmap
MD Action Increment



- Legend:**
- Intersection (2019 Collected Data)
 - Intersection (Uncollected Data)
 - ATR Volume
 - Approach Volume

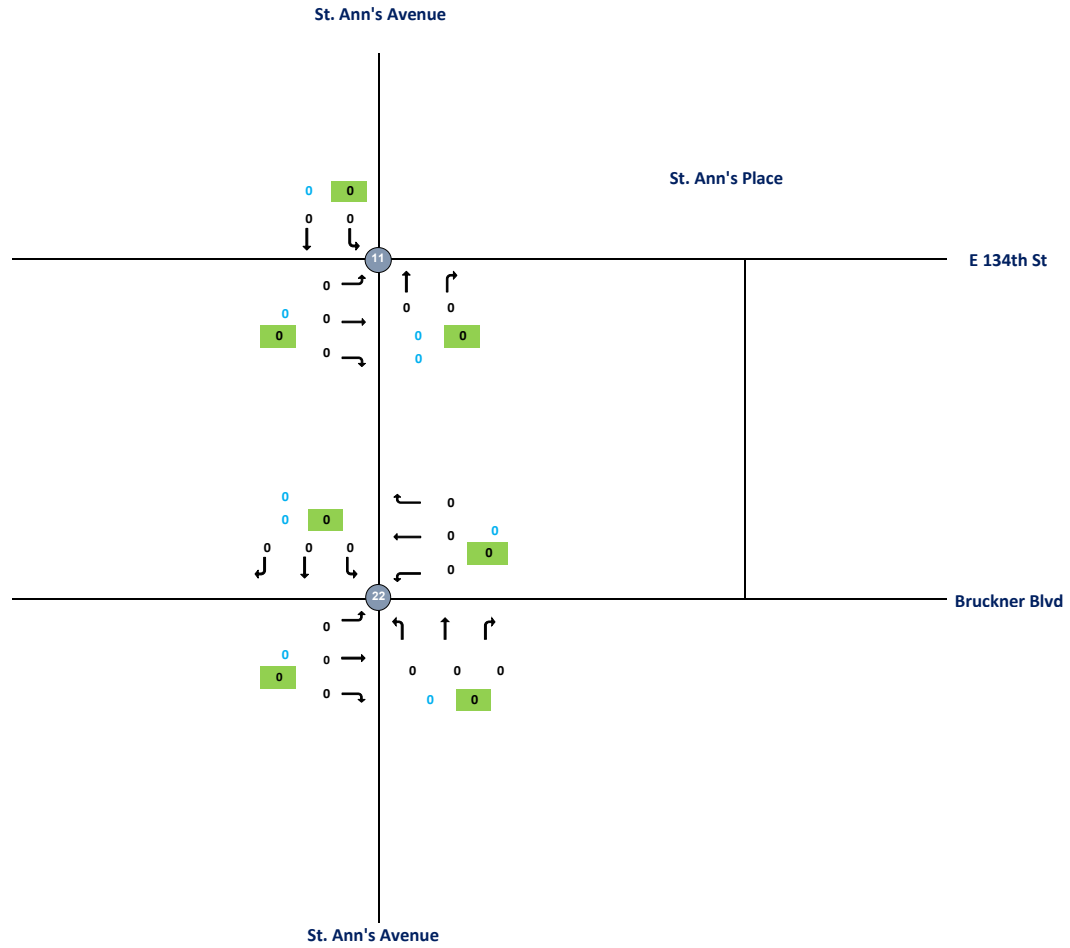

RKB

1:00 PM

Intersection	Node	Approach	Total Vehicles						
			Inbound/Outbound						
			MD Peak Hour						
			L2	L	T	R	R2	Total	
E 134th Street and St. Ann's Ave 2019 (TMC-060)	11								
E 134th Street	11	EB	0	0	0	0	0		
E 134th Street	11	WB	0	0	0	0	0		
St. Ann's Ave	11	NB	0	0	0	0	0		
St. Ann's Ave	11	SB	0	0	0	0	0		0
Bruckner Blvd and St. Ann's Ave 2019 (TMC-061)	22								
Bruckner Blvd	22	EB	0	0	0	0	0		
Bruckner Blvd	22	WB	0	0	0	0	0		
St. Ann's Ave	22	NB	0	0	0	0	0		
St. Ann's Ave	22	SB	0	0	0	0	0		0

CBD Tolling
AS - Traffic Flowmap
MD Action Increment



- Legend:**
- 1 - Intersection (2019 Collected Data)
 - 7 - Intersection (Uncollected Data)
 - 100 - ATR Volume
 - 100 - Approach Volume

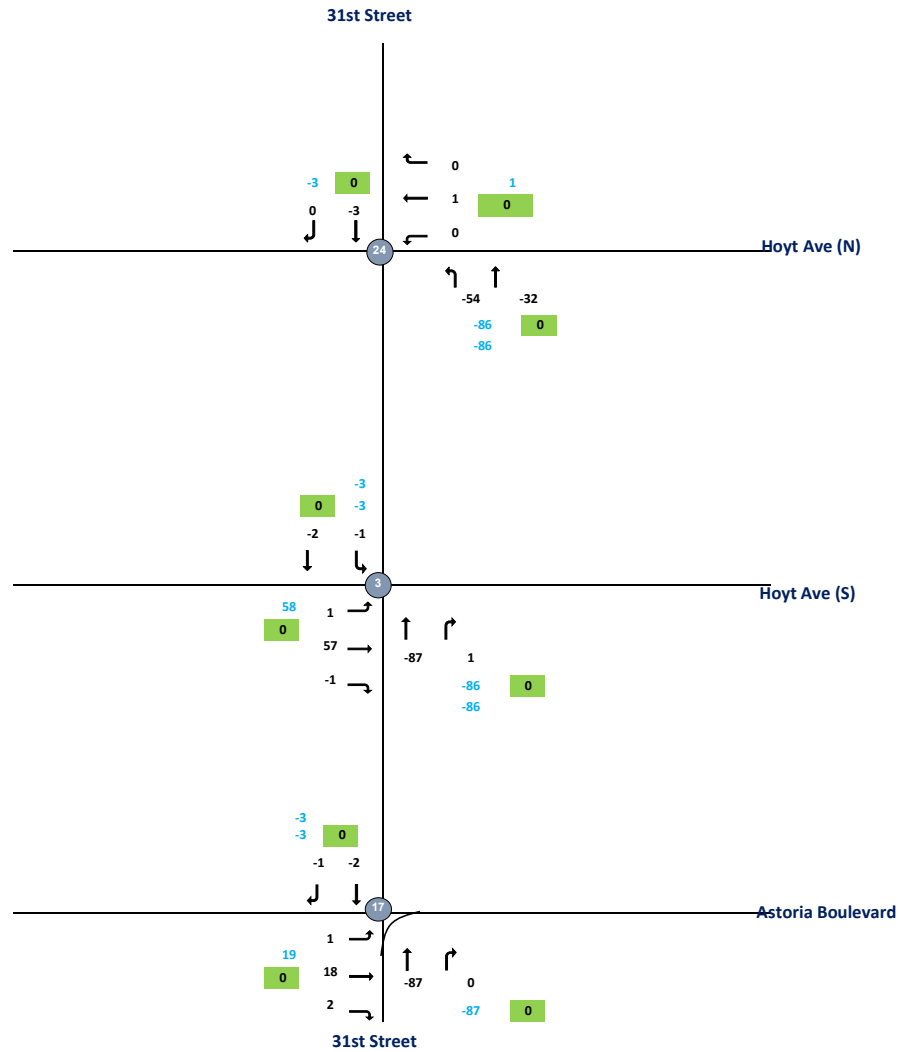

AS

12:30:00 PM

Intersection	Node	Approach	Total Vehicles						
			Inbound/Outbound						
			MD Peak Hour						
			L2	L	T	R	R2	Total	
31st Street and Astoria Blvd 2019 (TMC-062)	17								
Astoria Blvd	17	EB	0	1	18	2	0		
Astoria Blvd	17	WB	0	0	0	0	0		
31st Street	17	NB	0	0	-87	0	0		
31st Street	17	SB	0	0	-2	-1	0		-69
31st Street and Hoyt Ave N 2019 (TMC-063)	24								
Hoyt Ave N	24	EB	0	0	0	0	0		
Hoyt Ave N	24	WB	0	0	1	0	0		
31st Street	24	NB	0	-54	-32	0	0		
31st Street	24	SB	0	0	-3	0	0		-88
31st Street and Hoyt Ave S 2019 (TMC-064)	3								
Hoyt Ave S	3	EB	0	1	57	-1	0		
	3		0	0	0	0	0		
31st Street	3	NB	0	0	-87	1	0		
31st Street	3	SB	0	-1	-2	0	0		-32

CBD Tolling
RKM - Traffic Flowmap
MD Action Increment



- Legend:**
- 1 - Intersection (2019 Collected Data)
 - 7 - Intersection (Uncollected Data)
 - 100 - ATR Volume
 - 100 - Approach Volume

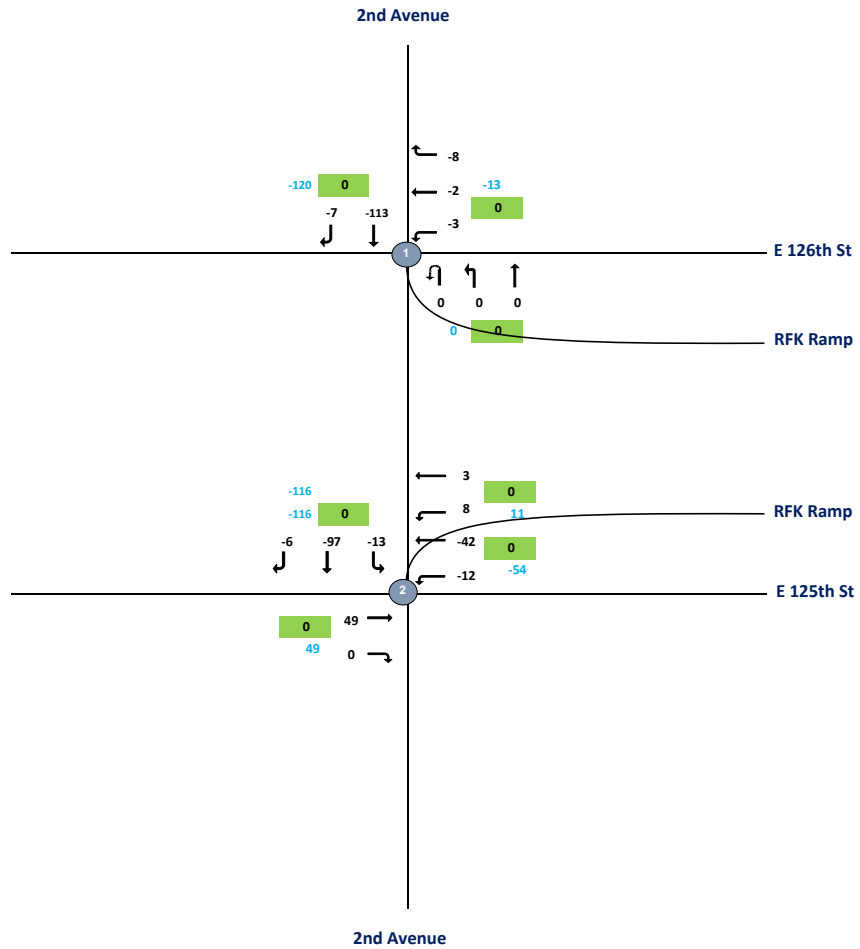

RKM

1:00 PM

Intersection	Node	Approach	Total Vehicles					Total
			Inbound/Outbound					
			MD Peak Hour					
			L2	L	T	R	R2	
E 126th Street and 2nd Ave								
2019 (TMC-058)								
RFK Ramp	1	NW	0	0	0	0	0	
E 126th Street	1	EB	0	0	0	0	0	
E 126th Street	1	WB	0	-3	-2	-8	0	
2nd Ave	1	NB	0	0	0	0	0	
2nd Ave	1	SB	0	0	-113	-7	0	-133
E 125th Street and 2nd Ave								
2019 (TMC-059)								
E 125th Street	2	EB	0	0	49	0	0	
E 125th Street	2	WB	0	-12	-42	0	0	
2nd Ave	2	SW	0	8	0	3	0	
2nd Ave	2	SB	0	-13	-97	-6	0	-110

CBD Tolling
RKB - Traffic Flowmap
PM Action Increment



- Legend:**
- ① - Intersection (2019 Collected Data)
 - ⑦ - Intersection (Uncollected Data)
 - 100 - ATR Volume
 - 100 - Approach Volume

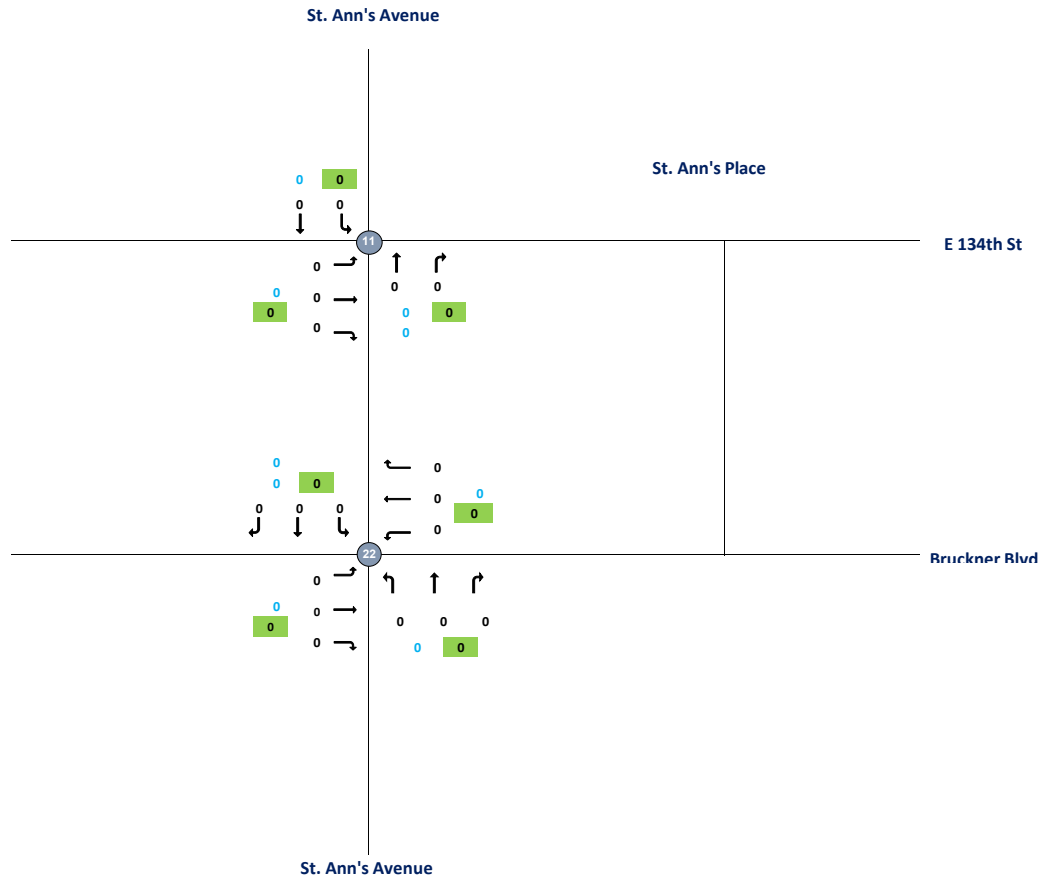

RKB

5:00 PM

Intersection	Node	Approach	Total Vehicles						
			Inbound/Outbound						
			PM Peak Hour						
			L2	L	T	R	R2	Total	
E 134th Street and St. Ann's Ave 2019 (TMC-060)	11								
E 134th Street	11	EB	0	0	0	0	0		
E 134th Street	11	WB	0	0	0	0	0		
St. Ann's Ave	11	NB	0	0	0	0	0		
St. Ann's Ave	11	SB	0	0	0	0	0		0
Bruckner Blvd and St. Ann's Ave 2019 (TMC-061)	22								
Bruckner Blvd	22	EB	0	0	0	0	0		
Bruckner Blvd	22	WB	0	0	0	0	0		
St. Ann's Ave	22	NB	0	0	0	0	0		
St. Ann's Ave	22	SB	0	0	0	0	0		0

CBD Tolling
AS - Traffic Flowmap
PM Action Increment



- Legend:**
- 1 - Intersection (2019 Collected Data)
 - 7 - Intersection (Uncollected Data)
 - 100 - ATR Volume
 - 100 - Approach Volume

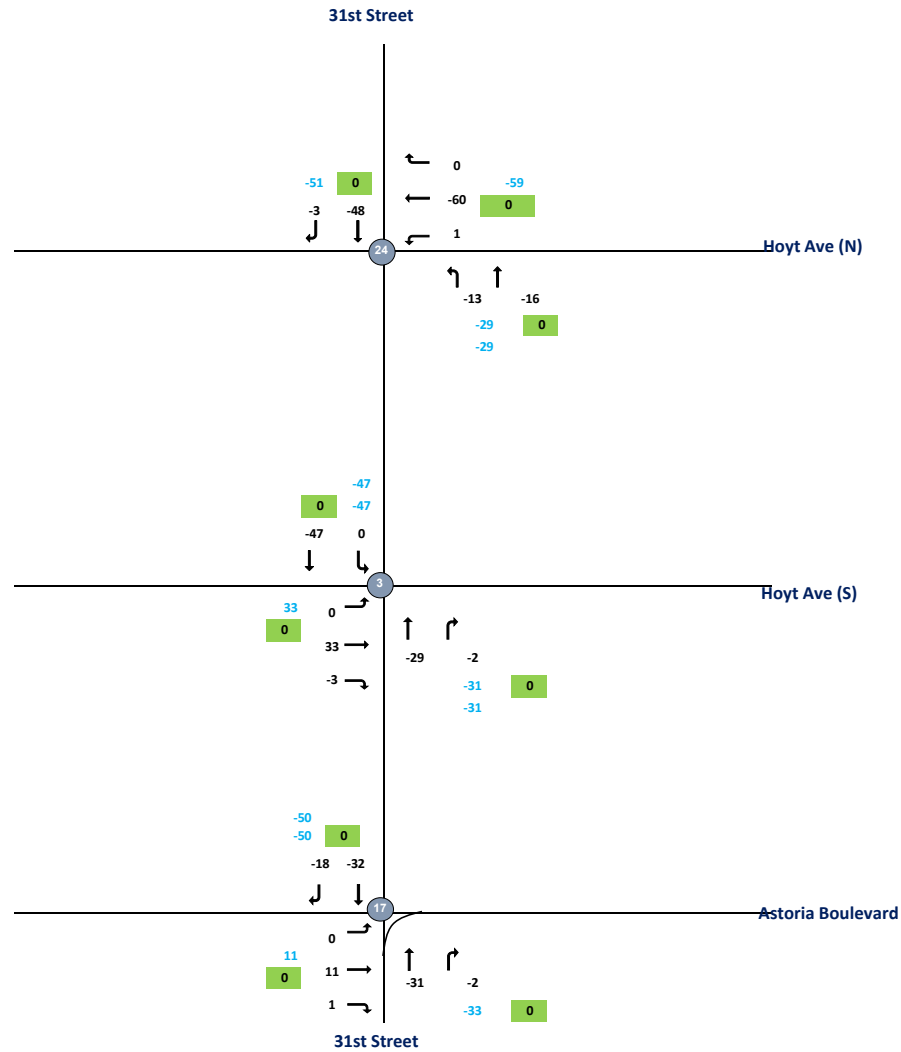

AS

5:00:00 PM

Intersection	Node	Approach	Total Vehicles					
			Inbound/Outbound					
			PM Peak Hour					
			L2	L	T	R	R2	Total
31st Street and Astoria Blvd 2019 (TMC-062)	17							
Astoria Blvd	17	EB	0	0	11	1	0	
Astoria Blvd	17	WB	0	0	0	0	0	
31st Street	17	NB	0	0	-31	-2	0	
31st Street	17	SB	0	0	-32	-18	0	-71
31st Street and Hoyt Ave N 2019 (TMC-063)	24							
Hoyt Ave N	24	EB	0	0	0	0	0	
Hoyt Ave N	24	WB	0	1	-60	0	0	
31st Street	24	NB	0	-13	-16	0	0	
31st Street	24	SB	0	0	-48	-3	0	-139
31st Street and Hoyt Ave S 2019 (TMC-064)	3							
Hoyt Ave S	3	EB	0	0	33	-3	0	
	3		0	0	0	0	0	
31st Street	3	NB	0	0	-29	-2	0	
31st Street	3	SB	0	0	-47	0	0	-48

CBD Tolling
RKM - Traffic Flowmap
PM Action Increment



- Legend:**
- 1 - Intersection (2019 Collected Data)
 - 7 - Intersection (Uncollected Data)
 - 100 - ATR Volume
 - 100 - Approach Volume

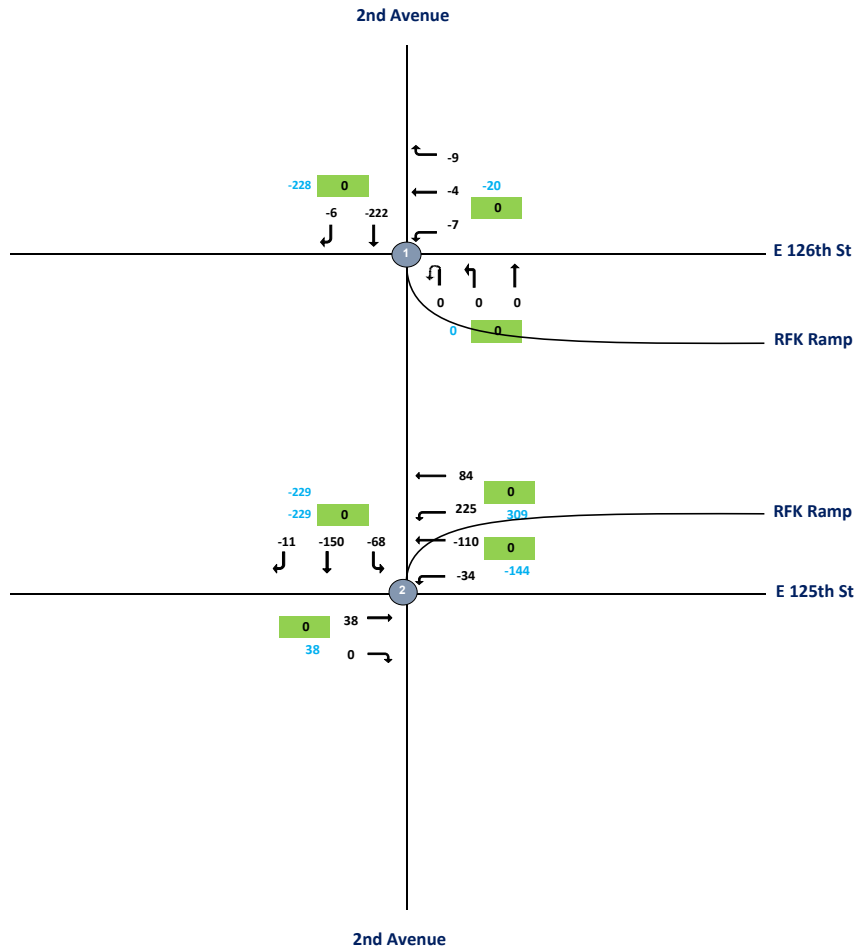

RKM

5:00 PM

Intersection	Node	Approach	Total Vehicles					Total
			Inbound/Outbound					
			PM Peak Hour					
			L2	L	T	R	R2	
E 126th Street and 2nd Ave								
2019 (TMC-058)								
RFK Ramp	1	NW	0	0	0	0	0	
E 126th Street	1	EB	0	0	0	0	0	
E 126th Street	1	WB	0	-7	-4	-9	0	
2nd Ave	1	NB	0	0	0	0	0	
2nd Ave	1	SB	0	0	-222	-6	0	-248
E 125th Street and 2nd Ave								
2019 (TMC-059)								
E 125th Street	2	EB	0	0	38	0	0	
E 125th Street	2	WB	0	-34	-110	0	0	
2nd Ave	2	SW	0	225	0	84	0	
2nd Ave	2	SB	0	-68	-150	-11	0	-26

CBD Tolling
RKB - Traffic Flowmap
LN Action Increment



- Legend:**
- 1 - Intersection (2019 Collected Data)
 - 7 - Intersection (Uncollected Data)
 - 100 - ATR Volume
 - 100 - Approach Volume

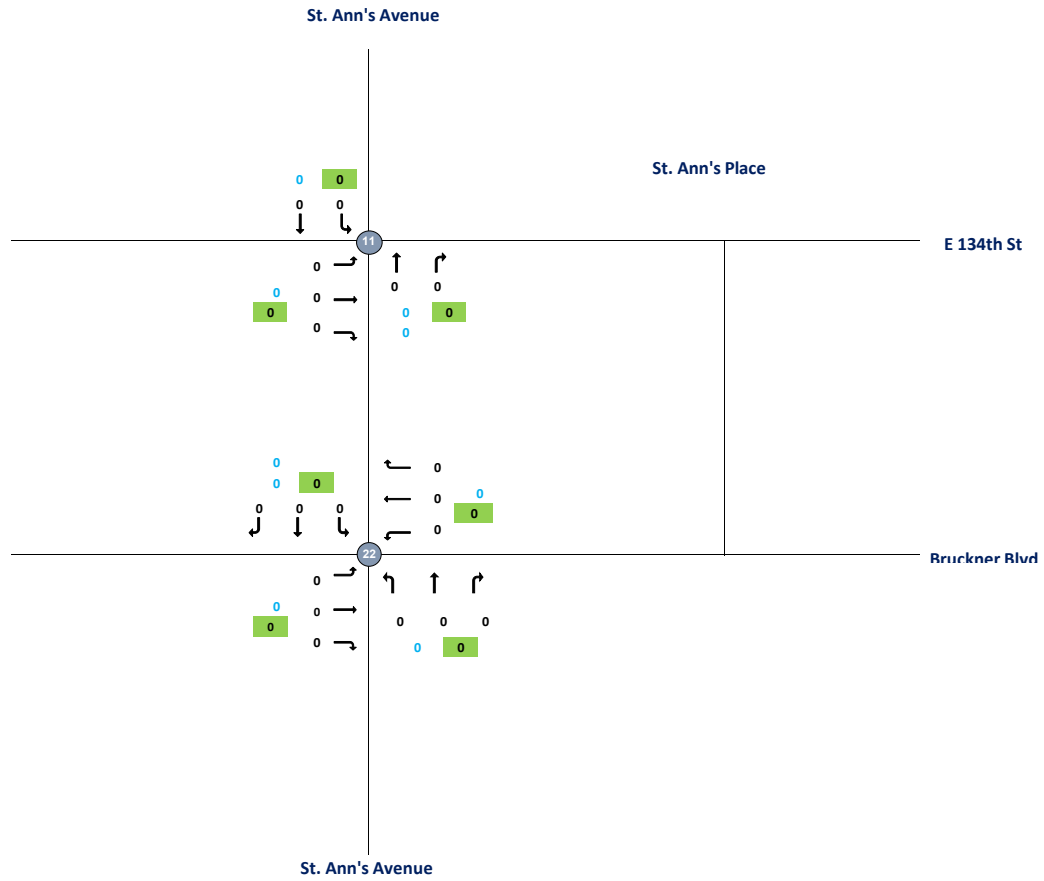

RKB

9:00 PM

Intersection	Node	Approach	Total Vehicles						
			Inbound/Outbound						
			LN Peak Hour						
			L2	L	T	R	R2	Total	
E 134th Street and St. Ann's Ave 2019 (TMC-060)	11								
E 134th Street	11	EB	0	0	0	0	0		
E 134th Street	11	WB	0	0	0	0	0		
St. Ann's Ave	11	NB	0	0	0	0	0		
St. Ann's Ave	11	SB	0	0	0	0	0		0
Bruckner Blvd and St. Ann's Ave 2019 (TMC-061)	22								
Bruckner Blvd	22	EB	0	0	0	0	0		
Bruckner Blvd	22	WB	0	0	0	0	0		
St. Ann's Ave	22	NB	0	0	0	0	0		
St. Ann's Ave	22	SB	0	0	0	0	0		0

CBD Tolling
AS - Traffic Flowmap
LN Action Increment



- Legend:
- 1 - Intersection (2019 Collected Data)
 - 7 - Intersection (Uncollected Data)
 - 100 - ATR Volume
 - 100 - Approach Volume

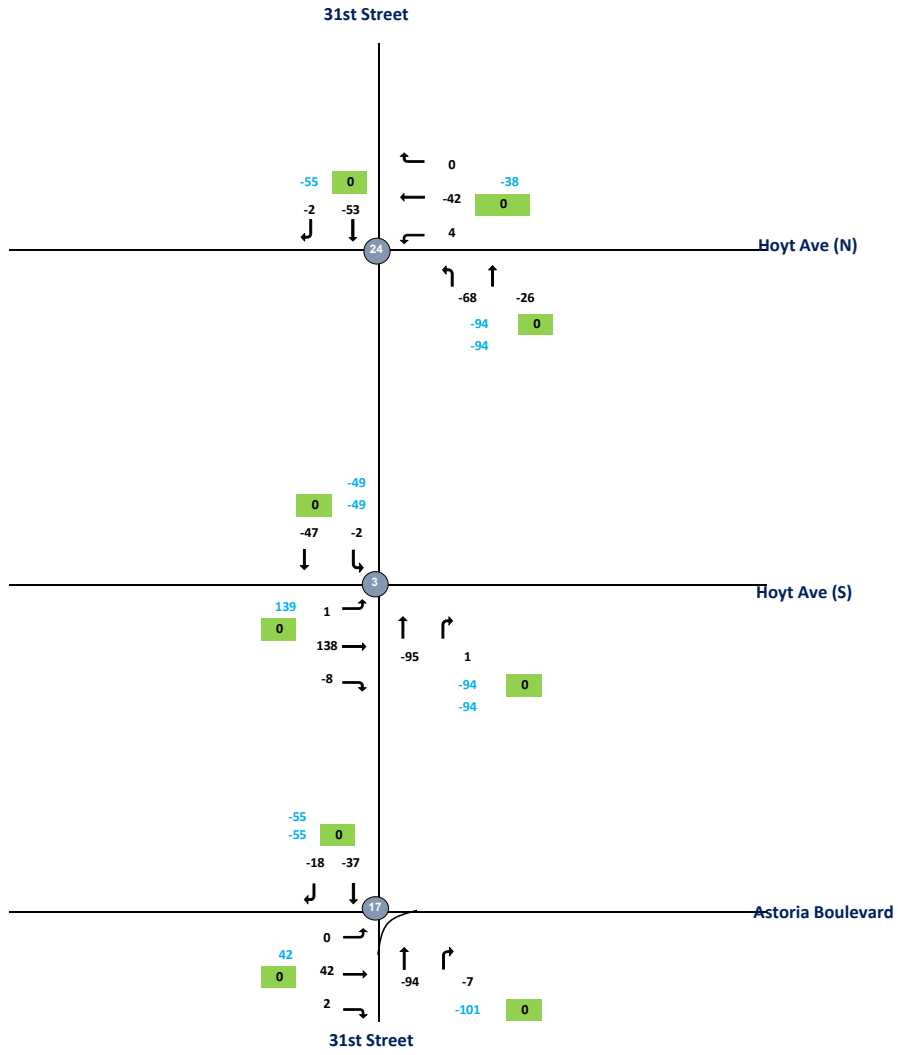

AS

9:00:00 PM

Intersection	Node	Approach	Total Vehicles					
			Inbound/Outbound					
			LN Peak Hour					
			L2	L	T	R	R2	Total
31st Street and Astoria Blvd 2019 (TMC-062)	17							
Astoria Blvd	17	EB	0	0	42	2	0	
Astoria Blvd	17	WB	0	0	0	0	0	
31st Street	17	NB	0	0	-94	-7	0	
31st Street	17	SB	0	0	-37	-18	0	-112
31st Street and Hoyt Ave N 2019 (TMC-063)	24							
Hoyt Ave N	24	EB	0	0	0	0	0	
Hoyt Ave N	24	WB	0	4	-42	0	0	
31st Street	24	NB	0	-68	-26	0	0	
31st Street	24	SB	0	0	-53	-2	0	-187
31st Street and Hoyt Ave S 2019 (TMC-064)	3							
Hoyt Ave S	3	EB	0	1	138	-8	0	
	3		0	0	0	0	0	
31st Street	3	NB	0	0	-95	1	0	
31st Street	3	SB	0	-2	-47	0	0	-12

CBD Tolling
RKM - Traffic Flowmap
LN Action Increment



- Legend:**
- 1 - Intersection (2019 Collected Data)
 - 7 - Intersection (Uncollected Data)
 - 100 - ATR Volume
 - 100 - Approach Volume

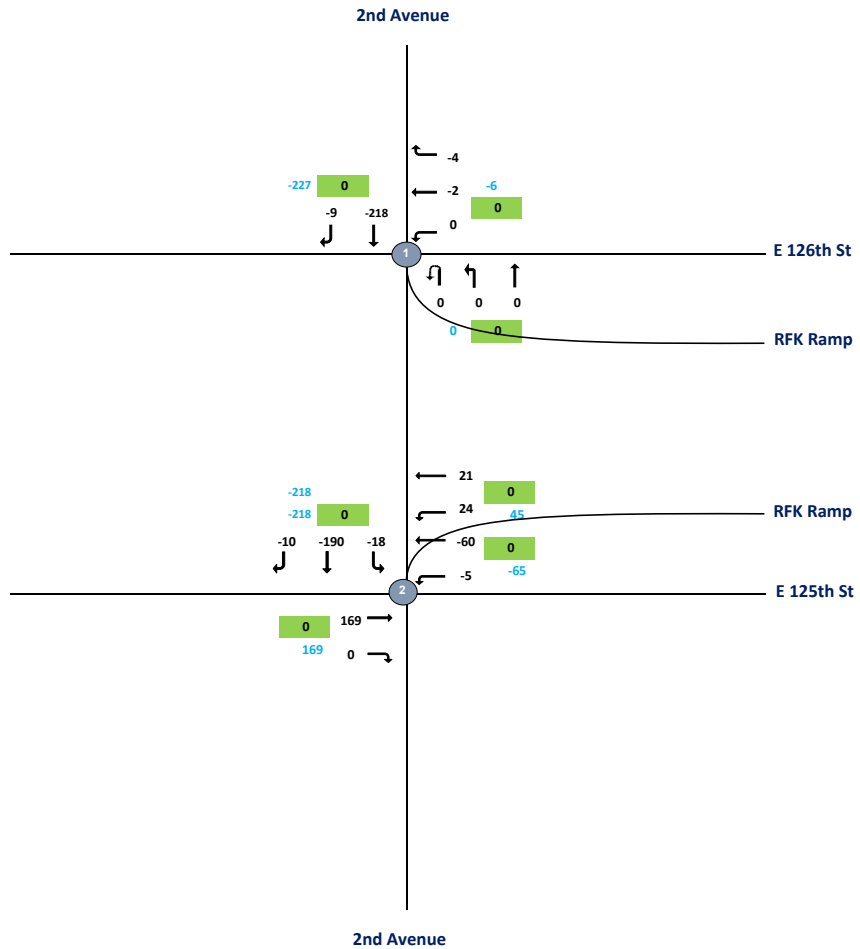

RKM

9:00 PM

Intersection	Node	Approach	Total Vehicles					Total
			Inbound/Outbound					
			LN Peak Hour					
			L2	L	T	R	R2	
E 126th Street and 2nd Ave								
2019 (TMC-058)								
RFK Ramp	1	NW	0	0	0	0	0	
E 126th Street	1	EB	0	0	0	0	0	
E 126th Street	1	WB	0	0	-2	-4	0	
2nd Ave	1	NB	0	0	0	0	0	
2nd Ave	1	SB	0	0	-218	-9	0	-233
E 125th Street and 2nd Ave								
2019 (TMC-059)								
E 125th Street	2	EB	0	0	169	0	0	
E 125th Street	2	WB	0	-5	-60	0	0	
2nd Ave	2	SW	0	24	0	21	0	
2nd Ave	2	SB	0	-18	-190	-10	0	-69

CBD Tolling
Red Hook- Traffic Flowmap
AM Increment



- Legend:**
- 1 - Intersection (2019 Collected Data)
 - 2 - Intersection (Uncollected Data)
 - 100 - ATR Volume
 - 100 - Approach Volume

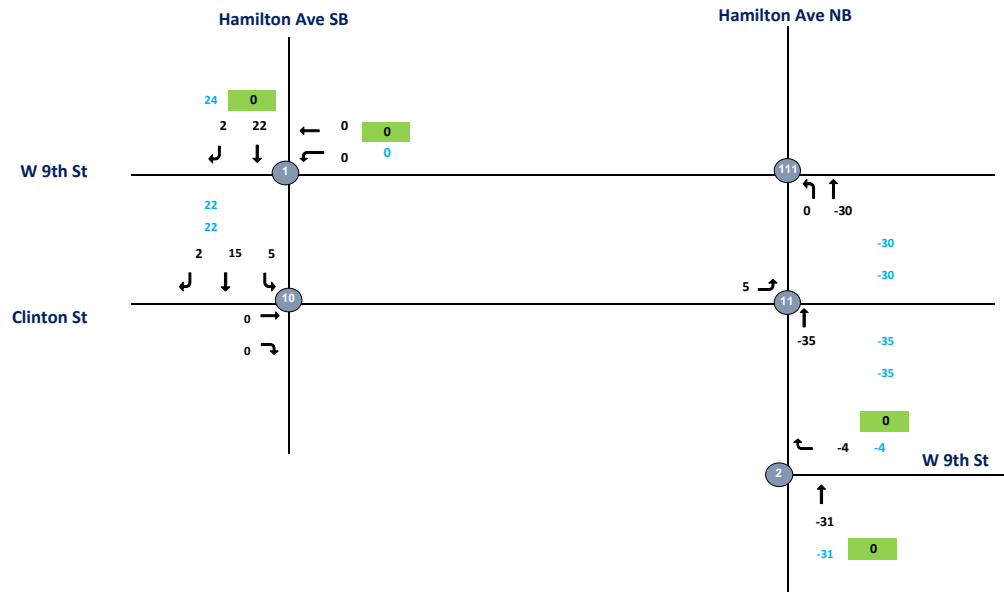

RH

7:45:00 AM

Intersection	Node	Approach	Balanced With-Action Increment					
			Inbound/Outbound					Total
			L2	L	T	R	R2	
Hamilton Ave SB & W 9th St 2019 (TMC-040)	1							
W 9th St	1	EB	0	0	0	0	0	
W 9th St	1	WB	0	0	0	0	0	
Hamilton Ave SB	1		0	0	0	0	0	
Hamilton Ave SB	1	SB	0	0	22	2	0	24
Hamilton Ave SB & W 9th St 2019 (TMC-040)	10							
Clinton Avenue	10	EB	0	0	0	0	0	
Clinton Avenue	10	WB	0	0	0	0	0	
Hamilton Ave SB	10		0	0	0	0	0	
Hamilton Ave SB	10	SB	0	5	15	2	0	22
Hamilton Ave SB & W 9th St 2019 (TMC-040)	11							
Clinton Avenue	11	EB	0	5	0	0	0	
Clinton Avenue	11		0	0	0	0	0	
Hamilton Ave	11	NB	0	0	-35	0	0	
Hamilton Ave	11		0	0	0	0	0	-30
Hamilton Ave SB & W 9th St 2019 (TMC-040)	111							
W 9th St	111	EB	0	0	0	0	0	
W 9th St	111	WB	0	0	0	0	0	
Hamilton Ave	111	NB	0	0	-30	0	0	
-	111	SB	0	0	0	0	0	-30
Hamilton Ave NB & W 9th St 2019 (TMC-041)	2							
W 9th St	2	EB	0	0	0	0	0	
W 9th St	2	WB	0	0	0	-4	0	
Hamilton Ave	2	NB	0	0	-31	0	0	
Hamilton Ave	2	SB	0	0	0	0	0	-35

CBD Tolling
Red Hook- Traffic Flowmap
MD Action Increment



- Legend:**
- 1 - Intersection (2019 Collected Data)
 - 7 - Intersection (Uncollected Data)
 - 100 - ATR Volume
 - 100 - Approach Volume

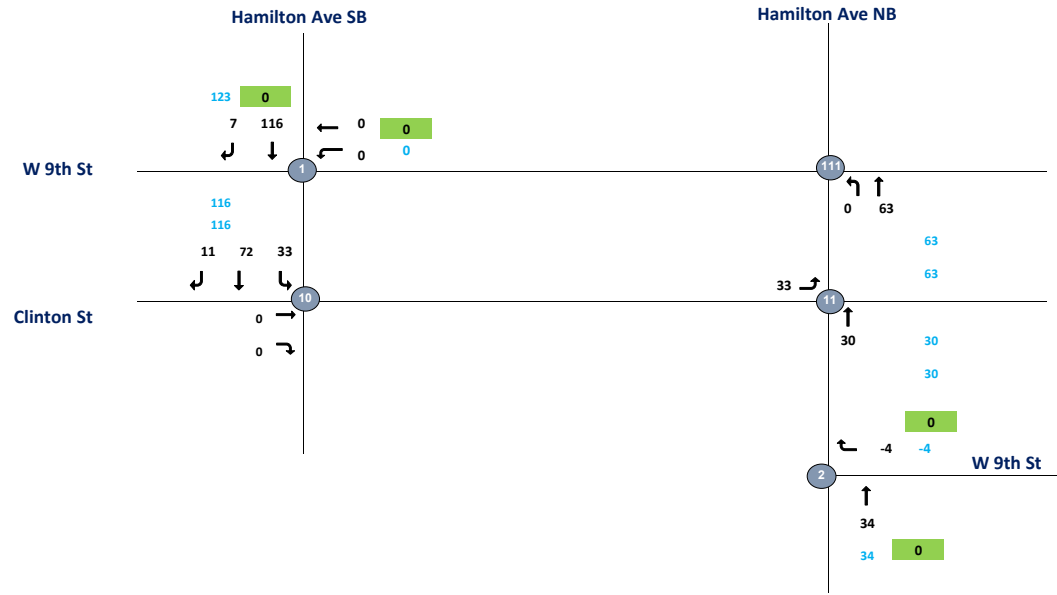

RH

12:00:00 PM

Intersection	Node	Approach	Balanced With-Action Increment					Total	
			Inbound/Outbound						
			MD Peak Hour						
			L2	L	T	R	R2		
Hamilton Ave SB & W 9th St 2019 (TMC-040)	1								
W 9th St	1	EB	0	0	0	0	0		
W 9th St	1	WB	0	0	0	0	0		
Hamilton Ave SB	1		0	0	0	0	0		
Hamilton Ave SB	1	SB	0	0	116	7	0		123
Hamilton Ave SB & W 9th St 2019 (TMC-040)	10								
Clinton Avenue	10	EB	0	0	0	0	0		
Clinton Avenue	10	WB	0	0	0	0	0		
Hamilton Ave SB	10		0	0	0	0	0		
Hamilton Ave SB	10	SB	0	33	72	11	0		116
Hamilton Ave SB & W 9th St 2019 (TMC-040)	11								
Clinton Avenue	11	EB	0	33	0	0	0		
Clinton Avenue	11		0	0	0	0	0		
Hamilton Ave	11	NB	0	0	30	0	0		
Hamilton Ave	11		0	0	0	0	0		63
Hamilton Ave SB & W 9th St 2019 (TMC-040)	111								
W 9th St	111	EB	0	0	0	0	0		
W 9th St	111	WB	0	0	0	0	0		
Hamilton Ave	111	NB	0	0	63	0	0		
-	111	SB	0	0	0	0	0		63
Hamilton Ave NB & W 9th St 2019 (TMC-041)	2								
W 9th St	2	EB	0	0	0	0	0		
W 9th St	2	WB	0	0	0	-4	0		
Hamilton Ave	2	NB	0	0	34	0	0		
Hamilton Ave	2	SB	0	0	0	0	0		30

CBD Tolling
Red Hook- Traffic Flowmap
PM Action Increment



- Legend:**
- 1 - Intersection (2019 Collected Data)
 - 7 - Intersection (Uncollected Data)
 - 100 - ATR Volume
 - 100 - Approach Volume

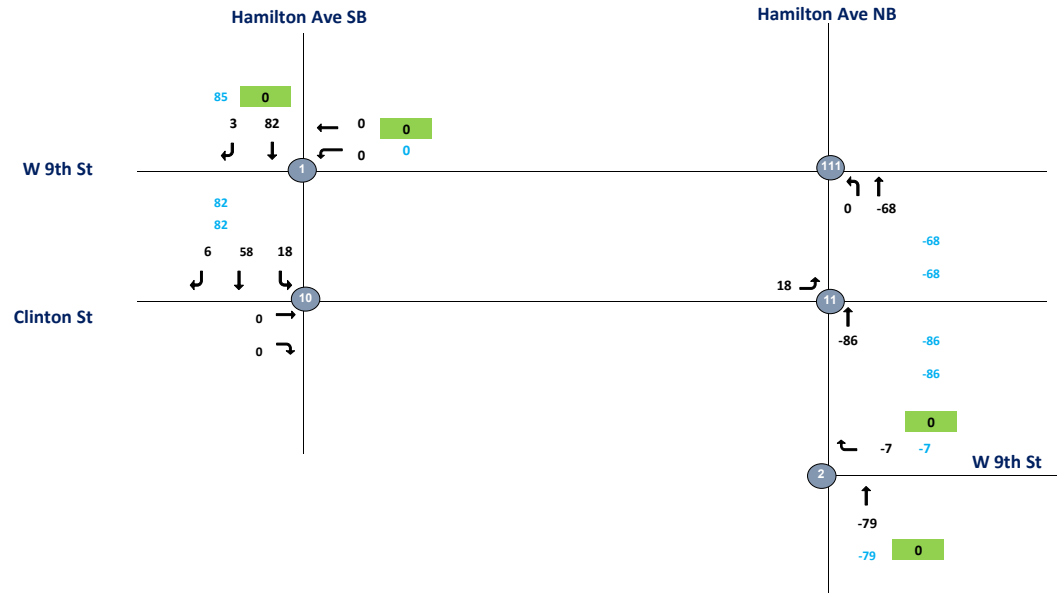

RH

4:00:00 PM

Intersection	Node	Approach	Balanced With-Action Increment					
			Inbound/Outbound					Total
			L2	L	T	R	R2	
Hamilton Ave SB & W 9th St 2019 (TMC-040)	1							
W 9th St	1	EB	0	0	0	0	0	
W 9th St	1	WB	0	0	0	0	0	
Hamilton Ave SB	1		0	0	0	0	0	
Hamilton Ave SB	1	SB	0	0	82	3	0	85
Hamilton Ave SB & W 9th St 2019 (TMC-040)	10							
Clinton Avenue	10	EB	0	0	0	0	0	
Clinton Avenue	10	WB	0	0	0	0	0	
Hamilton Ave SB	10		0	0	0	0	0	
Hamilton Ave SB	10	SB	0	18	58	6	0	82
Hamilton Ave SB & W 9th St 2019 (TMC-040)	11							
Clinton Avenue	11	EB	0	18	0	0	0	
Clinton Avenue	11		0	0	0	0	0	
Hamilton Ave	11	NB	0	0	-86	0	0	
Hamilton Ave	11		0	0	0	0	0	-68
Hamilton Ave SB & W 9th St 2019 (TMC-040)	111							
W 9th St	111	EB	0	0	0	0	0	
W 9th St	111	WB	0	0	0	0	0	
Hamilton Ave	111	NB	0	0	-68	0	0	
-	111	SB	0	0	0	0	0	-68
Hamilton Ave NB & W 9th St 2019 (TMC-041)	2							
W 9th St	2	EB	0	0	0	0	0	
W 9th St	2	WB	0	0	0	-7	0	
Hamilton Ave	2	NB	0	0	-79	0	0	
Hamilton Ave	2	SB	0	0	0	0	0	-86

CBD Tolling
Red Hook- Traffic Flowmap
LN Action Increment



- Legend:**
- 1 - Intersection (2019 Collected Data)
 - 7 - Intersection (Uncollected Data)
 - 100 - ATR Volume
 - 100 - Approach Volume

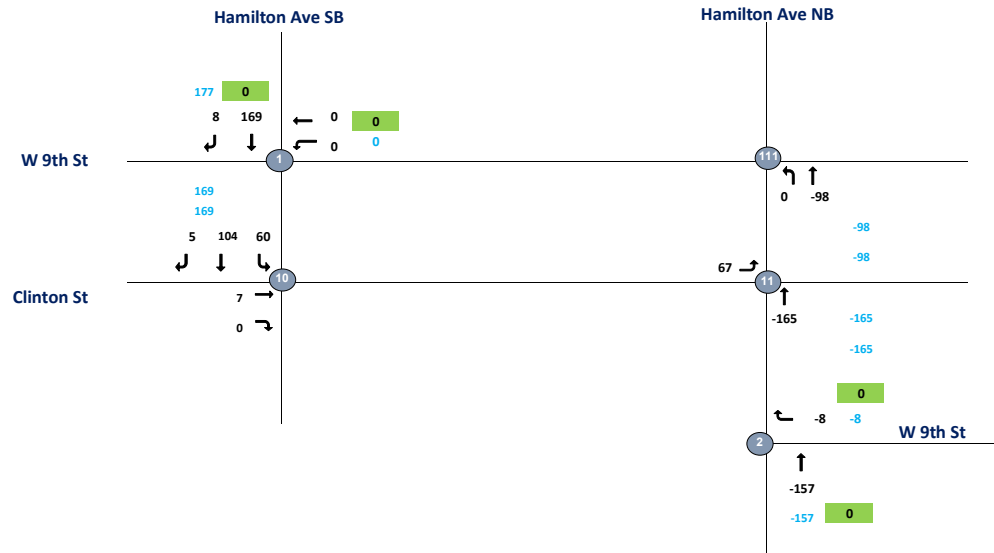

RH

9:00:00 PM

Intersection	Node	Approach	Balanced With-Action Increment						Total
			Inbound/Outbound						
			L2	L	T	R	R2		
Hamilton Ave SB & W 9th St 2019 (TMC-040)	1								
W 9th St	1	EB	0	0	0	0	0		
W 9th St	1	WB	0	0	0	0	0		
Hamilton Ave SB	1		0	0	0	0	0		
Hamilton Ave SB	1	SB	0	0	169	8	0	177	
Hamilton Ave SB & W 9th St 2019 (TMC-040)	10								
Clinton Avenue	10	EB	0	0	7	0	0		
Clinton Avenue	10	WB	0	0	0	0	0		
Hamilton Ave SB	10		0	0	0	0	0		
Hamilton Ave SB	10	SB	0	60	104	5	0	176	
Hamilton Ave SB & W 9th St 2019 (TMC-040)	11								
Clinton Avenue	11	EB	0	67	0	0	0		
Clinton Avenue	11		0	0	0	0	0		
Hamilton Ave	11	NB	0	0	-165	0	0		
Hamilton Ave	11		0	0	0	0	0	-98	
Hamilton Ave SB & W 9th St 2019 (TMC-040)	111								
W 9th St	111	EB	0	0	0	0	0		
W 9th St	111	WB	0	0	0	0	0		
Hamilton Ave	111	NB	0	0	-98	0	0		
-	111	SB	0	0	0	0	0	-98	
Hamilton Ave NB & W 9th St 2019 (TMC-041)	2								
W 9th St	2	EB	0	0	0	0	0		
W 9th St	2	WB	0	0	0	-8	0		
Hamilton Ave	2	NB	0	0	-157	0	0		
Hamilton Ave	2	SB	0	0	0	0	0	-165	

CBD Tolling
UE #1 - Traffic Flowmap
AM Action Increment



- Legend:**
- 1 - Intersection (2019 Collected Data)
 - 7 - Intersection (Uncollected Data)
 - 100 - ATR Volume
 - 100 - Approach Volume

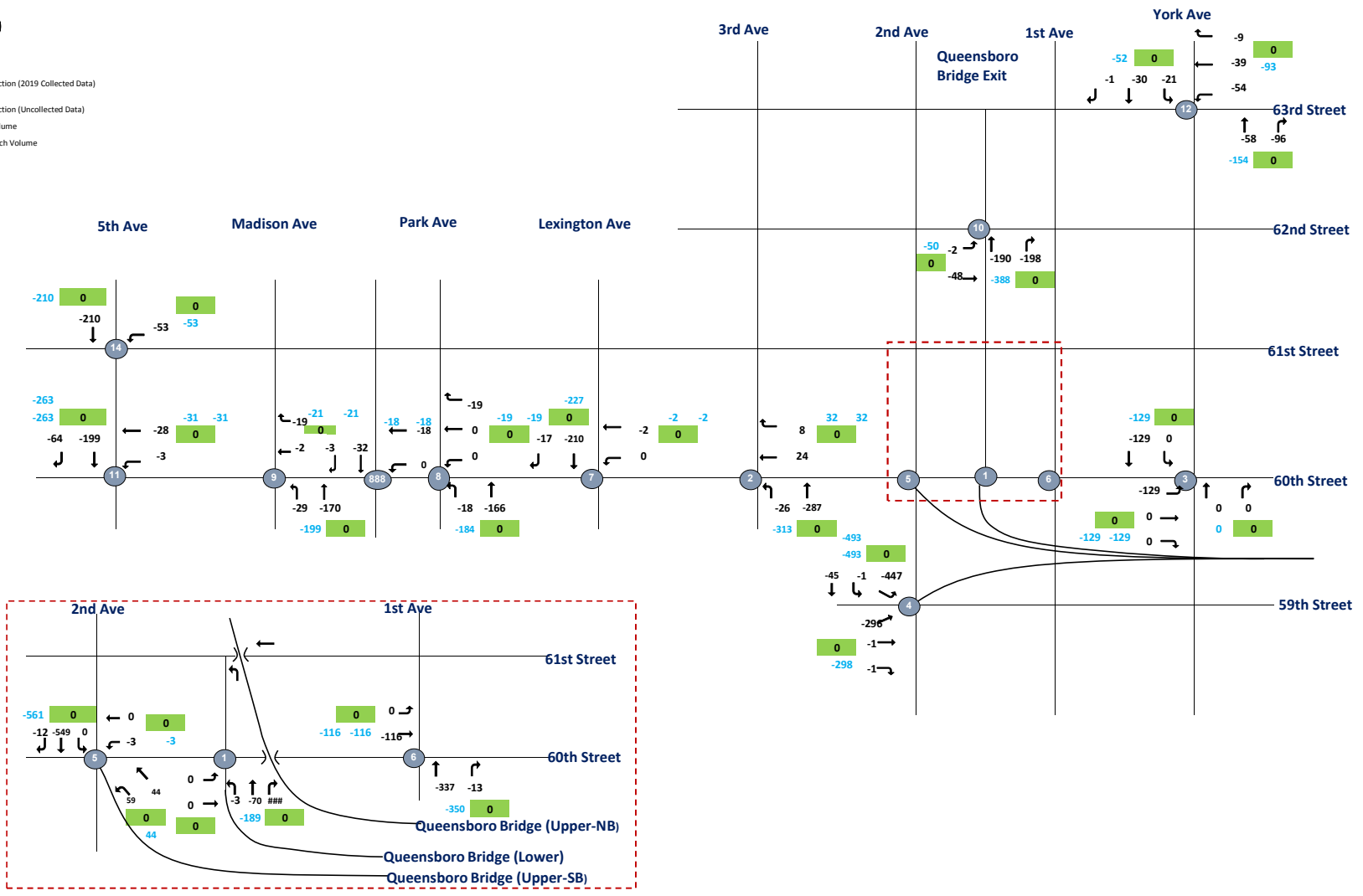

CBD Tolling
UE #2 - Traffic Flowmap
AM Action Increment



- Legend:**
- Intersection (2019 Collected Data)
 - Intersection (Uncollected Data)
 - 100 - ATR Volume
 - 100 - Approach Volume

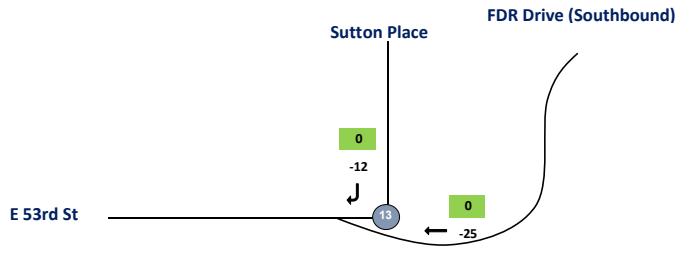

CBD Tolling
UE #3 - Traffic Flowmap
AM Action Increment



- Legend:**
- 1 - Intersection (2019 Collected Data)
 - 7 - Intersection (Uncollected Data)
 - 100 - ATR Volume
 - 100 - Approach Volume

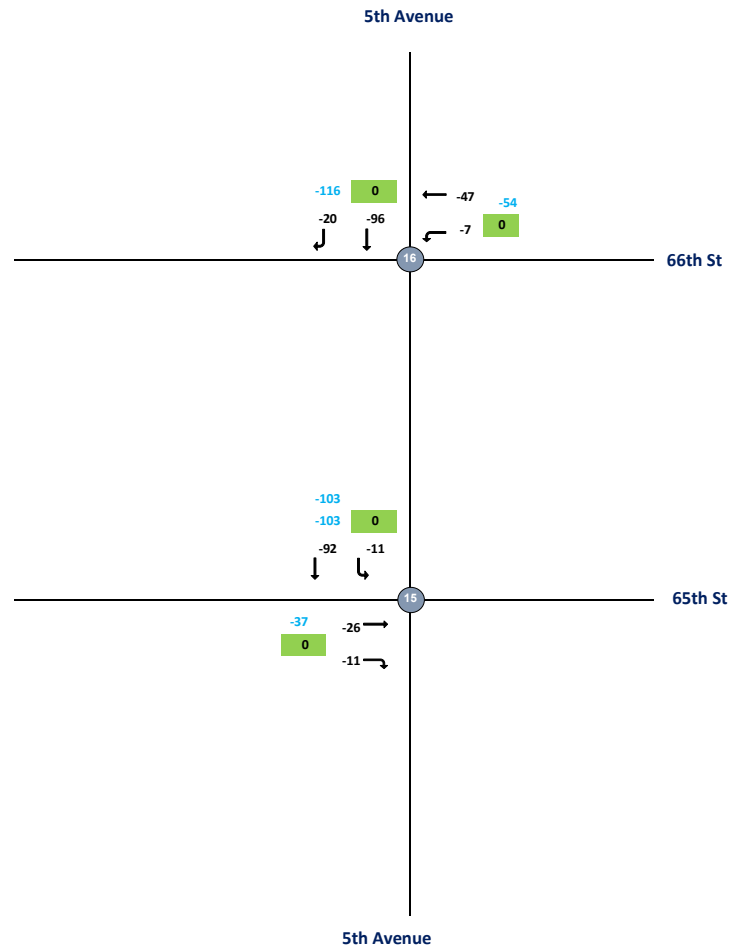

CBD Tolling
UE #3 - Traffic Flowmap
AM Action Increment



- Legend:**
- Intersection (2019 Collected Data)
 - Intersection (Uncollected Data)
 - 100 - ATR Volume
 - 100 - Approach Volume

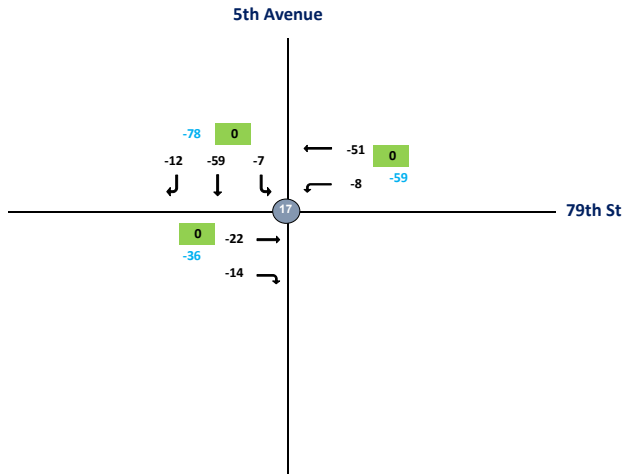

CBD Tolling
UE #4 - Traffic Flowmap
AM Action Increment



- Legend:**
- Intersection (2019 Collected Data)
 - Intersection (Uncollected Data)
 - 100 - ATR Volume
 - 100 - Approach Volume

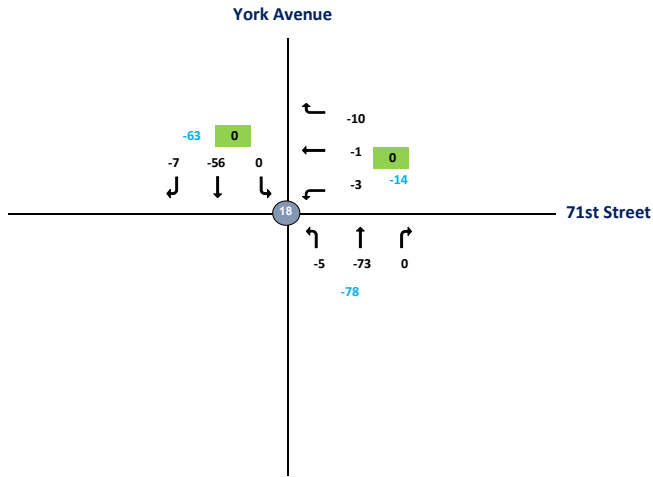

UE

8:00:00 AM

Intersection	Node	Approach	Total Vehicles						
			Inbound/Outbound						
			AM Peak Hour						
			L2	L	T	R	R2	Total	
60th Street & Queensboro Bridge Exit 2019 (TMC-022)	1								
60th Street	1	EB	0	0	0	0	0		
60th Street	1	WB	0	0	0	0	0		
Queensboro Bridge Exit	1	NB	0	-3	-70	-116	0		
	1	SB	0	0	0	0	0		-189
60th Street & 3rd Ave 2019 (TMC-023)	2								
60th Street	2	EB	0	0	0	0	0		
60th Street	2	WB	0	0	24	8	0		
3rd Ave	2	NB	0	-26	-287	0	0		
	2	SB	0	0	0	0	0		-281
60th St & York Ave 2019 (TMC-024)	3								
60th St	3	EB	0	-129	0	0	0		
60th St	3	WB	0	0	0	0	0		
York Ave	3	NB	0	0	0	0	0		
York Ave	3	SB	0	0	-129	0	0		-258
59th St & 2nd Ave 2019 (TMC-025)	4								
Queensboro Bridge Exit (SWB)	4								
59th St	4	EB	0	0	-296	-1	-1		
	4	WB	0	0	0	0	0		
	4	NB	0	0	0	0	0		
2nd Ave	4	SB	-447	-1	-45	0	0		-791
60th Street & 2nd Ave 2019 (TMC-026)	5	WB(bridge)							
Queensboro Bridge Exit (NWB)	5	NW	59	44	0	0	0		
60th St	5	EB	0	0	0	0	0		
60th St	5	WB	0	-3	0	0	0		
	5	NB	0	0	0	0	0		
2nd Ave	5	SB	0	0	-549	-12	0		-564
60th St & 1st Ave 2019 (TMC-027)	6								
60th Ave	6	EB	0	0	-116	0	0		
	6	WB	0	0	0	0	0		
1st Ave	6	NB	0	0	-337	-13	0		
	6	SB	0	0	0	0	0		-466

60th St & Lexington Ave 2019 (TMC-028)	7							
	7	EB	0	0	0	0	0	
60th St	7	WB	0	0	-2	0	0	
	7	NB	0	0	0	0	0	
Lexington Ave	7	SB	0	0	-210	-17	0	-229
60th St & Park Ave 2019 (TMC-029)	8							
	8	EB	0	0	0	0	0	
60th St	8	WB	0	0	0	-19	0	
Park Ave	8	NB	0	-18	-166	0	0	
Park Ave	8	SB	0	0	0	0	0	-203
60th St & Park Ave 2019 (TMC-029)	888							
	888	EB	0	0	0	0	0	
60th St	888	WB	0	0	-18	0	0	
Park Ave	888	NB	0	0	0	0	0	
Park Ave	888	SB	0	0	-32	-3	0	-53
60th St & Madison Ave 2019 (TMC-030)	9							
	9	EB	0	0	0	0	0	
60th St	9	WB	0	0	-2	-19	0	
Madison Ave	9	NB	0	-29	-170	0	0	
	9	SB	0	0	0	0	0	-220
62nd St & Queensboror Bridge Exit 2019 (TMC-031)	10							
62nd St	10	EB	0	-2	-48	0	0	
	10	WB	0	0	0	0	0	
Queensboro Bridge Exit	10	NB	0	0	-190	-198	0	
	10	SB	0	0	0	0	0	-438
60th St & 5th Ave 2019 (TMC-032)	11							
	11	EB	0	0	0	0	0	
60th St	11	WB	0	-3	-28	0	0	
	11	NB	0	0	0	0	0	
5th Ave	11	SB	0	0	-199	-64	0	-294

63rd St & York Ave 2019 (TMC-033)	12							
	12	EB	0	0	0	0	0	
63rd St	12	WB	0	-54	-39	-9	0	
York Ave	12	NB	0	0	-58	-96	0	
York Ave	12	SB	0	-21	-30	-1	0	-308
53rd St & FDR Drive 2019 (TMC-034)	13							
	13	EB	0	0	0	0	0	
53rd St	13	SW	0	0	0	-25	0	
	13	NB	0	0	0	0	0	
FDR Drive	13	SB	0	0	0	-12	0	-37
61st St & 5th Ave 2019 (TMC-035)	14							
	14	EB	0	0	0	0	0	
61st St	14	WB	0	-53	0	0	0	
	14	NB	0	0	0	0	0	
5th Ave	14	SB	0	0	-210	0	0	-263
65th St & 5th Ave 2019 (TMC-036)	15							
65th St	15	EB	0	0	-26	-11	0	
	15	WB	0	0	0	0	0	
	15	NB	0	0	0	0	0	
5th Ave	15	SB	0	-11	-92	0	0	-140
66th St & 5th Ave 2019 (TMC-037)	16							
	16	EB	0	0	0	0	0	
66th St	16	WB	0	-7	-47	0	0	
	16	NB	0	0	0	0	0	
5th Ave	16	SB	0	0	-96	-20	0	-170
79th St & 5th Ave 2019 (TMC-038)	17							
79th St	17	EB	0	0	-22	-14	0	
79th St	17	WB	0	-8	-51	0	0	
	17	NB	0	0	0	0	0	
5th Ave	17	SB	0	-7	-59	-12	0	-173
71st St & York Ave 2019 (TMC-039)	18							
	18	EB	0	0	0	0	0	
71st St	18	WB	0	-3	-1	-10	0	
York Ave	18	NB	0	-5	-73	0	0	
York Ave	18	SB	0	0	-56	-7	0	-155

CBD Tolling
UE #1 - Traffic Flowmap
MD Action Increment



- Legend:**
- 1 - Intersection (2019 Collected Data)
 - 7 - Intersection (Uncollected Data)
 - 100 - ATR Volume
 - 100 - Approach Volume

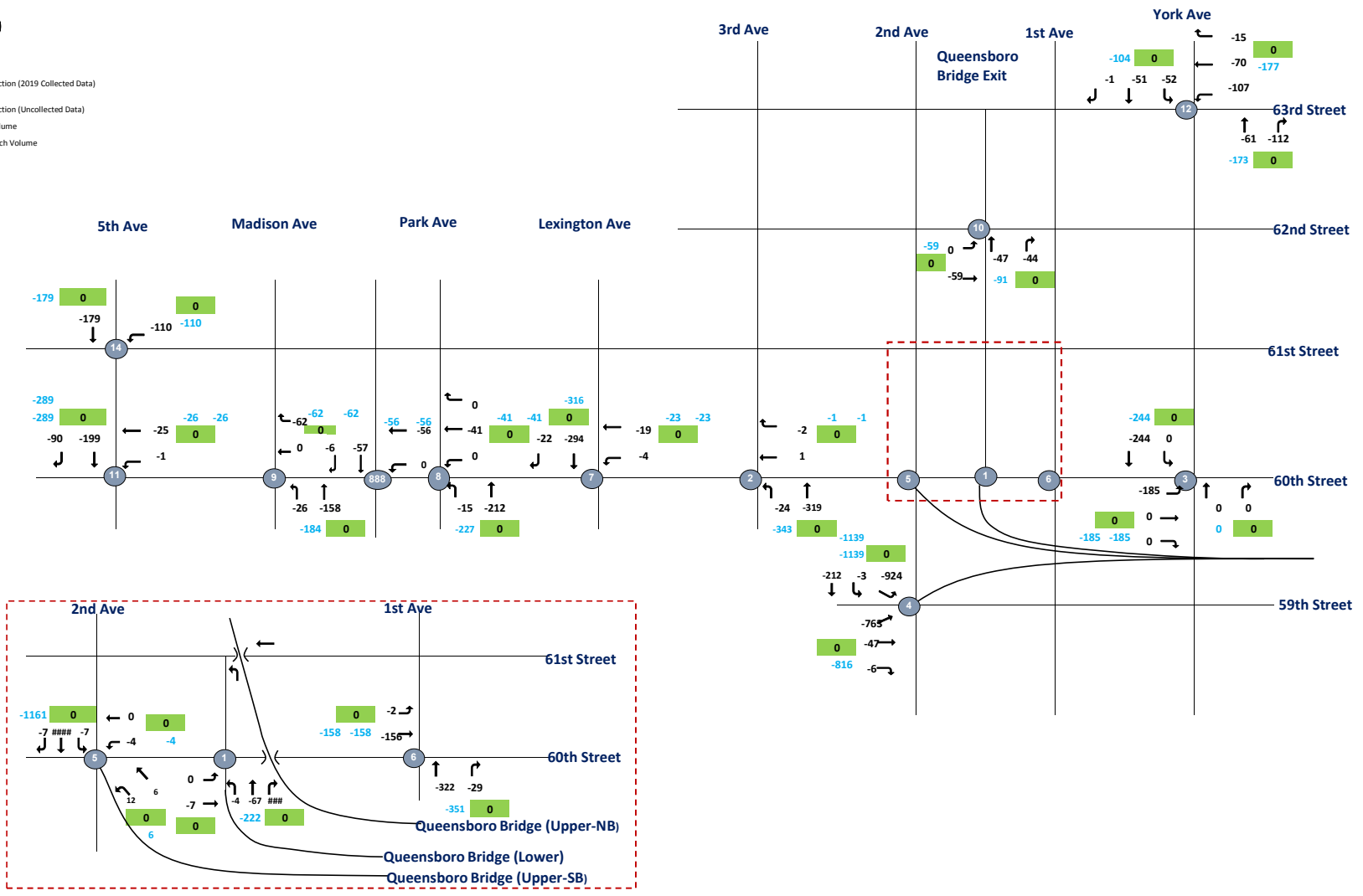

CBD Tolling
UE #2 - Traffic Flowmap
MD Action Increment



- Legend:**
- Intersection (2019 Collected Data)
 - Intersection (Uncollected Data)
 - 100 - ATR Volume
 - 100 - Approach Volume

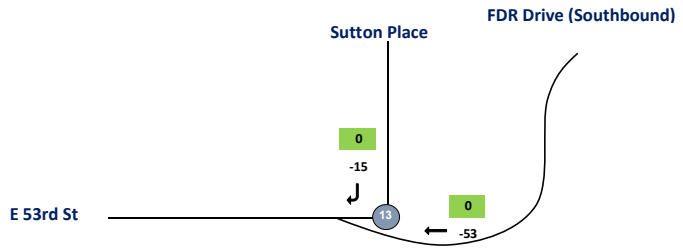

CBD Tolling
UE #3 - Traffic Flowmap
MD Action Increment



- Legend:**
- 1 - Intersection (2019 Collected Data)
 - 7 - Intersection (Uncollected Data)
 - 100 - ATR Volume
 - 100 - Approach Volume

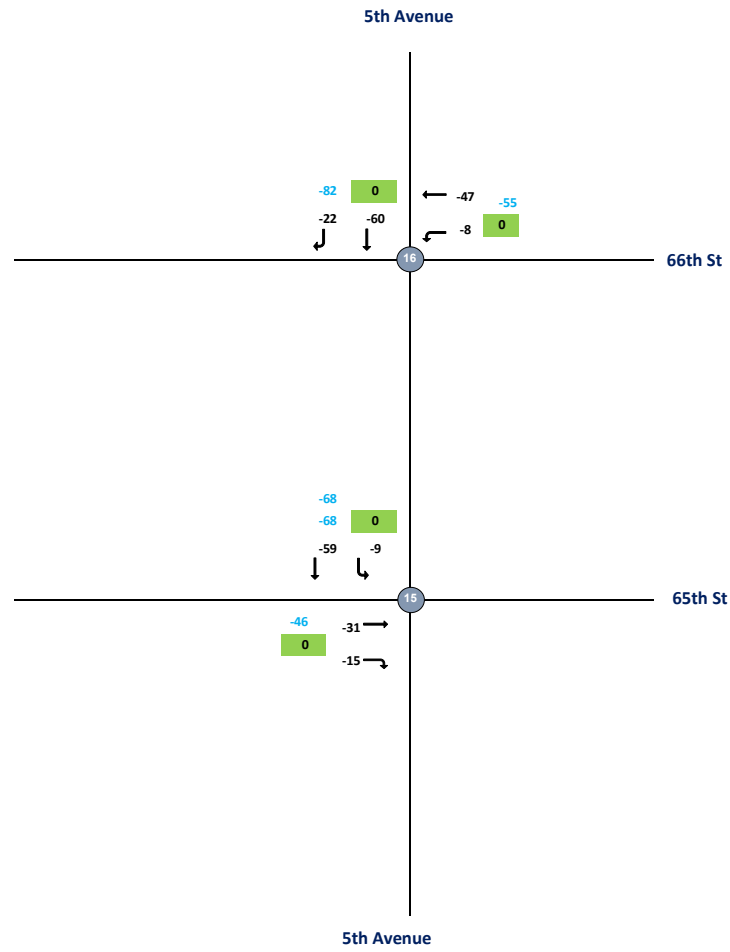

CBD Tolling
UE #3 - Traffic Flowmap
MD Action Increment



- Legend:**
- Intersection (2019 Collected Data)
 - Intersection (Uncollected Data)
 - 100 - ATR Volume
 - 100 - Approach Volume

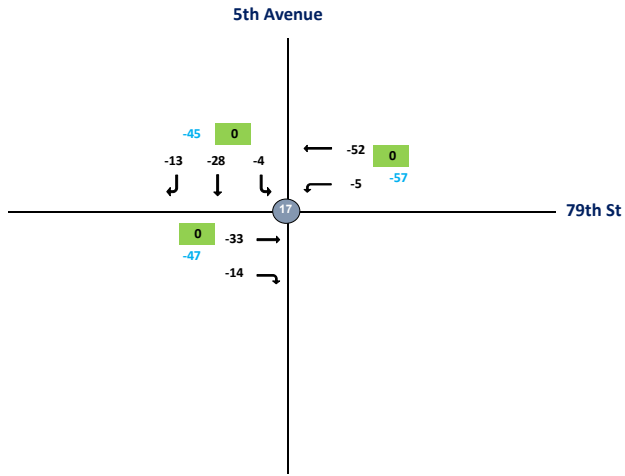

CBD Tolling
UE #4 - Traffic Flowmap
MD Action Increment



- Legend:**
- Intersection (2019 Collected Data)
 - Intersection (Uncollected Data)
 - 100 - ATR Volume
 - 100 - Approach Volume

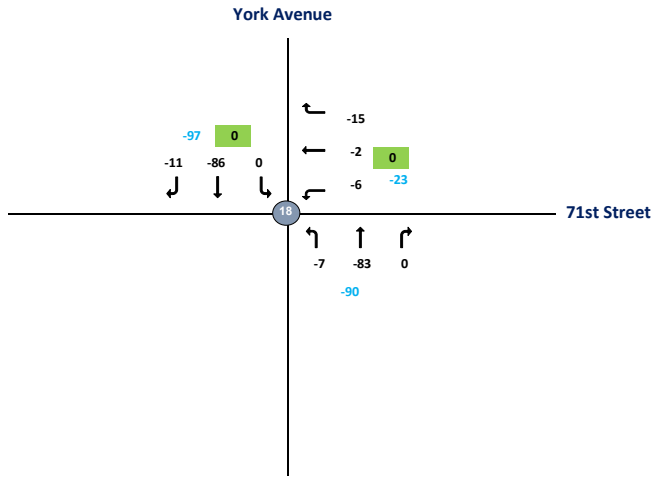

UE

1:00:00 PM

Intersection	Node	Approach	Total Vehicles						
			Inbound/Outbound						
			MD Peak Hour						
			L2	L	T	R	R2	Total	
60th Street & Queensboro Bridge Exit 2019 (TMC-022)	1								
60th Street	1	EB	0	0	-7	0	0		
60th Street	1	WB	0	0	0	0	0		
Queensboro Bridge Exit	1	NB	0	-4	-67	-151	0		
	1	SB	0	0	0	0	0		-229
60th Street & 3rd Ave 2019 (TMC-023)	2								
60th Street	2	EB	0	0	0	0	0		
60th Street	2	WB	0	0	1	-2	0		
3rd Ave	2	NB	0	-24	-319	0	0		
	2	SB	0	0	0	0	0		-344
60th St & York Ave 2019 (TMC-024)	3								
60th St	3	EB	0	-185	0	0	0		
60th St	3	WB	0	0	0	0	0		
York Ave	3	NB	0	0	0	0	0		
York Ave	3	SB	0	0	-244	0	0		-429
59th St & 2nd Ave 2019 (TMC-025)	4								
Queensboro Bridge Exit (SWB)	4								
59th St	4	EB	0	0	-763	-47	-6		
	4	WB	0	0	0	0	0		
	4	NB	0	0	0	0	0		
2nd Ave	4	SB	-924	-3	-212	0	0		-1955
60th Street & 2nd Ave 2019 (TMC-026)	5	WB(bridge)							
Queensboro Bridge Exit (NWB)	5	NW	12	6	0	0	0		
60th St	5	EB	0	0	0	0	0		
60th St	5	WB	0	-4	0	0	0		
	5	NB	0	0	0	0	0		
2nd Ave	5	SB	-7	0	-1147	-7	0		-1165
60th St & 1st Ave 2019 (TMC-027)	6								
60th Ave	6	EB	0	-2	-156	0	0		
	6	WB	0	0	0	0	0		
1st Ave	6	NB	0	0	-322	-29	0		
	6	SB	0	0	0	0	0		-509

60th St & Lexington Ave 2019 (TMC-028)	7							
	7	EB	0	0	0	0	0	
60th St	7	WB	0	-4	-19	0	0	
	7	NB	0	0	0	0	0	
Lexington Ave	7	SB	0	0	-294	-22	0	-339
60th St & Park Ave 2019 (TMC-029)	8							
	8	EB	0	0	0	0	0	
60th St	8	WB	0	0	-41	0	0	
Park Ave	8	NB	0	-15	-212	0	0	
Park Ave	8	SB	0	0	0	0	0	-268
60th St & Park Ave 2019 (TMC-029)	888							
	888	EB	0	0	0	0	0	
60th St	888	WB	0	0	-56	0	0	
Park Ave	888	NB	0	0	0	0	0	
Park Ave	888	SB	0	0	-57	-6	0	-119
60th St & Madison Ave 2019 (TMC-030)	9							
	9	EB	0	0	0	0	0	
60th St	9	WB	0	0	0	-62	0	
Madison Ave	9	NB	0	-26	-158	0	0	
	9	SB	0	0	0	0	0	-246
62nd St & Queensboror Bridge Exit 2019 (TMC-031)	10							
62nd St	10	EB	0	0	-59	0	0	
	10	WB	0	0	0	0	0	
Queensboro Bridge Exit	10	NB	0	0	-47	-44	0	
	10	SB	0	0	0	0	0	-150
60th St & 5th Ave 2019 (TMC-032)	11							
	11	EB	0	0	0	0	0	
60th St	11	WB	0	-1	-25	0	0	
	11	NB	0	0	0	0	0	
5th Ave	11	SB	0	0	-199	-90	0	-315

63rd St & York Ave 2019 (TMC-033)	12								
	12	EB	0	0	0	0	0		
63rd St	12	WB	0	-107	-70	-15	0		
York Ave	12	NB	0	0	-61	-112	0		
York Ave	12	SB	0	-52	-51	-1	0		-469
53rd St & FDR Drive 2019 (TMC-034)	13								
	13	EB	0	0	0	0	0		
53rd St	13	SW	0	0	0	-53	0		
	13	NB	0	0	0	0	0		
FDR Drive	13	SB	0	0	0	-15	0		-68
61st St & 5th Ave 2019 (TMC-035)	14								
	14	EB	0	0	0	0	0		
61st St	14	WB	0	-110	0	0	0		
	14	NB	0	0	0	0	0		
5th Ave	14	SB	0	0	-179	0	0		-289
65th St & 5th Ave 2019 (TMC-036)	15								
65th St	15	EB	0	0	-31	-15	0		
	15	WB	0	0	0	0	0		
	15	NB	0	0	0	0	0		
5th Ave	15	SB	0	-9	-59	0	0		-114
66th St & 5th Ave 2019 (TMC-037)	16								
	16	EB	0	0	0	0	0		
66th St	16	WB	0	-8	-47	0	0		
	16	NB	0	0	0	0	0		
5th Ave	16	SB	0	0	-60	-22	0		-137
79th St & 5th Ave 2019 (TMC-038)	17								
79th St	17	EB	0	0	-33	-14	0		
79th St	17	WB	0	-5	-52	0	0		
	17	NB	0	0	0	0	0		
5th Ave	17	SB	0	-4	-28	-13	0		-149
71st St & York Ave 2019 (TMC-039)	18								
	18	EB	0	0	0	0	0		
71st St	18	WB	0	-6	-2	-15	0		
York Ave	18	NB	0	-7	-83	0	0		
York Ave	18	SB	0	0	-86	-11	0		-210

CBD Tolling
UE #1 - Traffic Flowmap
PM Action Increment



- Legend:**
- 1 - Intersection (2019 Collected Data)
 - 7 - Intersection (Uncollected Data)
 - 100 - ATR Volume
 - 100 - Approach Volume

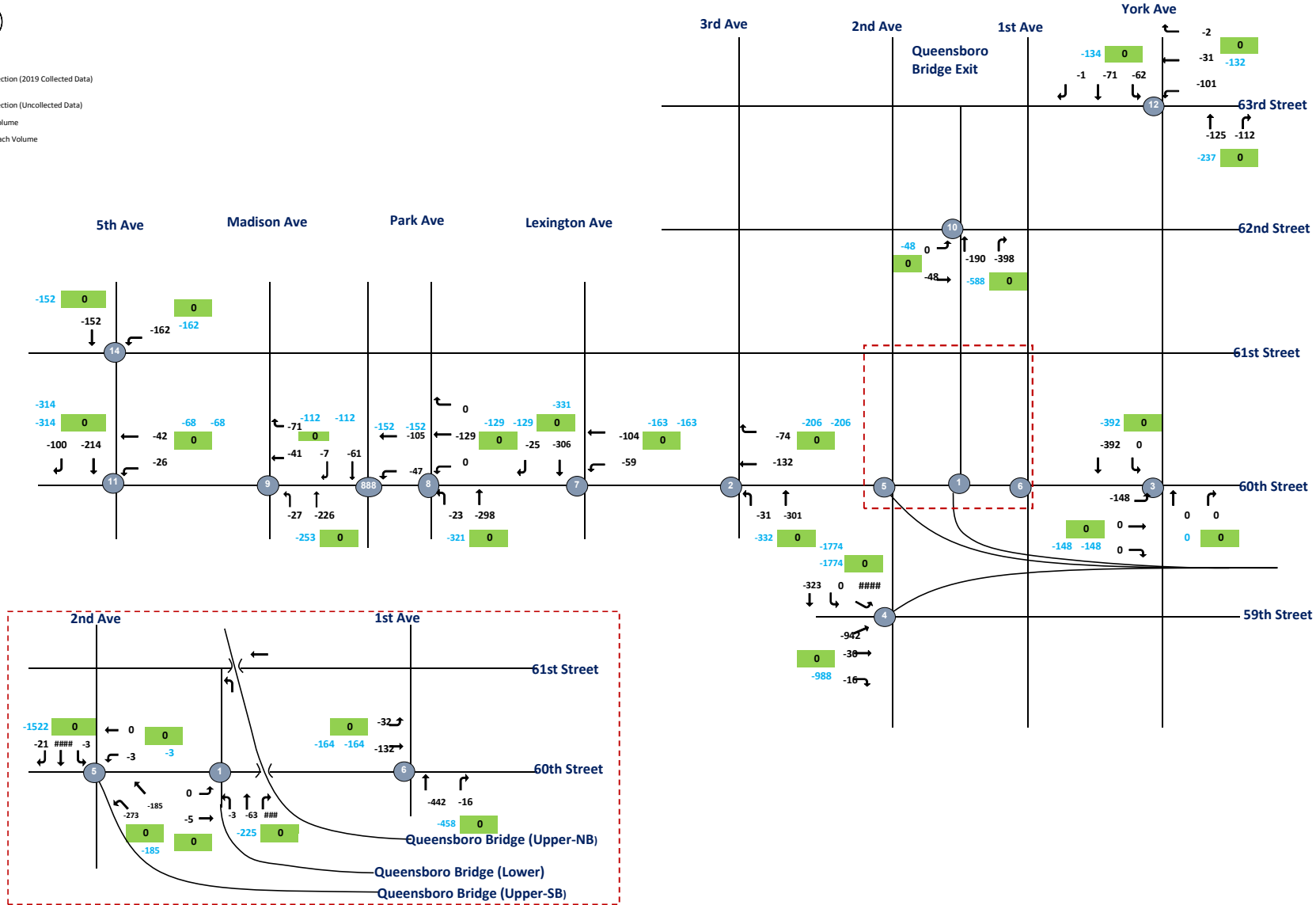

CBD Tolling
UE #2 - Traffic Flowmap
PM Action Increment



- Legend:**
- Intersection (2019 Collected Data)
 - Intersection (Uncollected Data)
 - 100 - ATR Volume
 - 100 - Approach Volume

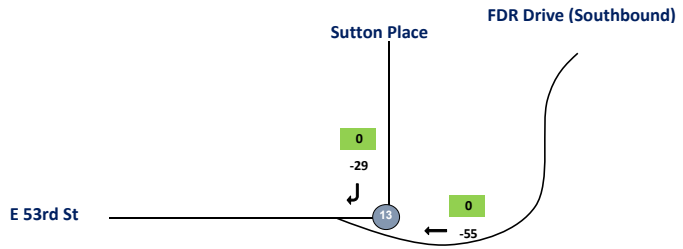

CBD Tolling
UE #3 - Traffic Flowmap
PM Action Increment



- Legend:**
- 1 - Intersection (2019 Collected Data)
 - 7 - Intersection (Uncollected Data)
 - 100 - ATR Volume
 - 100 - Approach Volume

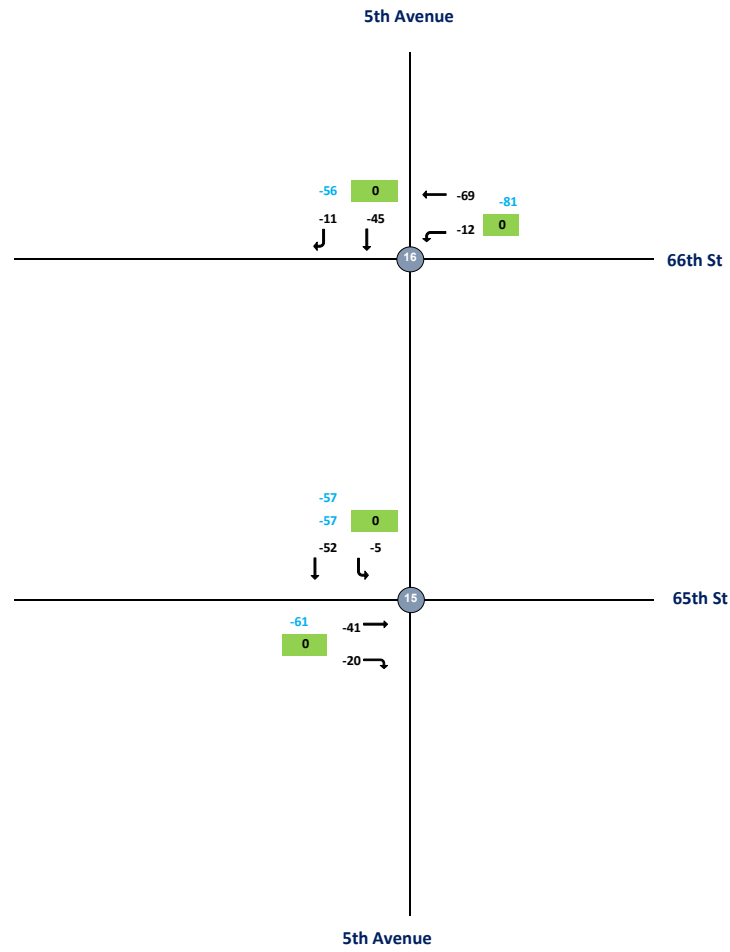

CBD Tolling
UE #3 - Traffic Flowmap
PM Action Increment



- Legend:**
- Intersection (2019 Collected Data)
 - Intersection (Uncollected Data)
 - 100 - ATR Volume
 - 100 - Approach Volume

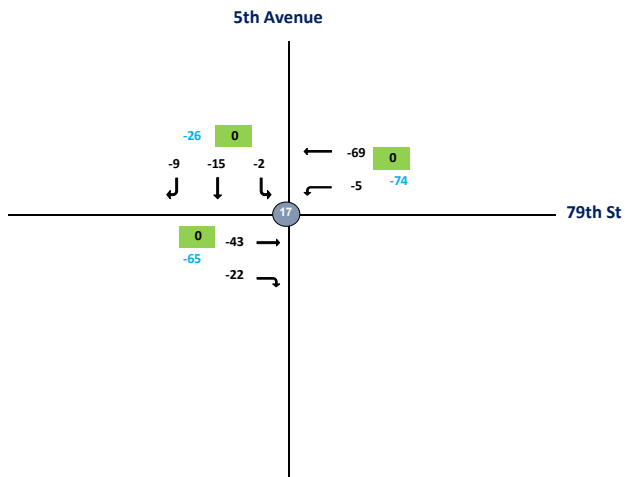

CBD Tolling
UE #4 - Traffic Flowmap
PM Action Increment



- Legend:**
- Intersection (2019 Collected Data)
 - Intersection (Uncollected Data)
 - 100 - ATR Volume
 - 100 - Approach Volume

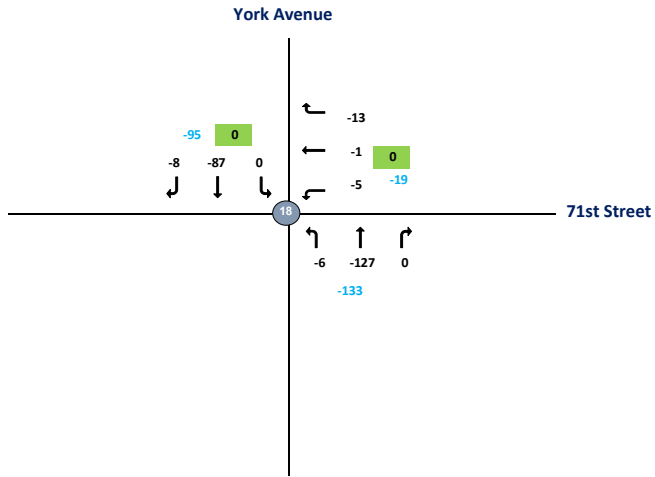

UE

5:00:00 PM

Intersection	Node	Approach	Total Vehicles						
			Inbound/Outbound						
			PM Peak Hour						
			L2	L	T	R	R2	Total	
60th Street & Queensboro Bridge Exit 2019 (TMC-022)	1								
60th Street	1	EB	0	0	-5	0	0		
60th Street	1	WB	0	0	0	0	0		
Queensboro Bridge Exit	1	NB	0	-3	-63	-159	0		
	1	SB	0	0	0	0	0		-230
60th Street & 3rd Ave 2019 (TMC-023)	2								
60th Street	2	EB	0	0	0	0	0		
60th Street	2	WB	0	0	-132	-74	0		
3rd Ave	2	NB	0	-31	-301	0	0		
	2	SB	0	0	0	0	0		-538
60th St & York Ave 2019 (TMC-024)	3								
60th St	3	EB	0	-148	0	0	0		
60th St	3	WB	0	0	0	0	0		
York Ave	3	NB	0	0	0	0	0		
York Ave	3	SB	0	0	-392	0	0		-540
59th St & 2nd Ave 2019 (TMC-025)	4								
Queensboro Bridge Exit (SWB)	4								
59th St	4	EB	0	0	-942	-30	-16		
	4	WB	0	0	0	0	0		
	4	NB	0	0	0	0	0		
2nd Ave	4	SB	-1451	0	-323	0	0		-2762
60th Street & 2nd Ave 2019 (TMC-026)	5	WB(bridge)							
Queensboro Bridge Exit (NWB)	5	NW	-273	-185	0	0	0		
60th St	5	EB	0	0	0	0	0		
60th St	5	WB	0	-3	0	0	0		
	5	NB	0	0	0	0	0		
2nd Ave	5	SB	-3	0	-1498	-21	0		-1525
60th St & 1st Ave 2019 (TMC-027)	6								
60th Ave	6	EB	0	-32	-132	0	0		
	6	WB	0	0	0	0	0		
1st Ave	6	NB	0	0	-442	-16	0		
	6	SB	0	0	0	0	0		-622

60th St & Lexington Ave 2019 (TMC-028)	7							
	7	EB	0	0	0	0	0	
60th St	7	WB	0	-59	-104	0	0	
	7	NB	0	0	0	0	0	
Lexington Ave	7	SB	0	0	-306	-25	0	-494
60th St & Park Ave 2019 (TMC-029)	8							
	8	EB	0	0	0	0	0	
60th St	8	WB	0	0	-129	0	0	
Park Ave	8	NB	0	-23	-298	0	0	
Park Ave	8	SB	0	0	0	0	0	-450
60th St & Park Ave 2019 (TMC-029)	888							
	888	EB	0	0	0	0	0	
60th St	888	WB	0	-47	-105	0	0	
Park Ave	888	NB	0	0	0	0	0	
Park Ave	888	SB	0	0	-61	-7	0	-220
60th St & Madison Ave 2019 (TMC-030)	9							
	9	EB	0	0	0	0	0	
60th St	9	WB	0	0	-41	-71	0	
Madison Ave	9	NB	0	-27	-226	0	0	
	9	SB	0	0	0	0	0	-365
62nd St & Queensboror Bridge Exit 2019 (TMC-031)	10							
62nd St	10	EB	0	0	-48	0	0	
	10	WB	0	0	0	0	0	
Queensboro Bridge Exit	10	NB	0	0	-190	-398	0	
	10	SB	0	0	0	0	0	-636
60th St & 5th Ave 2019 (TMC-032)	11							
	11	EB	0	0	0	0	0	
60th St	11	WB	0	-26	-42	0	0	
	11	NB	0	0	0	0	0	
5th Ave	11	SB	0	0	-214	-100	0	-382

63rd St & York Ave 2019 (TMC-033)	12							
	12	EB	0	0	0	0	0	
63rd St	12	WB	0	-101	-31	-2	0	
York Ave	12	NB	0	0	-125	-112	0	
York Ave	12	SB	0	-62	-71	-1	0	-505
53rd St & FDR Drive 2019 (TMC-034)	13							
	13	EB	0	0	0	0	0	
53rd St	13	SW	0	0	0	-55	0	
	13	NB	0	0	0	0	0	
FDR Drive	13	SB	0	0	0	-29	0	-84
61st St & 5th Ave 2019 (TMC-035)	14							
	14	EB	0	0	0	0	0	
61st St	14	WB	0	-162	0	0	0	
	14	NB	0	0	0	0	0	
5th Ave	14	SB	0	0	-152	0	0	-314
65th St & 5th Ave 2019 (TMC-036)	15							
65th St	15	EB	0	0	-41	-20	0	
	15	WB	0	0	0	0	0	
	15	NB	0	0	0	0	0	
5th Ave	15	SB	0	-5	-52	0	0	-118
66th St & 5th Ave 2019 (TMC-037)	16							
	16	EB	0	0	0	0	0	
66th St	16	WB	0	-12	-69	0	0	
	16	NB	0	0	0	0	0	
5th Ave	16	SB	0	0	-45	-11	0	-137
79th St & 5th Ave 2019 (TMC-038)	17							
79th St	17	EB	0	0	-43	-22	0	
79th St	17	WB	0	-5	-69	0	0	
	17	NB	0	0	0	0	0	
5th Ave	17	SB	0	-2	-15	-9	0	-165
71st St & York Ave 2019 (TMC-039)	18							
	18	EB	0	0	0	0	0	
71st St	18	WB	0	-5	-1	-13	0	
York Ave	18	NB	0	-6	-127	0	0	
York Ave	18	SB	0	0	-87	-8	0	-247

CBD Tolling
UE #1 - Traffic Flowmap
LN Action Increment



- Legend:**
- 1 - Intersection (2019 Collected Data)
 - 7 - Intersection (Uncollected Data)
 - 100 - ATR Volume
 - 100 - Approach Volume

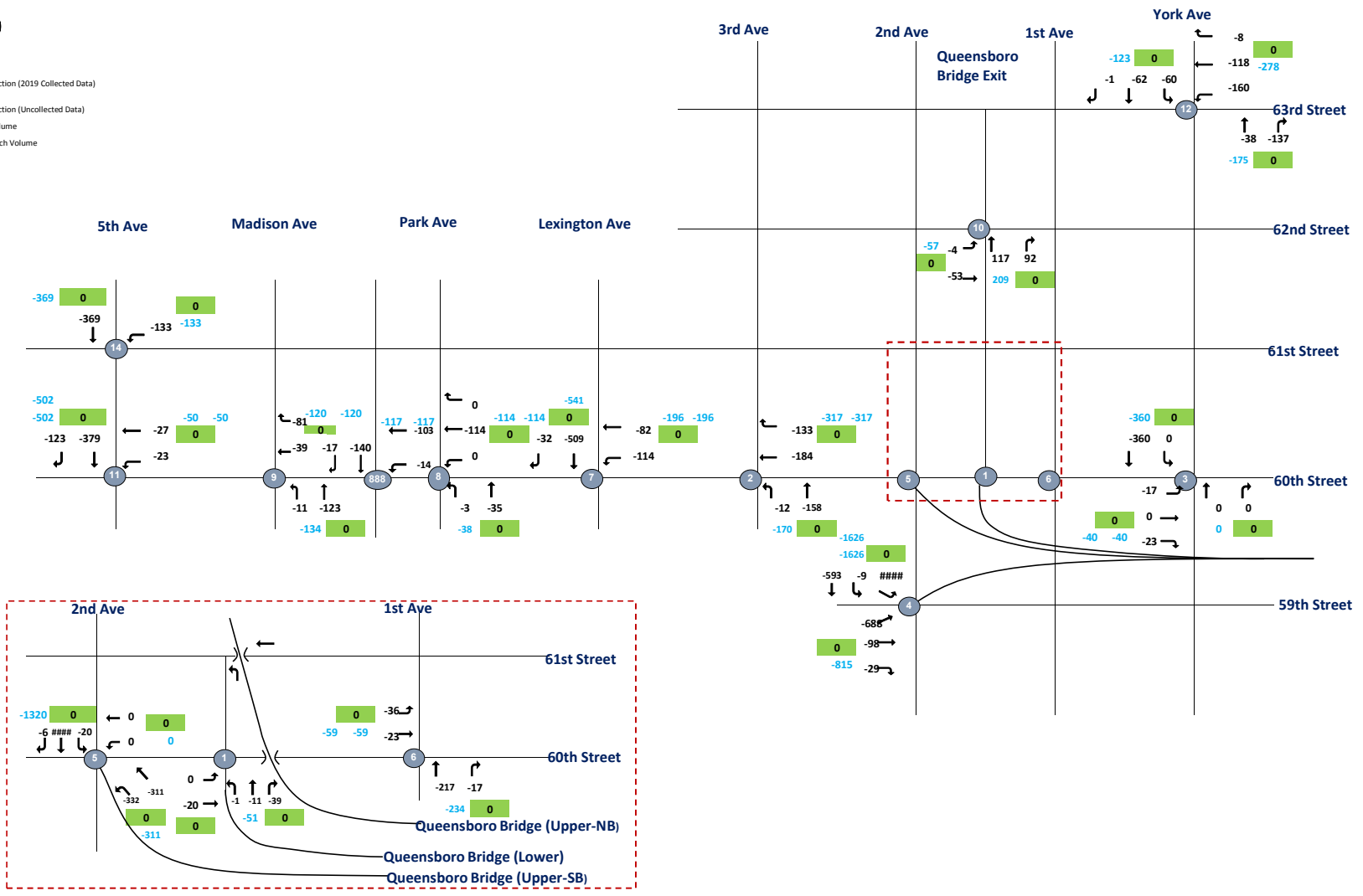

CBD Tolling
UE #2 - Traffic Flowmap
LN Action Increment



- Legend:**
- Intersection (2019 Collected Data)
 - Intersection (Uncollected Data)
 - 100 - ATR Volume
 - 100 - Approach Volume

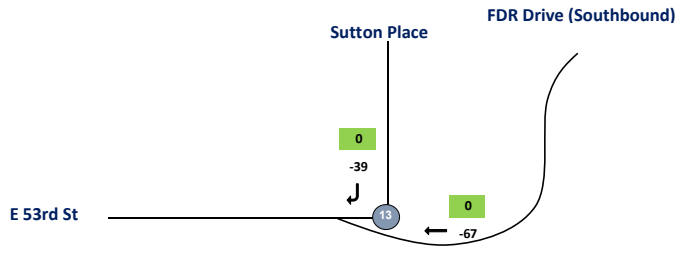

CBD Tolling
UE #3 - Traffic Flowmap
LN Action Increment



- Legend:**
- 1 - Intersection (2019 Collected Data)
 - 7 - Intersection (Uncollected Data)
 - 100 - ATR Volume
 - 100 - Approach Volume

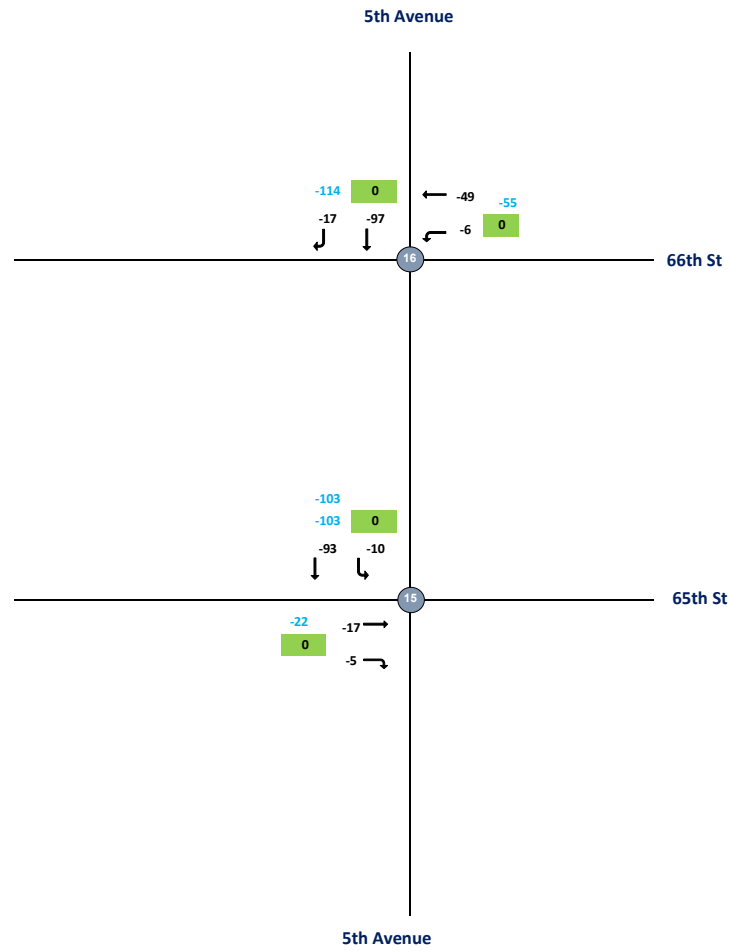

CBD Tolling
UE #3 - Traffic Flowmap
LN Action Increment



- Legend:**
- Intersection (2019 Collected Data)
 - Intersection (Uncollected Data)
 - 100 - ATR Volume
 - 100 - Approach Volume

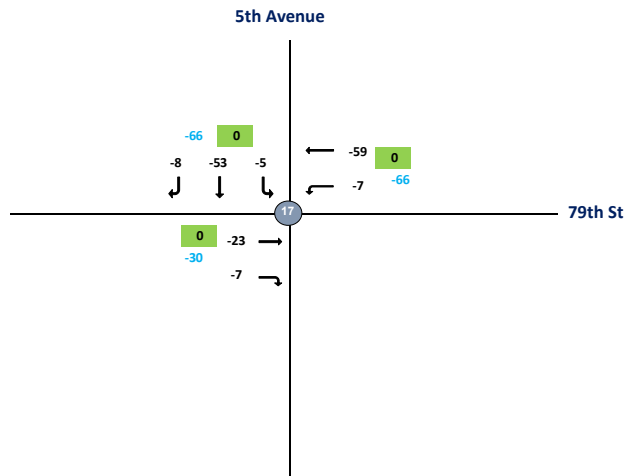

CBD Tolling
UE #4 - Traffic Flowmap
LN Action Increment



- Legend:**
- Intersection (2019 Collected Data)
 - Intersection (Uncollected Data)
 - 100 - ATR Volume
 - 100 - Approach Volume

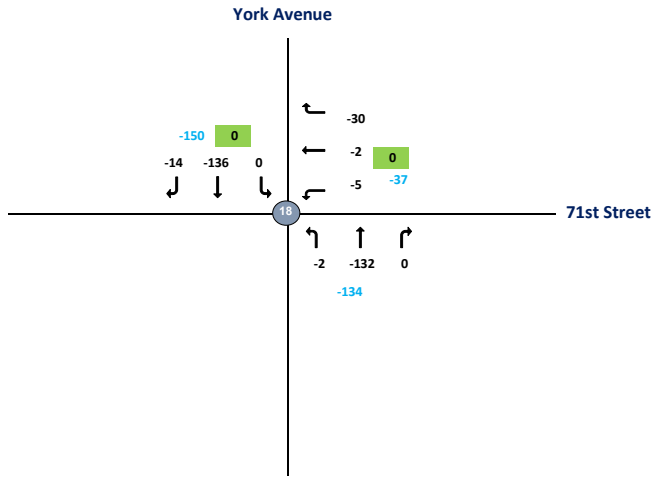

UE

9:00:00 PM

Intersection	Node	Approach	Total Vehicles						
			Inbound/Outbound						
			LN Peak Hour						
			L2	L	T	R	R2	Total	
60th Street & Queensboro Bridge Exit 2019 (TMC-022)	1								
60th Street	1	EB	0	0	-20	0	0		
60th Street	1	WB	0	0	0	0	0		
Queensboro Bridge Exit	1	NB	0	-1	-11	-39	0		
	1	SB	0	0	0	0	0		-71
60th Street & 3rd Ave 2019 (TMC-023)	2								
60th Street	2	EB	0	0	0	0	0		
60th Street	2	WB	0	0	-184	-133	0		
3rd Ave	2	NB	0	-12	-158	0	0		
	2	SB	0	0	0	0	0		-487
60th St & York Ave 2019 (TMC-024)	3								
60th St	3	EB	0	-17	0	-23	0		
60th St	3	WB	0	0	0	0	0		
York Ave	3	NB	0	0	0	0	0		
York Ave	3	SB	0	0	-360	0	0		-400
59th St & 2nd Ave 2019 (TMC-025)	4								
Queensboro Bridge Exit (SWB)	4								
59th St	4	EB	0	0	-688	-98	-29		
	4	WB	0	0	0	0	0		
	4	NB	0	0	0	0	0		
2nd Ave	4	SB	-1024	-9	-593	0	0		-2441
60th Street & 2nd Ave 2019 (TMC-026)	5	WB(bridge)							
Queensboro Bridge Exit (NWB)	5	NW	-332	-311	0	0	0		
60th St	5	EB	0	0	0	0	0		
60th St	5	WB	0	0	0	0	0		
	5	NB	0	0	0	0	0		
2nd Ave	5	SB	-20	0	-1294	-6	0		-1320
60th St & 1st Ave 2019 (TMC-027)	6								
60th Ave	6	EB	0	-36	-23	0	0		
	6	WB	0	0	0	0	0		
1st Ave	6	NB	0	0	-217	-17	0		
	6	SB	0	0	0	0	0		-293

60th St & Lexington Ave 2019 (TMC-028)	7							
	7	EB	0	0	0	0	0	
60th St	7	WB	0	-114	-82	0	0	
	7	NB	0	0	0	0	0	
Lexington Ave	7	SB	0	0	-509	-32	0	-737
60th St & Park Ave 2019 (TMC-029)	8							
	8	EB	0	0	0	0	0	
60th St	8	WB	0	0	-114	0	0	
Park Ave	8	NB	0	-3	-35	0	0	
Park Ave	8	SB	0	0	0	0	0	-152
60th St & Park Ave 2019 (TMC-029)	888							
	888	EB	0	0	0	0	0	
60th St	888	WB	0	-14	-103	0	0	
Park Ave	888	NB	0	0	0	0	0	
Park Ave	888	SB	0	0	-140	-17	0	-274
60th St & Madison Ave 2019 (TMC-030)	9							
	9	EB	0	0	0	0	0	
60th St	9	WB	0	0	-39	-81	0	
Madison Ave	9	NB	0	-11	-123	0	0	
	9	SB	0	0	0	0	0	-254
62nd St & Queensboror Bridge Exit 2019 (TMC-031)	10							
62nd St	10	EB	0	-4	-53	0	0	
	10	WB	0	0	0	0	0	
Queensboro Bridge Exit	10	NB	0	0	117	92	0	
	10	SB	0	0	0	0	0	152
60th St & 5th Ave 2019 (TMC-032)	11							
	11	EB	0	0	0	0	0	
60th St	11	WB	0	-23	-27	0	0	
	11	NB	0	0	0	0	0	
5th Ave	11	SB	0	0	-379	-123	0	-552

63rd St & York Ave 2019 (TMC-033)	12								
	12	EB	0	0	0	0	0		
63rd St	12	WB	0	-160	-118	-8	0		
York Ave	12	NB	0	0	-38	-137	0		
York Ave	12	SB	0	-60	-62	-1	0		-584
53rd St & FDR Drive 2019 (TMC-034)	13								
	13	EB	0	0	0	0	0		
53rd St	13	SW	0	0	0	-67	0		
	13	NB	0	0	0	0	0		
FDR Drive	13	SB	0	0	0	-39	0		-106
61st St & 5th Ave 2019 (TMC-035)	14								
	14	EB	0	0	0	0	0		
61st St	14	WB	0	-133	0	0	0		
	14	NB	0	0	0	0	0		
5th Ave	14	SB	0	0	-369	0	0		-502
65th St & 5th Ave 2019 (TMC-036)	15								
65th St	15	EB	0	0	-17	-5	0		
	15	WB	0	0	0	0	0		
	15	NB	0	0	0	0	0		
5th Ave	15	SB	0	-10	-93	0	0		-125
66th St & 5th Ave 2019 (TMC-037)	16								
	16	EB	0	0	0	0	0		
66th St	16	WB	0	-6	-49	0	0		
	16	NB	0	0	0	0	0		
5th Ave	16	SB	0	0	-97	-17	0		-169
79th St & 5th Ave 2019 (TMC-038)	17								
79th St	17	EB	0	0	-23	-7	0		
79th St	17	WB	0	-7	-59	0	0		
	17	NB	0	0	0	0	0		
5th Ave	17	SB	0	-5	-53	-8	0		-162
71st St & York Ave 2019 (TMC-039)	18								
	18	EB	0	0	0	0	0		
71st St	18	WB	0	-5	-2	-30	0		
York Ave	18	NB	0	-2	-132	0	0		
York Ave	18	SB	0	0	-136	-14	0		-321

CBD Tolling
UW #1 - Traffic Flowmap
AM Action Increment



- Legend:**
- 1 - Intersection (2019 Collected Data)
 - 7 - Intersection (Uncollected Data)
 - 100 - ATR Volume
 - 100 - Approach Volume

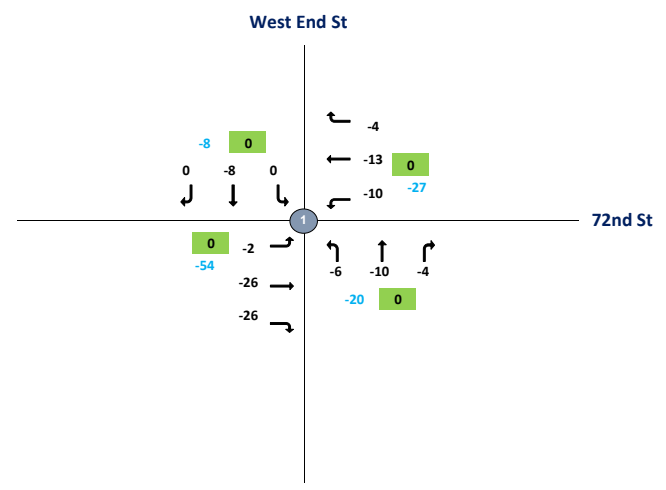

CBD Tolling
UW #2 - Traffic Flowmap
AM Action Increment



- Legend:**
- Intersection (2019 Collected Data)
 - Intersection (Uncollected Data)
 - 100 - ATR Volume
 - 100 - Approach Volume

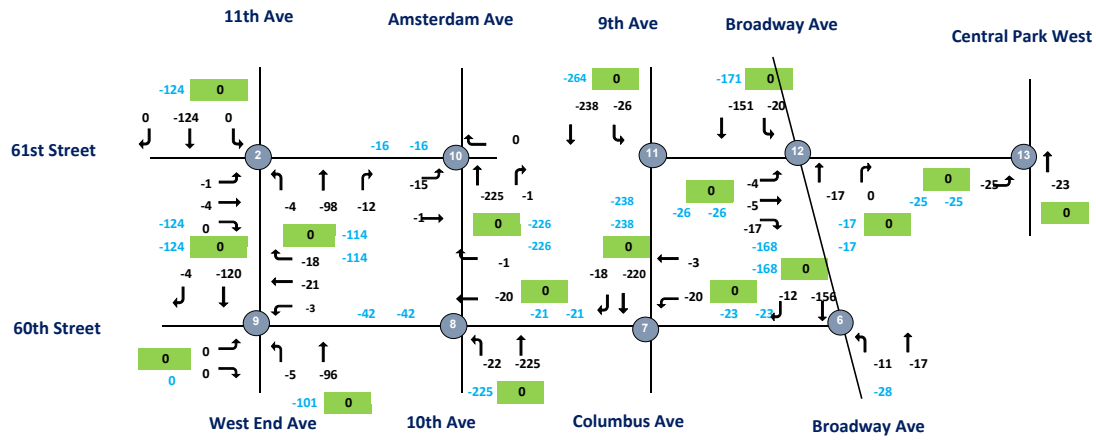

CBD Tolling
UW #3 - Traffic Flowmap
AM Action Increment



- Legend:**
- Intersection (2019 Collected Data)
 - 7 Intersection (Uncollected Data)
 - ATR Volume
 - Approach Volume

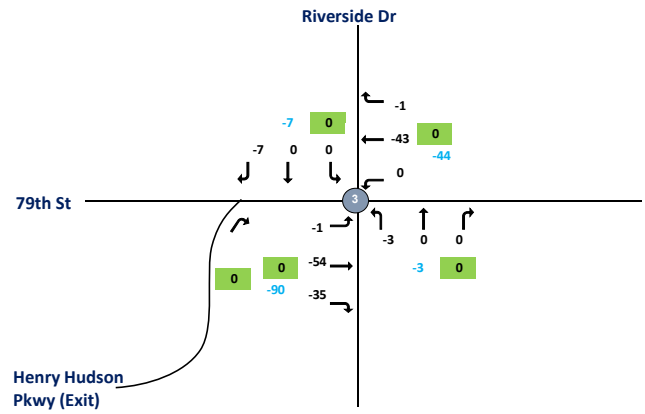

CBD Tolling
UW #4 - Traffic Flowmap
AM Action Increment



- Legend:**
- 1 - Intersection (2019 Collected Data)
 - 7 - Intersection (Uncollected Data)
 - 100 - ATR Volume
 - 100 - Approach Volume

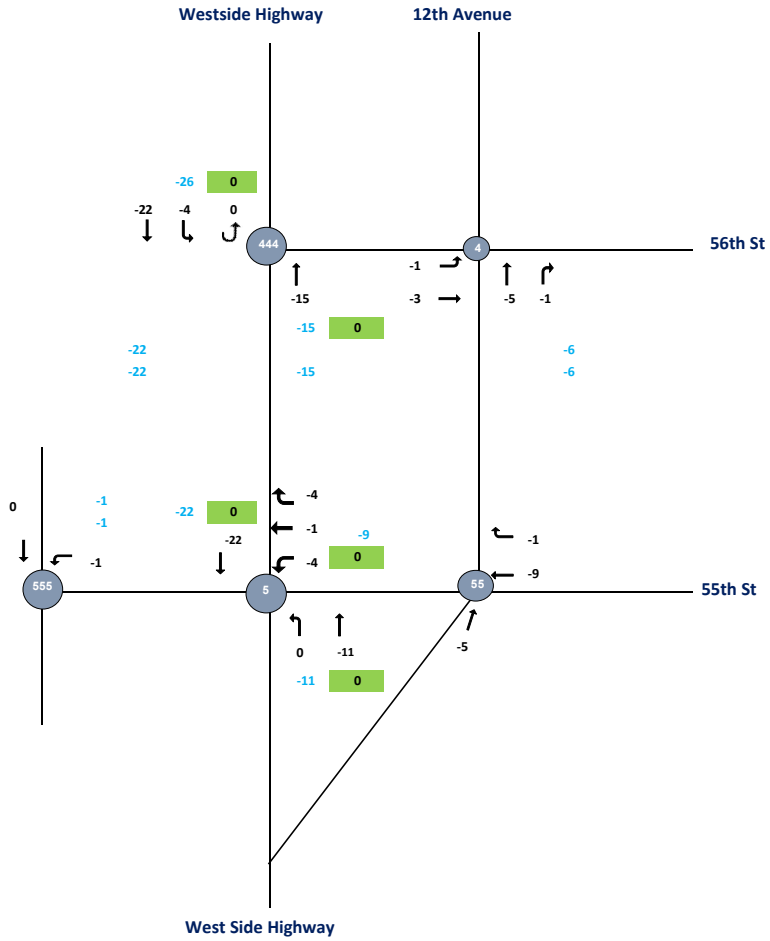

CBD Tolling
UW #5 - Traffic Flowmap
AM Action Increment



- Legend:**
- 1 - Intersection (2019 Collected Data)
 - 7 - Intersection (Uncollected Data)
 - 100 - ATR Volume
 - 100 - Approach Volume

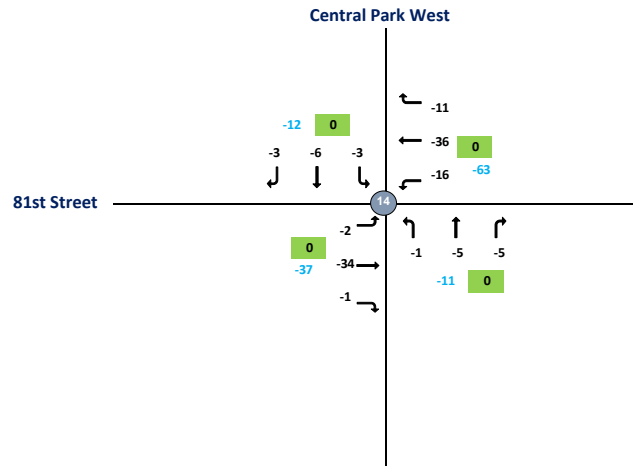

CBD Tolling
UW #6 - Traffic Flowmap
AM Action Increment



- Legend:**
- 1 - Intersection (2019 Collected Data)
 - 7 - Intersection (Uncollected Data)
 - 100 - ATR Volume
 - 100 - Approach Volume

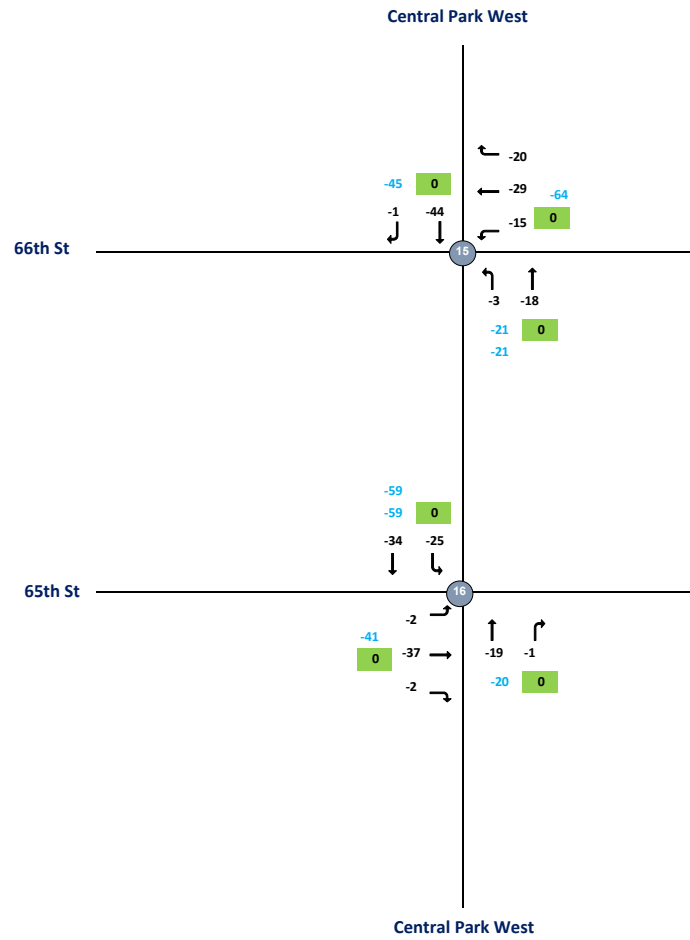

Intersection	Node	Approach	Total Vehicles					
			Inbound/Outbound					
			AM Peak Hour					
			L2	L	T	R	R2	Total
W 72nd St and West End St 2019 (TMC-042)	1							
W 72nd St	1	EB	0	-2	-26	-26	0	
W 72nd St	1	WB	0	-10	-13	-4	0	
West End St	1	NB	0	-6	-10	-4	0	
West End St	1	SB	0	0	-8	0	0	-109
W 61st St and West End St 2019 (TMC-043)	2							
W 61st St	2	EB	0	-1	-4	0	0	
W 61st St	2	WB	0	0	0	0	0	
West End St	2	NB	0	-4	-98	-12	0	
West End St	2	SB	0	0	-124	0	0	-243
W 79th St and Riverside Dr 2019 (TMC-044)	3	NEB						
W 79th St	3	EB	0	-1	-54	-35	0	
W 79th St	3	WB	0	0	-43	-1	0	
Riverside Dr	3	NB	0	-3	0	0	0	
Riverside Dr	3	SB	0	0	0	-7	0	-144
W 79th St and Riverside Dr 2019 (TMC-044)	333							
W 79th St	333	EB	0	0	0	0	0	
W 79th St	333	WB	0	0	0	0	0	
Riverside Dr	333	NB	0	0	0	0	0	
Riverside Dr	333	SB	0	0	0	0	0	0
W 56th St and West Side Hwy 2019 (TMC-045)	4							
-	4	EB	0	-1	-3	0	0	
W 56th St	4	WB	0	0	0	0	0	
West Side Hwy	4	NB	0	0	-5	-1	0	
West Side Hwy	4	SB	0	0	0	0	0	-10
W 56th St and West Side Hwy 2019 (TMC-045)	444							
-	444	EB	0	0	0	0	0	
W 56th St	444	WB	0	0	0	0	0	
West Side Hwy	444	NB	0	0	-15	0	0	
West Side Hwy	444	SB	0	-4	-22	0	0	-41
W 55th St and West Side Hwy 2019 (TMC-046)	5							
-	5	EB	0	0	0	0	0	
W 55th St	5	WB	0	-4	-1	-4	0	
West Side Hwy	5	NB	0	0	-11	0	0	
West Side Hwy	5	SB	0	0	-22	0	0	-42

W 55th St and West Side Hwy									
2019 (TMC-046 B B)		55							
-		55	EB	0	0	0	0	0	
W 55th St		55	WB	0	0	-9	-1	0	
West Side Hwy		55	NB	0	0	-5	0	0	
West Side Hwy		55	SB	0	0	0	0	0	-15
W 55th St and West Side Hwy									
2019 (TMC-046)		555							
-		555	EB	0	0	0	0	0	
W 55th St		555	WB	0	-1	0	0	0	
West Side Hwy		555	NB	0	0	0	0	0	
West Side Hwy		555	SB	0	0	0	0	0	-1
W 60th St and Broadway									
2019 (TMC-047)		6							
-		6	EB	0	0	0	0	0	
W 60th St		6	WB	0	0	0	0	0	
Broadway		6	NB	0	-11	-17	0	0	
Broadway		6	SB	0	0	-156	-12	0	-196
W 60th St and Columbus Ave									
2019 (TMC-048)		7							
W 60th St		7	EB	0	0	0	0	0	
W 60th St		7	WB	0	-20	-3	0	0	
Columbus Ave		7	NB	0	0	0	0	0	
Columbus Ave		7	SB	0	0	-220	-18	0	-261
W 60th St and 10th Ave									
2019 (TMC-049)		8							
W 60th St		8	EB	0	0	0	0	0	
W 60th St		8	WB	0	0	-20	-1	0	
10th Ave		8	NB	0	-22	-225	0	0	
10th Ave		8	SB	0	0	0	0	0	-268
W 60th St and 11th Ave									
2019 (TMC-050)		9							
W 60th St		9	EB	0	0	0	0	0	
W 60th St		9	WB	0	-3	-21	-18	0	
11th Ave		9	NB	0	-5	-96	0	0	
11th Ave		9	SB	0	0	-120	-4	0	-267
W 61st St and 10th Ave									
2019 (TMC-051)		10							
W 61st St		10	EB	0	-15	-1	0	0	
W 61st St		10	WB	0	0	0	0	0	
10th Ave		10	NB	0	0	-225	-1	0	
10th Ave		10	SB	0	0	0	0	0	-242

W 61st St and Columbus Ave									
2019 (TMC-052)	11								
-	11	EB	0	0	0	0	0		
W 61st St	11	WB	0	0	0	0	0		
Columbus Ave	11	NB	0	0	0	0	0		
Columbus Ave	11	SB	0	-26	-238	0	0		-264
W 61st St and Broadway									
2019 (TMC-053)	12								
W 61st St	12	EB	0	-4	-5	-17	0		
W 61st St	12	WB	0	0	0	0	0		
Broadway	12	NB	0	0	-17	0	0		
Broadway	12	SB	0	-20	-151	0	0		-214
Central Park and W 61st St									
2019 (TMC-054)	13								
W 61st St	13	EB	0	-25	0	0	0		
-	13	WB	0	0	0	0	0		
Central Park	13	NB	0	0	-23	0	0		
Central Park	13	SB	0	0	0	0	0		-48
Central Park and W 81st St									
2019 (TMC-055)	14								
W 81st St	14	EB	0	-2	-34	-1	0		
W 79th St Transverse	14	WB	0	-16	-36	-11	0		
Central Park	14	NB	0	-1	-5	-5	0		
Central Park	14	SB	0	-3	-6	-3	0		-123
Central Park West and W 66th St									
2019 (TMC-056)	15								
W 66th St	15	EB	0	0	0	0	0		
W 66th St	15	WB	0	-15	-29	-20	0		
Central Park West	15	NB	0	-3	-18	0	0		
Central Park West	15	SB	0	0	-44	-1	0		-130
Central Park West and W 65th St									
2019 (TMC-057)	16								
W 65th St	16	EB	0	-2	-37	-2	0		
W 65th St	16	WB	0	0	0	0	0		
Central Park West	16	NB	0	0	-19	-1	0		
Central Park West	16	SB	0	-25	-34	0	0		-120

CBD Tolling
UW #1 - Traffic Flowmap
MD Action Increment



- Legend:**
- 1 - Intersection (2019 Collected Data)
 - 7 - Intersection (Uncollected Data)
 - 100 - ATR Volume
 - 100 - Approach Volume

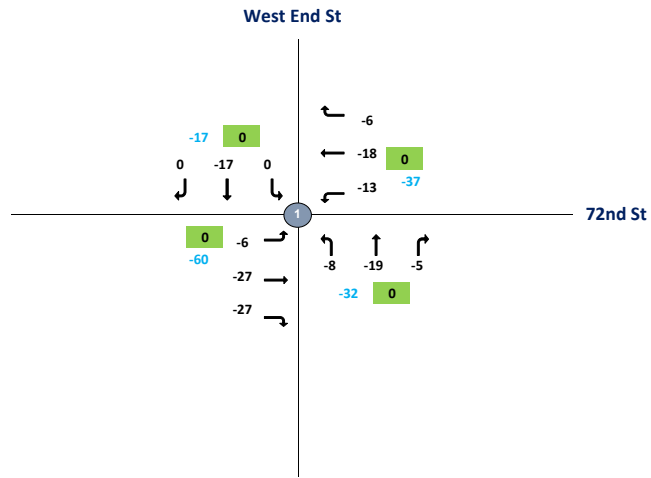

CBD Tolling
UW #2 - Traffic Flowmap
MD Action Increment



- Legend:**
- 1 - Intersection (2019 Collected Data)
 - 2 - Intersection (Uncollected Data)
 - 100 - ATR Volume
 - 100 - Approach Volume

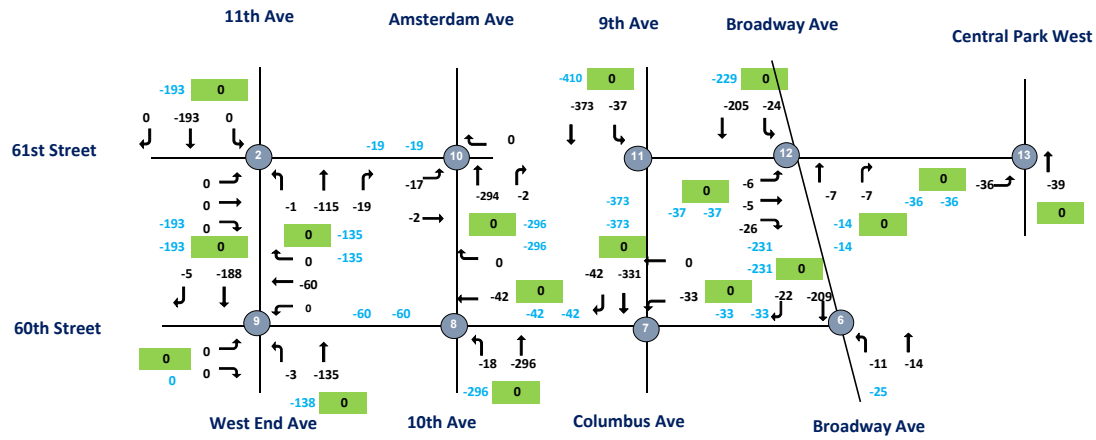

CBD Tolling
UW #3 - Traffic Flowmap
MD Action Increment



- Legend:**
- Intersection (2019 Collected Data)
 - 7 Intersection (Uncollected Data)
 - 100 - ATR Volume
 - 100 - Approach Volume

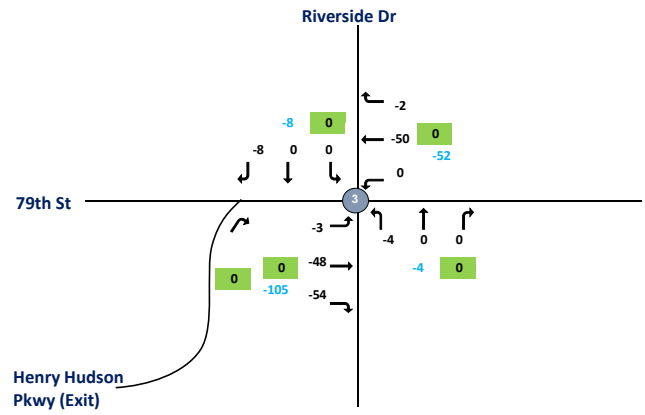

CBD Tolling
UW #4 - Traffic Flowmap
MD Action Increment



- Legend:**
- 1 - Intersection (2019 Collected Data)
 - 7 - Intersection (Uncollected Data)
 - 100 - ATR Volume
 - 100 - Approach Volume

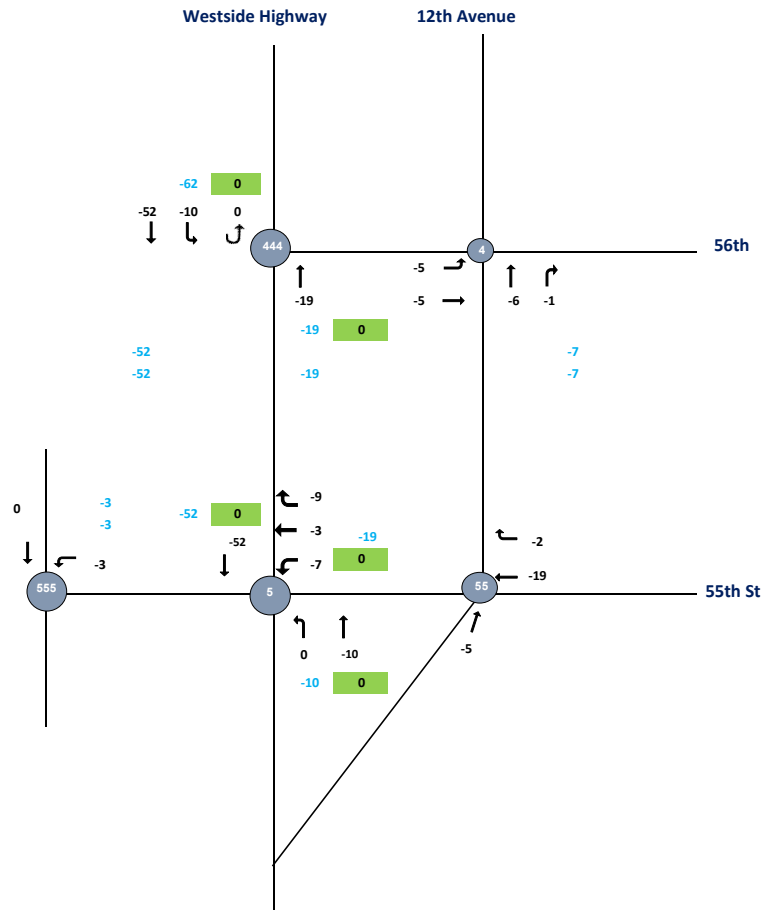

CBD Tolling
UW #5 - Traffic Flowmap
MD Action Increment



- Legend:**
- 1 - Intersection (2019 Collected Data)
 - 7 - Intersection (Uncollected Data)
 - 100 - ATR Volume
 - 100 - Approach Volume

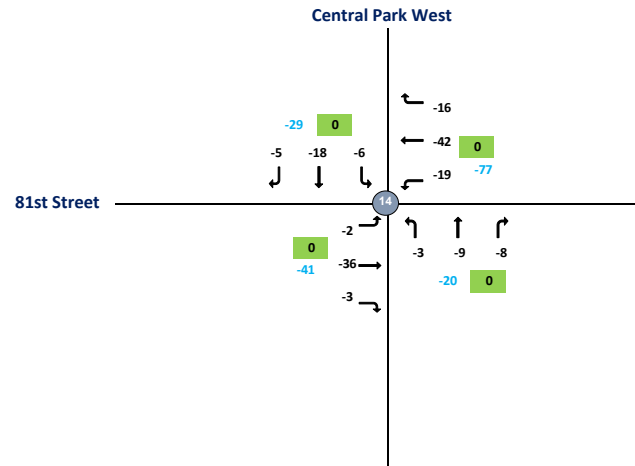

CBD Tolling
UW #6 - Traffic Flowmap
MD Action Increment



- Legend:**
- 1 - Intersection (2019 Collected Data)
 - 7 - Intersection (Uncollected Data)
 - 100 - ATR Volume
 - 100 - Approach Volume

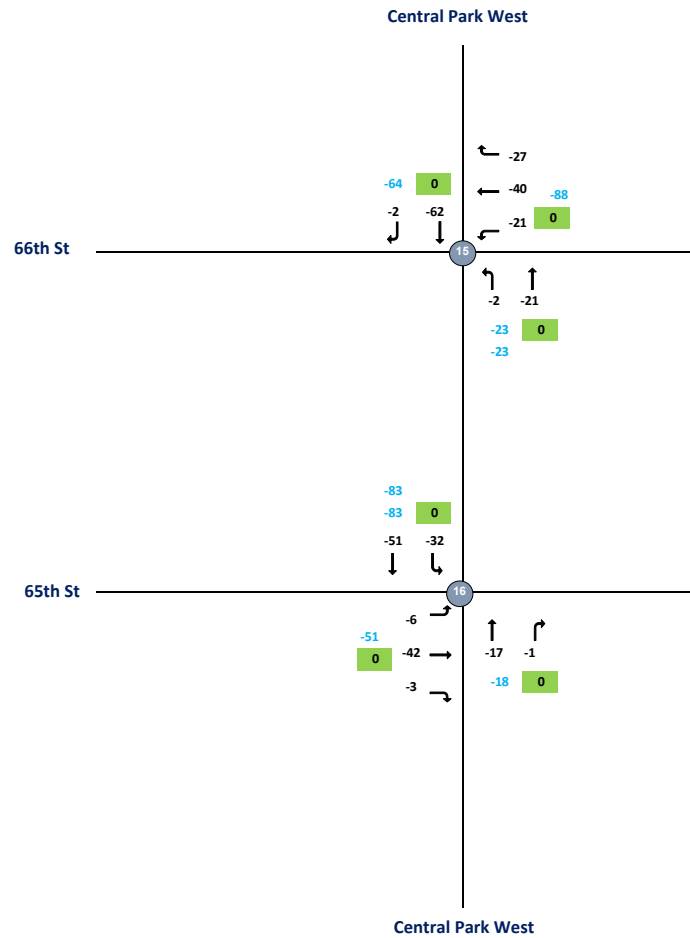

Intersection	Node	Approach	Total Vehicles					
			Inbound/Outbound					
			MD Peak Hour					
			L2	L	T	R	R2	Total
W 72nd St and West End St 2019 (TMC-042)	1							
W 72nd St	1	EB	0	-6	-27	-27	0	
W 72nd St	1	WB	0	-13	-18	-6	0	
West End St	1	NB	0	-8	-19	-5	0	
West End St	1	SB	0	0	-17	0	0	-146
W 61st St and West End St 2019 (TMC-043)	2							
W 61st St	2	EB	0	0	0	0	0	
W 61st St	2	WB	0	0	0	0	0	
West End St	2	NB	0	-1	-115	-19	0	
West End St	2	SB	0	0	-193	0	0	-328
W 79th St and Riverside Dr 2019 (TMC-044)	3	NEB						
W 79th St	3	EB	0	-3	-48	-54	0	
W 79th St	3	WB	0	0	-50	-2	0	
Riverside Dr	3	NB	0	-4	0	0	0	
Riverside Dr	3	SB	0	0	0	-8	0	-169
W 79th St and Riverside Dr 2019 (TMC-044)	333							
W 79th St	333	EB	0	0	0	0	0	
W 79th St	333	WB	0	0	0	0	0	
Riverside Dr	333	NB	0	0	0	0	0	
Riverside Dr	333	SB	0	0	0	0	0	0
W 56th St and West Side Hwy 2019 (TMC-045)	4							
-	4	EB	0	-5	-5	0	0	
W 56th St	4	WB	0	0	0	0	0	
West Side Hwy	4	NB	0	0	-6	-1	0	
West Side Hwy	4	SB	0	0	0	0	0	-17
W 56th St and West Side Hwy 2019 (TMC-045)	444							
-	444	EB	0	0	0	0	0	
W 56th St	444	WB	0	0	0	0	0	
West Side Hwy	444	NB	0	0	-19	0	0	
West Side Hwy	444	SB	0	-10	-52	0	0	-81
W 55th St and West Side Hwy 2019 (TMC-046)	5							
-	5	EB	0	0	0	0	0	
W 55th St	5	WB	0	-7	-3	-9	0	
West Side Hwy	5	NB	0	0	-10	0	0	
West Side Hwy	5	SB	0	0	-52	0	0	-81

W 55th St and West Side Hwy									
2019 (TMC-046 B B)		55							
-	55	EB	0	0	0	0	0		
W 55th St	55	WB	0	0	-19	-2	0		
West Side Hwy	55	NB	0	0	-5	0	0		
West Side Hwy	55	SB	0	0	0	0	0		-26
W 55th St and West Side Hwy									
2019 (TMC-046)		555							
-	555	EB	0	0	0	0	0		
W 55th St	555	WB	0	-3	0	0	0		
West Side Hwy	555	NB	0	0	0	0	0		
West Side Hwy	555	SB	0	0	0	0	0		-3
W 60th St and Broadway									
2019 (TMC-047)		6							
-	6	EB	0	0	0	0	0		
W 60th St	6	WB	0	0	0	0	0		
Broadway	6	NB	0	-11	-14	0	0		
Broadway	6	SB	0	0	-209	-22	0		-256
W 60th St and Columbus Ave									
2019 (TMC-048)		7							
W 60th St	7	EB	0	0	0	0	0		
W 60th St	7	WB	0	-33	0	0	0		
Columbus Ave	7	NB	0	0	0	0	0		
Columbus Ave	7	SB	0	0	-331	-42	0		-406
W 60th St and 10th Ave									
2019 (TMC-049)		8							
W 60th St	8	EB	0	0	0	0	0		
W 60th St	8	WB	0	0	-42	0	0		
10th Ave	8	NB	0	-18	-296	0	0		
10th Ave	8	SB	0	0	0	0	0		-356
W 60th St and 11th Ave									
2019 (TMC-050)		9							
W 60th St	9	EB	0	0	0	0	0		
W 60th St	9	WB	0	0	-60	0	0		
11th Ave	9	NB	0	-3	-135	0	0		
11th Ave	9	SB	0	0	-188	-5	0		-391
W 61st St and 10th Ave									
2019 (TMC-051)		10							
W 61st St	10	EB	0	-17	-2	0	0		
W 61st St	10	WB	0	0	0	0	0		
10th Ave	10	NB	0	0	-294	-2	0		
10th Ave	10	SB	0	0	0	0	0		-315

W 61st St and Columbus Ave									
2019 (TMC-052)	11								
-	11	EB	0	0	0	0	0		
W 61st St	11	WB	0	0	0	0	0		
Columbus Ave	11	NB	0	0	0	0	0		
Columbus Ave	11	SB	0	-37	-373	0	0		-410
W 61st St and Broadway									
2019 (TMC-053)	12								
W 61st St	12	EB	0	-6	-5	-26	0		
W 61st St	12	WB	0	0	0	0	0		
Broadway	12	NB	0	0	-7	-7	0		
Broadway	12	SB	0	-24	-205	0	0		-280
Central Park and W 61st St									
2019 (TMC-054)	13								
W 61st St	13	EB	0	-36	0	0	0		
-	13	WB	0	0	0	0	0		
Central Park	13	NB	0	0	-39	0	0		
Central Park	13	SB	0	0	0	0	0		-75
Central Park and W 81st St									
2019 (TMC-055)	14								
W 81st St	14	EB	0	-2	-36	-3	0		
W 79th St Transverse	14	WB	0	-19	-42	-16	0		
Central Park	14	NB	0	-3	-9	-8	0		
Central Park	14	SB	0	-6	-18	-5	0		-167
Central Park West and W 66th St									
2019 (TMC-056)	15								
W 66th St	15	EB	0	0	0	0	0		
W 66th St	15	WB	0	-21	-40	-27	0		
Central Park West	15	NB	0	-2	-21	0	0		
Central Park West	15	SB	0	0	-62	-2	0		-175
Central Park West and W 65th St									
2019 (TMC-057)	16								
W 65th St	16	EB	0	-6	-42	-3	0		
W 65th St	16	WB	0	0	0	0	0		
Central Park West	16	NB	0	0	-17	-1	0		
Central Park West	16	SB	0	-32	-51	0	0		-152

CBD Tolling
UW #1 - Traffic Flowmap
PM Action Increment



- Legend:**
- 1 - Intersection (2019 Collected Data)
 - 7 - Intersection (Uncollected Data)
 - 100 - ATR Volume
 - 100 - Approach Volume

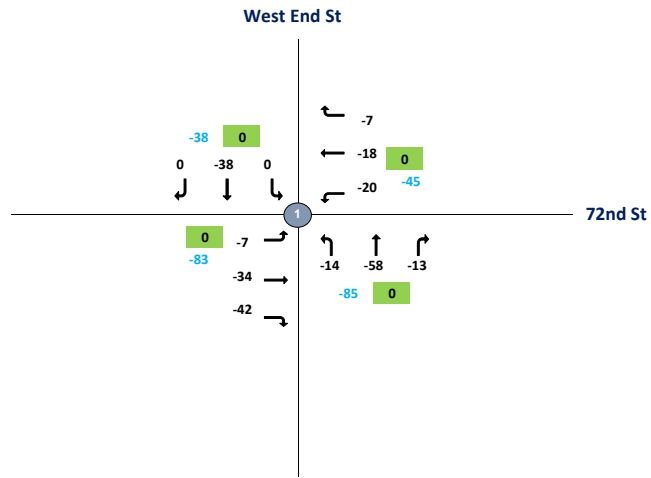

CBD Tolling
UW #2 - Traffic Flowmap
PM Action Increment



- Legend:**
- 1 - Intersection (2019 Collected Data)
 - 2 - Intersection (Uncollected Data)
 - 100 - ATR Volume
 - 100 - Approach Volume

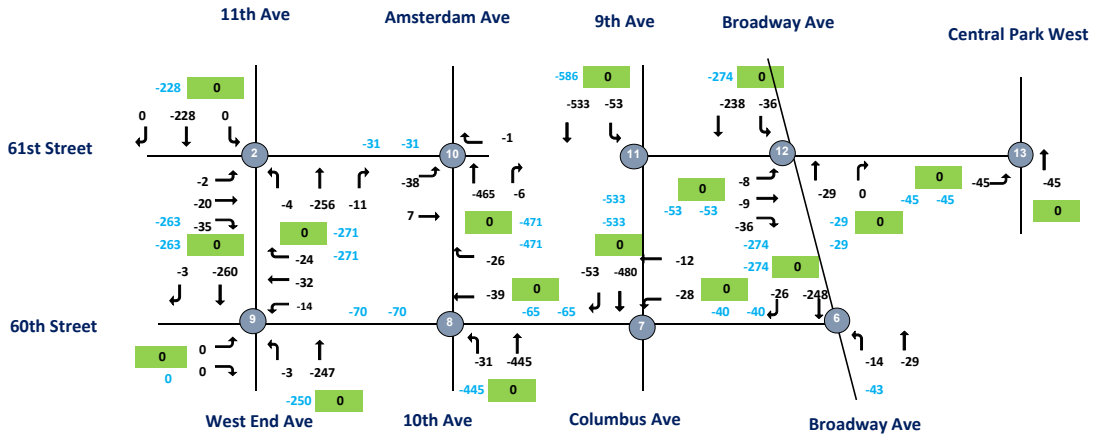

CBD Tolling
UW #3 - Traffic Flowmap
PM Action Increment



- Legend:**
- 1 - Intersection (2019 Collected Data)
 - 7 - Intersection (Uncollected Data)
 - 100 - ATR Volume
 - 100 - Approach Volume

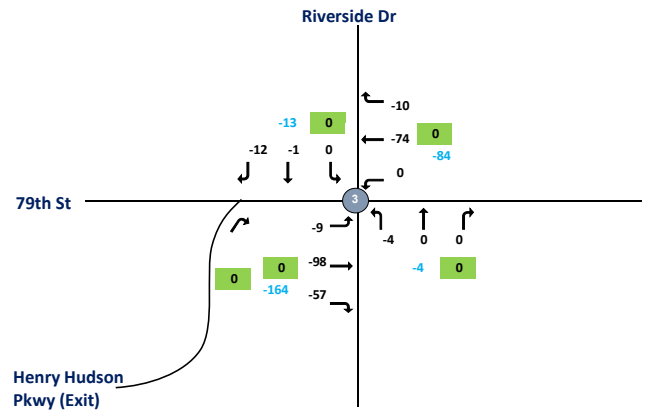

CBD Tolling
UW #4 - Traffic Flowmap
PM Action Increment



- Legend:**
- 1 - Intersection (2019 Collected Data)
 - 7 - Intersection (Uncollected Data)
 - 100 - ATR Volume
 - 100 - Approach Volume

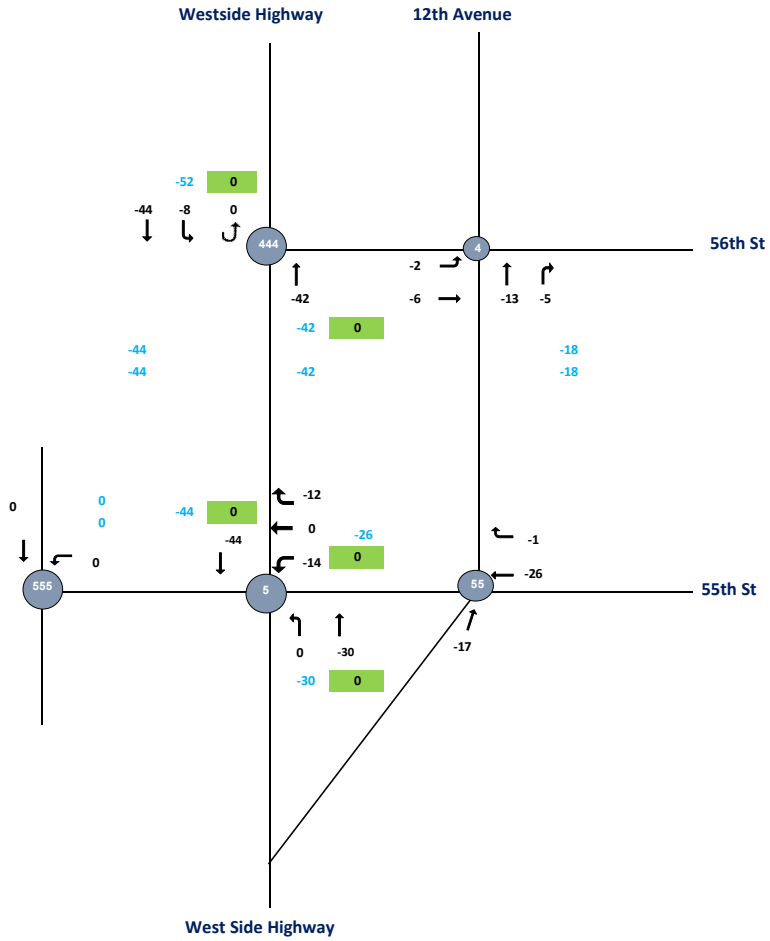

CBD Tolling
UW #5 - Traffic Flowmap
PM Action Increment



- Legend:**
- 1 - Intersection (2019 Collected Data)
 - 7 - Intersection (Uncollected Data)
 - 100 - ATR Volume
 - 100 - Approach Volume

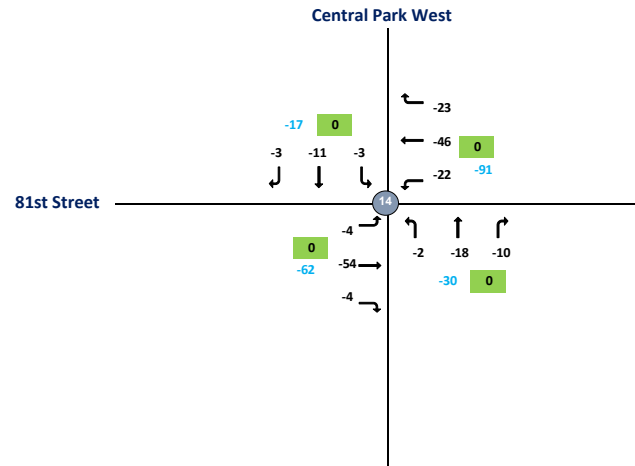

CBD Tolling
UW #6 - Traffic Flowmap
PM Action Increment



- Legend:**
- 1 - Intersection (2019 Collected Data)
 - 7 - Intersection (Uncollected Data)
 - 100 - ATR Volume
 - 100 - Approach Volume

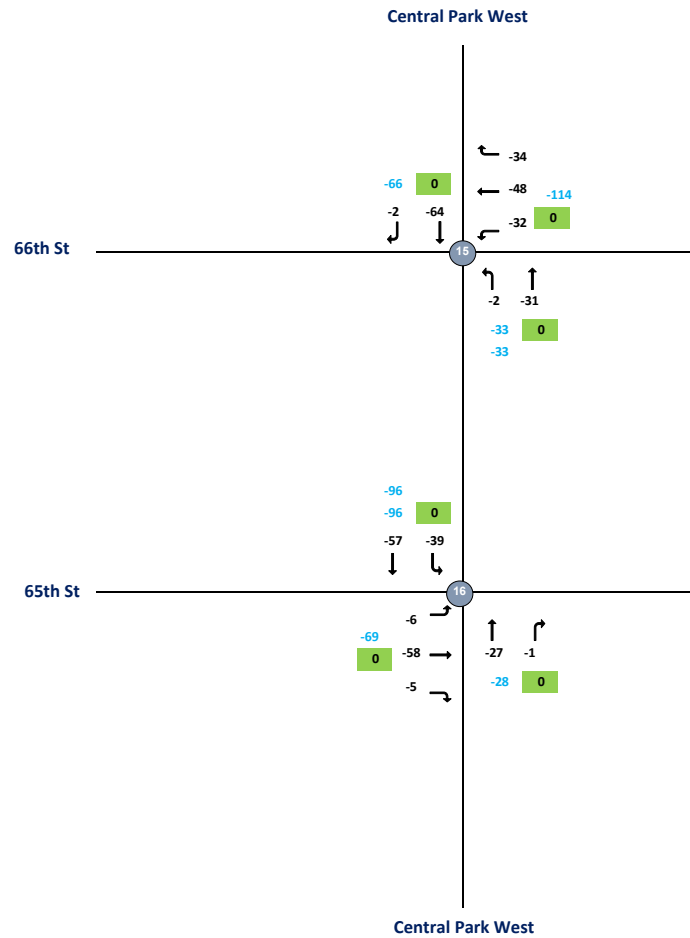

Intersection	Node	Approach	Total Vehicles					
			Inbound/Outbound					
			PM Peak Hour					
			L2	L	T	R	R2	Total
W 72nd St and West End St 2019 (TMC-042)	1							
W 72nd St	1	EB	0	-7	-34	-42	0	
W 72nd St	1	WB	0	-20	-18	-7	0	
West End St	1	NB	0	-14	-58	-13	0	
West End St	1	SB	0	0	-38	0	0	-251
W 61st St and West End St 2019 (TMC-043)	2							
W 61st St	2	EB	0	-2	-20	-35	0	
W 61st St	2	WB	0	0	0	0	0	
West End St	2	NB	0	-4	-256	-11	0	
West End St	2	SB	0	0	-228	0	0	-556
W 79th St and Riverside Dr 2019 (TMC-044)	3	NEB						
W 79th St	3	EB	0	-9	-98	-57	0	
W 79th St	3	WB	0	0	-74	-10	0	
Riverside Dr	3	NB	0	-4	0	0	0	
Riverside Dr	3	SB	0	0	-1	-12	0	-265
W 79th St and Riverside Dr 2019 (TMC-044)	333							
W 79th St	333	EB	0	0	0	0	0	
W 79th St	333	WB	0	0	0	0	0	
Riverside Dr	333	NB	0	0	0	0	0	
Riverside Dr	333	SB	0	0	0	0	0	0
W 56th St and West Side Hwy 2019 (TMC-045)	4							
-	4	EB	0	-2	-6	0	0	
W 56th St	4	WB	0	0	0	0	0	
West Side Hwy	4	NB	0	0	-13	-5	0	
West Side Hwy	4	SB	0	0	0	0	0	-26
W 56th St and West Side Hwy 2019 (TMC-045)	444							
-	444	EB	0	0	0	0	0	
W 56th St	444	WB	0	0	0	0	0	
West Side Hwy	444	NB	0	0	-42	0	0	
West Side Hwy	444	SB	0	-8	-44	0	0	-94
W 55th St and West Side Hwy 2019 (TMC-046)	5							
-	5	EB	0	0	0	0	0	
W 55th St	5	WB	0	-14	0	-12	0	
West Side Hwy	5	NB	0	0	-30	0	0	
West Side Hwy	5	SB	0	0	-44	0	0	-100

W 55th St and West Side Hwy									
2019 (TMC-046 B B)		55							
-	55	EB	0	0	0	0	0		
W 55th St	55	WB	0	0	-26	-1	0		
West Side Hwy	55	NB	0	0	-17	0	0		
West Side Hwy	55	SB	0	0	0	0	0		-44
W 55th St and West Side Hwy									
2019 (TMC-046)		555							
-	555	EB	0	0	0	0	0		
W 55th St	555	WB	0	0	0	0	0		
West Side Hwy	555	NB	0	0	0	0	0		
West Side Hwy	555	SB	0	0	0	0	0		0
W 60th St and Broadway									
2019 (TMC-047)		6							
-	6	EB	0	0	0	0	0		
W 60th St	6	WB	0	0	0	0	0		
Broadway	6	NB	0	-14	-29	0	0		
Broadway	6	SB	0	0	-248	-26	0		-317
W 60th St and Columbus Ave									
2019 (TMC-048)		7							
W 60th St	7	EB	0	0	0	0	0		
W 60th St	7	WB	0	-28	-12	0	0		
Columbus Ave	7	NB	0	0	0	0	0		
Columbus Ave	7	SB	0	0	-480	-53	0		-573
W 60th St and 10th Ave									
2019 (TMC-049)		8							
W 60th St	8	EB	0	0	0	0	0		
W 60th St	8	WB	0	0	-39	-26	0		
10th Ave	8	NB	0	-31	-445	0	0		
10th Ave	8	SB	0	0	0	0	0		-541
W 60th St and 11th Ave									
2019 (TMC-050)		9							
W 60th St	9	EB	0	0	0	0	0		
W 60th St	9	WB	0	-14	-32	-24	0		
11th Ave	9	NB	0	-3	-247	0	0		
11th Ave	9	SB	0	0	-260	-3	0		-583
W 61st St and 10th Ave									
2019 (TMC-051)		10							
W 61st St	10	EB	0	-38	7	0	0		
W 61st St	10	WB	0	0	0	-1	0		
10th Ave	10	NB	0	0	-465	-6	0		
10th Ave	10	SB	0	0	0	0	0		-503

W 61st St and Columbus Ave									
2019 (TMC-052)	11								
-	11	EB	0	0	0	0	0		
W 61st St	11	WB	0	0	0	0	0		
Columbus Ave	11	NB	0	0	0	0	0		
Columbus Ave	11	SB	0	-53	-533	0	0		-586
W 61st St and Broadway									
2019 (TMC-053)	12								
W 61st St	12	EB	0	-8	-9	-36	0		
W 61st St	12	WB	0	0	0	0	0		
Broadway	12	NB	0	0	-29	0	0		
Broadway	12	SB	0	-36	-238	0	0		-356
Central Park and W 61st St									
2019 (TMC-054)	13								
W 61st St	13	EB	0	-45	0	0	0		
-	13	WB	0	0	0	0	0		
Central Park	13	NB	0	0	-45	0	0		
Central Park	13	SB	0	0	0	0	0		-90
Central Park and W 81st St									
2019 (TMC-055)	14								
W 81st St	14	EB	0	-4	-54	-4	0		
W 79th St Transverse	14	WB	0	-22	-46	-23	0		
Central Park	14	NB	0	-2	-18	-10	0		
Central Park	14	SB	0	-3	-11	-3	0		-200
Central Park West and W 66th St									
2019 (TMC-056)	15								
W 66th St	15	EB	0	0	0	0	0		
W 66th St	15	WB	0	-32	-48	-34	0		
Central Park West	15	NB	0	-2	-31	0	0		
Central Park West	15	SB	0	0	-64	-2	0		-213
Central Park West and W 65th St									
2019 (TMC-057)	16								
W 65th St	16	EB	0	-6	-58	-5	0		
W 65th St	16	WB	0	0	0	0	0		
Central Park West	16	NB	0	0	-27	-1	0		
Central Park West	16	SB	0	-39	-57	0	0		-193

CBD Tolling
UW #1 - Traffic Flowmap
LN Action Increment



- Legend:**
- 1 - Intersection (2019 Collected Data)
 - 7 - Intersection (Uncollected Data)
 - 100 - ATR Volume
 - 100 - Approach Volume

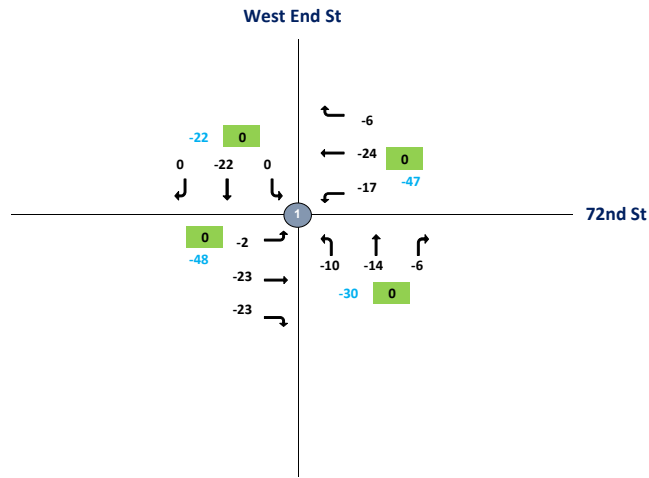

CBD Tolling
UW #2 - Traffic Flowmap
LN Action Increment



- Legend:**
- 1 - Intersection (2019 Collected Data)
 - 2 - Intersection (Uncollected Data)
 - 100 - ATR Volume
 - 100 - Approach Volume

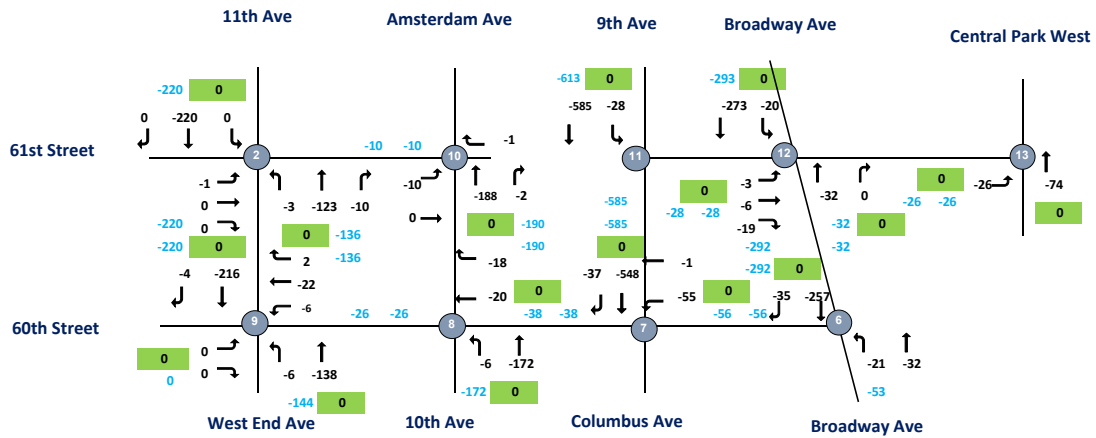

CBD Tolling
UW #3 - Traffic Flowmap
LN Action Increment



- Legend:**
- Intersection (2019 Collected Data)
 - 7 Intersection (Uncollected Data)
 - ATR Volume
 - Approach Volume

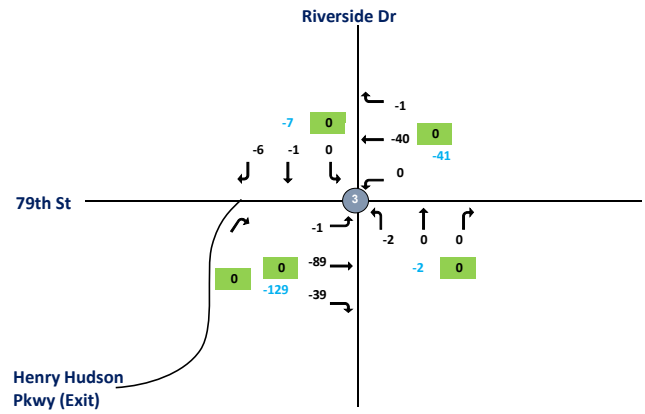

CBD Tolling
UW #4 - Traffic Flowmap
LN Action Increment



- Legend:**
- 1 - Intersection (2019 Collected Data)
 - 7 - Intersection (Uncollected Data)
 - 100 - ATR Volume
 - 100 - Approach Volume

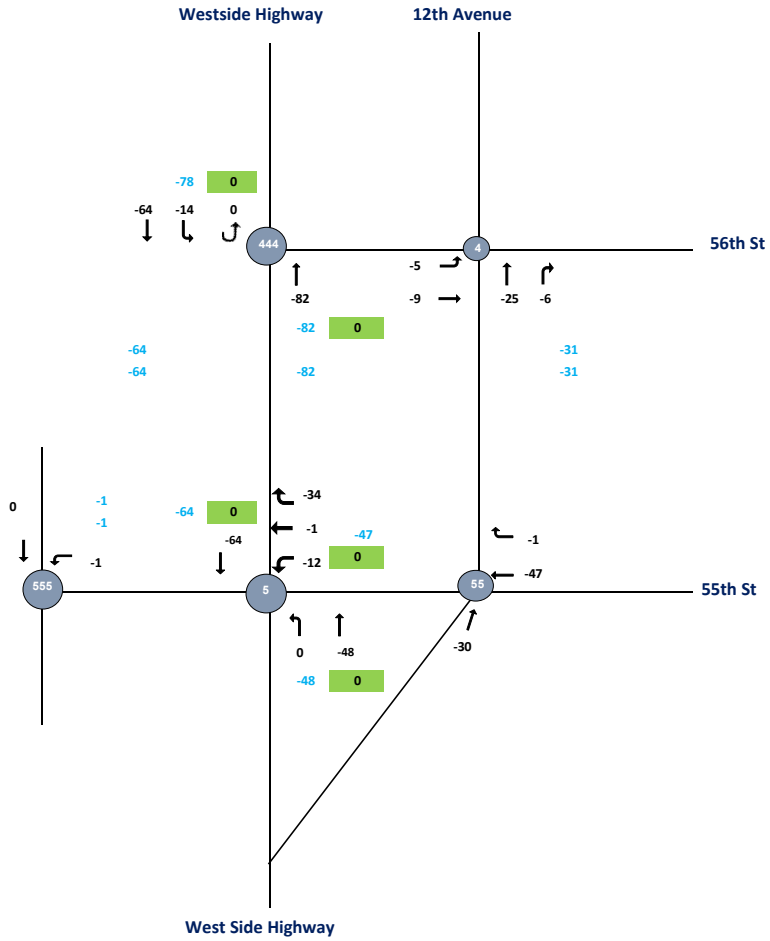

CBD Tolling
UW #5 - Traffic Flowmap
LN Action Increment



- Legend:**
- 1 - Intersection (2019 Collected Data)
 - 7 - Intersection (Uncollected Data)
 - 100 - ATR Volume
 - 100 - Approach Volume

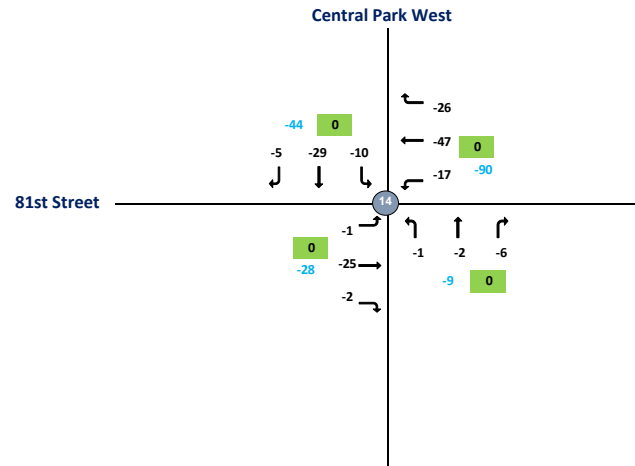

CBD Tolling
UW #6 - Traffic Flowmap
LN Action Increment



- Legend:**
- 1 - Intersection (2019 Collected Data)
 - 7 - Intersection (Uncollected Data)
 - 100 - ATR Volume
 - 100 - Approach Volume

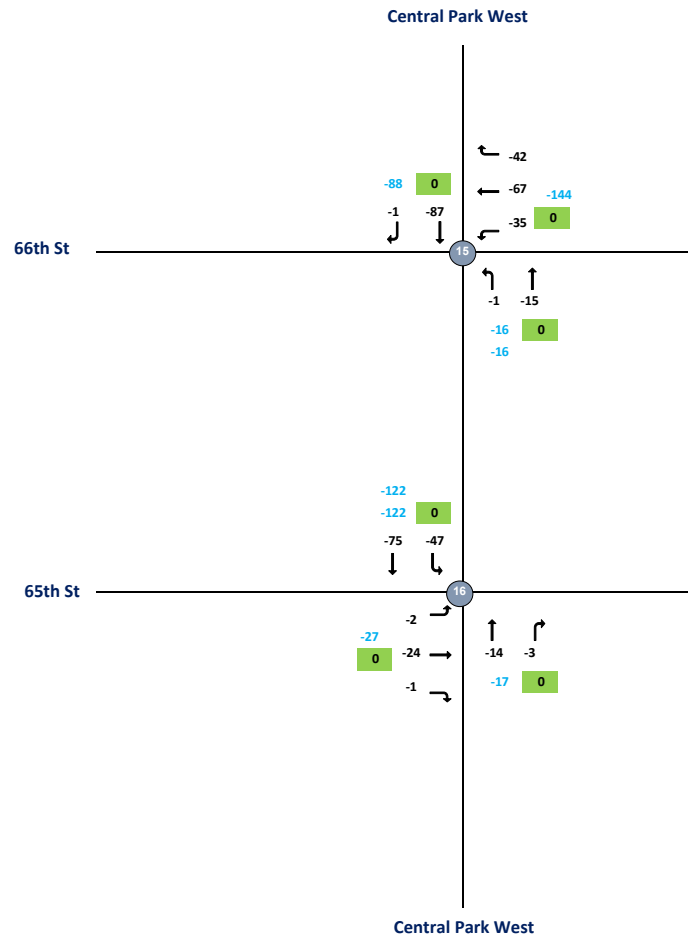





Intersection	Node	Approach	Total Vehicles					
			Inbound/Outbound					
			LN Peak Hour					
			L2	L	T	R	R2	Total
W 72nd St and West End St 2019 (TMC-042)	1							
W 72nd St	1	EB	0	-2	-23	-23	0	
W 72nd St	1	WB	0	-17	-24	-6	0	
West End St	1	NB	0	-10	-14	-6	0	
West End St	1	SB	0	0	-22	0	0	-147
W 61st St and West End St 2019 (TMC-043)	2							
W 61st St	2	EB	0	-1	0	0	0	
W 61st St	2	WB	0	0	0	0	0	
West End St	2	NB	0	-3	-123	-10	0	
West End St	2	SB	0	0	-220	0	0	-357
W 79th St and Riverside Dr 2019 (TMC-044)	3	NEB						
W 79th St	3	EB	0	-1	-89	-39	0	
W 79th St	3	WB	0	0	-40	-1	0	
Riverside Dr	3	NB	0	-2	0	0	0	
Riverside Dr	3	SB	0	0	-1	-6	0	-179
W 79th St and Riverside Dr 2019 (TMC-044)	333							
W 79th St	333	EB	0	0	0	0	0	
W 79th St	333	WB	0	0	0	0	0	
Riverside Dr	333	NB	0	0	0	0	0	
Riverside Dr	333	SB	0	0	0	0	0	0
W 56th St and West Side Hwy 2019 (TMC-045)	4							
-	4	EB	0	-5	-9	0	0	
W 56th St	4	WB	0	0	0	0	0	
West Side Hwy	4	NB	0	0	-25	-6	0	
West Side Hwy	4	SB	0	0	0	0	0	-45
W 56th St and West Side Hwy 2019 (TMC-045)	444							
-	444	EB	0	0	0	0	0	
W 56th St	444	WB	0	0	0	0	0	
West Side Hwy	444	NB	0	0	-82	0	0	
West Side Hwy	444	SB	0	-14	-64	0	0	-160
W 55th St and West Side Hwy 2019 (TMC-046)	5							
-	5	EB	0	0	0	0	0	
W 55th St	5	WB	0	-12	-1	-34	0	
West Side Hwy	5	NB	0	0	-48	0	0	
West Side Hwy	5	SB	0	0	-64	0	0	-159

W 55th St and West Side Hwy									
2019 (TMC-046 B B)		55							
-		55	EB	0	0	0	0	0	
W 55th St		55	WB	0	0	-47	-1	0	
West Side Hwy		55	NB	0	0	-30	0	0	
West Side Hwy		55	SB	0	0	0	0	0	-78
W 55th St and West Side Hwy									
2019 (TMC-046)		555							
-		555	EB	0	0	0	0	0	
W 55th St		555	WB	0	-1	0	0	0	
West Side Hwy		555	NB	0	0	0	0	0	
West Side Hwy		555	SB	0	0	0	0	0	-1
W 60th St and Broadway									
2019 (TMC-047)		6							
-		6	EB	0	0	0	0	0	
W 60th St		6	WB	0	0	0	0	0	
Broadway		6	NB	0	-21	-32	0	0	
Broadway		6	SB	0	0	-257	-35	0	-345
W 60th St and Columbus Ave									
2019 (TMC-048)		7							
W 60th St		7	EB	0	0	0	0	0	
W 60th St		7	WB	0	-55	-1	0	0	
Columbus Ave		7	NB	0	0	0	0	0	
Columbus Ave		7	SB	0	0	-548	-37	0	-641
W 60th St and 10th Ave									
2019 (TMC-049)		8							
W 60th St		8	EB	0	0	0	0	0	
W 60th St		8	WB	0	0	-20	-18	0	
10th Ave		8	NB	0	-6	-172	0	0	
10th Ave		8	SB	0	0	0	0	0	-216
W 60th St and 11th Ave									
2019 (TMC-050)		9							
W 60th St		9	EB	0	0	0	0	0	
W 60th St		9	WB	0	-6	-22	2	0	
11th Ave		9	NB	0	-6	-138	0	0	
11th Ave		9	SB	0	0	-216	-4	0	-390
W 61st St and 10th Ave									
2019 (TMC-051)		10							
W 61st St		10	EB	0	-10	0	0	0	
W 61st St		10	WB	0	0	0	-1	0	
10th Ave		10	NB	0	0	-188	-2	0	
10th Ave		10	SB	0	0	0	0	0	-201

W 61st St and Columbus Ave									
2019 (TMC-052)	11								
-	11	EB	0	0	0	0	0		
W 61st St	11	WB	0	0	0	0	0		
Columbus Ave	11	NB	0	0	0	0	0		
Columbus Ave	11	SB	0	-28	-585	0	0		-613
W 61st St and Broadway									
2019 (TMC-053)	12								
W 61st St	12	EB	0	-3	-6	-19	0		
W 61st St	12	WB	0	0	0	0	0		
Broadway	12	NB	0	0	-32	0	0		
Broadway	12	SB	0	-20	-273	0	0		-353
Central Park and W 61st St									
2019 (TMC-054)	13								
W 61st St	13	EB	0	-26	0	0	0		
-	13	WB	0	0	0	0	0		
Central Park	13	NB	0	0	-74	0	0		
Central Park	13	SB	0	0	0	0	0		-100
Central Park and W 81st St									
2019 (TMC-055)	14								
W 81st St	14	EB	0	-1	-25	-2	0		
W 79th St Transverse	14	WB	0	-17	-47	-26	0		
Central Park	14	NB	0	-1	-2	-6	0		
Central Park	14	SB	0	-10	-29	-5	0		-171
Central Park West and W 66th St									
2019 (TMC-056)	15								
W 66th St	15	EB	0	0	0	0	0		
W 66th St	15	WB	0	-35	-67	-42	0		
Central Park West	15	NB	0	-1	-15	0	0		
Central Park West	15	SB	0	0	-87	-1	0		-248
Central Park West and W 65th St									
2019 (TMC-057)	16								
W 65th St	16	EB	0	-2	-24	-1	0		
W 65th St	16	WB	0	0	0	0	0		
Central Park West	16	NB	0	0	-14	-3	0		
Central Park West	16	SB	0	-47	-75	0	0		-166

CBD Tolling
9A - Traffic Flowmap
AM With Action



- Legend:**
-  - Intersection (2019 Collected Data)
 -  - Intersection (Uncollected Data)
 -  - ATR Volume
 -  - Approach Volume

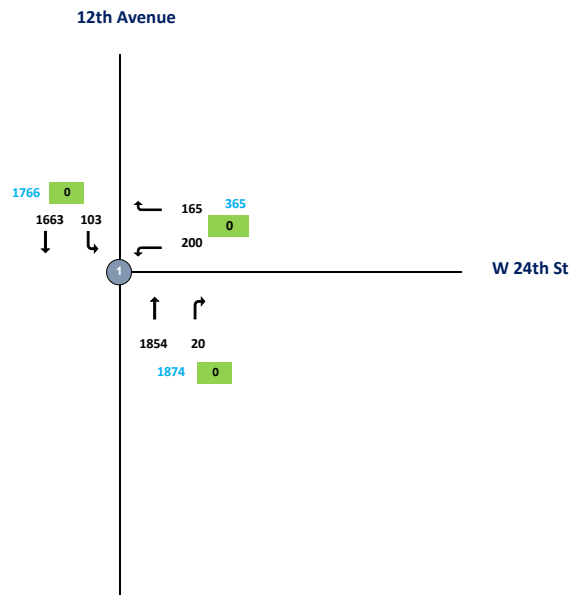

9A

8:00 AM

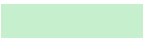

Intersection	Node	Approach	Total Vehicles					
			Inbound/Outbound					
			AM Peak Hour					
			L2	L	T	R	R2	Total
12th Ave & 24th Street 2019 (TMC-065)	1							
24th Street	1	EB	0	0	0	0	0	
24th Street	1	WB	0	200	0	165	0	
12th Ave	1	NB	0	0	1854	20	0	
12th Ave	1	SB	0	103	1663	0	0	4005

CBD Tolling
9A - Traffic Flowmap
MD With-Action



- Legend:**
- Intersection (2019 Collected Data)
 - Intersection (Uncollected Data)
 - 100 - ATR Volume
 - 100 - Approach Volume

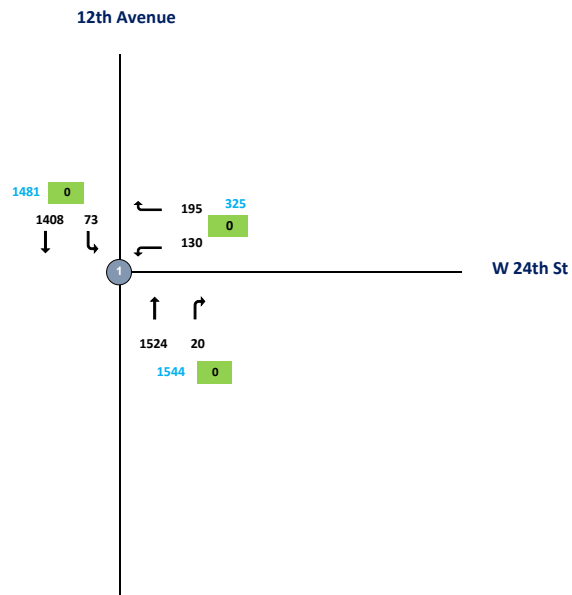

9A

1:00 PM

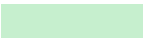

Intersection	Node	Approach	Total Vehicles					
			Inbound/Outbound					
			AM Peak Hour					
			L2	L	T	R	R2	Total
12th Ave & 24th Street 2019 (TMC-065)	1							
24th Street	1	EB	0	0	0	0	0	
24th Street	1	WB	0	130	0	195	0	
12th Ave	1	NB	0	0	1524	20	0	
12th Ave	1	SB	0	73	1408	0	0	3350

CBD Tolling
9A - Traffic Flowmap
PM With Action



- Legend:**
- Intersection (2019 Collected Data)
 - Intersection (Uncollected Data)
 - ATR Volume
 - Approach Volume

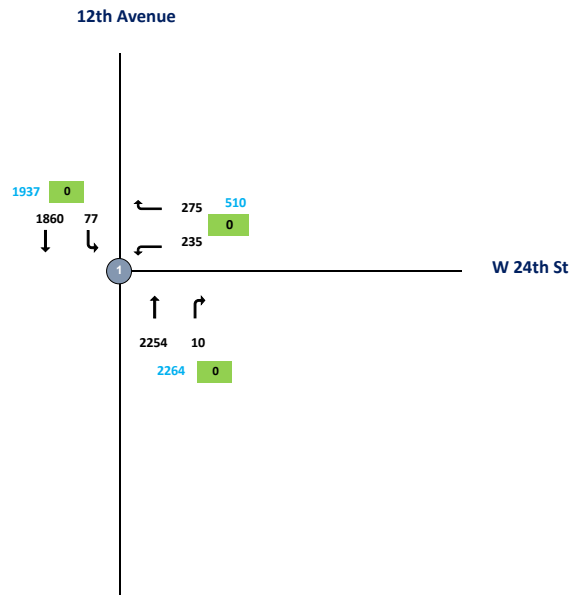

9A		5:00 PM							
Intersection	Node	Approach	Total Vehicles						
			Inbound/Outbound						
			PM Peak Hour						
			L2	L	T	R	R2	Total	
12th Ave & 24th Street 2019 (TMC-065)	1								
24th Street	1	EB	0	0	0	0	0		
24th Street	1	WB	0	235	0	275	0		
12th Ave	1	NB	0	0	2254	10	0		
12th Ave	1	SB	0	77	1860	0	0	4711	

CBD Tolling
9A - Traffic Flowmap
LN With-Action



- Legend:**
- Intersection (2019 Collected Data)
 - Intersection (Uncollected Data)
 - 100** - ATR Volume
 - 100 - Approach Volume

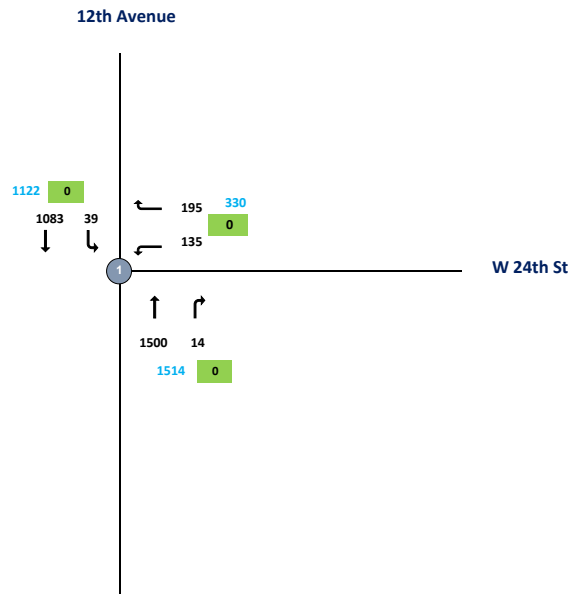

9A

9:00 PM

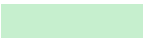

Intersection	Node	Approach	Total Vehicles					
			Inbound/Outbound					
			LN Peak Hour					
			L2	L	T	R	R2	Total
12th Ave & 24th Street 2019 (TMC-065)	1							
24th Street	1	EB	0	0	0	0	0	
24th Street	1	WB	0	135	0	195	0	
12th Ave	1	NB	0	0	1500	14	0	
12th Ave	1	SB	0	39	1083	0	0	2966

CBD Tolling
Dumbo #1- Traffic Flowmap
AM With Action



- Legend:**
- 1 - Intersection (2019 Collected Data)
 - 7 - Intersection (Uncollected Data)
 - 100 - ATR Volume
 - 100 - Approach Volume

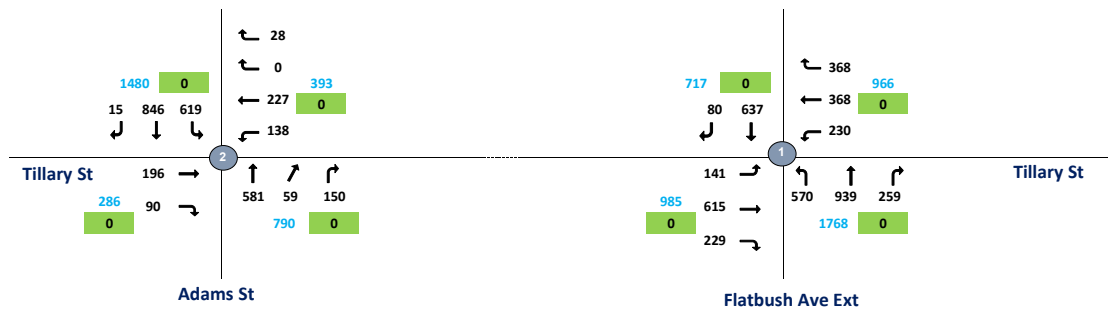

CBD Tolling
Dumbo #2 - Traffic Flowmap
AM With Action



- Legend:**
- 1 - Intersection (2019 Collected Data)
 - 7 - Intersection (Uncollected Data)
 - 100 - ATR Volume
 - 100 - Approach Volume

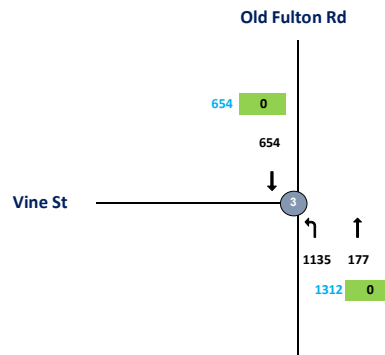

DUMBO

8:00:00 AM

Intersection	Node	Approach	Total Vehicles						
			Inbound/Outbound					Total	
			AM Peak Hour						
			L2	L	T	R	R2		
Tillary St & Flatbush Ave ext 2019 (TMC-007)	1								
Tillary St	1	EB	0	141	615	229	0		
Tillary St	1	WB	0	230	368	368	0		
Flatbush Ave ext	1	NB	0	570	939	259	0		
Flatbush Ave ext	1	SB	0	0	637	80	0		4436
Tillary St & Adams St 2019 (TMC-008)	2								
Tillary St	2	EB	0	0	196	90	0		
Tillary St	2	WB	0	138	227	0	28		
Adams St	2	NB	0	0	581	59	150		
Adams St	2	SB	0	619	846	15	0		2949
Vine St & Old Fulton Rd 2019 (TMC-009)	3								
Vine St	3	EB	0	0	0	0	0		
Vine St	3	WB	0	0	0	0	0		
Old Fulton Rd	3	NB	0	1135	177	0	0		
Old Fulton Rd	3	SB	0	0	654	0	0		1966

CBD Tolling
Dumbo - Traffic Flowmap
MD With Action



- Legend:**
- 1 - Intersection (2019 Collected Data)
 - 7 - Intersection (Uncollected Data)
 - 100 - ATR Volume
 - 100 - Approach Volume

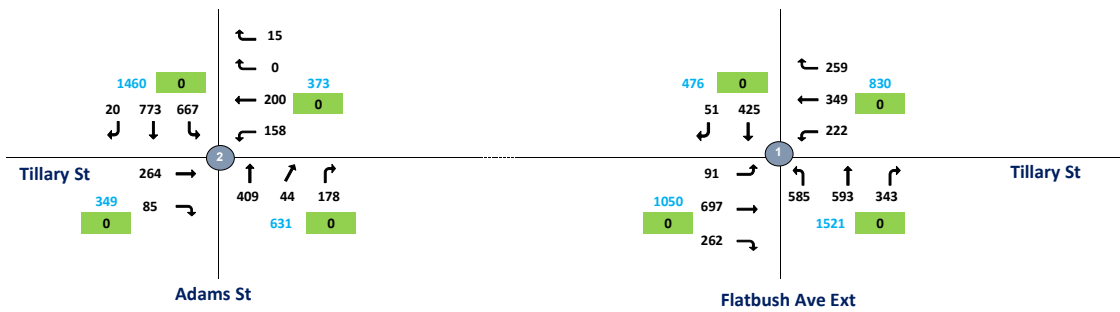

CBD Tolling
Dumbo #2 - Traffic Flowmap
MD With Action



- Legend:**
- 1 - Intersection (2019 Collected Data)
 - 7 - Intersection (Uncollected Data)
 - 100 - ATR Volume
 - 100 - Approach Volume

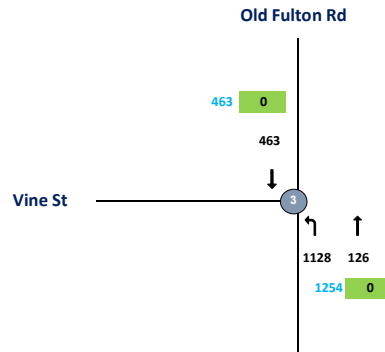

DUMBO

1:00:00 PM

Intersection	Node	Approach	Total Vehicles					Total
			Inbound/Outbound					
			MD Peak Hour					
L2	L	T	R	R2				
2019 (TMC-007) Tillary St & Flatbush Ave ext	1							
Tillary St	1	EB	0	91	697	262	0	
Tillary St	1	WB	0	222	349	259	0	
Flatbush Ave ext	1	NB	0	585	593	343	0	
Flatbush Ave ext	1	SB	0	0	425	51	0	
							3877	
2019 (TMC-008) Tillary St & Adams St	2							
Tillary St	2	EB	0	0	264	85	0	
Tillary St	2	WB	0	158	200	0	15	
Adams St	2	NB	0	0	409	44	178	
Adams St	2	SB	0	667	773	20	0	
							2813	
2019 (TMC-009) Vine St & Old Fulton Rd	3							
Vine St	3	EB	0	0	0	0	0	
Vine St	3	WB	0	0	0	0	0	
Old Fulton Rd	3	NB	0	1128	126	0	0	
Old Fulton Rd	3	SB	0	0	463	0	0	
							1717	

CBD Tolling
Dumbo - Traffic Flowmap
PM With Action



- Legend:**
- 1 - Intersection (2019 Collected Data)
 - 7 - Intersection (Uncollected Data)
 - 100 - ATR Volume
 - 100 - Approach Volume

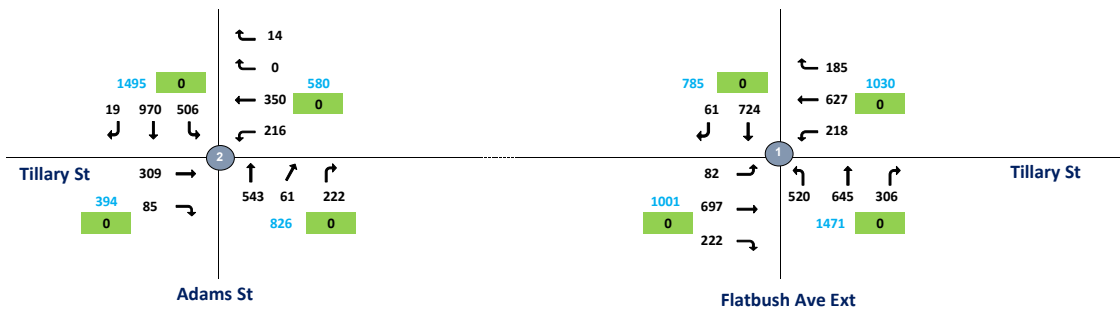

CBD Tolling
Dumbo #2 - Traffic Flowmap
PM With Action



- Legend:**
- 1 - Intersection (2019 Collected Data)
 - 7 - Intersection (Uncollected Data)
 - 100 - ATR Volume
 - 100 - Approach Volume

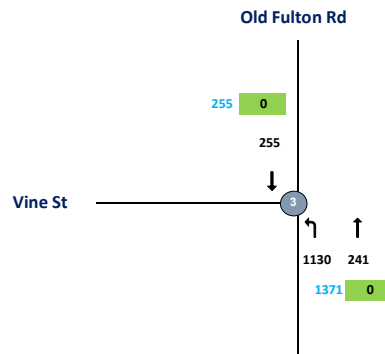

DUMBO

5:00:00 PM

Intersection	Node	Approach	Total Vehicles					Total
			Inbound/Outbound					
			L2	L	T	R	R2	
2019 (TMC-007) Tillary St & Flatbush Ave ext	1							
Tillary St	1	EB	0	82	697	222	0	
Tillary St	1	WB	0	218	627	185	0	
Flatbush Ave ext	1	NB	0	520	645	306	0	
Flatbush Ave ext	1	SB	0	0	724	61	0	4287
2019 (TMC-008) Tillary St & Adams St	2							
Tillary St	2	EB	0	0	309	85	0	
Tillary St	2	WB	0	216	350	0	14	
Adams St	2	NB	0	0	543	61	222	
Adams St	2	SB	0	506	970	19	0	3295
2019 (TMC-009) Vine St & Old Fulton Rd	3							
Vine St	3	EB	0	0	0	0	0	
Vine St	3	WB	0	0	0	0	0	
Old Fulton Rd	3	NB	0	1130	241	0	0	
Old Fulton Rd	3	SB	0	0	255	0	0	1626

CBD Tolling
Dumbo - Traffic Flowmap
LN With Action



- Legend:**
- 1 - Intersection (2019 Collected Data)
 - 7 - Intersection (Uncollected Data)
 - 100 - ATR Volume
 - 100 - Approach Volume

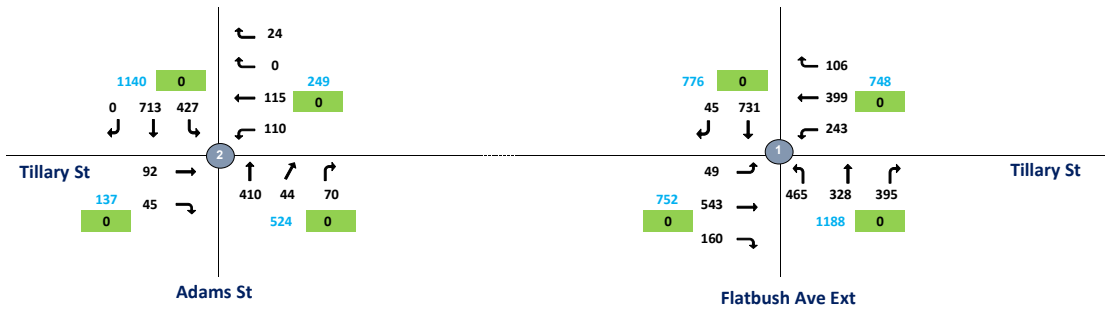

CBD Tolling
Dumbo #2 - Traffic Flowmap
LN With Action



- Legend:**
- 1 - Intersection (2019 Collected Data)
 - 7 - Intersection (Uncollected Data)
 - 100 - ATR Volume
 - 100 - Approach Volume

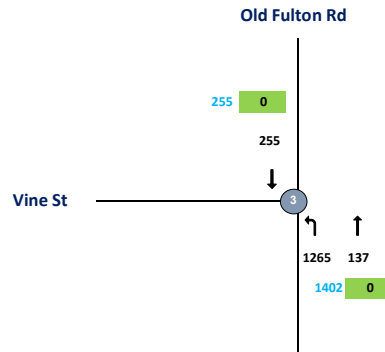

DUMBO

9:00:00 PM

Intersection	Node	Approach	Total Vehicles					Total
			Inbound/Outbound					
			LN Peak Hour					
			L2	L	T	R	R2	
Tillary St & Flatbush Ave ext 2019 (TMC-007)	1							
Tillary St	1	EB	0	49	543	160	0	
Tillary St	1	WB	0	243	399	106	0	
Flatbush Ave ext	1	NB	0	465	328	395	0	
Flatbush Ave ext	1	SB	0	0	731	45	0	3464
Tillary St & Adams St 2019 (TMC-008)	2							
Tillary St	2	EB	0	0	92	45	0	
Tillary St	2	WB	0	110	115	0	24	
Adams St	2	NB	0	0	410	44	70	
Adams St	2	SB	0	427	713	0	0	2050
Vine St & Old Fulton Rd 2019 (TMC-009)	3							
Vine St	3	EB	0	0	0	0	0	
Vine St	3	WB	0	0	0	0	0	
Old Fulton Rd	3	NB	0	1265	137	0	0	
Old Fulton Rd	3	SB	0	0	255	0	0	1657

CBD Tolling
LIC - Traffic Flowmap #1
AM With Action



- Legend:**
- 1 - Intersection (2019 Collected Data)
 - ? - Intersection (Uncollected Data)
 - 100 - ATR Volume
 - 100 - Approach Volume

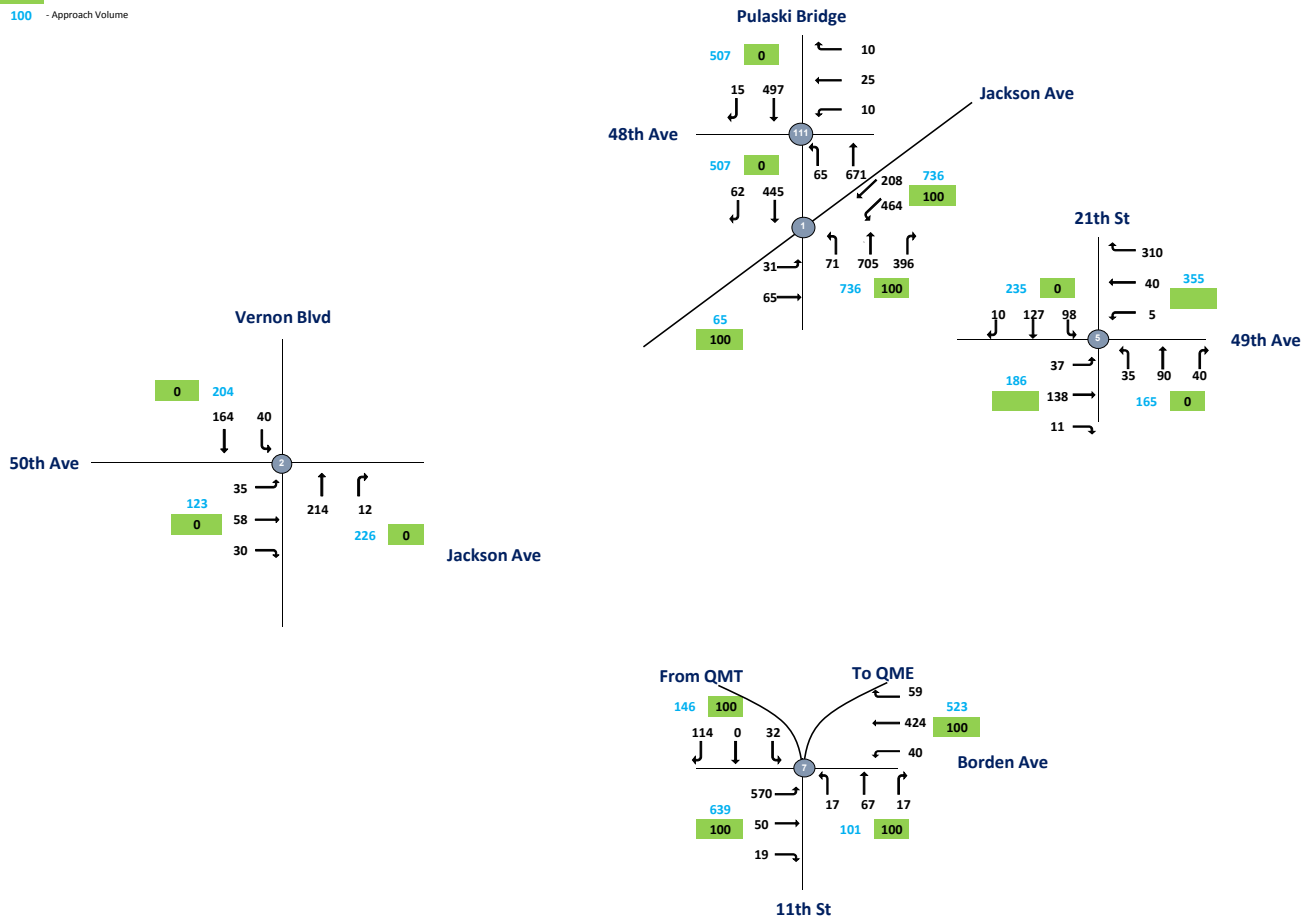

CBD Tolling
LIC - Traffic Flowmap #2
AM With Action



- Legend:**
- Intersection (2019 Collected Data)
 - Intersection (Uncollected Data)
 - 100 - ATR Volume
 - 100 - Approach Volume

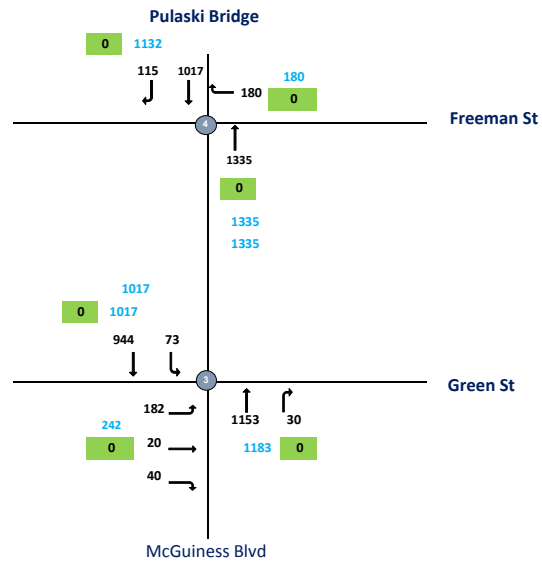

CBD Tolling
LIC - Traffic Flowmap #3
AM With Action



- Legend:**
- Intersection (2019 Collected Data)
 - Intersection (Uncollected Data)
 - 100 - ATR Volume
 - 100 - Approach Volume

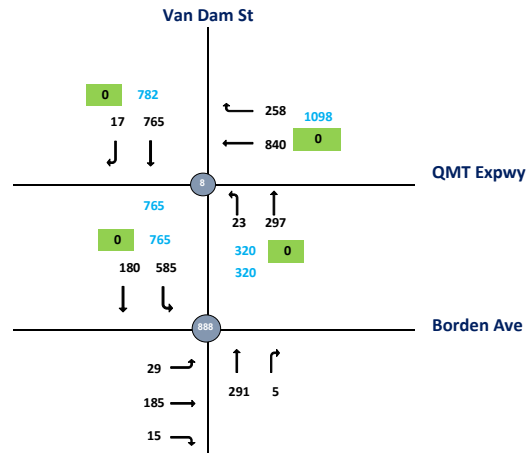

CBD Tolling
LIC - Traffic Flowmap #4
AM With Action



- Legend:**
- 1 - Intersection (2019 Collected Data)
 - 7 - Intersection (Uncollected Data)
 - 100 - ATR Volume
 - 100 - Approach Volume

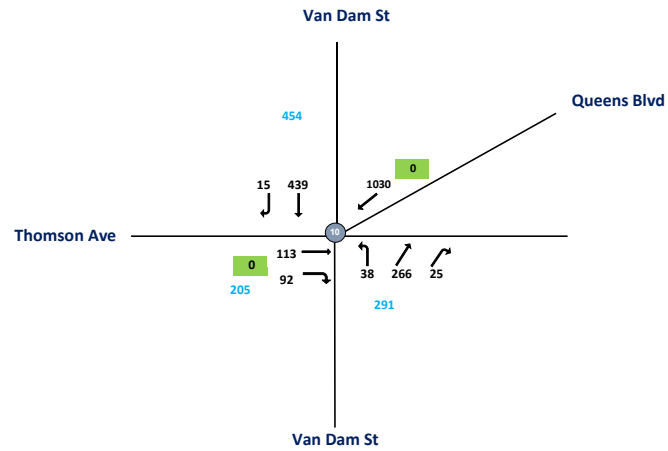
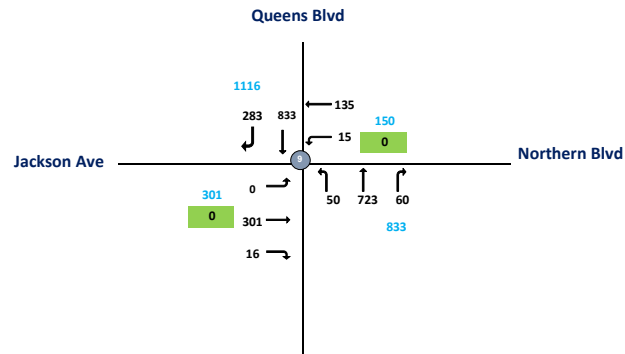

CBD Tolling
LIC - Traffic Flowmap #5
AM With Action



- Legend:**
- Intersection (2019 Collected Data)
 - Intersection (Uncollected Data)
 - 100 - ATR Volume
 - 100 - Approach Volume

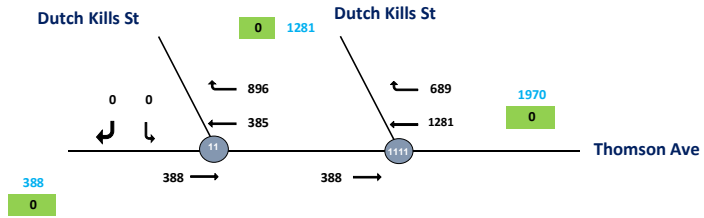

CBD Tolling
LIC - Traffic Flowmap #6
AM With Action



- Legend:**
- Intersection (2019 Collected Data)
 - Intersection (Uncollected Data)
 - 100 - ATR Volume
 - 100 - Approach Volume

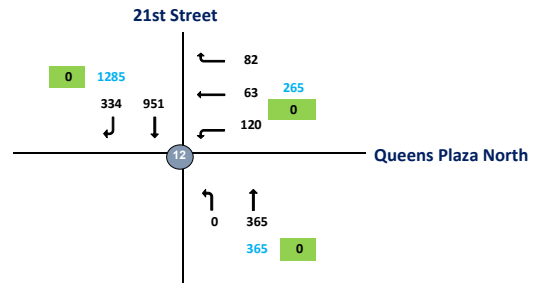

LIC

7:00:00 AM

Intersection	Node	Approach	Total Vehicles					
			Inbound/Outbound					Total
			AM Peak Hour					
L2	L	T	R	R2				
11th St / Pulaski Bdrge & Jackson Ave 2017 --> 2019 (LIC_1_TMC-6A)	1							
Pulaski Bridge / 11th St	1	EB	0	31	65	0	0	
Pulaski Bridge / 11th St	1	WB	0	464	208	0	0	
Jackson Ave	1	NB	0	71	705	396	0	
Jackson Ave	1	SB	0	0	445	62	0	2447
11th St / 48th St 2017 --> 2019 (LIC_1_TMC-6A)	111							
11th St	111	EB	0	0	0	0	0	
11th St	111	WB	0	10	25	10	0	
48th St	111	NB	0	65	671	0	0	
48th St	111	SB	0	0	497	15	0	1293
Vernon Blvd & 50th Ave 2019 (TMC-001)	2							
50th Ave	2	EB	0	35	58	30	0	
50th Ave	2	WB	0	0	0	0	0	
Vernon Blvd	2	NB	0	0	214	12	0	
Vernon Blvd	2	SB	0	40	164	0	0	553
Pulsaki Bridge & Green St 2019 (TMC-002)	3							
Green St	3	EB	0	182	20	40	0	
Green St	3	WB	0	0	0	0	0	
Pulsaki Bridge	3	NB	0	0	1153	30	0	
Pulsaki Btridge	3	SB	0	73	944	0	0	2442
Pulsaki Bridge & Freeman St 2019 (TMC-003)	4							
Freeman St	4	EB	0	0	0	0	0	
Freeman St	4	WB	0	0	0	180	0	
Pulsaki Bridge	4	NB	0	0	1335	0	0	
Pulsaki Btridge	4	SB	0	0	1017	115	0	2647
49th Ave & 21st St 2017 --> 2019 (LIC_5_TMC-6C)	5							
49th Ave	5	EB	0	37	138	11	0	
49th Ave	5	WB	0	5	40	310	0	
21th Ave	5	NB	0	35	90	40	0	
21th Ave	5	SB	0	98	127	10	0	941
Borden Ave & 11th Street 2018 -- 2019 (LIC_7_TMC-6D)	7							
Borden Ave	7	EB	0	570	50	19	0	
Borden Ave	7	WB	0	40	424	59	0	
11th St	7	NB	0	17	67	17	0	
11th St	7	SB	0	32	0	114	0	1409

Van Dam St & QMT Expwy (North) 2019 (TMC-004A)	8								
QMT Expwy	8	EB	0	0	0	0	0		
QMT Expwy	8	WB	0	0	840	258	0		
Van Dam St	8	NB	0	23	297	0	0		
Van Dam St	8	SB	0	0	765	17	0		2200
Van Dam St & QMT Expwy (South) 2019 (TMC-004B)	888								
QMT Expwy	888	EB	0	29	185	15	0		
QMT Expwy	888	WB	0	0	0	0	0		
Van Dam St	888	NB	0	0	291	5	0		
Van Dam St	888	SB	0	585	180	0	0		1290
Queens Blvd & Jackson Ave (Mainline) 2018 --> 2019 (LIC_9A_TMC-6E)	9								
Queens Blvd	9	EB	0	0	833	283	0		
Queens Blvd	9	WB	0	50	723	60	0		
Jackson Ave	9	NB	0	0	301	16	0		
Jackson Ave	9	SB	0	15	135	0	0		2416
Queens Blvd & Jackson Ave (Service Rd) 2018 --> 2019 (LIC_9A_TMC-6E)	9A								
Queens Blvd	9A	EB	0	0	35	355	0		
Queens Blvd	9A	WB	0	0	0	0	0		
Jackson Ave	9A	NB	0	0	0	0	0		
Jackson Ave	9A	SB	0	0	0	0	0		390
Thompson Ave & Queens Blvd 2018 --> 2019 (LIC_10_TMC-6G)	10								
Queens Blvd	10	EB	0	0	0	113	92		
Queens Blvd	10	WB	0	0	1030	0	0		
Thompson Ave	10	NB	0	38	266	0	25		
Thompson Ave	10	SB	0	0	439	15	0		2018
Dutch Kills St & Thomson Ave (#1) 2019 (TMC-005)	11								
Thomson Ave	11	EB	0	0	388	0	0		
Thomson Ave	11	WB	0	0	385	896	0		
Dutch Kills St	11	NB	0	0	0	0	0		
Dutch Kills St	11	SB	0	0	0	0	0		1669
Dutch Kills St & Thomson Ave (#2) 2019 (TMC-005)	1111								
Thomson Ave	1111	EB	0	0	388	0	0		
Thomson Ave	1111	WB	0	0	1281	689	0		
Dutch Kills St	1111	NB	0	0	0	0	0		
Dutch Kills St	1111	SB	0	0	0	0	0		2358
21st Street & Queens Plaza North 2019 (TMC-006)	12								
Queens Plaza North	12	EB	0	0	0	0	0		
Queens Plaza North	12	WB	0	120	63	82	0		
21st Street	12	NB	0	0	365	0	0		
21st Street	12	SB	0	0	951	334	0		1915

CBD Tolling
LIC - Traffic Flowmap #1
MD With Action



- Legend:**
- 1 - Intersection (2019 Collected Data)
 - 7 - Intersection (Uncollected Data)
 - 100 - ATR Volume
 - 100 - Approach Volume

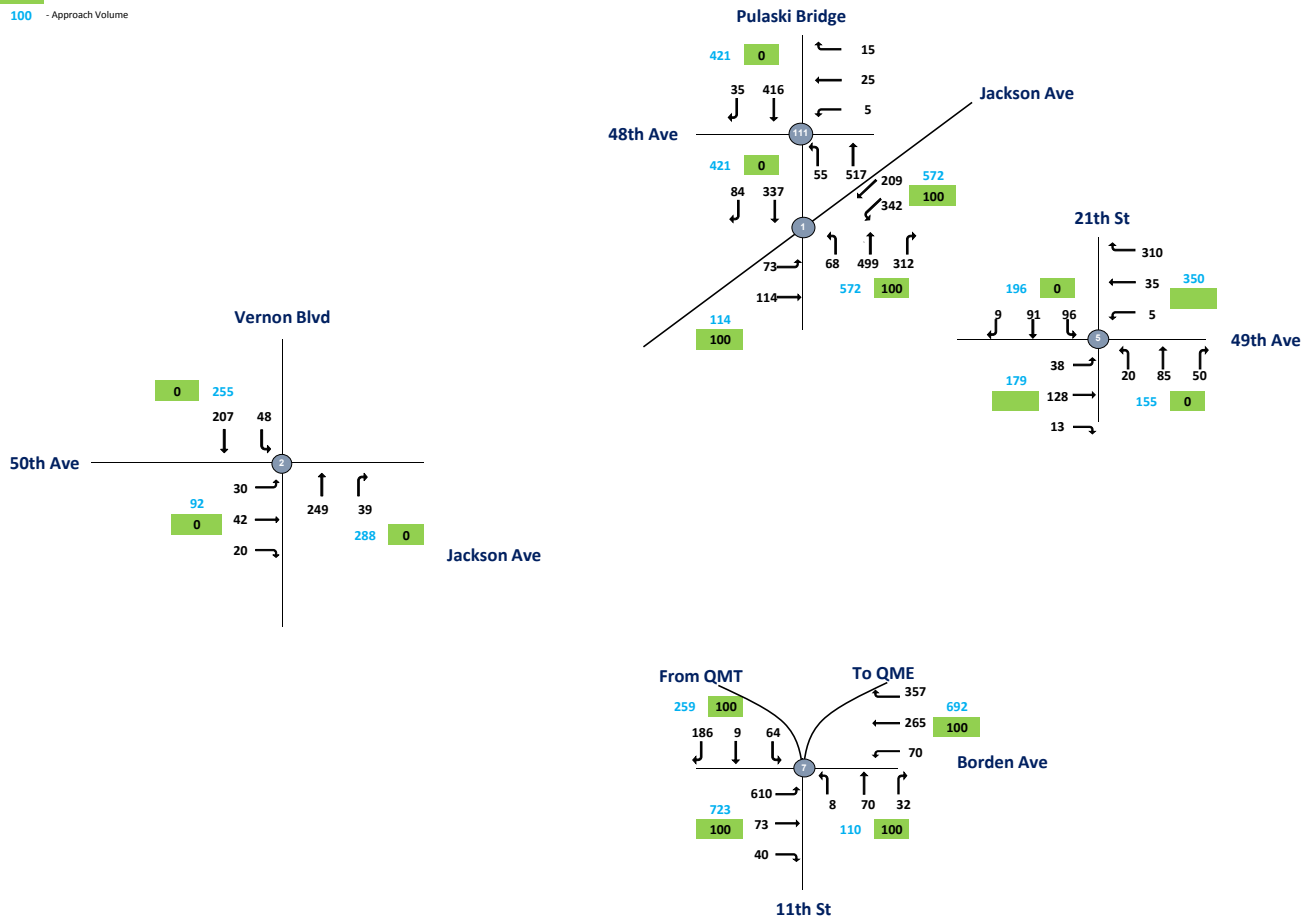

CBD Tolling
LIC - Traffic Flowmap #2
MD With Action



- Legend:**
- Intersection (2019 Collected Data)
 - Intersection (Uncollected Data)
 - 100 - ATR Volume
 - 100 - Approach Volume

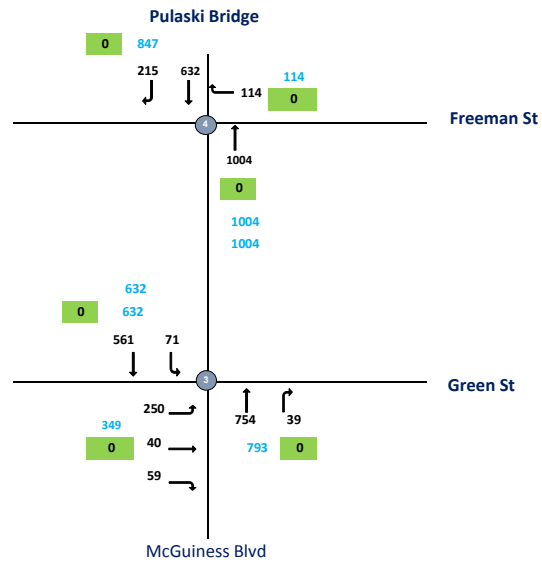

CBD Tolling
LIC - Traffic Flowmap #3
MD With Action



- Legend:**
- Intersection (2019 Collected Data)
 - Intersection (Uncollected Data)
 - 100 - ATR Volume
 - 100 - Approach Volume

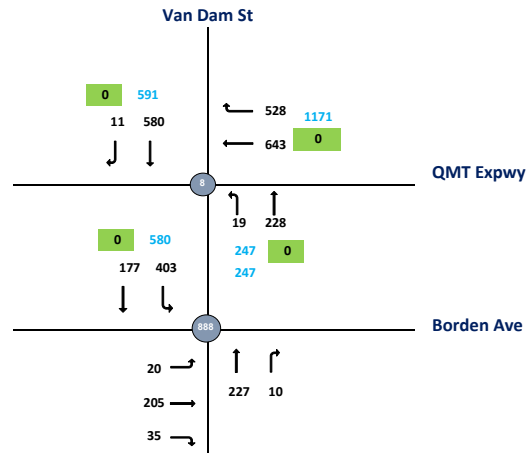

CBD Tolling
LIC - Traffic Flowmap #4
MD With Action



- Legend:**
- 1 - Intersection (2019 Collected Data)
 - 7 - Intersection (Uncollected Data)
 - 100 - ATR Volume
 - 100 - Approach Volume

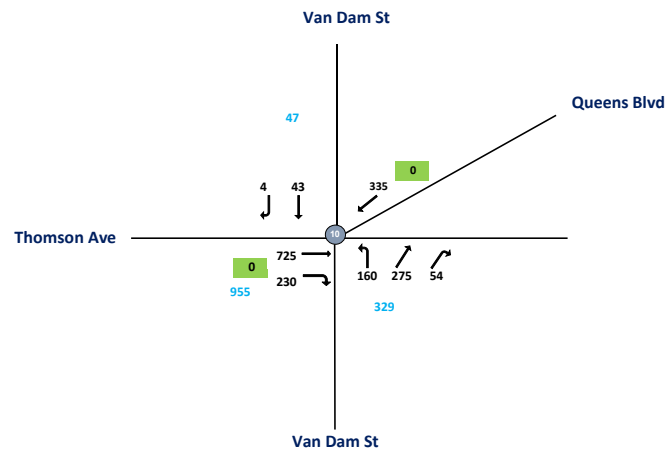
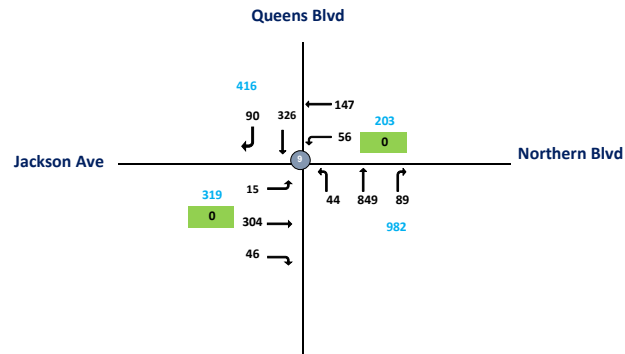

CBD Tolling
LIC - Traffic Flowmap #5
MD With Action



- Legend:**
- Intersection (2019 Collected Data)
 - Intersection (Uncollected Data)
 - 100 - ATR Volume
 - 100 - Approach Volume

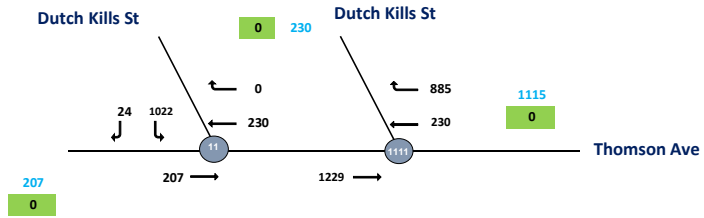

CBD Tolling
LIC - Traffic Flowmap #6
MD With Action



- Legend:**
- Intersection (2019 Collected Data)
 - Intersection (Uncollected Data)
 - 100 - ATR Volume
 - 100 - Approach Volume

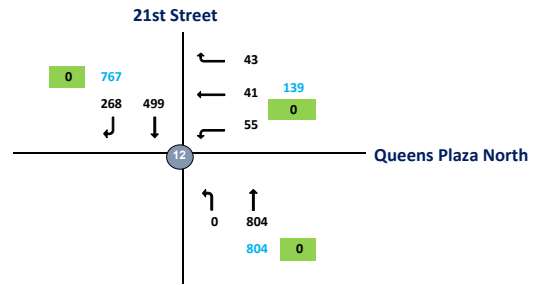

Intersection	Node	Approach	Total Vehicles						
			Inbound/Outbound					Total	
			MD Peak Hour						
			L2	L	T	R	R2		
11th St / Pulaski Brdge & Jackson Ave 2017 --> 2019 (LIC_1_TMC-6A)	1								
Pulaski Bridge / 11th St	1	EB	0	73	114	0	0		
Pulaski Bridge / 11th St	1	WB	0	342	209	0	0		
Jackson Ave	1	NB	0	68	499	312	0		
Jackson Ave	1	SB	0	0	337	84	0		2038
11th St / 48th St 2017 --> 2019 (LIC_1_TMC-6A)	111								
11th St	111	EB	0	0	0	0	0		
11th St	111	WB	0	5	25	15	0		
48th St	111	NB	0	55	517	0	0		
48th St	111	SB	0	0	416	35	0		1068
Vernon Blvd & 50th Ave 2019 (TMC-001)	2								
50th Ave	2	EB	0	30	42	20	0		
50th Ave	2	WB	0	0	0	0	0		
Vernon Blvd	2	NB	0	0	249	39	0		
Vernon Blvd	2	SB	0	48	207	0	0		635
Pulsaki Bridge & Green St 2019 (TMC-002)	3								
Green St	3	EB	0	250	40	59	0		
Green St	3	WB	0	0	0	0	0		
Pulsaki Bridge	3	NB	0	0	754	39	0		
Pulsaki Btridge	3	SB	0	71	561	0	0		1774
Pulsaki Bridge & Freeman St 2019 (TMC-003)	4								
Freeman St	4	EB	0	0	0	0	0		
Freeman St	4	WB	0	0	0	114	0		
Pulsaki Bridge	4	NB	0	0	1004	0	0		
Pulsaki Btridge	4	SB	0	0	632	215	0		1965
49th Ave & 21st St 2017 --> 2019 (LIC_5_TMC-6C)	5								
49th Ave	5	EB	0	38	128	13	0		
49th Ave	5	WB	0	5	35	310	0		
21th Ave	5	NB	0	20	85	50	0		
21th Ave	5	SB	0	96	91	9	0		880
Borden Ave & 11th Street 2018 -- 2019 (LIC_7_TMC-6D)	7								
Borden Ave	7	EB	0	610	73	40	0		
Borden Ave	7	WB	0	70	265	357	0		
11th St	7	NB	0	8	70	32	0		
11th St	7	SB	0	64	9	186	0		1784

Van Dam St & QMT Expwy (North) 2019 (TMC-004A)	8								
QMT Expwy	8	EB	0	0	0	0	0		
QMT Expwy	8	WB	0	0	643	528	0		
Van Dam St	8	NB	0	19	228	0	0		
Van Dam St	8	SB	0	0	580	11	0		2009
Van Dam St & QMT Expwy (South) 2019 (TMC-004B)	888								
QMT Expwy	888	EB	0	20	205	35	0		
QMT Expwy	888	WB	0	0	0	0	0		
Van Dam St	888	NB	0	0	227	10	0		
Van Dam St	888	SB	0	403	177	0	0		1077
Queens Blvd & Jackson Ave (Mainline) 2018 --> 2019 (LIC_9A_TMC-6E)	9								
Queens Blvd	9	EB	0	0	326	90	0		
Queens Blvd	9	WB	0	44	849	89	0		
Jackson Ave	9	NB	0	15	304	46	0		
Jackson Ave	9	SB	0	56	147	0	0		1966
Queens Blvd & Jackson Ave (Service Rd) 2018 --> 2019 (LIC_9A_TMC-6E)	9A								
Queens Blvd	9A	EB	0	0	45	260	0		
Queens Blvd	9A	WB	0	0	0	0	0		
Jackson Ave	9A	NB	0	0	0	0	0		
Jackson Ave	9A	SB	0	0	0	0	0		305
Thompson Ave & Queens Blvd 2018 --> 2019 (LIC_10_TMC-6G)	10								
Queens Blvd	10	EB	0	0	0	725	230		
Queens Blvd	10	WB	0	0	335	0	0		
Thompson Ave	10	NB	0	160	275	0	54		
Thompson Ave	10	SB	0	0	43	4	0		1826
Dutch Kills St & Thomson Ave (#1) 2019 (TMC-005)	11								
Thomson Ave	11	EB	0	0	207	0	0		
Thomson Ave	11	WB	0	0	230	0	0		
Dutch Kills St	11	NB	0	0	0	0	0		
Dutch Kills St	11	SB	0	1022	0	24	0		1483
Dutch Kills St & Thomson Ave (#2) 2019 (TMC-005)	1111								
Thomson Ave	1111	EB	0	0	1229	0	0		
Thomson Ave	1111	WB	0	0	230	885	0		
Dutch Kills St	1111	NB	0	0	0	0	0		
Dutch Kills St	1111	SB	0	0	0	0	0		2344
21st Street & Queens Plaza North 2019 (TMC-006)	12								
Queens Plaza North	12	EB	0	0	0	0	0		
Queens Plaza North	12	WB	0	55	41	43	0		
21st Street	12	NB	0	0	804	0	0		
21st Street	12	SB	0	0	499	268	0		1710

CBD Tolling
LIC - Traffic Flowmap #1
PM With Action



- Legend:**
- 1 - Intersection (2019 Collected Data)
 - 7 - Intersection (Uncollected Data)
 - 100 - ATR Volume
 - 100 - Approach Volume

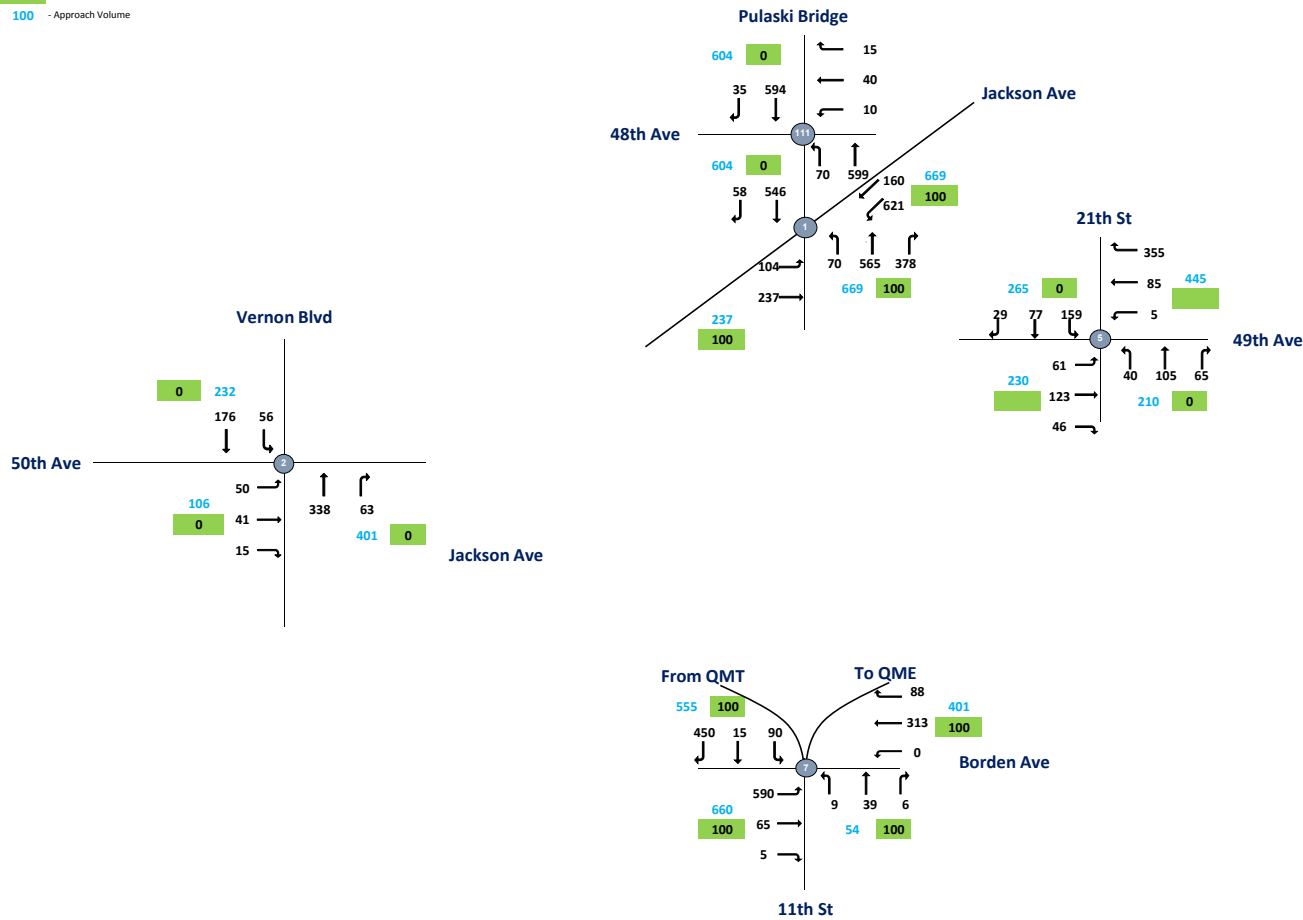

CBD Tolling
LIC - Traffic Flowmap #2
PM With Action



- Legend:**
- Intersection (2019 Collected Data)
 - Intersection (Uncollected Data)
 - 100 - ATR Volume
 - 100 - Approach Volume

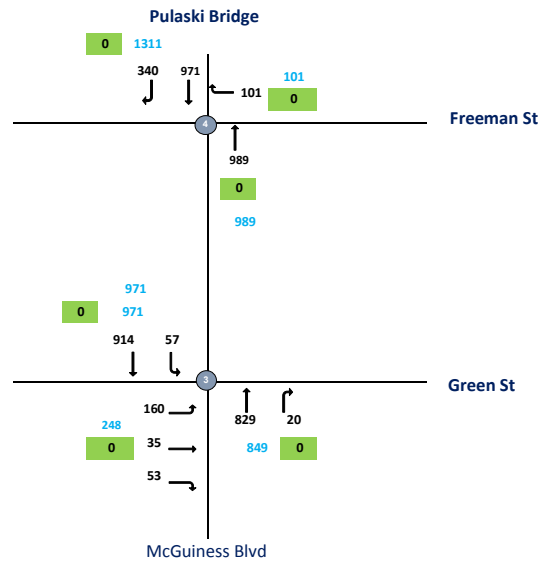

CBD Tolling
LIC - Traffic Flowmap #3
PM With Action



- Legend:**
- Intersection (2019 Collected Data)
 - Intersection (Uncollected Data)
 - 100 - ATR Volume
 - 100 - Approach Volume

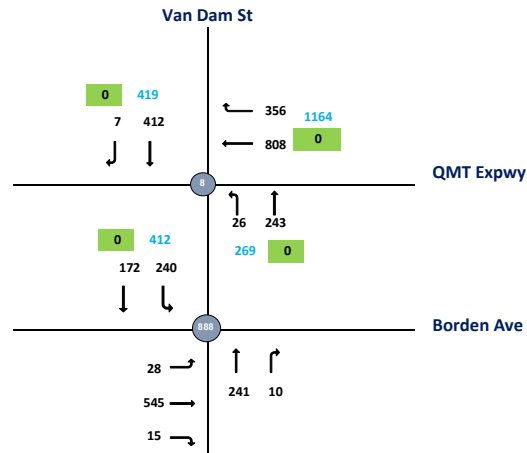

CBD Tolling
LIC - Traffic Flowmap #4
PM With Action



- Legend:**
- 1 - Intersection (2019 Collected Data)
 - 7 - Intersection (Uncollected Data)
 - 100 - ATR Volume
 - Approach Volume

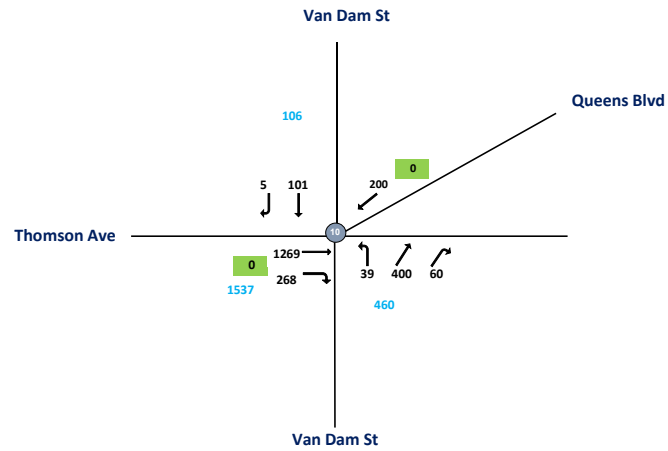
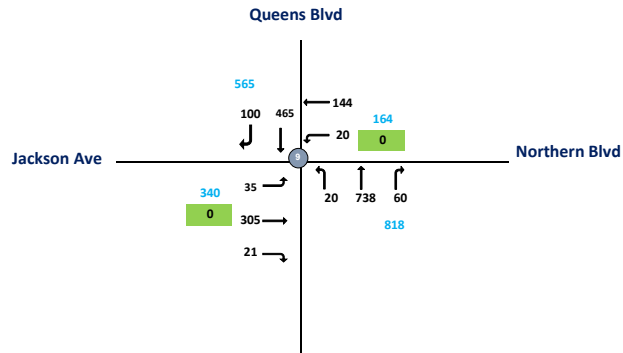

CBD Tolling
LIC - Traffic Flowmap #5
PM With Action



- Legend:**
- Intersection (2019 Collected Data)
 - Intersection (Uncollected Data)
 - 100 - ATR Volume
 - 100 - Approach Volume

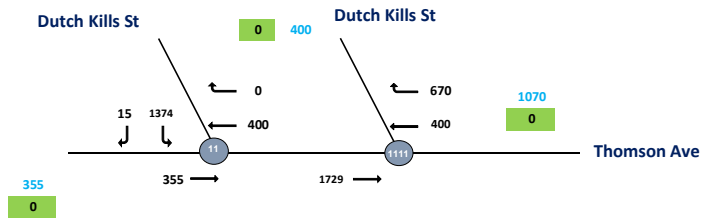

CBD Tolling
LIC - Traffic Flowmap #6
PM With Action



- Legend:**
- Intersection (2019 Collected Data)
 - Intersection (Uncollected Data)
 - 100 - ATR Volume
 - 100 - Approach Volume

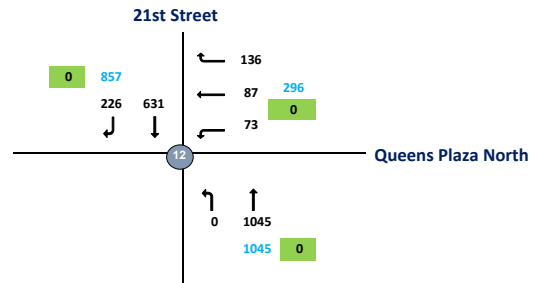

LIC

9:00:00 PM

Intersection	Node	Approach	Total Vehicles					
			Inbound/Outbound					Total
			PM Peak Hour					
L2	L	T	R	R2				
11th St / Pulaski Brdge & Jackson Ave 2017 --> 2019 (LIC_1_TMC-6A)	1							
Pulaski Bridge / 11th St	1	EB	0	104	237	0	0	
Pulaski Bridge / 11th St	1	WB	0	621	160	0	0	
Jackson Ave	1	NB	0	70	565	378	0	
Jackson Ave	1	SB	0	0	546	58	0	2739
11th St / 48th St 2017 --> 2019 (LIC_1_TMC-6A)	111							
11th St	111	EB	0	0	0	0	0	
11th St	111	WB	0	10	40	15	0	
48th St	111	NB	0	70	599	0	0	
48th St	111	SB	0	0	594	35	0	1363
Vernon Blvd & 50th Ave 2019 (TMC-001)	2							
50th Ave	2	EB	0	50	41	15	0	
50th Ave	2	WB	0	0	0	0	0	
Vernon Blvd	2	NB	0	0	338	63	0	
Vernon Blvd	2	SB	0	56	176	0	0	739
Pulsaki Bridge & Green St 2019 (TMC-002)	3							
Green St	3	EB	0	160	35	53	0	
Green St	3	WB	0	0	0	0	0	
Pulsaki Bridge	3	NB	0	0	829	20	0	
Pulsaki Btridge	3	SB	0	57	914	0	0	2068
Pulsaki Bridge & Freeman St 2019 (TMC-003)	4							
Freeman St	4	EB	0	0	0	0	0	
Freeman St	4	WB	0	0	0	101	0	
Pulsaki Bridge	4	NB	0	0	989	0	0	
Pulsaki Btridge	4	SB	0	0	971	340	0	2401
49th Ave & 21st St 2017 --> 2019 (LIC_5_TMC-6C)	5							
49th Ave	5	EB	0	61	123	46	0	
49th Ave	5	WB	0	5	85	355	0	
21th Ave	5	NB	0	40	105	65	0	
21th Ave	5	SB	0	159	77	29	0	1150
Borden Ave & 11th Street 2018 -- 2019 (LIC_7_TMC-6D)	7							
Borden Ave	7	EB	0	590	65	5	0	
Borden Ave	7	WB	0	0	313	88	0	
11th St	7	NB	0	9	39	6	0	
11th St	7	SB	0	90	15	450	0	1670

Van Dam St & QMT Expwy (North) 2019 (TMC-004A)	8							
QMT Expwy	8	EB	0	0	0	0	0	
QMT Expwy	8	WB	0	0	808	356	0	
Van Dam St	8	NB	0	26	243	0	0	
Van Dam St	8	SB	0	0	412	7	0	1852
Van Dam St & QMT Expwy (South) 2019 (TMC-004B)	888							
QMT Expwy	888	EB	0	28	545	15	0	
QMT Expwy	888	WB	0	0	0	0	0	
Van Dam St	888	NB	0	0	241	10	0	
Van Dam St	888	SB	0	240	172	0	0	1251
Queens Blvd & Jackson Ave (Mainline) 2018 --> 2019 (LIC_9A_TMC-6E)	9							
Queens Blvd	9	EB	0	0	465	100	0	
Queens Blvd	9	WB	0	20	738	60	0	
Jackson Ave	9	NB	0	35	305	21	0	
Jackson Ave	9	SB	0	20	144	0	0	1908
Queens Blvd & Jackson Ave (Service Rd) 2018 --> 2019 (LIC_9A_TMC-6E)	9A							
Queens Blvd	9A	EB	0	0	50	270	0	
Queens Blvd	9A	WB	0	0	0	0	0	
Jackson Ave	9A	NB	0	0	0	0	0	
Jackson Ave	9A	SB	0	0	0	0	0	320
Thompson Ave & Queens Blvd 2018 --> 2019 (LIC_10_TMC-6G)	10							
Queens Blvd	10	EB	0	0	0	1269	268	
Queens Blvd	10	WB	0	0	200	0	0	
Thompson Ave	10	NB	0	39	400	0	60	
Thompson Ave	10	SB	0	0	101	5	0	2342
Dutch Kills St & Thomson Ave (#1) 2019 (TMC-005)	11							
Thomson Ave	11	EB	0	0	355	0	0	
Thomson Ave	11	WB	0	0	400	0	0	
Dutch Kills St	11	NB	0	0	0	0	0	
Dutch Kills St	11	SB	0	1374	0	15	0	2144
Dutch Kills St & Thomson Ave (#2) 2019 (TMC-005)	1111							
Thomson Ave	1111	EB	0	0	1729	0	0	
Thomson Ave	1111	WB	0	0	400	670	0	
Dutch Kills St	1111	NB	0	0	0	0	0	
Dutch Kills St	1111	SB	0	0	0	0	0	2799
21st Street & Queens Plaza North 2019 (TMC-006)	12							
Queens Plaza North	12	EB	0	0	0	0	0	
Queens Plaza North	12	WB	0	73	87	136	0	
21st Street	12	NB	0	0	1045	0	0	
21st Street	12	SB	0	0	631	226	0	2198

CBD Tolling
LM - Traffic Flowmap #1
AM With Action



- Legend:**
- 1 - Intersection (2019 Collected Data)
 - 7 - Intersection (Uncollected Data)
 - 100 - ATR Volume
 - 100 - Approach Volume

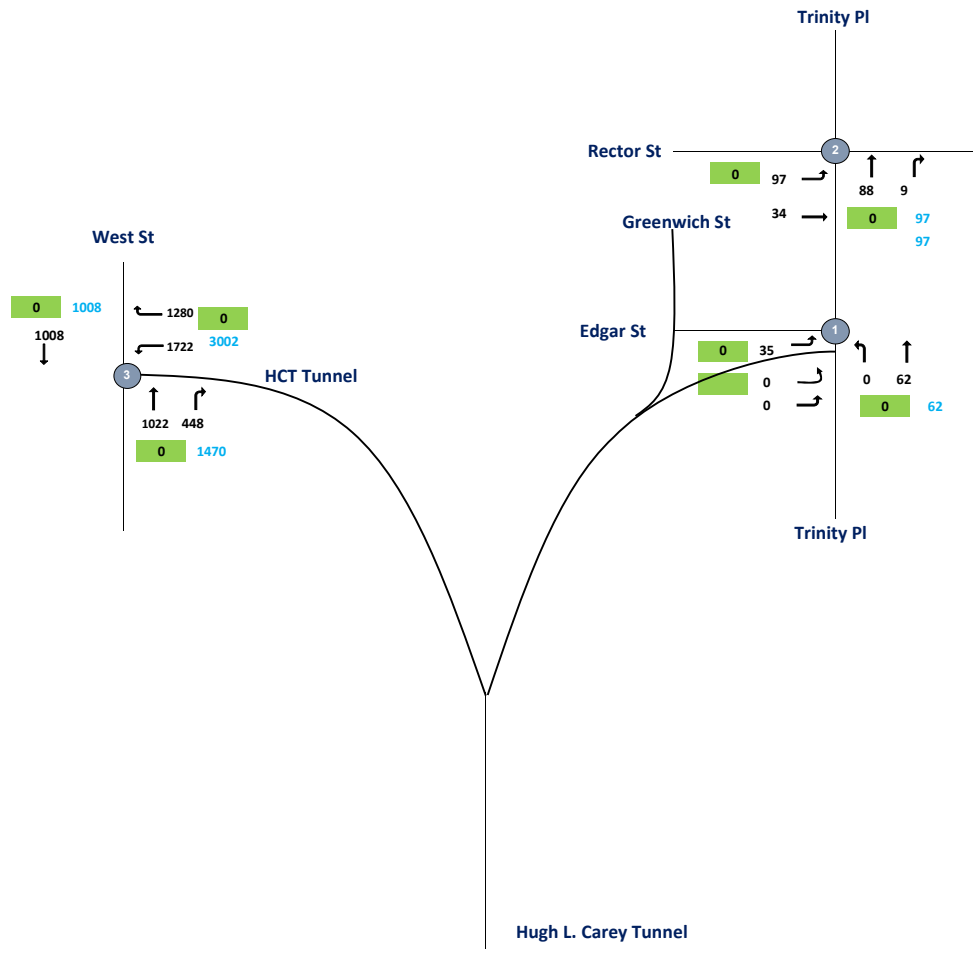

CBD Tolling
LM - Traffic Flowmap #2
AM With Action

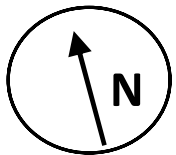

Legend:

1 - Intersection (2019 Collected Data)

7 - Intersection (Uncollected Data)

100 - ATR Volume

100 - Approach Volume

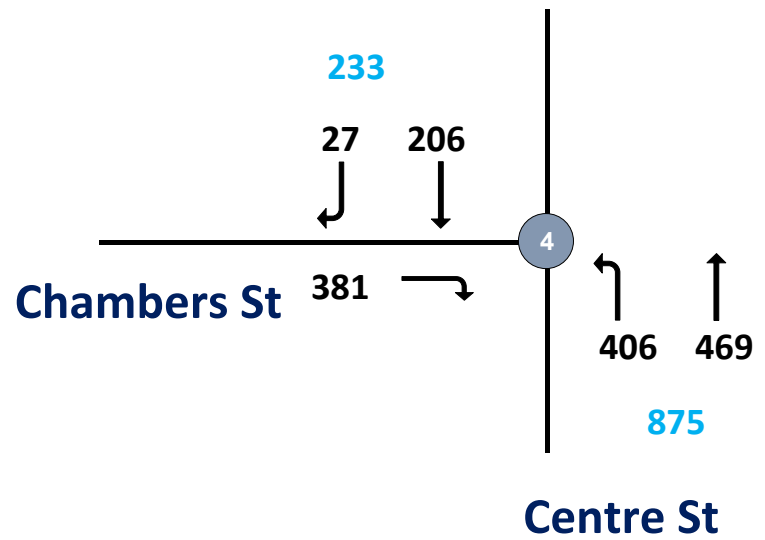

CBD Tolling
LM - Traffic Flowmap #3
AM With Action



- Legend:**
- Intersection (2019 Collected Data)
 - Intersection (Uncollected Data)
 - 100 - ATR Volume
 - 100 - Approach Volume

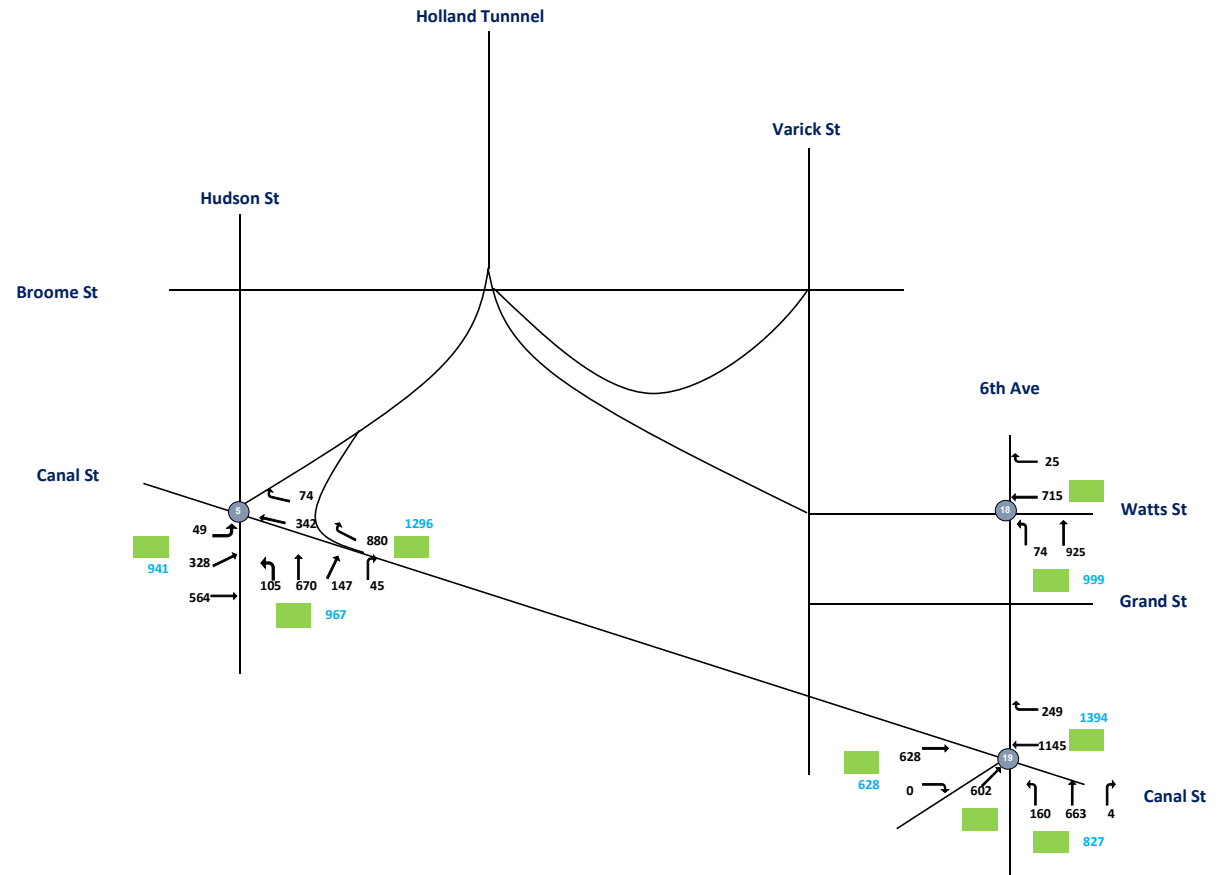

CBD Tolling
LM - Traffic Flowmap #4
AM With Action



- Legend:
- 1 - Intersection (2019 Collected Data)
 - 7 - Intersection (Uncollected Data)
 - 100 - ATR Volume
 - 100 - Approach Volume

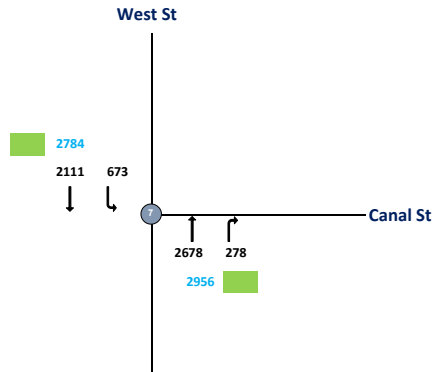

CBD Tolling
LM - Traffic Flowmap #5
AM With Action



- Legend:**
- 1 - Intersection (2019 Collected Data)
 - 7 - Intersection (Uncollected Data)
 - 100 - ATR Volume
 - 100 - Approach Volume

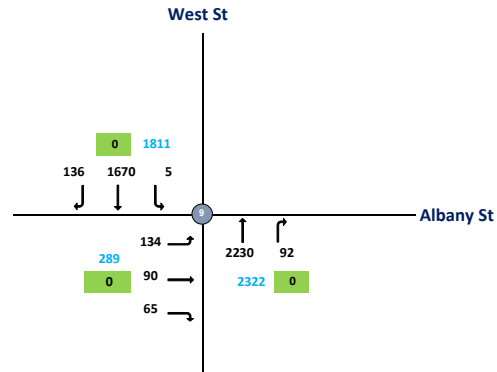

CBD Tolling
LM - Traffic Flowmap #6
AM With Action



- Legend:**
- 1 - Intersection (2019 Collected Data)
 - 7 - Intersection (Uncollected Data)
 - 100 - ATR Volume
 - 100 - Approach Volume
 - ↯ - Illegal movement

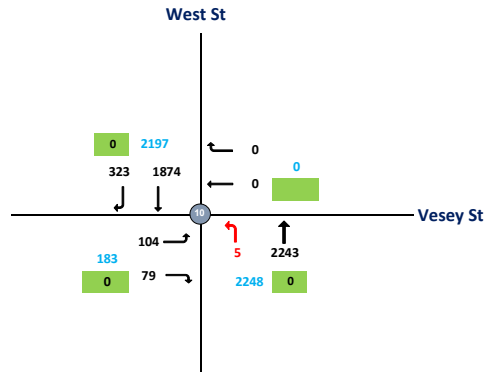

CBD Tolling
LM - Traffic Flowmap #7
AM With Action



- Legend:**
- 1 - Intersection (2019 Collected Data)
 - 7 - Intersection (Uncollected Data)
 - 100 - ATR Volume
 - 100 - Approach Volume

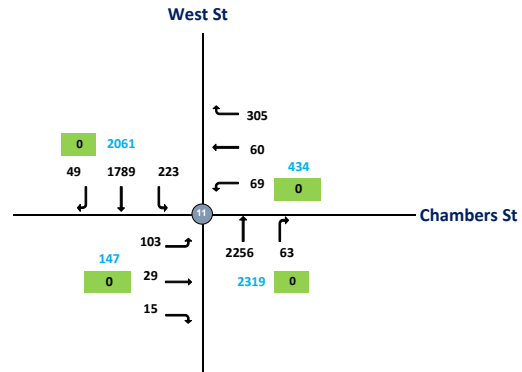

CBD Tolling
LM - Traffic Flowmap #8
AM With Action



- Legend:**
- Intersection (2019 Collected Data)
 - Intersection (Uncollected Data)
 - 100 - ATR Volume
 - 100 - Approach Volume

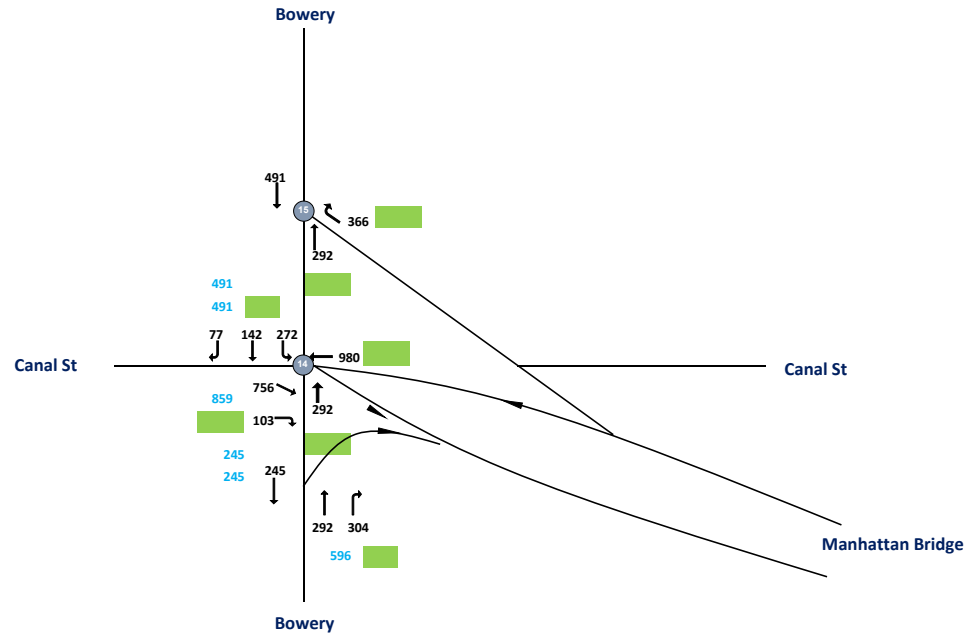

Intersection	Node	Approach	Total Vehicles					
			Inbound/Outbound					
			AM Peak Hour					
			L2	L	T	R	R2	Total
Edgar St. and Trinity Pl. 2019 (TMC-010)	1							
Edgar St.	1	EB	0	35	0	0	0	
478 Exit Ramp.	1	NE	0	0	0	0	0	
Trinity Pl.	1	NB	0	0	62	0	0	
Trinity Pl.	1	SB	0	0	0	0	0	97
Rector St. and Trinity Pl. 2019 (TMC-011)	2							
Rector St.	2	EB	0	97	34	0	0	
Rector St.	2	WB	0	0	0	0	0	
Trinity Pl.	2	NB	0	0	88	9	0	
Trinity Pl.	2	SB	0	0	0	0	0	228
West St. and HCT Exit. 2019 (TMC-012)	3							
-	3	EB	0	0	0	0	0	
HCT Exit.	3	WB	0	1722	0	0	0	
West St.	3	NB	0	0	1022	0	448	
West St.	3	SB	0	0	1008	0	0	4200
West St. and HCT Exit. 2019 (TMC-012)	333							
W. Thams St.	333	EB	0	0	0	0	0	
HCT Exit.	333	WB	0	0	0	1280	0	
West St.	333	NB	0	0	1022	0	0	
West St.	333	SB	0	0	1008	0	0	3310
Chambers St. and Centre St. 2018	4							
Chambers St.	4	EB	0	0	0	381	0	
-	4	WB	0	0	0	0	0	
Centre St.	4	NB	0	406	469	0	0	
Centre St.	4	SB	0	0	206	27	0	1489
Hudson St. and Canal St. 2018	5							
Canal St.	5	EB	49	328	564	0	0	
Canal St.	5	WB	0	0	342	74	0	
Hudson St.	5	NB	0	105	670	147	45	
Hudson St.	5	SB	0	0	0	0	0	2324

Hudson St. and Canal St.								
2018	555							
Canal St.	555	EB	0	0	609	0	0	
Canal St.	555	WB	0	0	416	880	0	
Hudson St.	555	NB	0	0	0	0	0	
Hudson St.	555	SB	0	0	0	0	0	1905
West St. and Canal St N.								
2018	7							
Canal St N.	7	EB	0	0	0	0	0	
-	7	WB	0	0	0	0	0	
West St.	7	NB	0	0	2678	278	0	
West St.	7	SB	0	673	2111	0	0	5740
West St. and Canal St S.								
2018	777							
-	777	EB	0	0	0	0	0	
Canal St S.	777	WB	0	0	0	0	0	
West St.	777	NB	0	0	2678	0	0	
West St.	777	SB	0	0	2784	0	0	5462
West St. and Albany St.								
2019 (TMC-013)	9							
Albany St.	9	EB	0	134	90	65	0	
-	9	WB	0	0	0	0	0	
West St.	9	NB	0	0	2230	92	0	
West St.	9	SB	0	5	1670	136	0	4422
West St. and Vesey St.								
2019 (TMC-014)	10							
Vesey St.	10	EB	0	104	0	79	0	
Vesey St.	10	WB	0	0	0	0	0	
West St.	10	NB	0	5	2243	0	0	
West St.	10	SB	0	0	1874	323	0	97
West St. and Chambers St.								
2019 (TMC-015)	11							
Chambers St.	11	EB	0	103	29	15	0	
Chambers St.	11	WB	0	69	60	305	0	
West St.	11	NB	0	0	2256	63	0	
West St.	11	SB	0	223	1789	49	0	4961

Bowey and Canal St./Manhattan Bridge Off-Ramp								
2018	14							
Canal St.	14	EB	0	0	756	103	0	
Manhattan Bridge Off-Ramp	14	WB	0	0	980	0	0	
Bowey	14	NB	0	0	292	304	0	
Bowey	14	SB	0	272	142	77	0	2926
Bowey and Manhattan Bridge Off-Ramp								
2018	15							
	15	EB	0	0	0	0	0	
Manhattan Bridge Off-Ramp	15	WB	0	0	0	366	0	
Bowey	15	NB	0	0	292	0	0	
Bowey	15	SB	0	0	491	0	0	1149
6th Ave. and Watts St								
2018	18							
Watts St	18	EB	0	0	0	0	0	
Watts St	18	WB	0	0	715	25	0	
6th Ave.	18	NB	0	74	925	0	0	
6th Ave.	18	SB	0	0	0	0	0	1739
6th Ave. and Canal St.								
2018	19							
Canal St.	19	EB	0	0	628	0	0	
Canal St.	19	WB	0	0	1145	249	0	
6th Ave.	19	NB	0	160	663	4	0	
Laight St.	19	NE	0	0	0	602	0	3451

CBD Tolling
LM - Traffic Flowmap #8
PM With Action



- Legend:**
- Intersection (2019 Collected Data)
 - Intersection (Uncollected Data)
 - 100 - ATR Volume
 - 100 - Approach Volume

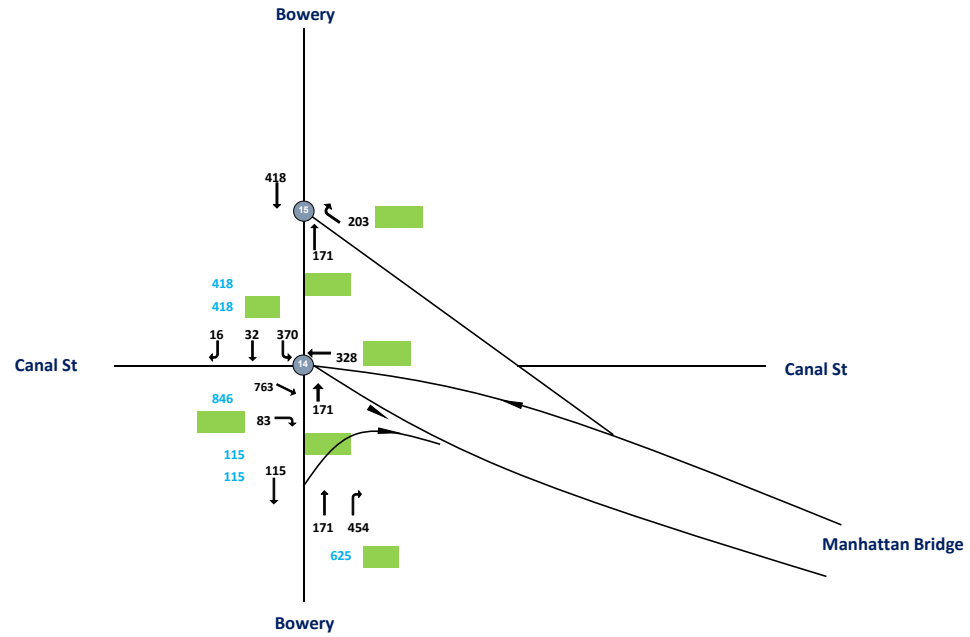

CBD Tolling
LM - Traffic Flowmap #1
MD With Action



- Legend:**
- 1 - Intersection (2019 Collected Data)
 - 7 - Intersection (Uncollected Data)
 - 100 - ATR Volume
 - 100 - Approach Volume

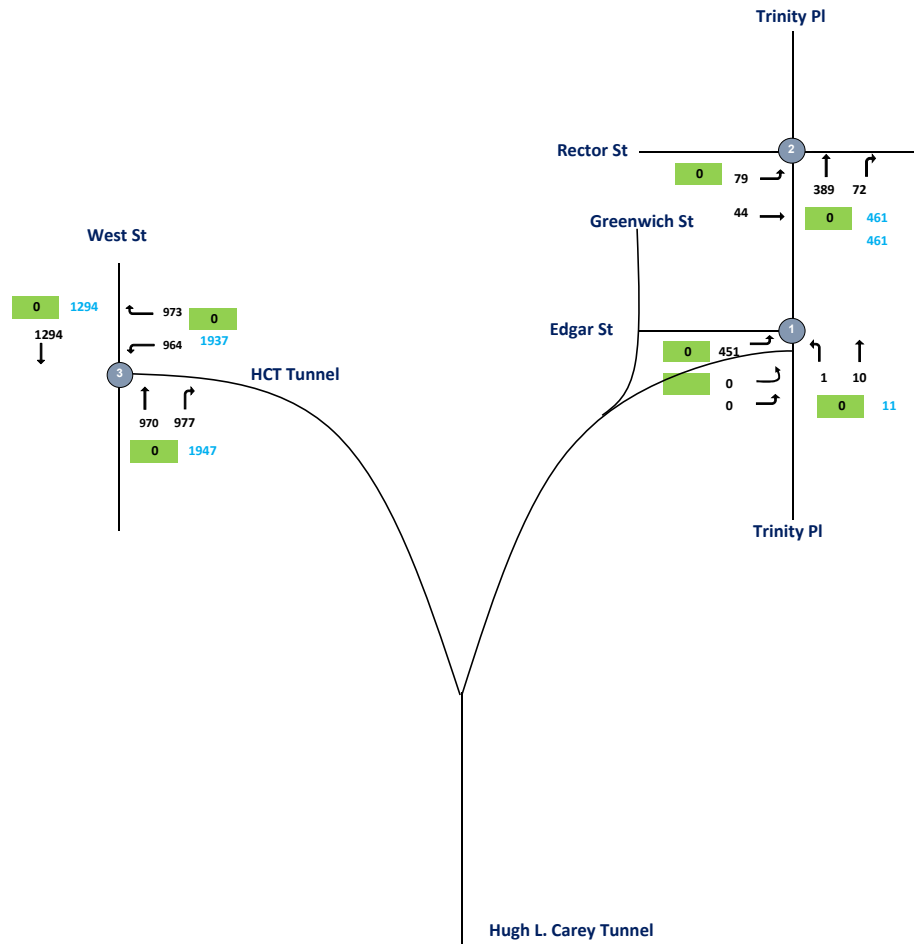

CBD Tolling
LM - Traffic Flowmap #2
MD With Action



- Legend:**
- 1 - Intersection (2019 Collected Data)
 - 7 - Intersection (Uncollected Data)
 - 100 - ATR Volume
 - 100 - Approach Volume

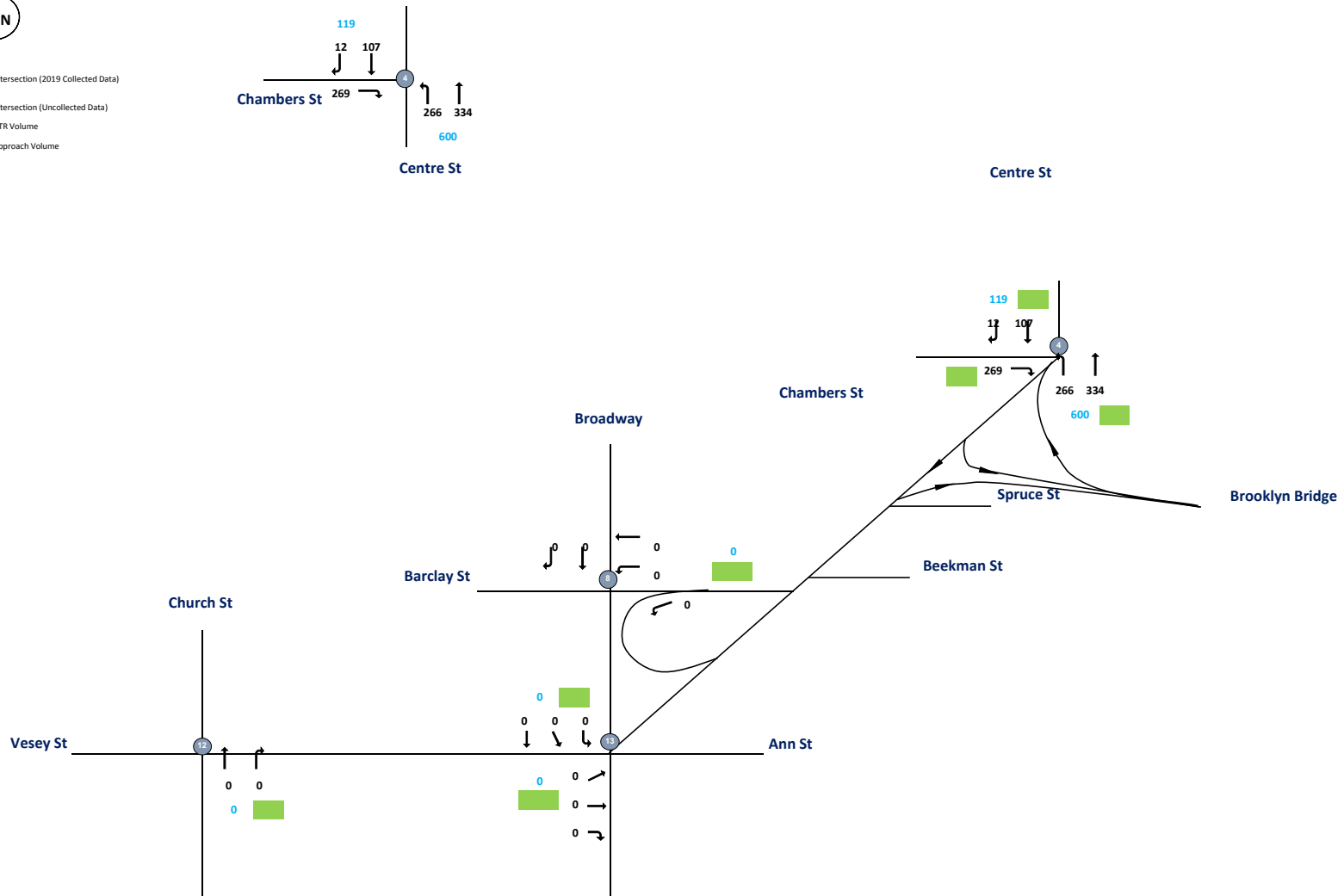

CBD Tolling
LM - Traffic Flowmap #3
MD With Action



- Legend:**
- Intersection (2019 Collected Data)
 - Intersection (Uncollected Data)
 - 100 - ATR Volume
 - 100 - Approach Volume

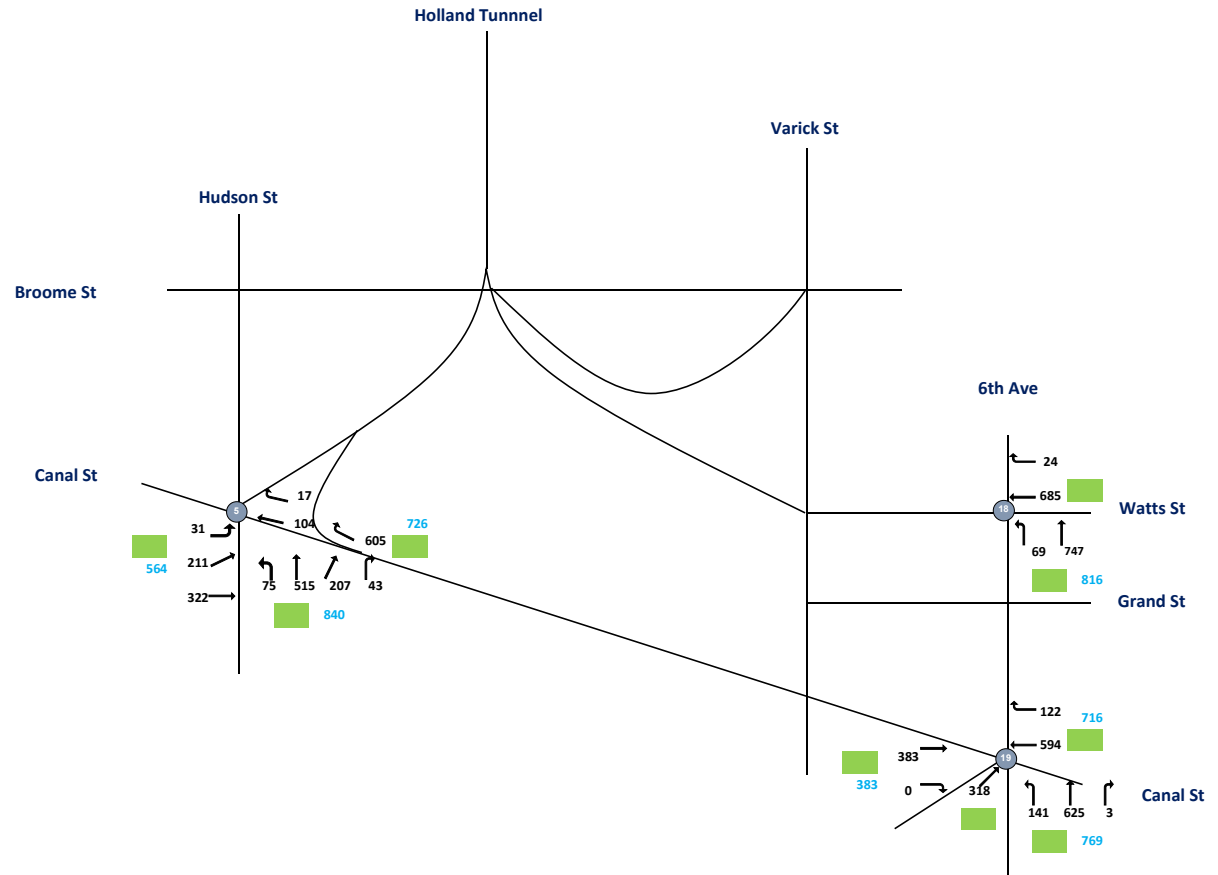

CBD Tolling
LM - Traffic Flowmap #4
MD With Action



- Legend:
- 1 - Intersection (2019 Collected Data)
 - 7 - Intersection (Uncollected Data)
 - 100 - ATR Volume
 - 100 - Approach Volume

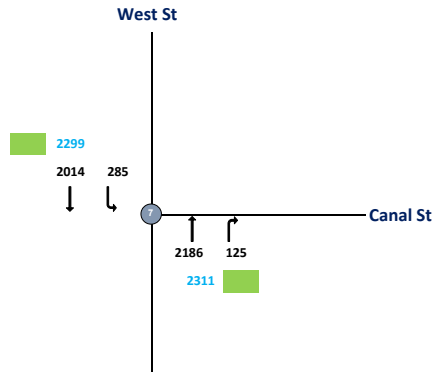

CBD Tolling
LM - Traffic Flowmap #5
MD With Action



- Legend:**
- 1 - Intersection (2019 Collected Data)
 - 7 - Intersection (Uncollected Data)
 - 100 - ATR Volume
 - 100 - Approach Volume

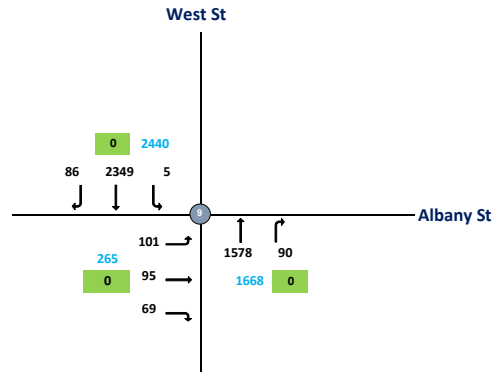

CBD Tolling
LM - Traffic Flowmap #6
MD With Action



- Legend:**
- 1 - Intersection (2019 Collected Data)
 - 7 - Intersection (Uncollected Data)
 - 100 - ATR Volume
 - 100 - Approach Volume
 - ↯ - Illegal movement

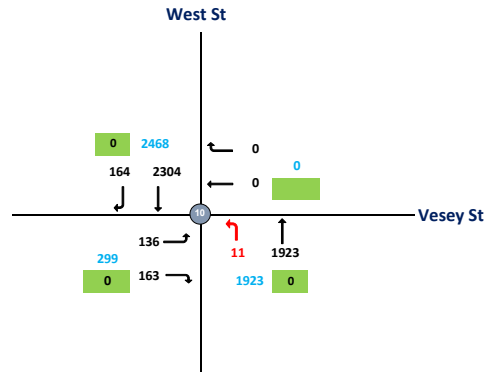

CBD Tolling
LM - Traffic Flowmap #7
MD With Action



- Legend:**
- 1 - Intersection (2019 Collected Data)
 - 7 - Intersection (Uncollected Data)
 - 100 - ATR Volume
 - 100 - Approach Volume

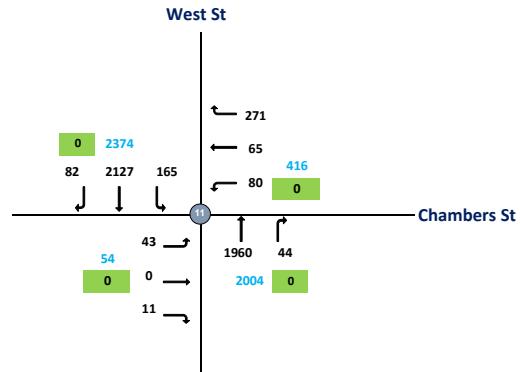

CBD Tolling
LM - Traffic Flowmap #8
MD With Action



- Legend:**
- Intersection (2019 Collected Data)
 - Intersection (Uncollected Data)
 - 100 - ATR Volume
 - 100 - Approach Volume

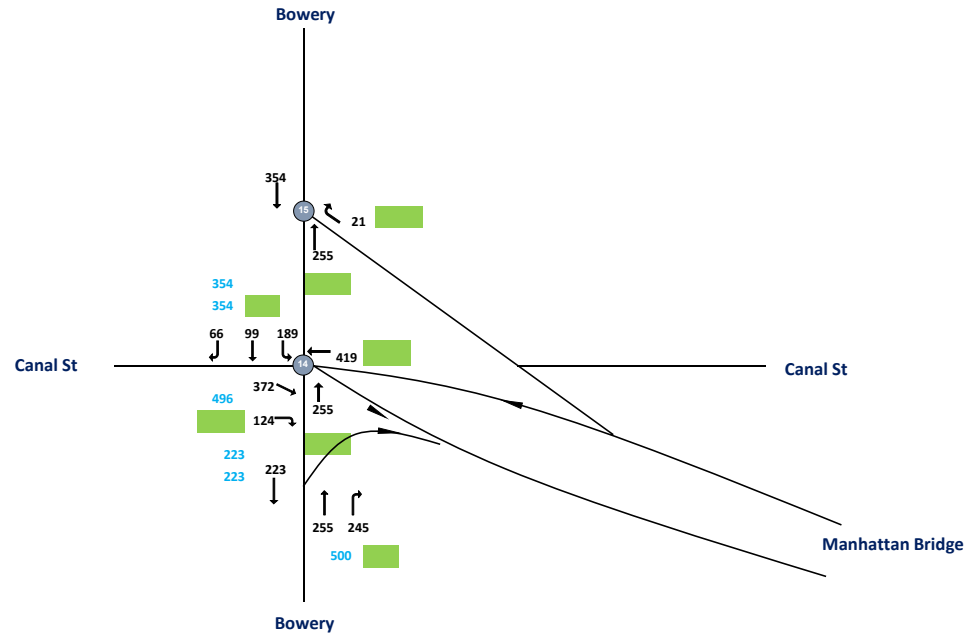

Intersection	Node	Approach	Total Vehicles						
			Inbound/Outbound						
			MD Peak Hour						
			L2	L	T	R	R2	Total	
Edgar St. and Trinity Pl. 2019 (TMC-010)	1								
Edgar St.	1	EB	0	451	0	0	0		
478 Exit Ramp.	1	NE	0	0	0	0	0		
Trinity Pl.	1	NB	0	1	10	0	0		
Trinity Pl.	1	SB	0	0	0	0	0		462
Rector St. and Trinity Pl. 2019 (TMC-011)	2								
Rector St.	2	EB	0	79	44	0	0		
Rector St.	2	WB	0	0	0	0	0		
Trinity Pl.	2	NB	0	0	389	72	0		
Trinity Pl.	2	SB	0	0	0	0	0		584
West St. and HCT Exit. 2019 (TMC-012)	3								
-	3	EB	0	0	0	0	0		
HCT Exit.	3	WB	0	964	0	0	0		
West St.	3	NB	0	0	970	0	977		
West St.	3	SB	0	0	1294	0	0		4205
West St. and HCT Exit. 2019 (TMC-012)	333								
W. Thams St.	333	EB	0	0	0	0	0		
HCT Exit.	333	WB	0	0	0	973	0		
West St.	333	NB	0	0	970	0	0		
West St.	333	SB	0	0	1294	0	0		3237
Chambers St. and Centre St. 2018	4								
Chambers St.	4	EB	0	0	0	269	0		
-	4	WB	0	0	0	0	0		
Centre St.	4	NB	0	266	334	0	0		
Centre St.	4	SB	0	0	107	12	0		988
Hudson St. and Canal St. 2018	5								
Canal St.	5	EB	31	211	322	0	0		
Canal St.	5	WB	0	0	104	17	0		
Hudson St.	5	NB	0	75	515	207	43		
Hudson St.	5	SB	0	0	0	0	0		1525

Hudson St. and Canal St.								
2018	555							
Canal St.	555	EB	0	0	365	0	0	
Canal St.	555	WB	0	0	121	605	0	
Hudson St.	555	NB	0	0	0	0	0	
Hudson St.	555	SB	0	0	0	0	0	1091
West St. and Canal St N.								
2018	7							
Canal St N.	7	EB	0	0	0	0	0	
-	7	WB	0	0	0	0	0	
West St.	7	NB	0	0	2186	125	0	
West St.	7	SB	0	285	2014	0	0	4610
West St. and Canal St S.								
2018	777							
-	777	EB	0	0	0	0	0	
Canal St S.	777	WB	0	0	0	0	0	
West St.	777	NB	0	0	2186	0	0	
West St.	777	SB	0	0	2299	0	0	4485
West St. and Albany St.								
2019 (TMC-013)	9							
Albany St.	9	EB	0	101	95	69	0	
-	9	WB	0	0	0	0	0	
West St.	9	NB	0	0	1578	90	0	
West St.	9	SB	0	5	2349	86	0	4373
West St. and Vesey St.								
2019 (TMC-014)	10							
Vesey St.	10	EB	0	136	0	163	0	
Vesey St.	10	WB	0	0	0	0	0	
West St.	10	NB	0	11	1923	0	0	
West St.	10	SB	0	0	2304	164	0	462
West St. and Chambers St.								
2019 (TMC-015)	11							
Chambers St.	11	EB	0	43	0	11	0	
Chambers St.	11	WB	0	80	65	271	0	
West St.	11	NB	0	0	1960	44	0	
West St.	11	SB	0	165	2127	82	0	4848

Bowey and Canal St./Manhattan Bridge Off-Ramp								
2018	14							
Canal St.	14	EB	0	0	372	124	0	
Manhattan Bridge Off-Ramp	14	WB	0	0	419	0	0	
Bowey	14	NB	0	0	255	245	0	
Bowey	14	SB	0	189	99	66	0	1769
Bowey and Manhattan Bridge Off-Ramp								
2018	15							
	15	EB	0	0	0	0	0	
Manhattan Bridge Off-Ramp	15	WB	0	0	0	21	0	
Bowey	15	NB	0	0	255	0	0	
Bowey	15	SB	0	0	354	0	0	630
6th Ave. and Watts St								
2018	18							
Watts St	18	EB	0	0	0	0	0	
Watts St	18	WB	0	0	685	24	0	
6th Ave.	18	NB	0	69	747	0	0	
6th Ave.	18	SB	0	0	0	0	0	1525
6th Ave. and Canal St.								
2018	19							
Canal St.	19	EB	0	0	383	0	0	
Canal St.	19	WB	0	0	594	122	0	
6th Ave.	19	NB	0	141	625	3	0	
Laight St.	19	NE	0	0	0	318	0	2186

CBD Tolling
LM - Traffic Flowmap #1
PM With Action



- Legend:**
- 1 - Intersection (2019 Collected Data)
 - 7 - Intersection (Uncollected Data)
 - 100 - ATR Volume
 - 100 - Approach Volume

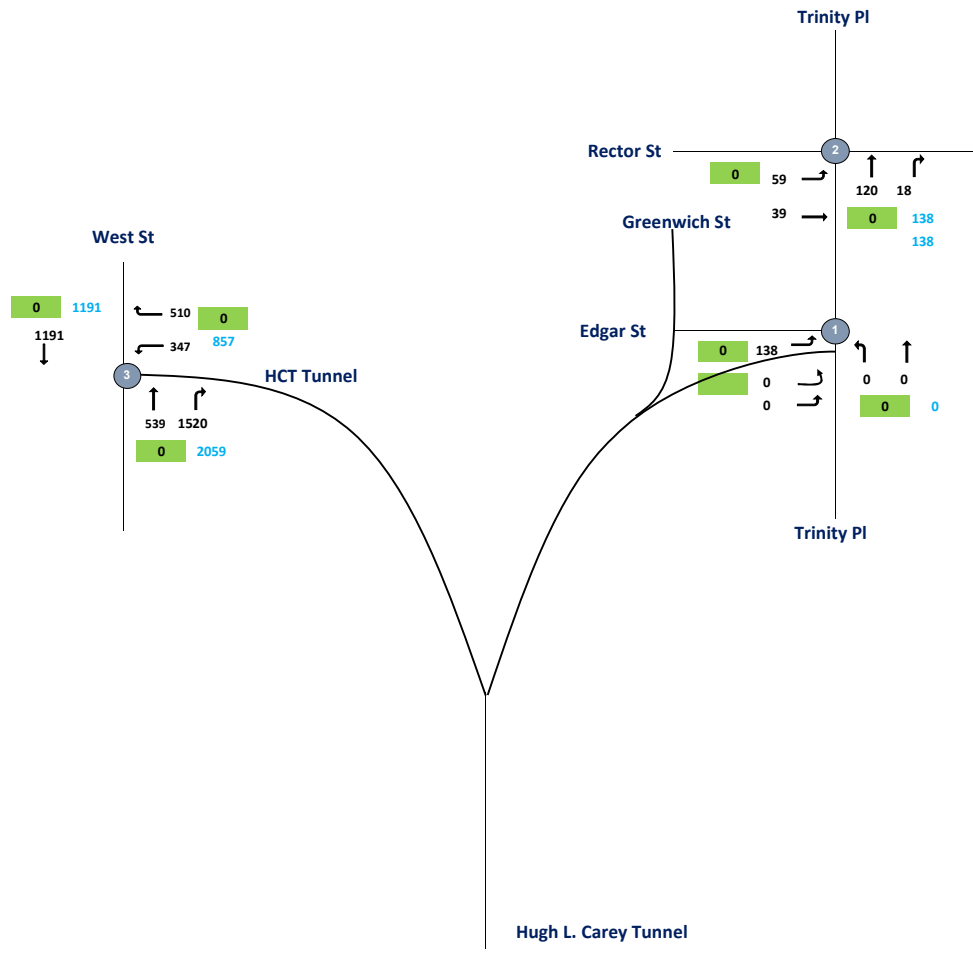

CBD Tolling
LM - Traffic Flowmap #2
PM With Action



- Legend:**
- 1 - Intersection (2019 Collected Data)
 - 7 - Intersection (Uncollected Data)
 - 100 - ATR Volume
 - 100 - Approach Volume

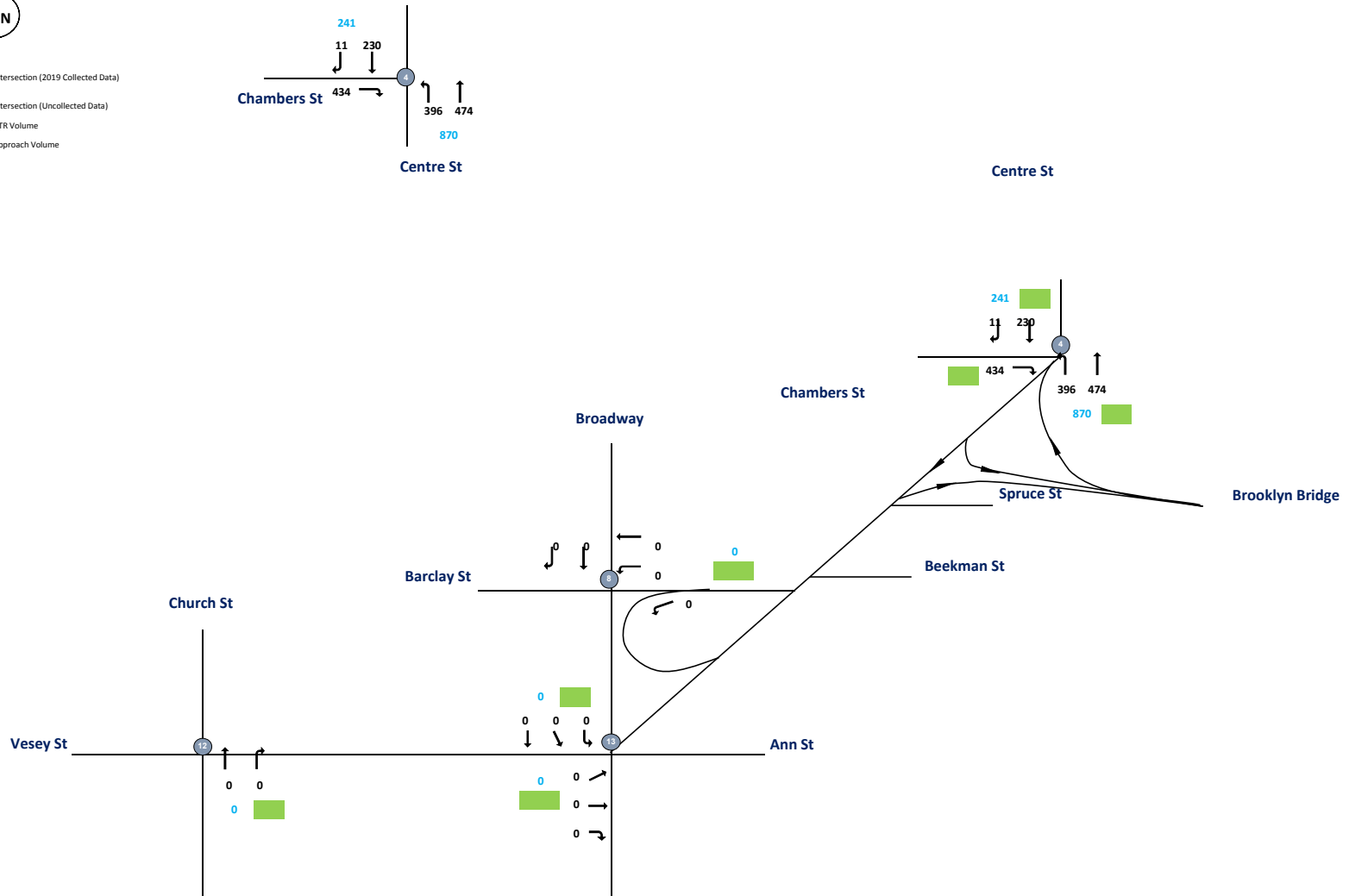

CBD Tolling
LM - Traffic Flowmap #3
PM With Action



- Legend:**
- Intersection (2019 Collected Data)
 - Intersection (Uncollected Data)
 - 100 - ATR Volume
 - 100 - Approach Volume

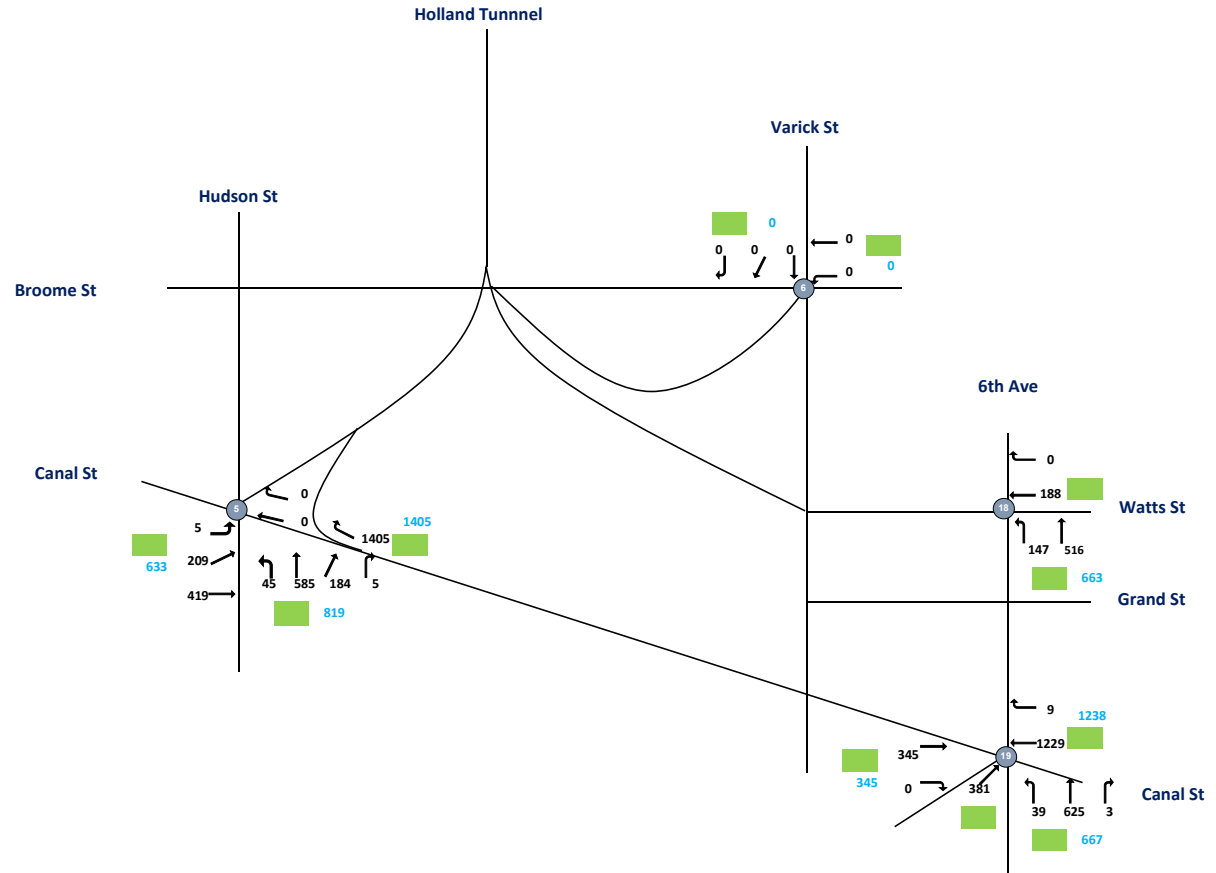

CBD Tolling
LM - Traffic Flowmap #4
PM With Action



- Legend:
- 1 - Intersection (2019 Collected Data)
 - 7 - Intersection (Uncollected Data)
 - 100 - ATR Volume
 - 100 - Approach Volume

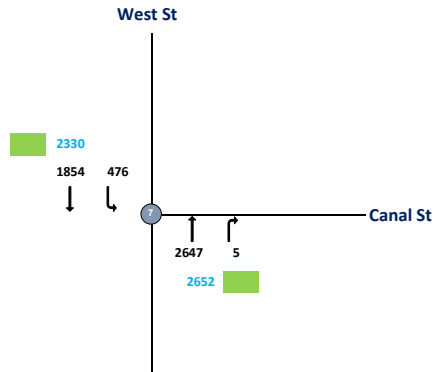

CBD Tolling
LM - Traffic Flowmap #5
PM With Action



- Legend:**
- 1 - Intersection (2019 Collected Data)
 - 7 - Intersection (Uncollected Data)
 - 100 - ATR Volume
 - 100 - Approach Volume

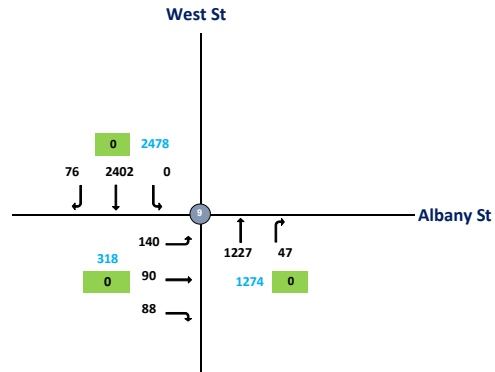

CBD Tolling
LM - Traffic Flowmap #6
PM With Action



- Legend:**
- 1 - Intersection (2019 Collected Data)
 - 7 - Intersection (Uncollected Data)
 - 100 - ATR Volume
 - 100 - Approach Volume
 - ↯ - Illegal movement

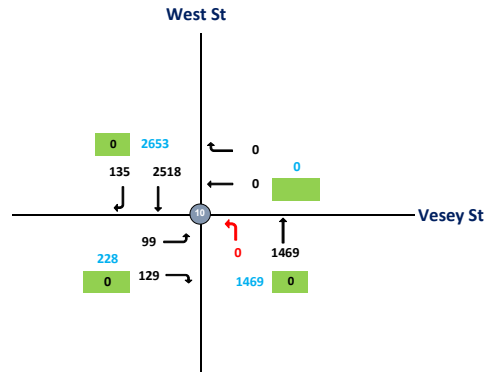

CBD Tolling
LM - Traffic Flowmap #7
PM With Action



- Legend:**
- 1 - Intersection (2019 Collected Data)
 - 7 - Intersection (Uncollected Data)
 - 100 - ATR Volume
 - 100 - Approach Volume

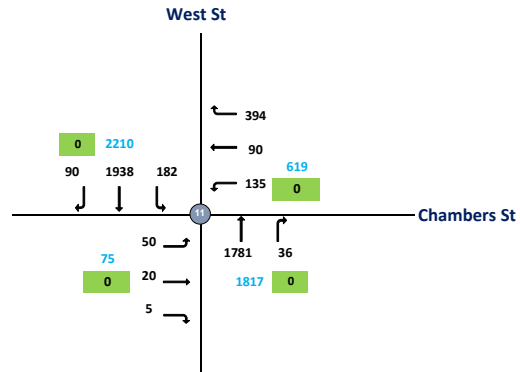

Intersection	Node	Approach	Total Vehicles					
			Inbound/Outbound					
			PM Peak Hour					
			L2	L	T	R	R2	Total
Edgar St. and Trinity Pl. 2019 (TMC-010)	1							
Edgar St.	1	EB	0	138	0	0	0	
478 Exit Ramp.	1	NE	0	0	0	0	0	
Trinity Pl.	1	NB	0	0	0	0	0	
Trinity Pl.	1	SB	0	0	0	0	0	138
Rector St. and Trinity Pl. 2019 (TMC-011)	2							
Rector St.	2	EB	0	59	39	0	0	
Rector St.	2	WB	0	0	0	0	0	
Trinity Pl.	2	NB	0	0	120	18	0	
Trinity Pl.	2	SB	0	0	0	0	0	236
West St. and HCT Exit. 2019 (TMC-012)	3							
-	3	EB	0	0	0	0	0	
HCT Exit.	3	WB	0	347	0	0	0	
West St.	3	NB	0	0	539	0	1520	
West St.	3	SB	0	0	1191	0	0	3597
West St. and HCT Exit. 2019 (TMC-012)	333							
W. Thams St.	333	EB	0	0	0	0	0	
HCT Exit.	333	WB	0	0	0	510	0	
West St.	333	NB	0	0	539	0	0	
West St.	333	SB	0	0	1191	0	0	2240
Chambers St. and Centre St. 2018	4							
Chambers St.	4	EB	0	0	0	434	0	
-	4	WB	0	0	0	0	0	
Centre St.	4	NB	0	396	474	0	0	
Centre St.	4	SB	0	0	230	11	0	1545
Hudson St. and Canal St. 2018	5							
Canal St.	5	EB	5	209	419	0	0	
Canal St.	5	WB	0	0	0	0	0	
Hudson St.	5	NB	0	45	585	184	5	
Hudson St.	5	SB	0	0	0	0	0	1452

Hudson St. and Canal St.								
2018	555							
Canal St.	555	EB	0	0	424	0	0	
Canal St.	555	WB	0	0	0	1405	0	
Hudson St.	555	NB	0	0	0	0	0	
Hudson St.	555	SB	0	0	0	0	0	1829
West St. and Canal St N.								
2018	7							
Canal St N.	7	EB	0	0	0	0	0	
-	7	WB	0	0	0	0	0	
West St.	7	NB	0	0	2647	5	0	
West St.	7	SB	0	476	1854	0	0	4982
West St. and Canal St S.								
2018	777							
-	777	EB	0	0	0	0	0	
Canal St S.	777	WB	0	0	0	0	0	
West St.	777	NB	0	0	2647	0	0	
West St.	777	SB	0	0	2330	0	0	4977
West St. and Albany St.								
2019 (TMC-013)	9							
Albany St.	9	EB	0	140	90	88	0	
-	9	WB	0	0	0	0	0	
West St.	9	NB	0	0	1227	47	0	
West St.	9	SB	0	0	2402	76	0	4070
West St. and Vesey St.								
2019 (TMC-014)	10							
Vesey St.	10	EB	0	99	0	129	0	
Vesey St.	10	WB	0	10	0	0	0	
West St.	10	NB	0	0	1469	0	0	
West St.	10	SB	0	0	2518	135	0	138
West St. and Chambers St.								
2019 (TMC-015)	11							
Chambers St.	11	EB	0	50	20	5	0	
Chambers St.	11	WB	0	135	90	394	0	
West St.	11	NB	0	0	1781	36	0	
West St.	11	SB	0	182	1938	90	0	4721

Bowey and Canal St./Manhattan Bridge Off-Ramp								
2018	14							
Canal St.	14	EB	0	0	763	83	0	
Manhattan Bridge Off-Ramp	14	WB	0	0	328	0	0	
Bowey	14	NB	0	0	171	454	0	
Bowey	14	SB	0	370	32	16	0	2217
Bowey and Manhattan Bridge Off-Ramp								
2018	15							
	15	EB	0	0	0	0	0	
Manhattan Bridge Off-Ramp	15	WB	0	0	0	203	0	
Bowey	15	NB	0	0	171	0	0	
Bowey	15	SB	0	0	418	0	0	792
6th Ave. and Watts St								
2018	18							
Watts St	18	EB	0	0	0	0	0	
Watts St	18	WB	0	0	188	0	0	
6th Ave.	18	NB	0	147	516	0	0	
6th Ave.	18	SB	0	0	0	0	0	851
6th Ave. and Canal St.								
2018	19							
Canal St.	19	EB	0	0	345	0	0	
Canal St.	19	WB	0	0	1229	9	0	
6th Ave.	19	NB	0	39	625	3	0	
Laight St.	19	NE	0	0	0	381	0	2631

CBD Tolling
LT #1 - Traffic Flowmap
AM With-Action



- Legend:**
- 1 - Intersection (2019 Collected Data)
 - 7 - Intersection (Pre-2019 Collected Data)
 - 100 - ATR Volume
 - 100 - Approach Volume

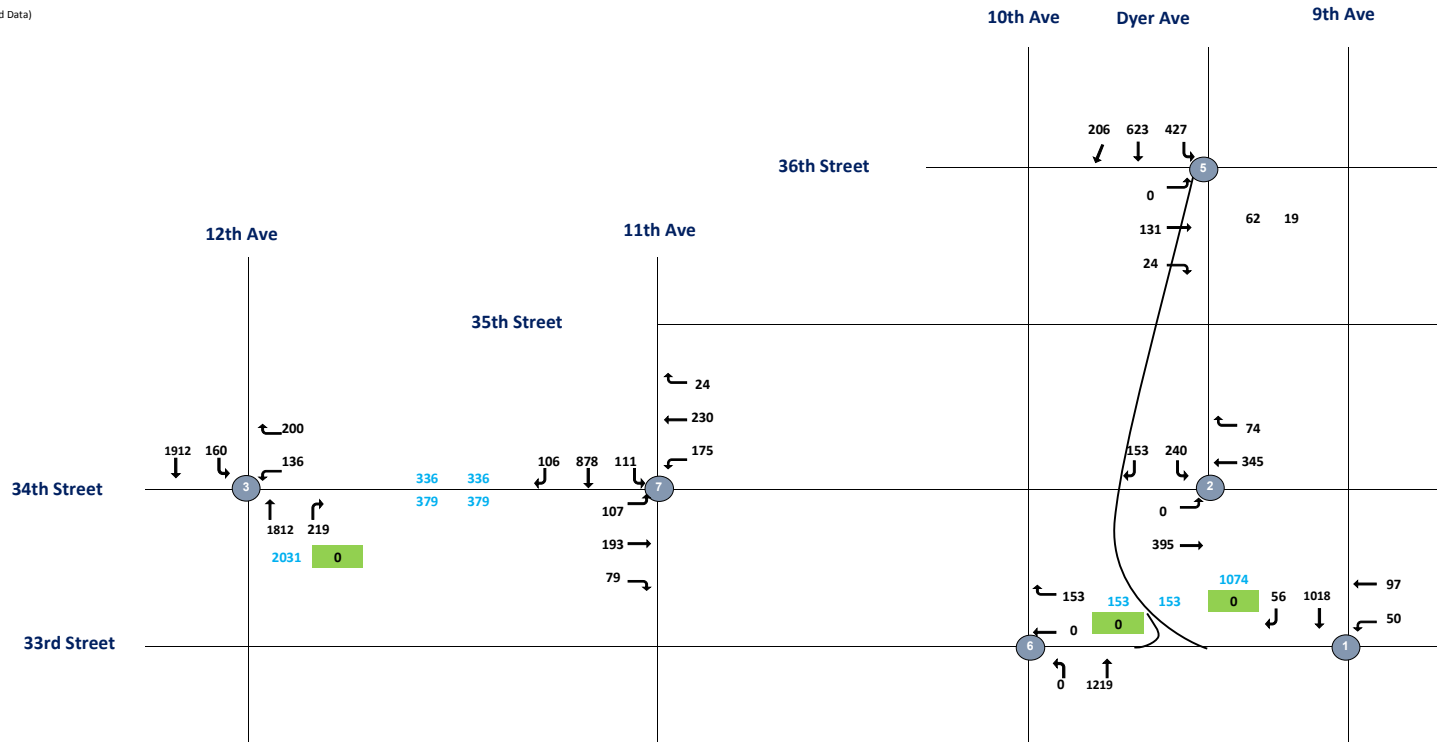

CBD Tolling
LT #2 - Traffic Flowmap
AM With-Action



- Legend:**
- 1 - Intersection (2019 Collected Data)
 - 7 - Intersection (Pre-2019 Collected Data)
 - 100 - ATR Volume
 - 100 - Approach Volume

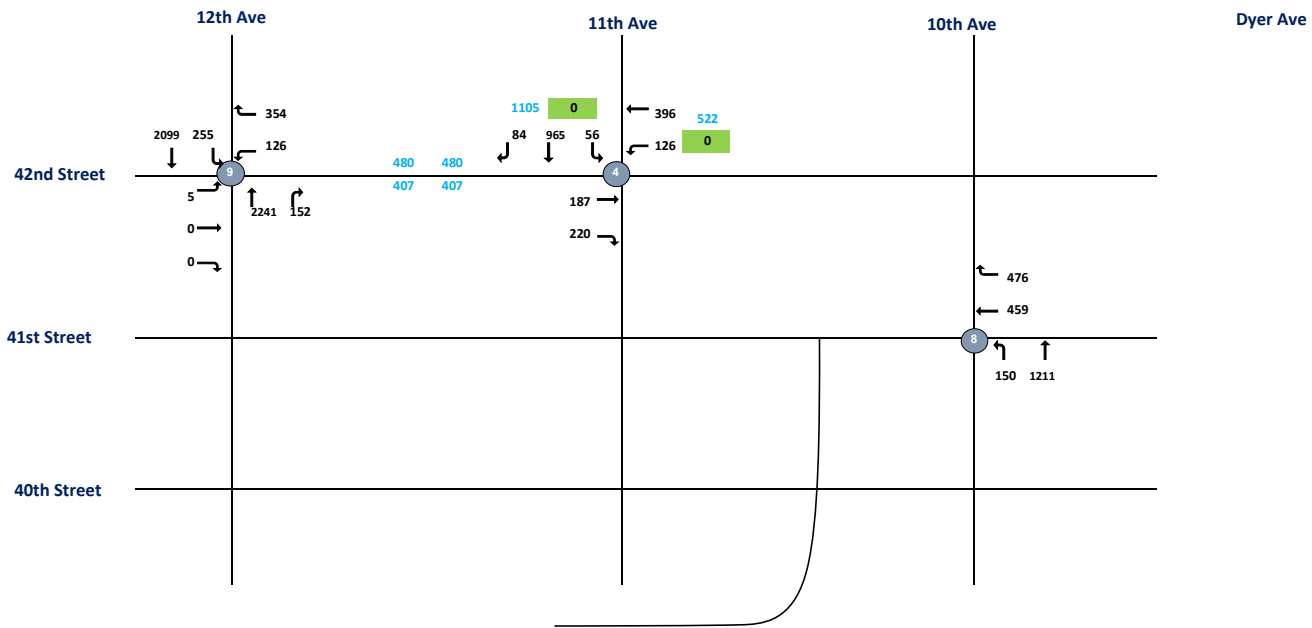

LT

8:00:00 AM

Intersection	Node	Approach	Total Vehicles					
			Inbound/Outbound					
			AM Peak Hour					
			L2	L	T	R	R2	Total
33rd Street and 9th Avenue 2019 (WRY-TMC-109)	1							
33rd Street	1	EB	0	0	0	0	0	
33rd Street	1	WB	0	50	97	0	0	
9th Avenue	1	NB	0	0	0	0	0	
9th Avenue	1	SB	0	0	1018	56	0	1221
34th Street and Dyer Avenue 2019 (WRY-TMC-105)	2							
34th Street	2	EB	0	0	395	0	0	
34th Street	2	WB	0	0	345	74	0	
Dyer Avenue	2	NB	0	0	0	0	0	
Dyer Avenue	2	SB	0	240	0	153	0	1207
34th Street and 12th Avenue 2019 (PABT-TMC-055)	3							
34th Street	3	EB	0	0	0	0	0	
34th Street	3	WB	0	136	0	200	0	
12th Avenue	3	NB	0	0	1812	219	0	
12th Avenue	3	SB	0	160	1912	0	0	4439
42nd Street and 11th Avenue 2019 (PABT-TMC-052)	4							
42nd Street	4	EB	0	0	187	220	0	
42nd Street	4	WB	0	126	396	0	0	
11th Avenue	4	NB	0	0	0	0	0	
11th Avenue	4	SB	0	56	965	84	0	2034
36th Street and Dyer Avenue 2019 (PABT-TMC-060)	5							
36th Street	5	EB	0	0	131	24	0	
36th Street	5	WB	0	0	0	0	0	
Dyer Avenue	5	NB	0	0	62	19	0	
Dyer Avenue	5	SB	0	427	623	206	0	1492
33rd Street and 10th Avenue 2019 (WRY-TMC-108)	6							
33rd Street	6	EB	0	0	0	0	0	
33rd Street	6	WB	0	0	0	153	0	
10th Avenue	6	NB	0	0	1219	0	0	
10th Avenue	6	SB	0	0	0	0	0	1372

34th Street and 11th Avenue 2019 (PABT-TMC-044)	7								
34th Street	7	EB	0	107	193	79	0		
34th Street	7	WB	0	175	230	24	0		
11th Avenue	7	NB	0	0	0	0	0		
11th Avenue	7	SB	0	111	878	106	0		1903
34th Street and 11th Avenue 2019 (PABT-TMC-040)	8								
34th Street	8	EB	0	0	0	0	0		
34th Street	8	WB	0	0	459	476	0		
11th Avenue	8	NB	0	150	1211	0	0		
11th Avenue	8	SB	0	0	0	0	0		2296
42nd Street and 12th Avenue 2019 (PABT-TMC-057)	9								
42nd Street	9	EB	0	5	0	0	0		
42nd Street	9	WB	0	126	0	354	0		
12th Avenue	9	NB	0	0	2241	152	0		
12th Avenue	9	SB	0	255	2099	0	0		5232

CBD Tolling
LT #1 - Traffic Flowmap
MD With-Action



- Legend:**
- ① - Intersection (2019 Collected Data)
 - ⑦ - Intersection (Pre-2019 Collected Data)
 - 100 - ATR Volume
 - 100 - Approach Volume

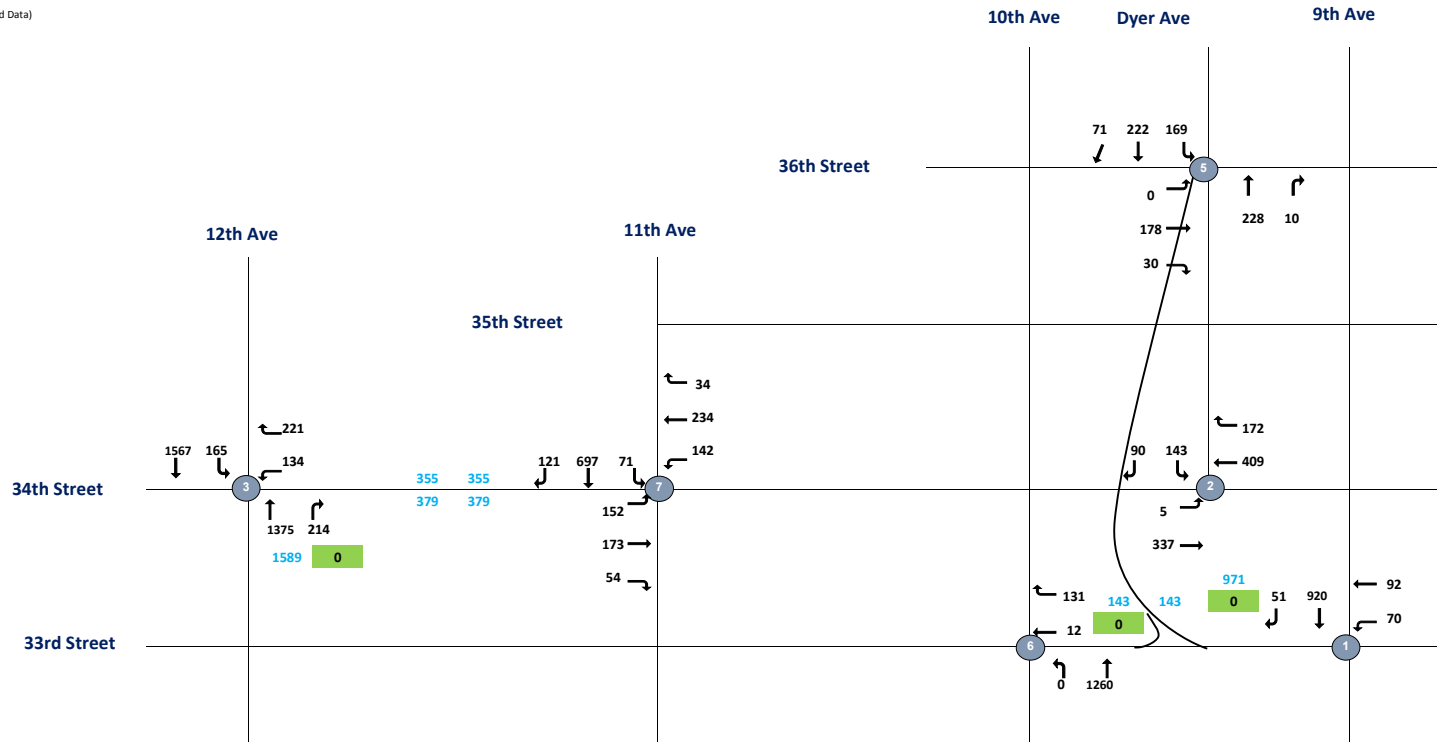

CBD Tolling
LT #2 - Traffic Flowmap
MD With-Action



- Legend:**
- Intersection (2019 Collected Data)
 - Intersection (Pre-2019 Collected Data)
 - 100 - ATR Volume
 - 100 - Approach Volume

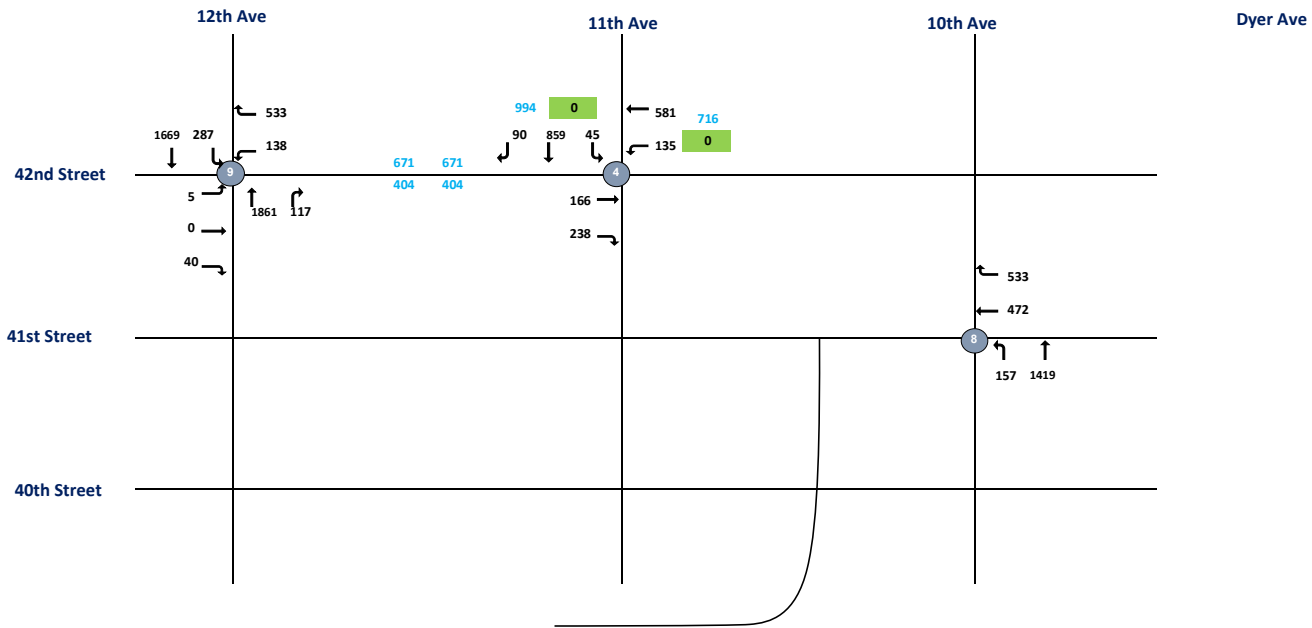

LT

12:00:00 PM

Intersection	Node	Approach	Total Vehicles					
			Inbound/Outbound					
			MD Peak Hour					
			L2	L	T	R	R2	Total
33rd Street and 9th Avenue 2019 (WRY-TMC-109)	1							
33rd Street	1	EB	0	0	0	0	0	
33rd Street	1	WB	0	70	92	0	0	
9th Avenue	1	NB	0	0	0	0	0	
9th Avenue	1	SB	0	0	920	51	0	1133
34th Street and Dyer Avenue 2019 (WRY-TMC-105)	2							
34th Street	2	EB	0	5	337	0	0	
34th Street	2	WB	0	0	409	172	0	
Dyer Avenue	2	NB	0	0	0	0	0	
Dyer Avenue	2	SB	0	143	0	90	0	1156
34th Street and 12th Avenue 2019 (PABT-TMC-055)	3							
34th Street	3	EB	0	0	0	0	0	
34th Street	3	WB	0	134	0	221	0	
12th Avenue	3	NB	0	0	1375	214	0	
12th Avenue	3	SB	0	165	1567	0	0	3676
42nd Street and 11th Avenue 2019 (PABT-TMC-052)	4							
42nd Street	4	EB	0	0	166	238	0	
42nd Street	4	WB	0	135	581	0	0	
11th Avenue	4	NB	0	0	0	0	0	
11th Avenue	4	SB	0	45	859	90	0	2114
36th Street and Dyer Avenue 2019 (PABT-TMC-060)	5							
36th Street	5	EB	0	0	178	30	0	
36th Street	5	WB	0	0	0	0	0	
Dyer Avenue	5	NB	0	0	228	10	0	
Dyer Avenue	5	SB	0	169	222	71	0	908
33rd Street and 10th Avenue 2019 (WRY-TMC-108)	6							
33rd Street	6	EB	0	0	0	0	0	
33rd Street	6	WB	0	0	12	131	0	
10th Avenue	6	NB	0	0	1260	0	0	
10th Avenue	6	SB	0	0	0	0	0	1403

34th Street and 11th Avenue 2019 (PABT-TMC-044)	7								
34th Street	7	EB	0	152	173	54	0		
34th Street	7	WB	0	142	234	34	0		
11th Avenue	7	NB	0	0	0	0	0		
11th Avenue	7	SB	0	71	697	121	0		1678
34th Street and 11th Avenue 2019 (PABT-TMC-040)	8								
34th Street	8	EB	0	0	0	0	0		
34th Street	8	WB	0	0	472	533	0		
11th Avenue	8	NB	0	157	1419	0	0		
11th Avenue	8	SB	0	0	0	0	0		2581
42nd Street and 12th Avenue 2019 (PABT-TMC-057)	9								
42nd Street	9	EB	0	5	0	40	0		
42nd Street	9	WB	0	138	0	533	0		
12th Avenue	9	NB	0	0	1861	117	0		
12th Avenue	9	SB	0	287	1669	0	0		4650

CBD Tolling
LT #1 - Traffic Flowmap
PM With-Action



- Legend:**
- ① - Intersection (2019 Collected Data)
 - ⑦ - Intersection (Pre-2019 Collected Data)
 - 100 - ATR Volume
 - 100 - Approach Volume

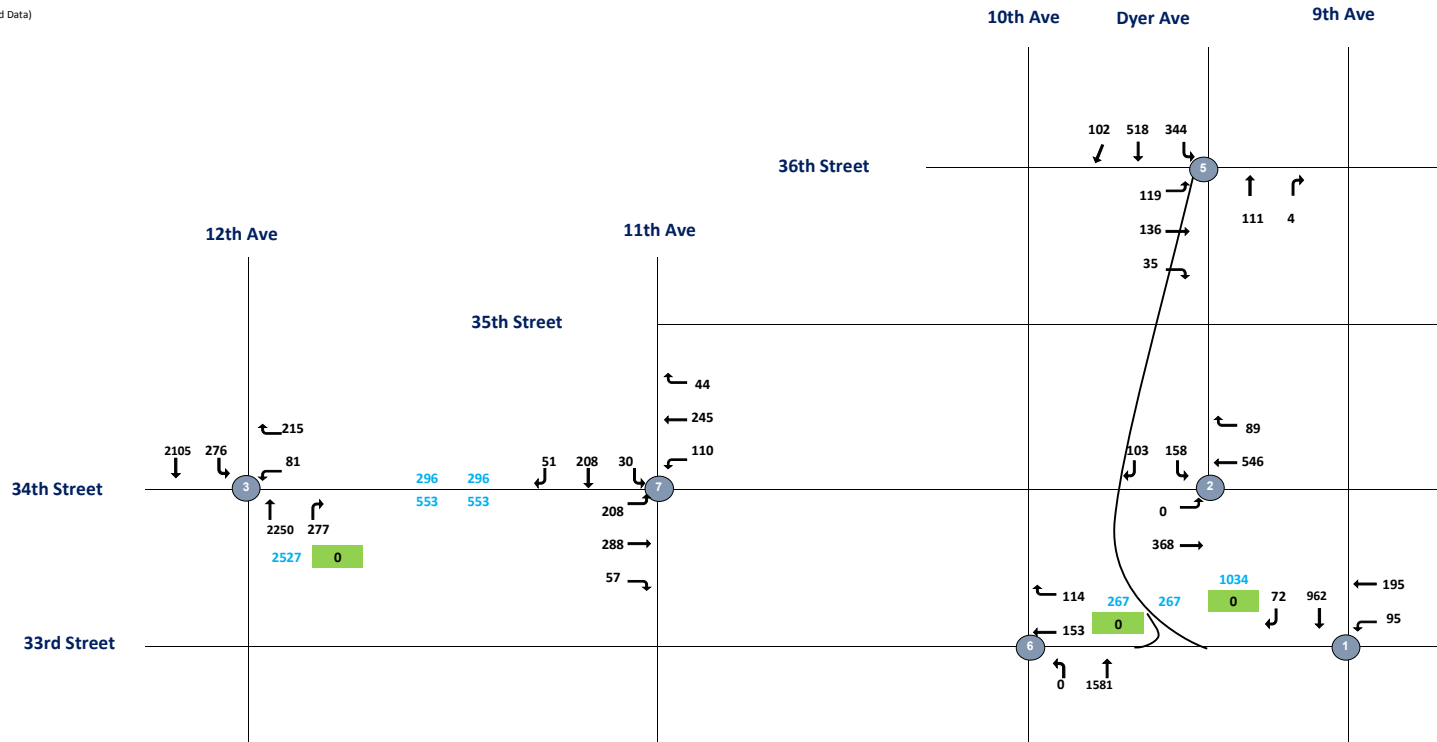

CBD Tolling
LT #2 - Traffic Flowmap
PM With-Action



- Legend:**
- 1 - Intersection (2019 Collected Data)
 - 7 - Intersection (Pre-2019 Collected Data)
 - 100 - ATR Volume
 - 100 - Approach Volume

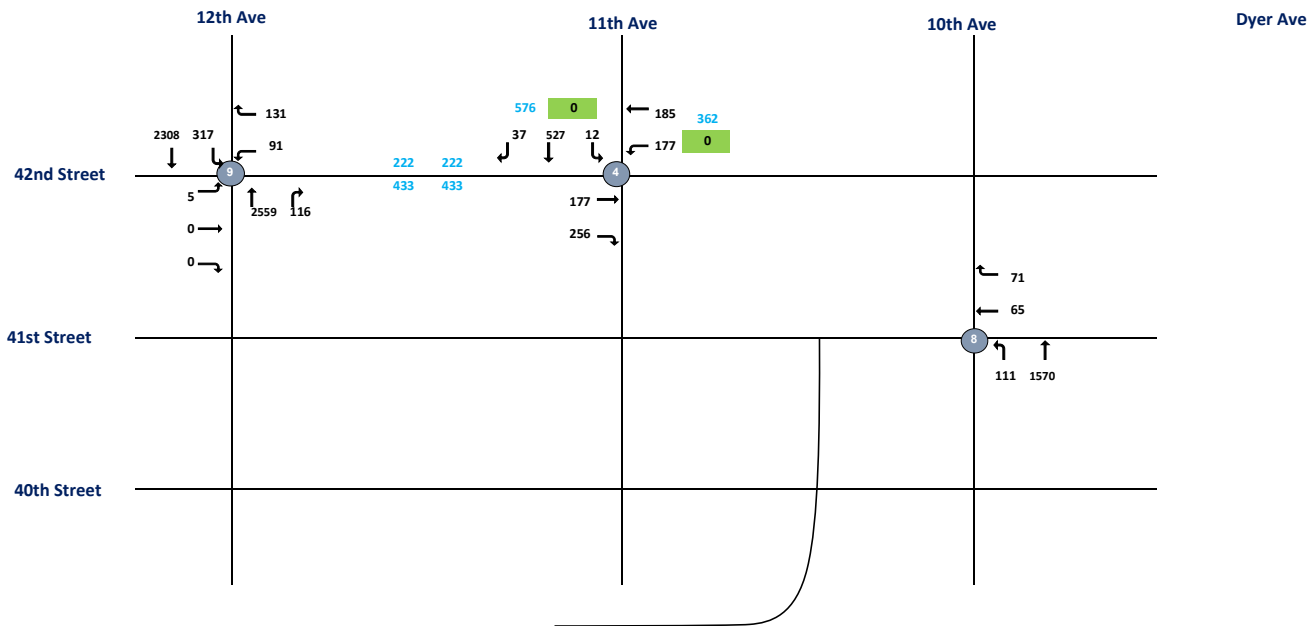

LT

5:00:00 PM

Intersection	Node	Approach	Total Vehicles					
			Inbound/Outbound					
			PM Peak Hour					
			L2	L	T	R	R2	Total
33rd Street and 9th Avenue 2019 (WRY-TMC-109)	1							
33rd Street	1	EB	0	0	0	0	0	
33rd Street	1	WB	0	95	195	0	0	
9th Avenue	1	NB	0	0	0	0	0	
9th Avenue	1	SB	0	0	962	72	0	1324
34th Street and Dyer Avenue 2019 (WRY-TMC-105)	2							
34th Street	2	EB	0	0	368	0	0	
34th Street	2	WB	0	0	546	89	0	
Dyer Avenue	2	NB	0	0	0	0	0	
Dyer Avenue	2	SB	0	158	0	103	0	1264
34th Street and 12th Avenue 2019 (PABT-TMC-055)	3							
34th Street	3	EB	0	0	0	0	0	
34th Street	3	WB	0	81	0	215	0	
12th Avenue	3	NB	0	0	2250	277	0	
12th Avenue	3	SB	0	276	2105	0	0	5204
42nd Street and 11th Avenue 2019 (PABT-TMC-052)	4							
42nd Street	4	EB	0	0	177	256	0	
42nd Street	4	WB	0	177	185	0	0	
11th Avenue	4	NB	0	0	0	0	0	
11th Avenue	4	SB	0	12	527	37	0	1371
36th Street and Dyer Avenue 2019 (PABT-TMC-060)	5							
36th Street	5	EB	0	119	136	35	0	
36th Street	5	WB	0	0	0	0	0	
Dyer Avenue	5	NB	0	0	111	4	0	
Dyer Avenue	5	SB	0	344	518	102	0	1369
33rd Street and 10th Avenue 2019 (WRY-TMC-108)	6							
33rd Street	6	EB	0	0	0	0	0	
33rd Street	6	WB	0	0	153	114	0	
10th Avenue	6	NB	0	0	1581	0	0	
10th Avenue	6	SB	0	0	0	0	0	1848

34th Street and 11th Avenue 2019 (PABT-TMC-044)	7								
34th Street	7	EB	0	208	288	57	0		
34th Street	7	WB	0	110	245	44	0		
11th Avenue	7	NB	0	0	0	0	0		
11th Avenue	7	SB	0	30	208	51	0		1241
34th Street and 11th Avenue 2019 (PABT-TMC-040)	8								
34th Street	8	EB	0	0	0	0	0		
34th Street	8	WB	0	0	65	71	0		
11th Avenue	8	NB	0	111	1570	0	0		
11th Avenue	8	SB	0	0	0	0	0		1817
42nd Street and 12th Avenue 2019 (PABT-TMC-057)	9								
42nd Street	9	EB	0	5	0	0	0		
42nd Street	9	WB	0	91	0	131	0		
12th Avenue	9	NB	0	0	2559	116	0		
12th Avenue	9	SB	0	317	2308	0	0		5527

**New Jersey
2021 With-Action G6
AM Peak Hour**

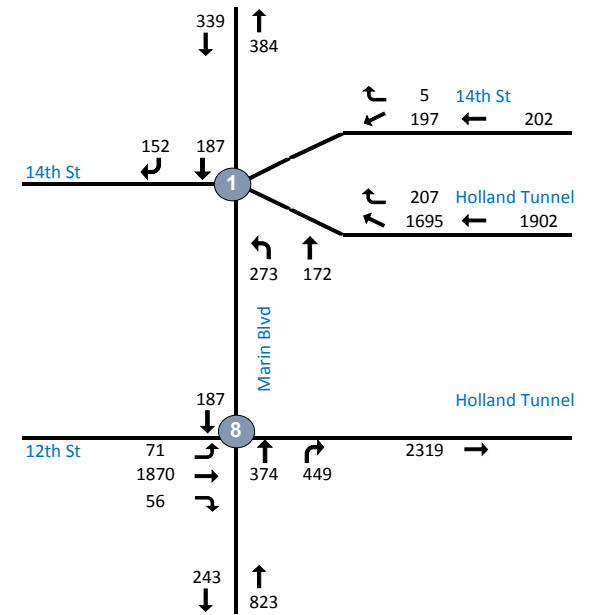
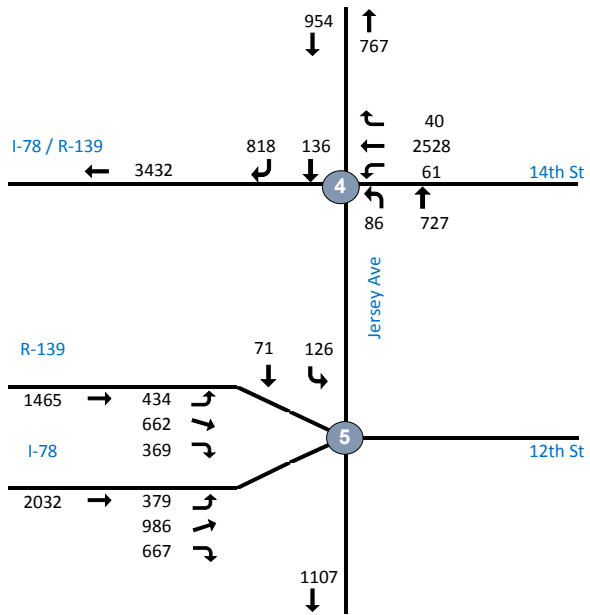

Intersection	Node	Approach	Total Vehicles						Total
			Inbound/Outbound						
			AM Peak Hour						
			L2	L	T	R	R2		
14th Street (E-W) & Jersey Avenue (N-S)									
NJ-TMC-007.xlsx									
n/a	4	EB	0	0	0	0	0		
14th Street	4	WB	0	61	2528	40	0		
Jersey Avenue	4	NB	0	86	727	0	0		
Jersey Avenue	4	SB	0	0	136	818	0	4396	
14th Street/Holland Tunnel (E-W) & Marin Boulevard (N-S)									
NJ-TMC-008.xlsx									
Holland Tunnel	1	WB	0	0	1695	207	0		
14th Street	1	SW	0	0	0	197	5		
Marin Boulevard	1	NB	0	273	172	0	0		
Marin Boulevard	1	SB	0	0	187	152	0	2888	
12th Street (E-W) & Jersey Avenue (N-S)									
NJ-TMC-009.xlsx	5								
R-139	5	SE	434	662	0	369	0		
I-78	5	EB	0	379	986	667	0		
Jersey Avenue	5	NB	0	0	0	0	0		
Jersey Avenue	5	SB	0	126	71	0	0	3694	
12th Street (E-W) & Marin Blvd (N-S)									
NJ-TMC-010.xlsx	8								
12th Street/Holland Tunnel	8	EB	0	71	1870	56	0		
n/a	8	WB	0	0	0	0	0		
Marin Boulevard	8	NB	0	0	374	449	0		
Marin Boulevard	8	SB	0	0	187	0	0	3007	

**New Jersey
2021 With-Action G6
MD Peak Hour**

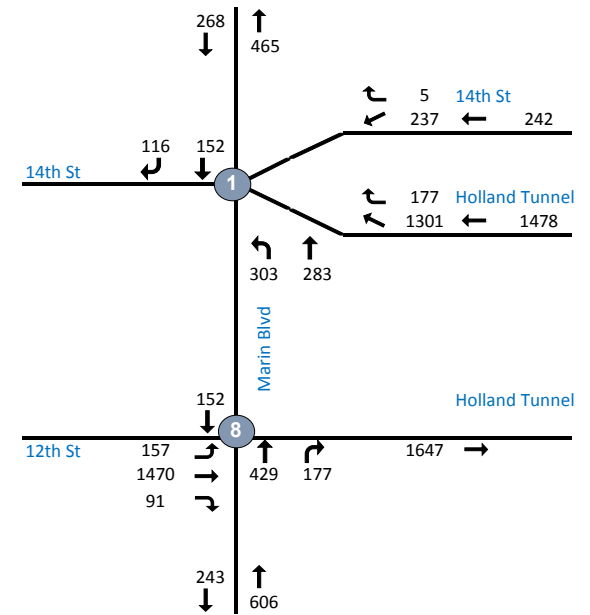
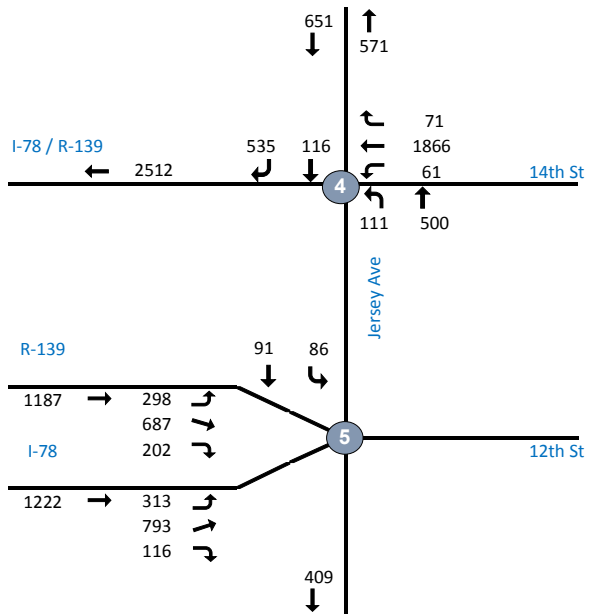

Intersection	Node	Approach	Total Vehicles						Total
			Inbound/Outbound						
			MD Peak Hour						
			L2	L	T	R	R2		
14th Street (E-W) & Jersey Avenue (N-S)									
NJ-TMC-007.xlsx									
n/a	4	EB	0	0	0	0	0		
14th Street	4	WB	0	61	1866	71	0		
Jersey Avenue	4	NB	0	111	500	0	0		
Jersey Avenue	4	SB	0	0	116	535	0	3260	
14th Street/Holland Tunnel (E-W) & Marin Boulevard (N-S)									
NJ-TMC-008.xlsx									
Holland Tunnel	1	WB	0	0	1301	177	0		
14th Street	1	SW	0	0	0	237	5		
Marin Boulevard	1	NB	0	303	283	0	0		
Marin Boulevard	1	SB	0	0	152	116	0	2574	
12th Street (E-W) & Jersey Avenue (N-S)									
NJ-TMC-009.xlsx	5								
R-139	5	SE	298	687	0	202	0		
I-78	5	EB	0	313	793	116	0		
Jersey Avenue	5	NB	0	0	0	0	0		
Jersey Avenue	5	SB	0	86	91	0	0	2586	
12th Street (E-W) & Marin Blvd (N-S)									
NJ-TMC-010.xlsx	8								
12th Street/Holland Tunnel	8	EB	0	157	1470	91	0		
n/a	8	WB	0	0	0	0	0		
Marin Boulevard	8	NB	0	0	429	177	0		
Marin Boulevard	8	SB	0	0	152	0	0	2476	

**New Jersey
2021 With-Action G6
PM Peak Hour**

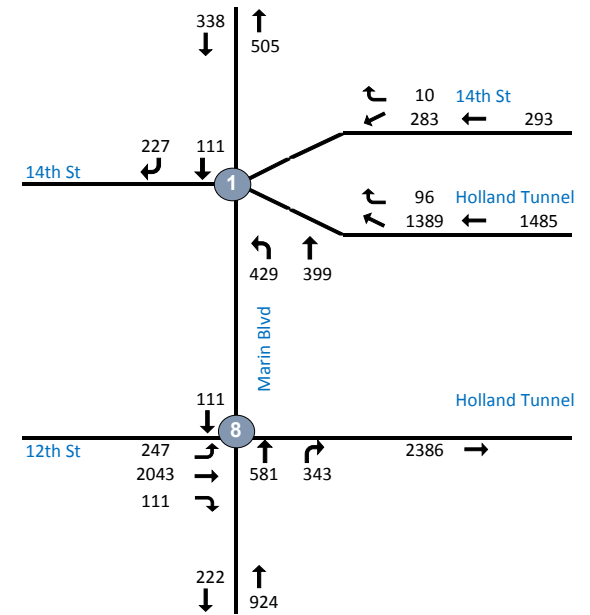
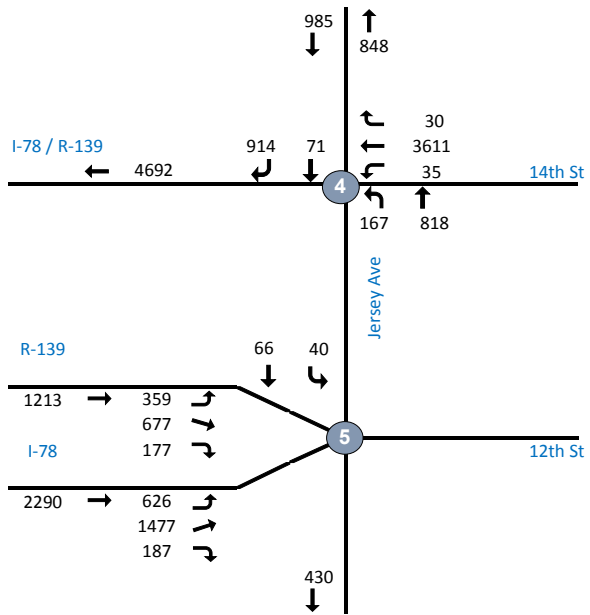

Intersection	Node	Approach	Total Vehicles						Total
			Inbound/Outbound						
			L2	L	T	R	R2		
14th Street (E-W) & Jersey Avenue (N-S)									
NJ-TMC-007.xlsx									
n/a	4	EB	0	0	0	0	0		
14th Street	4	WB	0	35	3611	30	0		
Jersey Avenue	4	NB	0	167	818	0	0		
Jersey Avenue	4	SB	0	0	71	914	0	5646	
14th Street/Holland Tunnel (E-W) & Marin Boulevard (N-S)									
NJ-TMC-008.xlsx									
Holland Tunnel	1	WB	0	0	1389	96	0		
14th Street	1	SW	0	0	0	283	10		
Marin Boulevard	1	NB	0	429	399	0	0		
Marin Boulevard	1	SB	0	0	111	227	0	2944	
12th Street (E-W) & Jersey Avenue (N-S)									
NJ-TMC-009.xlsx	5								
R-139	5	SE	359	677	0	177	0		
I-78	5	EB	0	626	1477	187	0		
Jersey Avenue	5	NB	0	0	0	0	0		
Jersey Avenue	5	SB	0	40	66	0	0	3609	
12th Street (E-W) & Marin Blvd (N-S)									
NJ-TMC-010.xlsx	8								
12th Street/Holland Tunnel	8	EB	0	247	2043	111	0		
n/a	8	WB	0	0	0	0	0		
Marin Boulevard	8	NB	0	0	581	343	0		
Marin Boulevard	8	SB	0	0	111	0	0	3436	

CBD Tolling
QMT - Traffic Flowmap
AM With-Action



- Legend:**
- 1 - Intersection (2019 Collected Data)
 - 7 - Intersection (Uncollected Data)
 - 100 - ATR Volume
 - 100 - Approach Volume

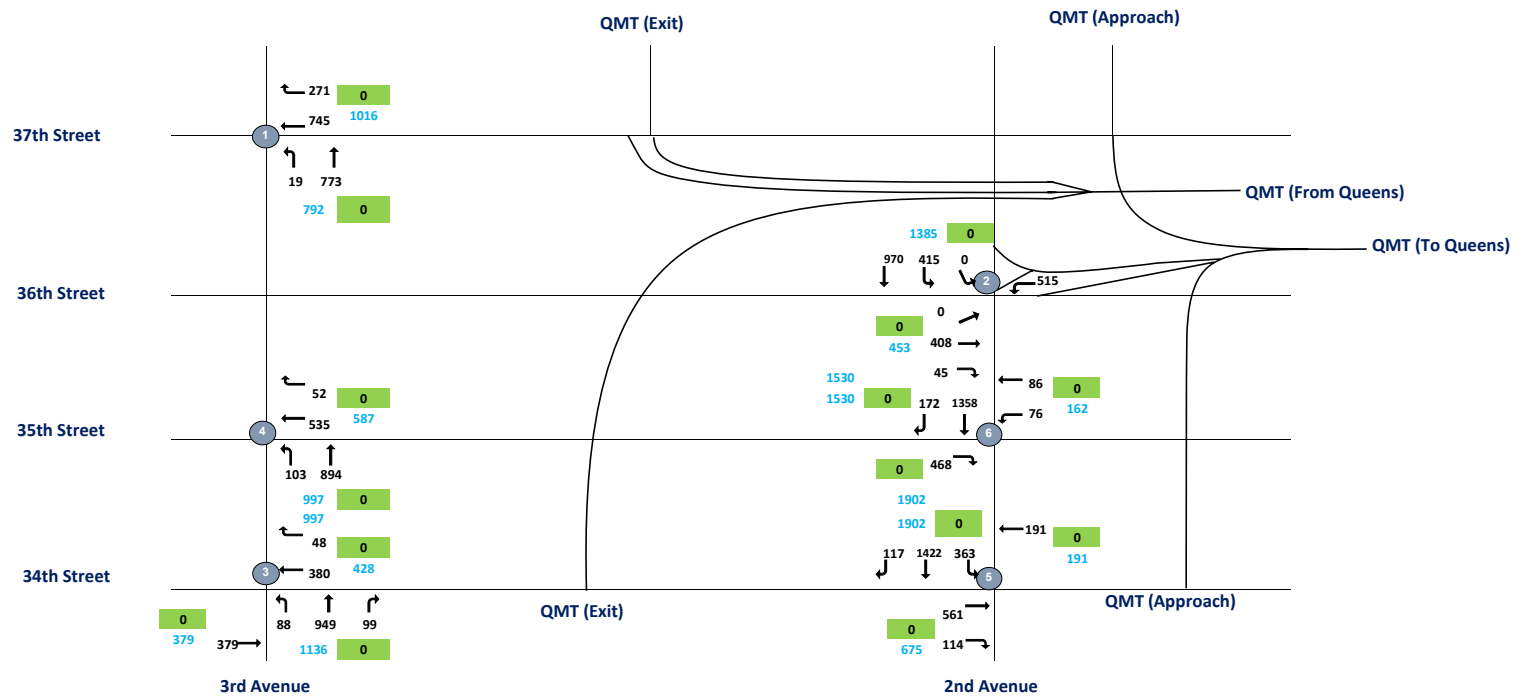

QM

8:00:00 AM

Intersection	Node	Approach	Total Vehicles					
			Inbound/Outbound					
			AM Peak Hour					
			L2	L	T	R	R2	Total
37th St & 3rd Ave 2019 (TMC-016)	1							
37th St	1	EB	0	0	0	0	0	
37th St	1	WB	0	0	745	271	0	
3rd Ave	1	NB	0	19	773	0	0	
3rd Ave	1	SB	0	0	0	0	0	1808
36th St & 2nd Ave 2019 (TMC-017)	2							
36th St	2	EB	0	0	408	45	0	
36th St	2	WB	0	515	0	0	0	
2nd Ave	2	NB	0	0	0	0	0	
2nd Ave	2	SB	0	415	970	0	0	2353
34th St & 3rd Ave 2019 (TMC-018)	3							
34th St	3	EB	0	0	379	0	0	
34th St	3	WB	0	0	380	48	0	
3rd Ave	3	NB	0	88	949	99	0	
3rd Ave	3	SB	0	0	0	0	0	1943
35th St & 3rd Ave 2019 (TMC-019)	4							
35th St	4	EB	0	0	0	0	0	
35th St	4	WB	0	0	535	52	0	
3rd Ave	4	NB	0	103	894	0	0	
3rd Ave	4	SB	0	0	0	0	0	1584
34th St & 2nd Ave 2019 (TMC-020)	5							
34th St	5	EB	0	0	561	114	0	
34th St	5	WB	0	0	191	0	0	
2nd Ave	5	NB	0	0	0	0	0	
2nd Ave	5	SB	0	363	1422	117	0	2768
35th St & 2nd Ave 2019 (TMC-021)	6							
35th St	6	EB	0	0	0	468	0	
35th St	6	WB	0	76	86	0	0	
2nd Ave	6	NB	0	0	0	0	0	
2nd Ave	6	SB	0	0	1358	172	0	2160

CBD Tolling
QMT - Traffic Flowmap
MD With-Action



- Legend:**
- 1 - Intersection (2019 Collected Data)
 - 7 - Intersection (Uncollected Data)
 - 100 - ATR Volume
 - 100 - Approach Volume

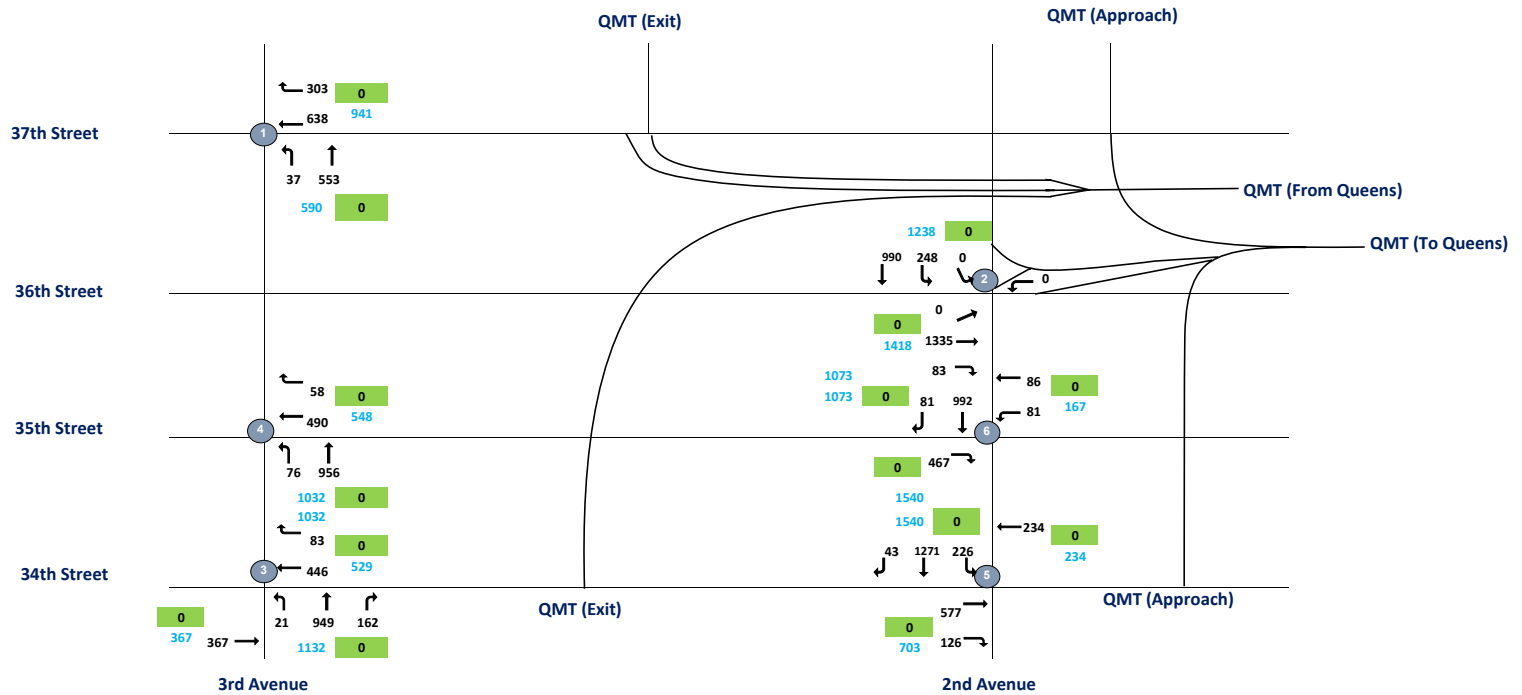

QM

1:00:00 PM

Intersection	Node	Approach	Total Vehicles						
			Inbound/Outbound						
			MD Peak Hour						
			L2	L	T	R	R2	Total	
37th St & 3rd Ave 2019 (TMC-016)	1								
37th St	1	EB	0	0	0	0	0		
37th St	1	WB	0	0	638	303	0		
3rd Ave	1	NB	0	37	553	0	0		
3rd Ave	1	SB	0	0	0	0	0		1531
36th St & 2nd Ave 2019 (TMC-017)	2								
36th St	2	EB	0	0	1335	83	0		
36th St	2	WB	0	0	0	0	0		
2nd Ave	2	NB	0	0	0	0	0		
2nd Ave	2	SB	0	248	990	0	0		2656
34th St & 3rd Ave 2019 (TMC-018)	3								
34th St	3	EB	0	0	367	0	0		
34th St	3	WB	0	0	446	83	0		
3rd Ave	3	NB	0	21	949	162	0		
	3	SB	0	0	0	0	0		2028
35th St & 3rd Ave 2019 (TMC-019)	4								
35th St	4	EB	0	0	0	0	0		
35th St	4	WB	0	0	490	58	0		
3rd Ave	4	NB	0	76	956	0	0		
	4	SB	0	0	0	0	0		1580
34th St & 2nd Ave 2019 (TMC-020)	5								
34th St	5	EB	0	0	577	126	0		
34th St	5	WB	0	0	234	0	0		
2nd Ave	5	NB	0	0	0	0	0		
2nd Ave	5	SB	0	226	1271	43	0		2477
35th St & 2nd Ave 2019 (TMC-021)	6								
35th St	6	EB	0	0	0	467	0		
35th St	6	WB	0	81	86	0	0		
2nd Ave	6	NB	0	0	0	0	0		
2nd Ave	6	SB	0	0	992	81	0		1707

CBD Tolling
QMT - Traffic Flowmap
PM With-Action



- Legend:**
- 1 - Intersection (2019 Collected Data)
 - 7 - Intersection (Uncollected Data)
 - 100 - ATR Volume
 - 100 - Approach Volume

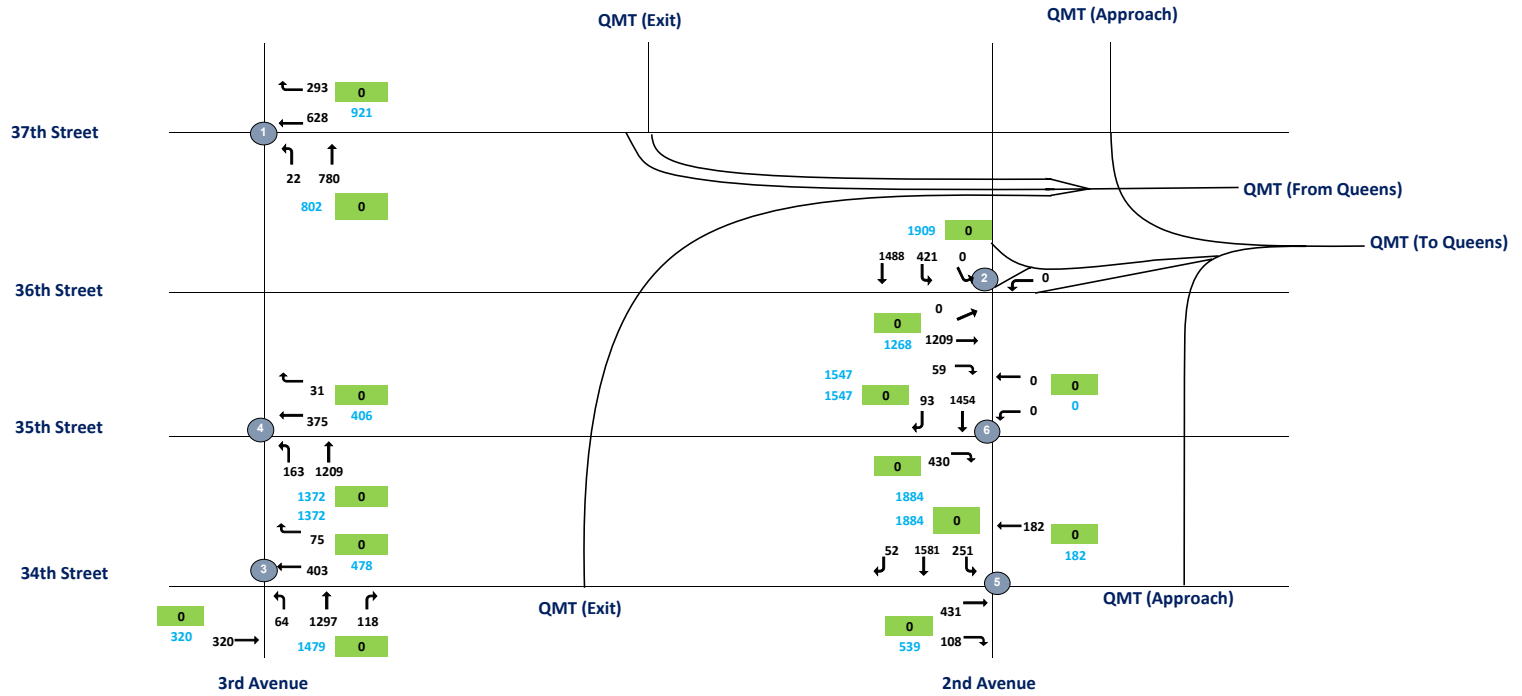

QM

5:00:00 PM

Intersection	Node	Approach	Total Vehicles					
			Inbound/Outbound					
			PM Peak Hour					
			L2	L	T	R	R2	Total
37th St & 3rd Ave 2019 (TMC-016)	1							
37th St	1	EB	0	0	0	0	0	
37th St	1	WB	0	0	628	293	0	
3rd Ave	1	NB	0	22	780	0	0	
3rd Ave	1	SB	0	0	0	0	0	1723
36th St & 2nd Ave 2019 (TMC-017)	2							
36th St	2	EB	0	0	1209	59	0	
36th St	2	WB	0	0	0	0	0	
2nd Ave	2	NB	0	0	0	0	0	
2nd Ave	2	SB	0	421	1488	0	0	3177
34th St & 3rd Ave 2019 (TMC-018)	3							
34th St	3	EB	0	0	320	0	0	
34th St	3	WB	0	0	403	75	0	
3rd Ave	3	NB	0	64	1297	118	0	
3rd Ave	3	SB	0	0	0	0	0	2277
35th St & 3rd Ave 2019 (TMC-019)	4							
35th St	4	EB	0	0	0	0	0	
35th St	4	WB	0	0	375	31	0	
3rd Ave	4	NB	0	163	1209	0	0	
3rd Ave	4	SB	0	0	0	0	0	1778
34th St & 2nd Ave 2019 (TMC-020)	5							
34th St	5	EB	0	0	431	108	0	
34th St	5	WB	0	0	182	0	0	
2nd Ave	5	NB	0	0	0	0	0	
2nd Ave	5	SB	0	251	1581	52	0	2605
35th St & 2nd Ave 2019 (TMC-021)	6							
35th St	6	EB	0	0	0	430	0	
35th St	6	WB	0	0	0	0	0	
2nd Ave	6	NB	0	0	0	0	0	
2nd Ave	6	SB	0	0	1454	93	0	1977

CBD Tolling
QMT - Traffic Flowmap
LN With-Action



- Legend:**
- 1 - Intersection (2019 Collected Data)
 - 7 - Intersection (Uncollected Data)
 - 100 - ATR Volume
 - 100 - Approach Volume

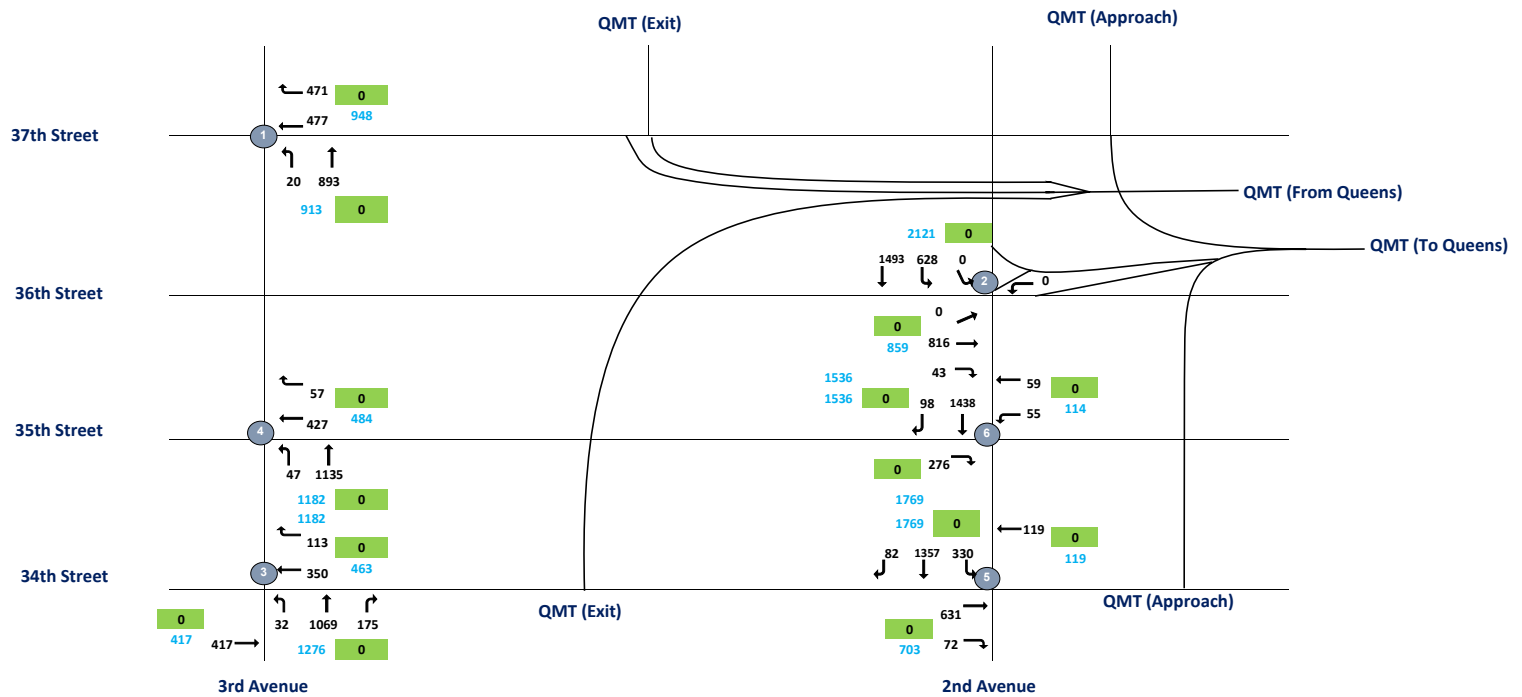





QM

9:00:00 PM

Intersection	Node	Approach	Total Vehicles					
			Inbound/Outbound					
			LN Peak Hour					
			L2	L	T	R	R2	Total
37th St & 3rd Ave 2019 (TMC-016)	1							
37th St	1	EB	0	0	0	0	0	
37th St	1	WB	0	0	477	471	0	
3rd Ave	1	NB	0	20	893	0	0	
3rd Ave	1	SB	0	0	0	0	0	1861
36th St & 2nd Ave 2019 (TMC-017)	2							
36th St	2	EB	0	0	816	43	0	
36th St	2	WB	0	0	0	0	0	
2nd Ave	2	NB	0	0	0	0	0	
2nd Ave	2	SB	0	628	1493	0	0	2980
34th St & 3rd Ave 2019 (TMC-018)	3							
34th St	3	EB	0	0	417	0	0	
34th St	3	WB	0	0	350	113	0	
3rd Ave	3	NB	0	32	1069	175	0	
	3	SB	0	0	0	0	0	2156
35th St & 3rd Ave 2019 (TMC-019)	4							
35th St	4	EB	0	0	0	0	0	
35th St	4	WB	0	0	427	57	0	
3rd Ave	4	NB	0	47	1135	0	0	
	4	SB	0	0	0	0	0	1666
34th St & 2nd Ave 2019 (TMC-020)	5							
34th St	5	EB	0	0	631	72	0	
34th St	5	WB	0	0	119	0	0	
2nd Ave	5	NB	0	0	0	0	0	
2nd Ave	5	SB	0	330	1357	82	0	2591
35th St & 2nd Ave 2019 (TMC-021)	6							
35th St	6	EB	0	0	0	276	0	
35th St	6	WB	0	55	59	0	0	
2nd Ave	6	NB	0	0	0	0	0	
2nd Ave	6	SB	0	0	1438	98	0	1926

CBD Tolling
RKB - Traffic Flowmap
AM With-Action



- Legend:**
-  - Intersection (2019 Collected Data)
 -  - Intersection (Uncollected Data)
 -  - ATR Volume
 -  - Approach Volume

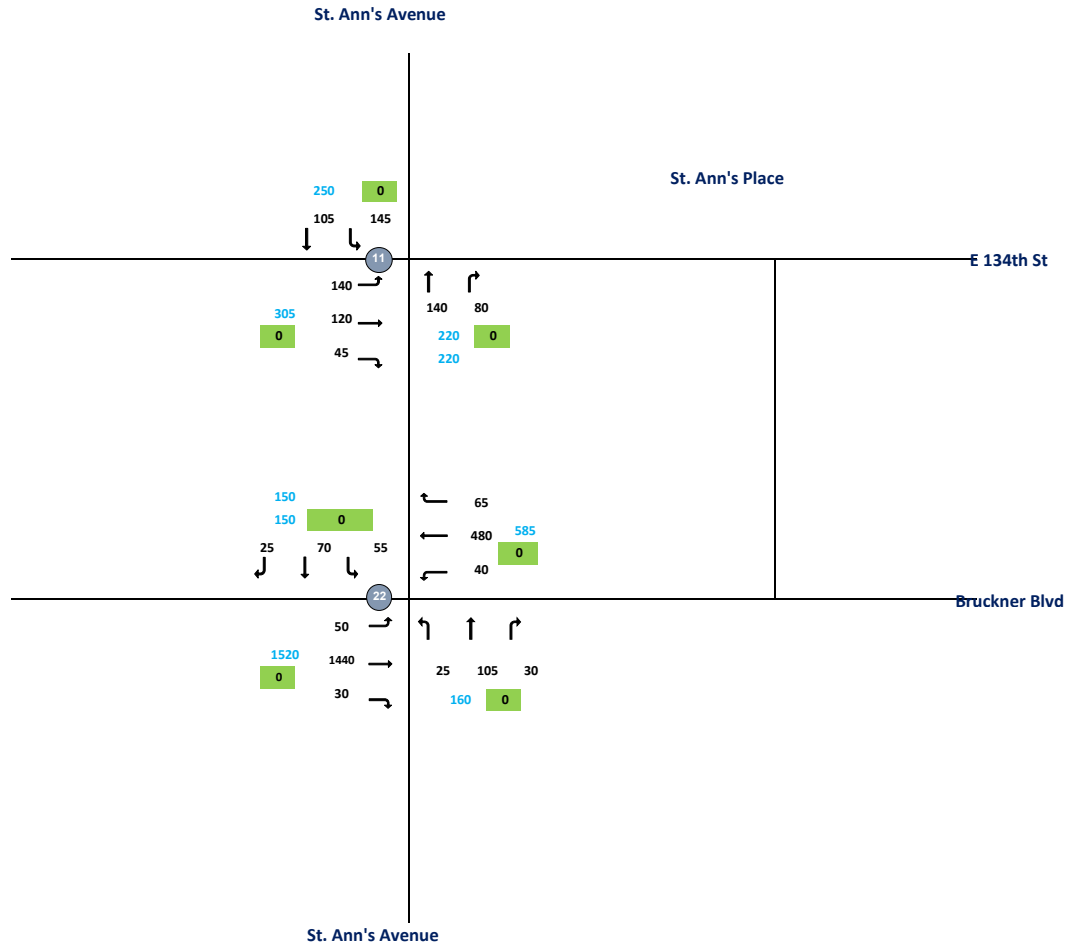

RKB

8:00 AM

Intersection	Node	Approach	Total Vehicles					
			Inbound/Outbound					Total
			AM Peak Hour					
L2	L	T	R	R2	Total			
E 134th Street and St. Ann's Ave 2019 (TMC-060)	11							
E 134th Street	11	EB	0	140	120	45	0	
E 134th Street	11	WB	0	0	0	0	0	
St. Ann's Ave	11	NB	0	0	140	80	0	
St. Ann's Ave	11	SB	0	145	105	0	0	775
Bruckner Blvd and St. Ann's Ave 2019 (TMC-061)	22							
Bruckner Blvd	22	EB	0	50	1440	30	0	
Bruckner Blvd	22	WB	0	40	480	65	0	
St. Ann's Ave	22	NB	0	25	105	30	0	
St. Ann's Ave	22	SB	0	55	70	25	0	2415

CBD Tolling
AS - Traffic Flowmap
AM With-Action



- Legend:**
- 1 - Intersection (2019 Collected Data)
 - 7 - Intersection (Uncollected Data)
 - 100 - ATR Volume
 - 100 - Approach Volume

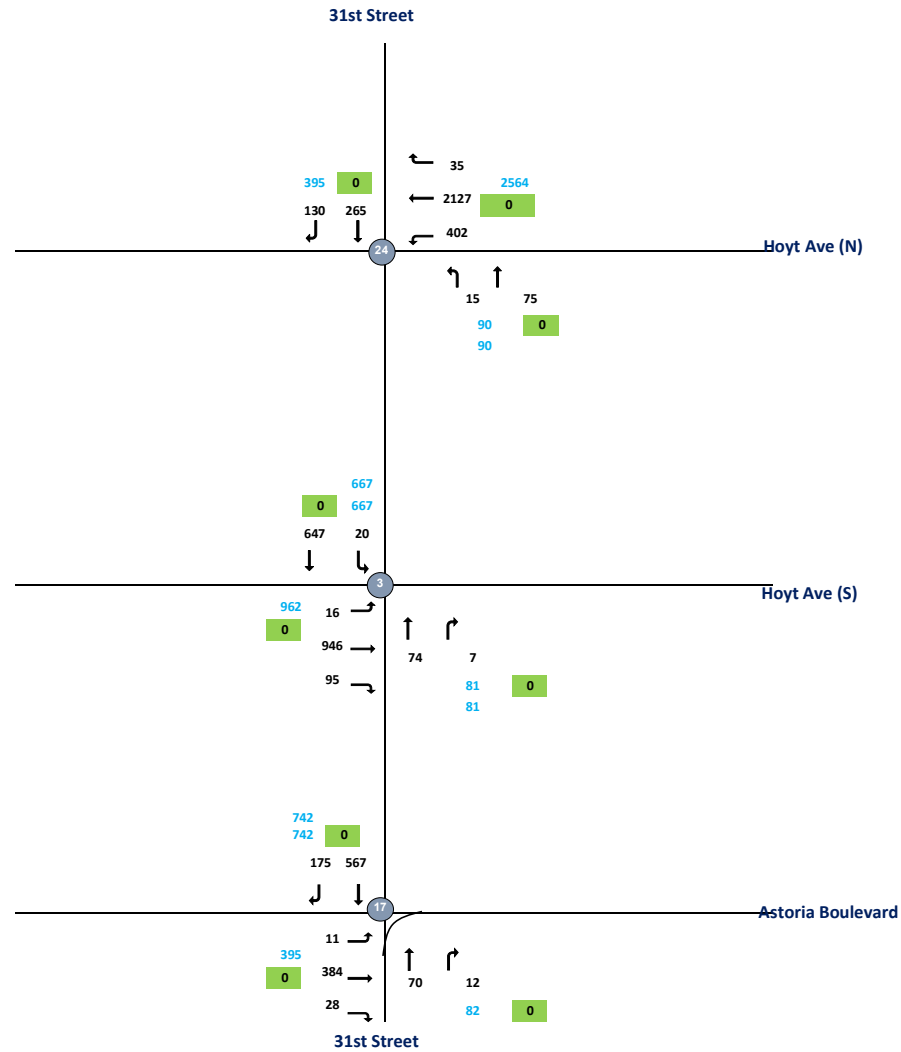

AS

7:15:00 AM

Intersection	Node	Approach	Total Vehicles						
			Inbound/Outbound						
			AM Peak Hour						
			L2	L	T	R	R2	Total	
31st Street and Astoria Blvd 2019 (TMC-062)	17								
Astoria Blvd	17	EB	0	11	384	28	0		
Astoria Blvd	17	WB	0	0	0	0	0		
31st Street	17	NB	0	0	70	12	0		
31st Street	17	SB	0	0	567	175	0		1247
31st Street and Hoyt Ave N 2019 (TMC-063)	24								
Hoyt Ave N	24	EB	0	0	0	0	0		
Hoyt Ave N	24	WB	0	402	2127	35	0		
31st Street	24	NB	0	15	75	0	0		
31st Street	24	SB	0	0	265	130	0		3049
31st Street and Hoyt Ave S 2019 (TMC-064)	3								
Hoyt Ave S	3	EB	0	16	946	95	0		
	3		0	0	0	0	0		
31st Street	3	NB	0	0	74	7	0		
31st Street	3	SB	0	20	647	0	0		1805

CBD Tolling
RKM - Traffic Flowmap
AM With-Action



- Legend:**
- 1 - Intersection (2019 Collected Data)
 - 2 - Intersection (Uncollected Data)
 - 100 - ATR Volume
 - 100 - Approach Volume

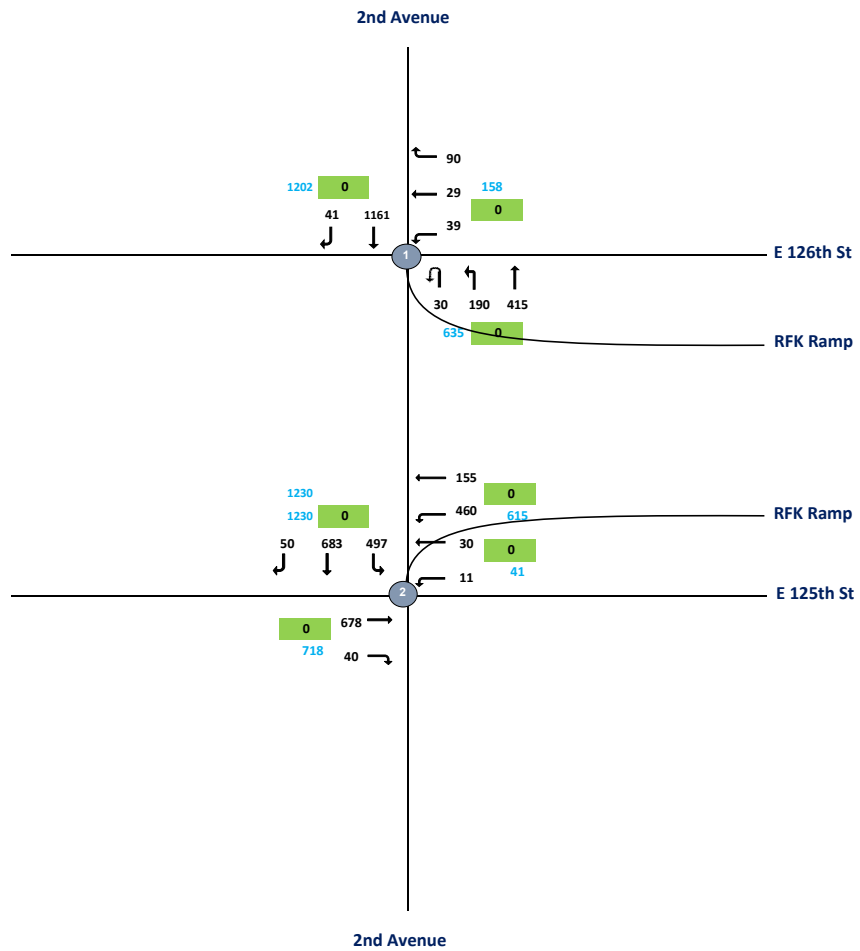

RKM

7:45 AM

Intersection	Node	Approach	Total Vehicles						Total
			Inbound/Outbound						
			AM Peak Hour						
			L2	L	T	R	R2		
E 126th Street and 2nd Ave									
2019 (TMC-058)									
RFK Ramp	1	NW	30	190	0	415	0		
E 126th Street	1	EB	0	0	0	0	0		
E 126th Street	1	WB	0	39	29	90	0		
2nd Ave	1	NB	0	0	0	0	0		
2nd Ave	1	SB	0	0	1161	41	0	1360	
E 125th Street and 2nd Ave									
2019 (TMC-059)									
E 125th Street	2	EB	0	0	678	40	0		
E 125th Street	2	WB	0	11	30	0	0		
2nd Ave	2	SW	0	460	0	155	0		
2nd Ave	2	SB	0	497	683	50	0	2604	

CBD Tolling
RKB - Traffic Flowmap
MD With-Action



- Legend:**
- ① - Intersection (2019 Collected Data)
 - ⑦ - Intersection (Uncollected Data)
 - 100 - ATR Volume
 - 100 - Approach Volume

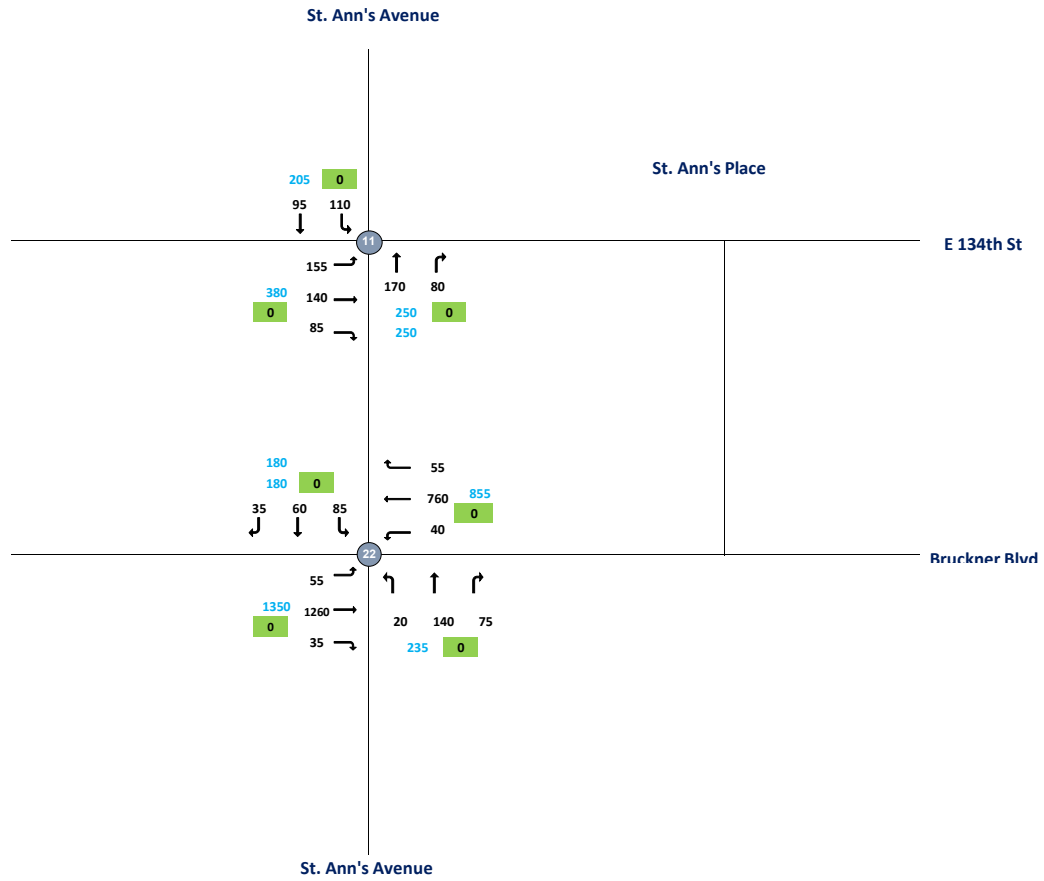

RKB

1:00 PM

Intersection	Node	Approach	Total Vehicles						
			Inbound/Outbound						
			MD Peak Hour						
			L2	L	T	R	R2	Total	
E 134th Street and St. Ann's Ave 2019 (TMC-060)	11								
E 134th Street	11	EB	0	155	140	85	0		
E 134th Street	11	WB	0	0	0	0	0		
St. Ann's Ave	11	NB	0	0	170	80	0		
St. Ann's Ave	11	SB	0	110	95	0	0	835	
Bruckner Blvd and St. Ann's Ave 2019 (TMC-061)	22								
Bruckner Blvd	22	EB	0	55	1260	35	0		
Bruckner Blvd	22	WB	0	40	760	55	0		
St. Ann's Ave	22	NB	0	20	140	75	0		
St. Ann's Ave	22	SB	0	85	60	35	0	2620	

CBD Tolling
AS - Traffic Flowmap
MD With-Action



- Legend:**
- 1 - Intersection (2019 Collected Data)
 - 7 - Intersection (Uncollected Data)
 - 100 - ATR Volume
 - 100 - Approach Volume

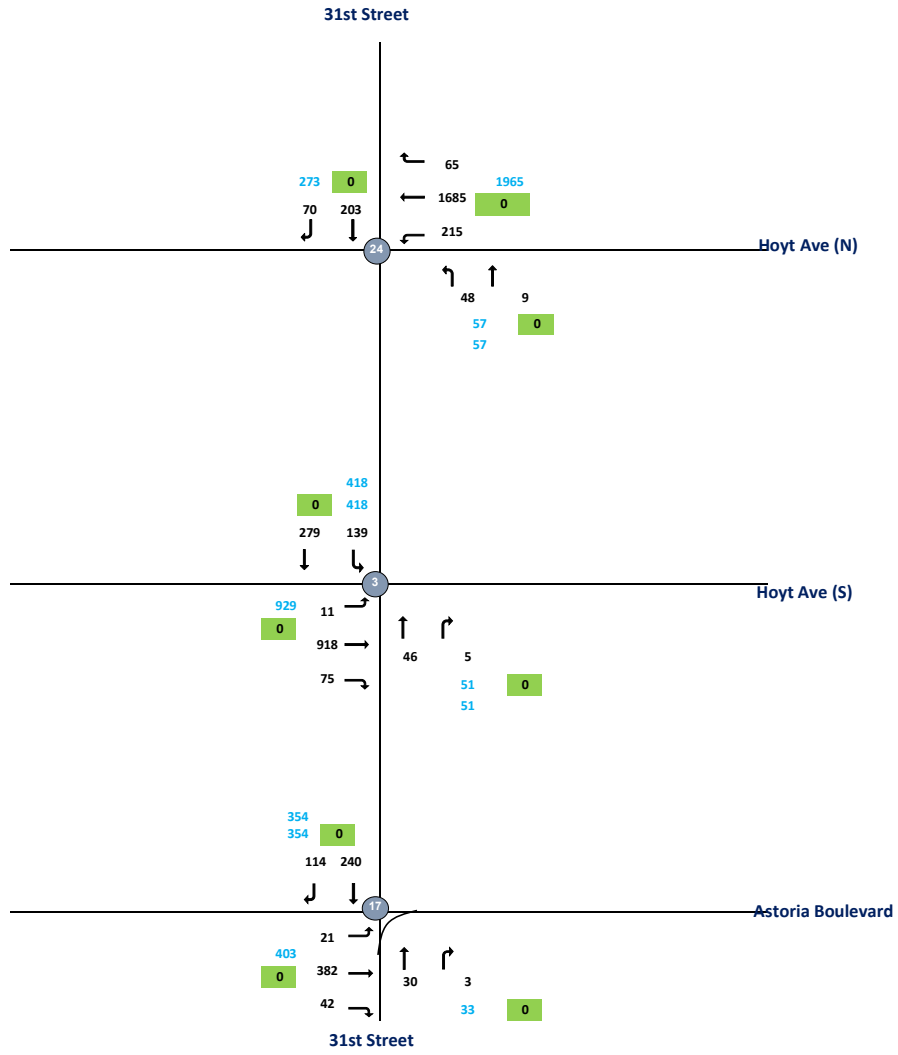

AS

12:30:00 PM

Intersection	Node	Approach	Total Vehicles					
			Inbound/Outbound					
			MD Peak Hour					
			L2	L	T	R	R2	Total
31st Street and Astoria Blvd 2019 (TMC-062)	17							
Astoria Blvd	17	EB	0	21	382	42	0	
Astoria Blvd	17	WB	0	0	0	0	0	
31st Street	17	NB	0	0	30	3	0	
31st Street	17	SB	0	0	240	114	0	832
31st Street and Hoyt Ave N 2019 (TMC-063)	24							
Hoyt Ave N	24	EB	0	0	0	0	0	
Hoyt Ave N	24	WB	0	215	1685	65	0	
31st Street	24	NB	0	48	9	0	0	
31st Street	24	SB	0	0	203	70	0	2295
31st Street and Hoyt Ave S 2019 (TMC-064)	3							
Hoyt Ave S	3	EB	0	11	918	75	0	
	3		0	0	0	0	0	
31st Street	3	NB	0	0	46	5	0	
31st Street	3	SB	0	139	279	0	0	1473

CBD Tolling
RKM - Traffic Flowmap
MD With-Action



- Legend:**
- 1 - Intersection (2019 Collected Data)
 - 7 - Intersection (Uncollected Data)
 - 100 - ATR Volume
 - 100 - Approach Volume

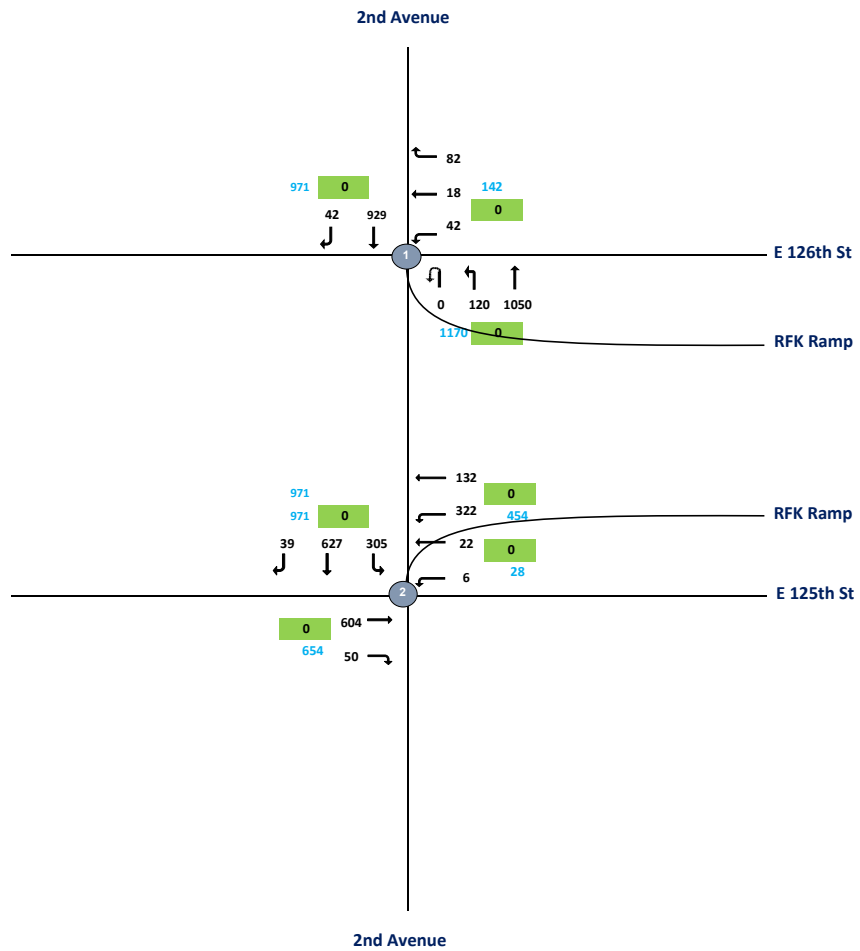

RKM

1:00 PM

Intersection	Node	Approach	Total Vehicles					
			Inbound/Outbound					Total
			MD Peak Hour					
L2	L	T	R	R2				
E 126th Street and 2nd Ave 2019 (TMC-058)								
RFK Ramp	1	NW	0	120	0	1050	0	
E 126th Street	1	EB	0	0	0	0	0	
E 126th Street	1	WB	0	42	18	82	0	
2nd Ave	1	NB	0	0	0	0	0	
2nd Ave	1	SB	0	0	929	42	0	1113
E 125th Street and 2nd Ave 2019 (TMC-059)	2							
E 125th Street	2	EB	0	0	604	50	0	
E 125th Street	2	WB	0	6	22	0	0	
2nd Ave	2	SW	0	322	0	132	0	
2nd Ave	2	SB	0	305	627	39	0	2107

CBD Tolling
RKB - Traffic Flowmap
PM With-Action



- Legend:**
- Intersection (2019 Collected Data)
 - Intersection (Uncollected Data)
 - 100 - ATR Volume
 - 100 - Approach Volume

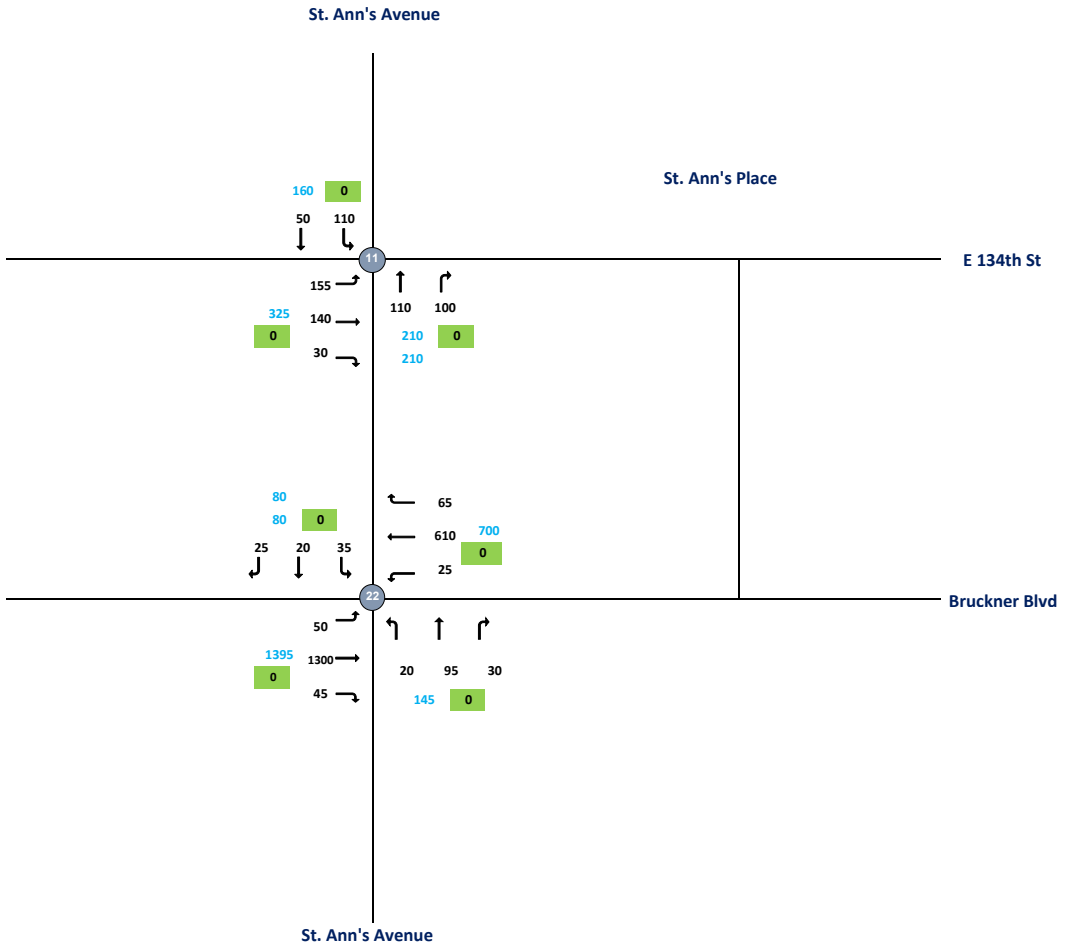

RKB

5:00 PM

Intersection	Node	Approach	Total Vehicles					
			Inbound/Outbound					
			PM Peak Hour					
			L2	L	T	R	R2	Total
E 134th Street and St. Ann's Ave								
2019 (TMC-060)								
E 134th Street	11	EB	0	155	140	30	0	
E 134th Street	11	WB	0	0	0	0	0	
St. Ann's Ave	11	NB	0	0	110	100	0	
St. Ann's Ave	11	SB	0	110	50	0	0	695
Bruckner Blvd and St. Ann's Ave								
2019 (TMC-061)								
Bruckner Blvd	22	EB	0	50	1300	45	0	
Bruckner Blvd	22	WB	0	25	610	65	0	
St. Ann's Ave	22	NB	0	20	95	30	0	
St. Ann's Ave	22	SB	0	35	20	25	0	2320

CBD Tolling
AS - Traffic Flowmap
PM With-Action



- Legend:**
- 1 - Intersection (2019 Collected Data)
 - 7 - Intersection (Uncollected Data)
 - 100 - ATR Volume
 - 100 - Approach Volume

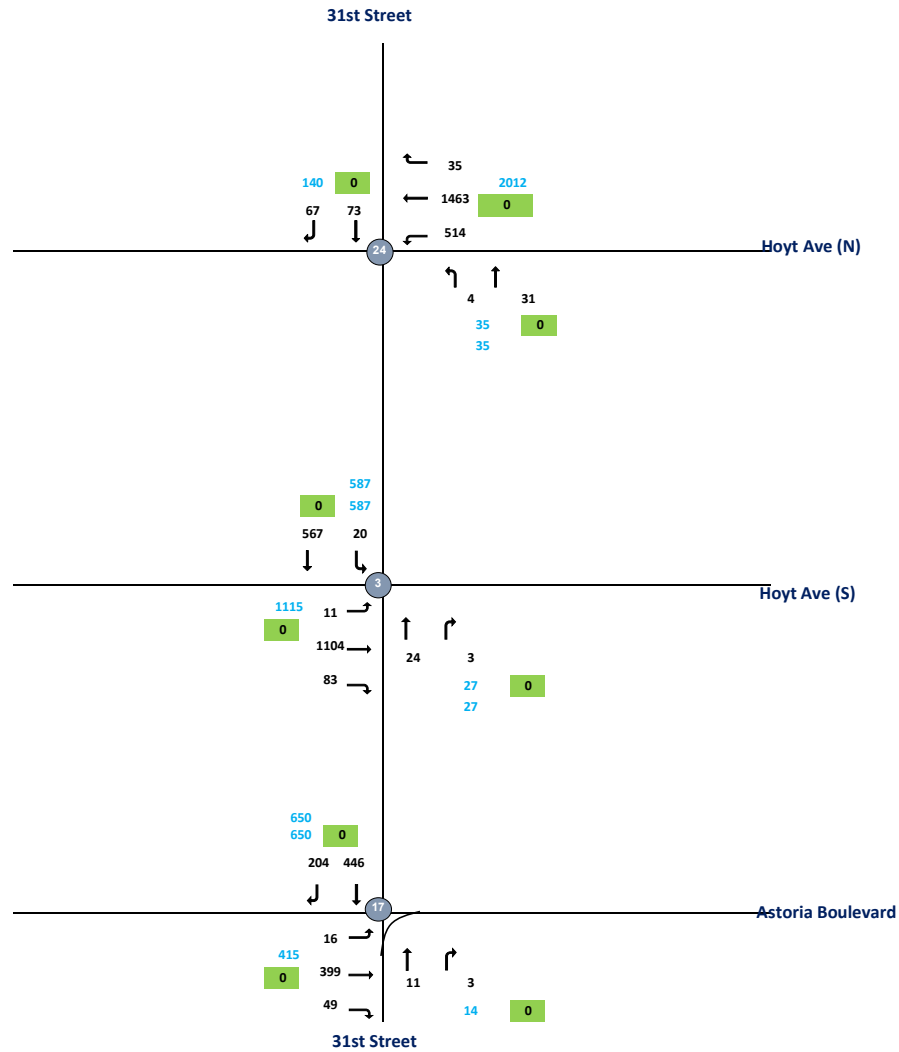

AS

5:00:00 PM

Intersection	Node	Approach	Total Vehicles					
			Inbound/Outbound					
			PM Peak Hour					
			L2	L	T	R	R2	Total
31st Street and Astoria Blvd 2019 (TMC-062)	17							
Astoria Blvd	17	EB	0	16	399	49	0	
Astoria Blvd	17	WB	0	0	0	0	0	
31st Street	17	NB	0	0	11	3	0	
31st Street	17	SB	0	0	446	204	0	1128
31st Street and Hoyt Ave N 2019 (TMC-063)	24							
Hoyt Ave N	24	EB	0	0	0	0	0	
Hoyt Ave N	24	WB	0	514	1463	35	0	
31st Street	24	NB	0	4	31	0	0	
31st Street	24	SB	0	0	73	67	0	2187
31st Street and Hoyt Ave S 2019 (TMC-064)	3							
Hoyt Ave S	3	EB	0	11	1104	83	0	
	3		0	0	0	0	0	
31st Street	3	NB	0	0	24	3	0	
31st Street	3	SB	0	20	567	0	0	1812

CBD Tolling
RKM - Traffic Flowmap
PM With-Action



- Legend:**
- Intersection (2019 Collected Data)
 - Intersection (Uncollected Data)
 - 100** - ATR Volume
 - 100** - Approach Volume

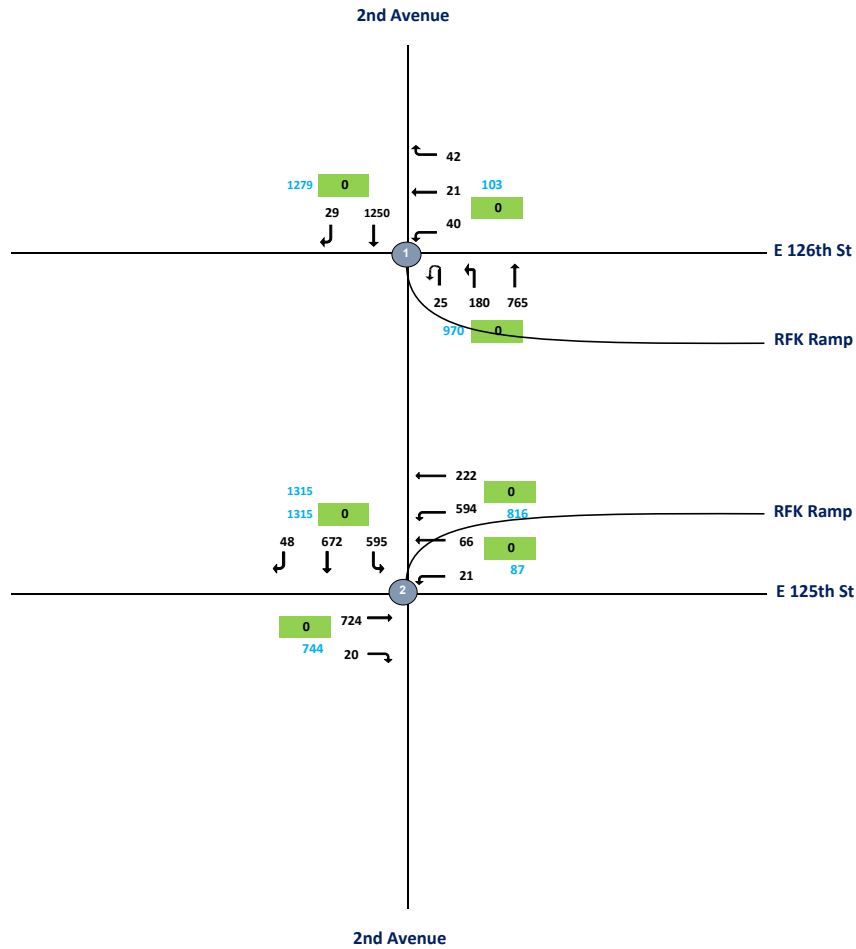

RKM

5:00 PM

Intersection	Node	Approach	Total Vehicles						Total
			Inbound/Outbound						
			PM Peak Hour						
			L2	L	T	R	R2		
E 126th Street and 2nd Ave 2019 (TMC-058)									
RFK Ramp	1	NW	25	180	0	765	0		
E 126th Street	1	EB	0	0	0	0	0		
E 126th Street	1	WB	0	40	21	42	0		
2nd Ave	1	NB	0	0	0	0	0		
2nd Ave	1	SB	0	0	1250	29	0	1382	
E 125th Street and 2nd Ave 2019 (TMC-059)	2								
E 125th Street	2	EB	0	0	724	20	0		
E 125th Street	2	WB	0	21	66	0	0		
2nd Ave	2	SW	0	594	0	222	0		
2nd Ave	2	SB	0	595	672	48	0	2962	

CBD Tolling
RKB - Traffic Flowmap
LN With-Action



- Legend:**
- Intersection (2019 Collected Data)
 - Intersection (Uncollected Data)
 - 100 - ATR Volume
 - 100 - Approach Volume

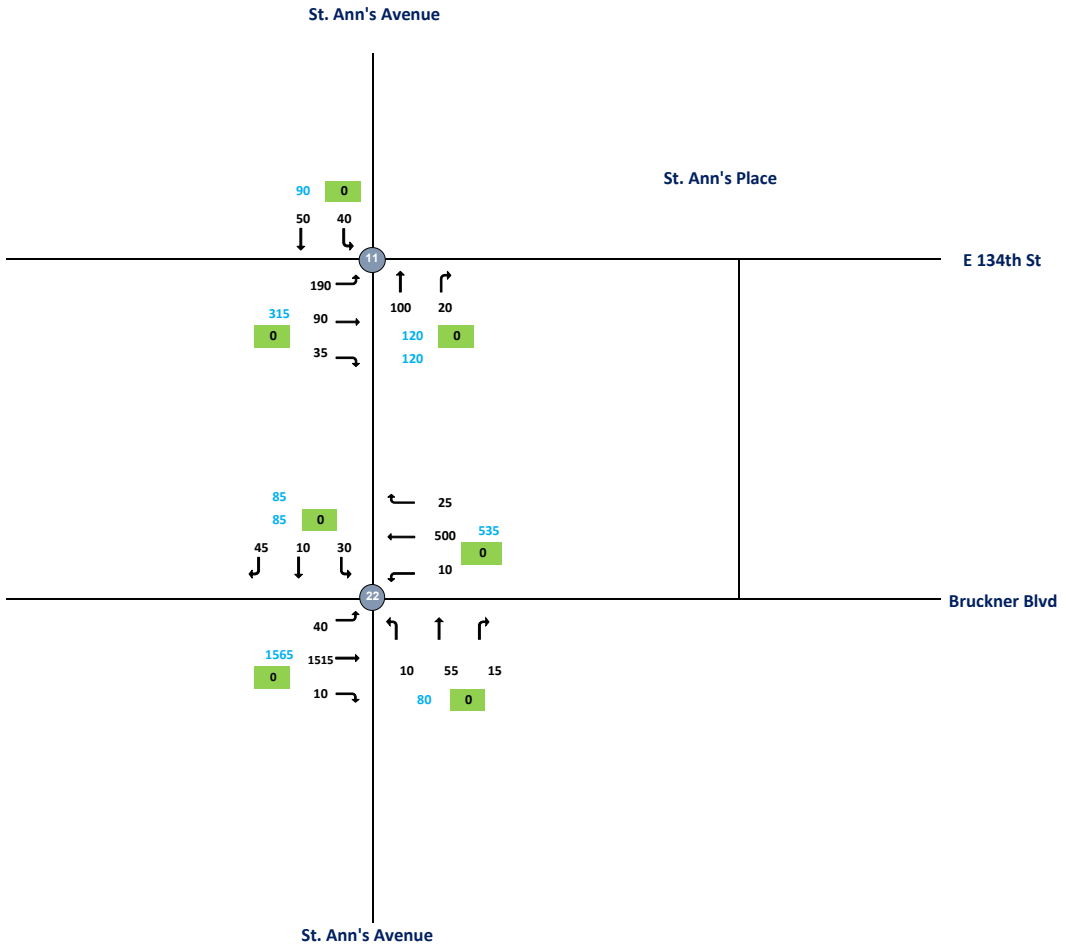

RKB

9:00 PM

Intersection	Node	Approach	Total Vehicles					
			Inbound/Outbound					Total
			L2	L	T	R	R2	
E 134th Street and St. Ann's Ave 2019 (TMC-060)	11							
E 134th Street	11	EB	0	190	90	35	0	
E 134th Street	11	WB	0	0	0	0	0	
St. Ann's Ave	11	NB	0	0	100	20	0	
St. Ann's Ave	11	SB	0	40	50	0	0	525
Bruckner Blvd and St. Ann's Ave 2019 (TMC-061)	22							
Bruckner Blvd	22	EB	0	40	1515	10	0	
Bruckner Blvd	22	WB	0	10	500	25	0	
St. Ann's Ave	22	NB	0	10	55	15	0	
St. Ann's Ave	22	SB	0	30	10	45	0	2265

CBD Tolling
AS - Traffic Flowmap
LN With-Action



- Legend:**
- 1 - Intersection (2019 Collected Data)
 - 7 - Intersection (Uncollected Data)
 - 100 - ATR Volume
 - 100 - Approach Volume

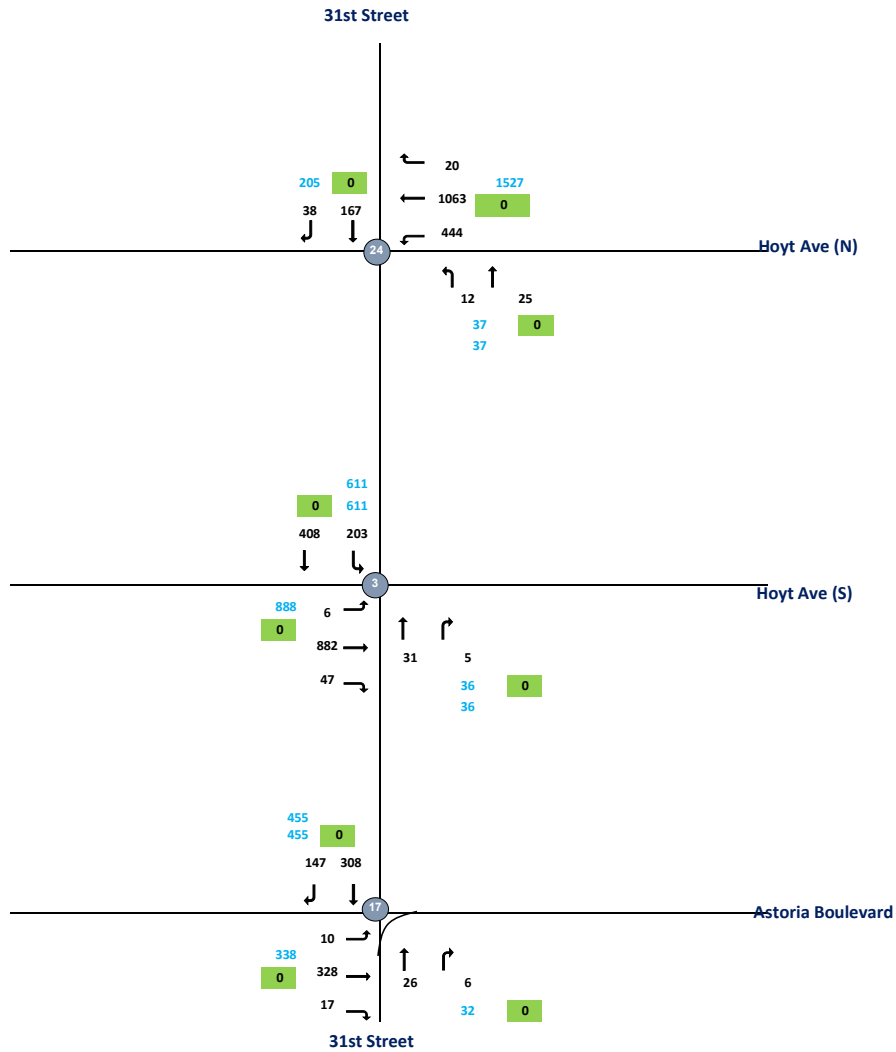

AS

9:00:00 PM

Intersection	Node	Approach	Total Vehicles					
			Inbound/Outbound					
			LN Peak Hour					
			L2	L	T	R	R2	Total
31st Street and Astoria Blvd 2019 (TMC-062)	17							
Astoria Blvd	17	EB	0	10	328	17	0	
Astoria Blvd	17	WB	0	0	0	0	0	
31st Street	17	NB	0	0	26	6	0	
31st Street	17	SB	0	0	308	147	0	842
31st Street and Hoyt Ave N 2019 (TMC-063)	24							
Hoyt Ave N	24	EB	0	0	0	0	0	
Hoyt Ave N	24	WB	0	444	1063	20	0	
31st Street	24	NB	0	12	25	0	0	
31st Street	24	SB	0	0	167	38	0	1769
31st Street and Hoyt Ave S 2019 (TMC-064)	3							
Hoyt Ave S	3	EB	0	6	882	47	0	
	3		0	0	0	0	0	
31st Street	3	NB	0	0	31	5	0	
31st Street	3	SB	0	203	408	0	0	1582

CBD Tolling
RKM - Traffic Flowmap
LN With-Action



- Legend:**
- Intersection (2019 Collected Data)
 - Intersection (Uncollected Data)
 - ATR Volume
 - Approach Volume

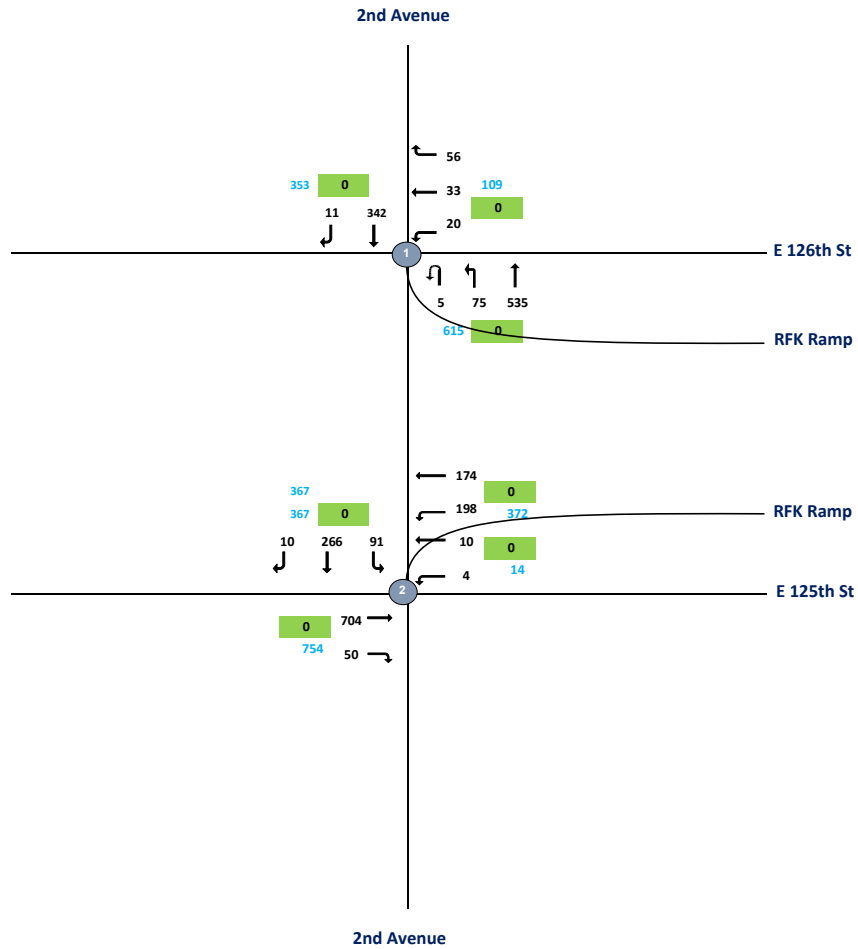

RKM

9:00 PM

Intersection	Node	Approach	Total Vehicles						Total
			Inbound/Outbound						
			LN Peak Hour						
			L2	L	T	R	R2		
E 126th Street and 2nd Ave									
2019 (TMC-058)									
RFK Ramp	1	NW	5	75	0	535	0		
E 126th Street	1	EB	0	0	0	0	0		
E 126th Street	1	WB	0	20	33	56	0		
2nd Ave	1	NB	0	0	0	0	0		
2nd Ave	1	SB	0	0	342	11	0	462	
E 125th Street and 2nd Ave									
2019 (TMC-059)									
E 125th Street	2	EB	0	0	704	50	0		
E 125th Street	2	WB	0	4	10	0	0		
2nd Ave	2	SW	0	198	0	174	0		
2nd Ave	2	SB	0	91	266	10	0	1507	

CBD Tolling
Red Hook- Traffic Flowmap
AM With-Action



- Legend:**
- 1 - Intersection (2019 Collected Data)
 - 7 - Intersection (Uncollected Data)
 - 100 - ATR Volume
 - 100 - Approach Volume

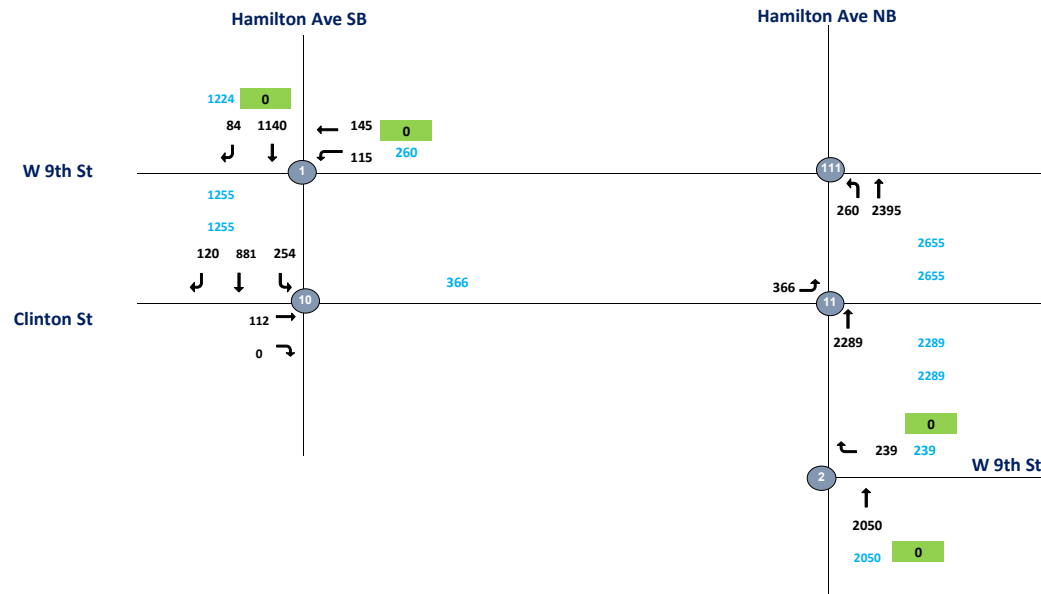

RH

7:45:00 AM

Intersection	Node	Approach	Total Vehicles					Total
			Inbound/Outbound					
			AM Peak Hour					
			L2	L	T	R	R2	
Hamilton Ave SB & W 9th St 2019 (TMC-040)	1							
W 9th St	1	EB	0	0	0	0	0	
W 9th St	1	WB	0	115	145	0	0	
Hamilton Ave SB	1		0	0	0	0	0	
Hamilton Ave SB	1	SB	0	0	1140	84	0	1484
Hamilton Ave SB & W 9th St 2019 (TMC-040)	10							
Clinton Avenue	10	EB	0	0	112	0	0	
Clinton Avenue	10	WB	0	0	0	0	0	
Hamilton Ave SB	10		0	0	0	0	0	
Hamilton Ave SB	10	SB	0	254	881	120	0	1367
Hamilton Ave SB & W 9th St 2019 (TMC-040)	11							
Clinton Avenue	11	EB	0	366	0	0	0	
Clinton Avenue	11		0	0	0	0	0	
Hamilton Ave	11	NB	0	0	2289	0	0	
Hamilton Ave	11		0	0	0	0	0	2655
Hamilton Ave SB & W 9th St 2019 (TMC-040)	111							
W 9th St	111	EB	0	0	0	0	0	
W 9th St	111	WB	0	0	0	0	0	
Hamilton Ave	111	NB	0	260	2395	0	0	
-	111	SB	0	0	0	0	0	2655
Hamilton Ave NB & W 9th St 2019 (TMC-041)	2							
W 9th St	2	EB	0	0	0	0	0	
W 9th St	2	WB	0	0	0	239	0	
Hamilton Ave	2	NB	0	0	2050	0	0	
Hamilton Ave	2	SB	0	0	0	0	0	2289

CBD Tolling
Red Hook- Traffic Flowmap
MD With-Action



- Legend:**
- 1 - Intersection (2019 Collected Data)
 - 7 - Intersection (Uncollected Data)
 - 100 - ATR Volume
 - 100 - Approach Volume

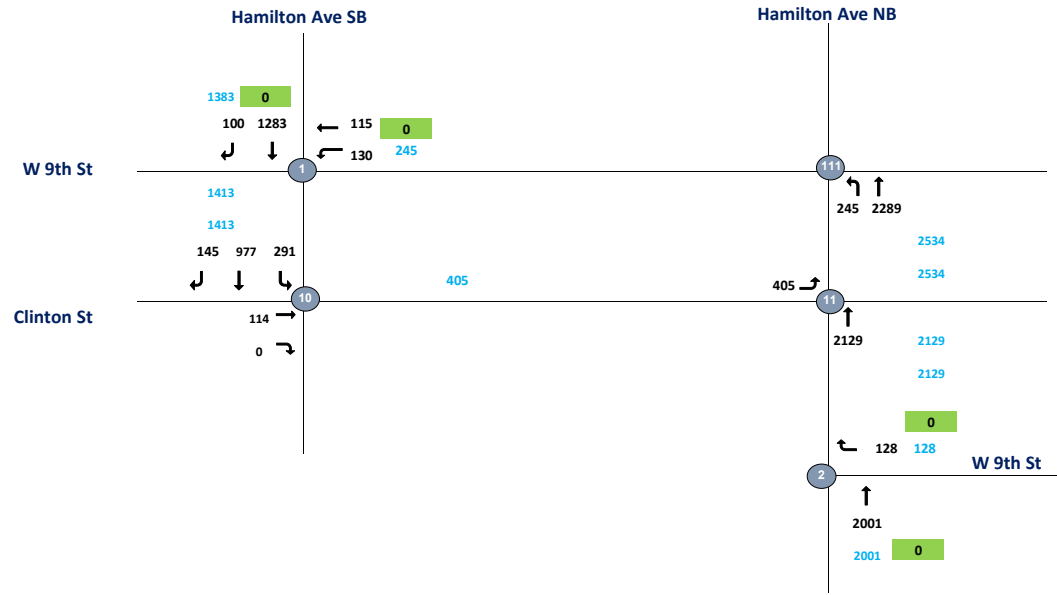

RH

12:00:00 PM

Intersection	Node	Approach	Total Vehicles					Total
			Inbound/Outbound					
			MD Peak Hour					
			L2	L	T	R	R2	
Hamilton Ave SB & W 9th St 2019 (TMC-040)	1							
W 9th St	1	EB	0	0	0	0	0	
W 9th St	1	WB	0	130	115	0	0	
Hamilton Ave SB	1		0	0	0	0	0	
Hamilton Ave SB	1	SB	0	0	1283	100	0	1628
Hamilton Ave SB & W 9th St 2019 (TMC-040)	10							
Clinton Avenue	10	EB	0	0	114	0	0	
Clinton Avenue	10	WB	0	0	0	0	0	
Hamilton Ave SB	10		0	0	0	0	0	
Hamilton Ave SB	10	SB	0	291	977	145	0	1527
Hamilton Ave SB & W 9th St 2019 (TMC-040)	11							
Clinton Avenue	11	EB	0	405	0	0	0	
Clinton Avenue	11		0	0	0	0	0	
Hamilton Ave	11	NB	0	0	2129	0	0	
Hamilton Ave	11		0	0	0	0	0	2534
Hamilton Ave SB & W 9th St 2019 (TMC-040)	111							
W 9th St	111	EB	0	0	0	0	0	
W 9th St	111	WB	0	0	0	0	0	
Hamilton Ave	111	NB	0	245	2289	0	0	
-	111	SB	0	0	0	0	0	2534
Hamilton Ave NB & W 9th St 2019 (TMC-041)	2							
W 9th St	2	EB	0	0	0	0	0	
W 9th St	2	WB	0	0	0	128	0	
Hamilton Ave	2	NB	0	0	2001	0	0	
Hamilton Ave	2	SB	0	0	0	0	0	2129

CBD Tolling
Red Hook- Traffic Flowmap
PM With-Action



- Legend:**
- 1 - Intersection (2019 Collected Data)
 - 7 - Intersection (Uncollected Data)
 - 100 - ATR Volume
 - 100 - Approach Volume

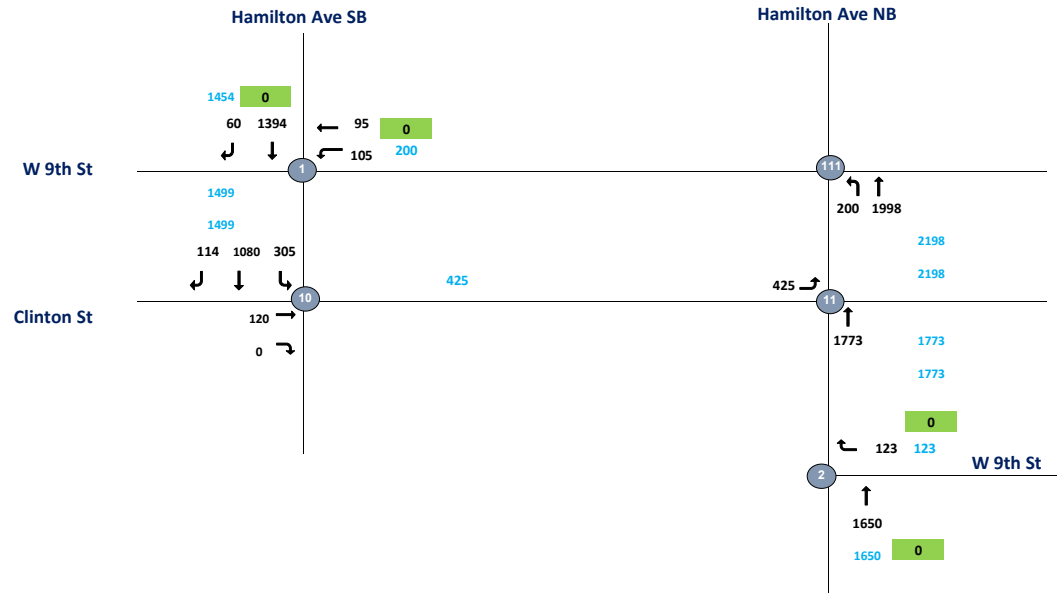

RH

4:00:00 PM

Intersection	Node	Approach	Total Vehicles					Total
			Inbound/Outbound					
			PM Peak Hour					
			L2	L	T	R	R2	
Hamilton Ave SB & W 9th St 2019 (TMC-040)	1							
W 9th St	1	EB	0	0	0	0	0	
W 9th St	1	WB	0	105	95	0	0	
Hamilton Ave SB	1		0	0	0	0	0	
Hamilton Ave SB	1	SB	0	0	1394	60	0	1654
Hamilton Ave SB & W 9th St 2019 (TMC-040)	10							
Clinton Avenue	10	EB	0	0	120	0	0	
Clinton Avenue	10	WB	0	0	0	0	0	
Hamilton Ave SB	10		0	0	0	0	0	
Hamilton Ave SB	10	SB	0	305	1080	114	0	1619
Hamilton Ave SB & W 9th St 2019 (TMC-040)	11							
Clinton Avenue	11	EB	0	425	0	0	0	
Clinton Avenue	11		0	0	0	0	0	
Hamilton Ave	11	NB	0	0	1773	0	0	
Hamilton Ave	11		0	0	0	0	0	2198
Hamilton Ave SB & W 9th St 2019 (TMC-040)	111							
W 9th St	111	EB	0	0	0	0	0	
W 9th St	111	WB	0	0	0	0	0	
Hamilton Ave	111	NB	0	200	1998	0	0	
-	111	SB	0	0	0	0	0	2198
Hamilton Ave NB & W 9th St 2019 (TMC-041)	2							
W 9th St	2	EB	0	0	0	0	0	
W 9th St	2	WB	0	0	0	123	0	
Hamilton Ave	2	NB	0	0	1650	0	0	
Hamilton Ave	2	SB	0	0	0	0	0	1773

CBD Tolling
Red Hook- Traffic Flowmap
LN With-Action



- Legend:**
- 1 - Intersection (2019 Collected Data)
 - 7 - Intersection (Uncollected Data)
 - 100 - ATR Volume
 - 100 - Approach Volume

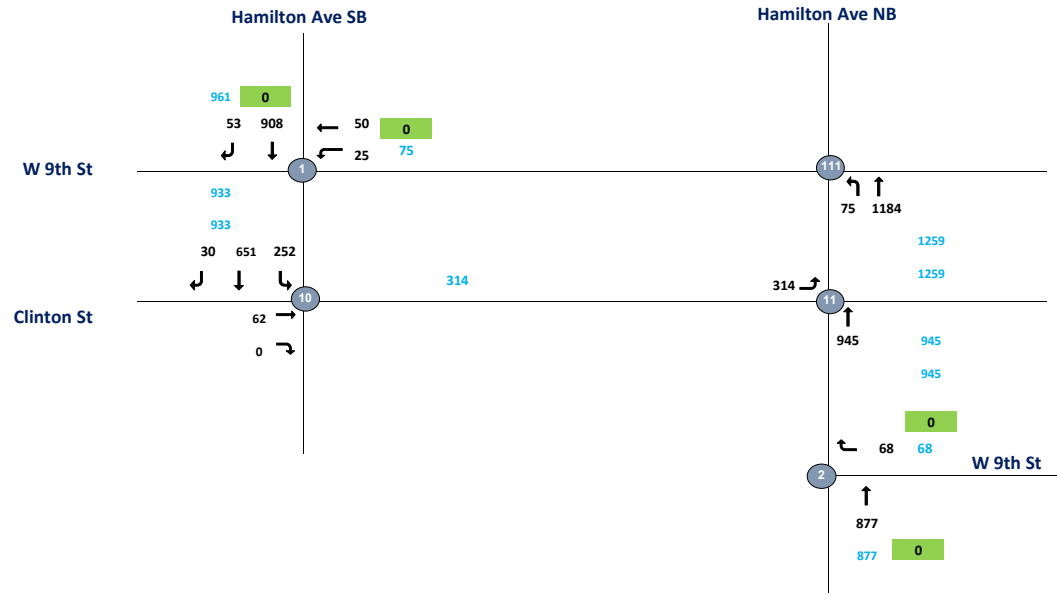

RH

9:00:00 PM

Intersection	Node	Approach	Total Vehicles					Total
			Inbound/Outbound					
			LN Peak Hour					
			L2	L	T	R	R2	
Hamilton Ave SB & W 9th St 2019 (TMC-040)	1							
W 9th St	1	EB	0	0	0	0	0	
W 9th St	1	WB	0	25	50	0	0	
Hamilton Ave SB	1		0	0	0	0	0	
Hamilton Ave SB	1	SB	0	0	908	53	0	1036
Hamilton Ave SB & W 9th St 2019 (TMC-040)	10							
Clinton Avenue	10	EB	0	0	62	0	0	
Clinton Avenue	10	WB	0	0	0	0	0	
Hamilton Ave SB	10		0	0	0	0	0	
Hamilton Ave SB	10	SB	0	252	651	30	0	995
Hamilton Ave SB & W 9th St 2019 (TMC-040)	11							
Clinton Avenue	11	EB	0	314	0	0	0	
Clinton Avenue	11		0	0	0	0	0	
Hamilton Ave	11	NB	0	0	945	0	0	
Hamilton Ave	11		0	0	0	0	0	1259
Hamilton Ave SB & W 9th St 2019 (TMC-040)	111							
W 9th St	111	EB	0	0	0	0	0	
W 9th St	111	WB	0	0	0	0	0	
Hamilton Ave	111	NB	0	75	1184	0	0	
-	111	SB	0	0	0	0	0	1259
Hamilton Ave NB & W 9th St 2019 (TMC-041)	2							
W 9th St	2	EB	0	0	0	0	0	
W 9th St	2	WB	0	0	0	68	0	
Hamilton Ave	2	NB	0	0	877	0	0	
Hamilton Ave	2	SB	0	0	0	0	0	945

CBD Tolling
UE #1 - Traffic Flowmap
AM With Action



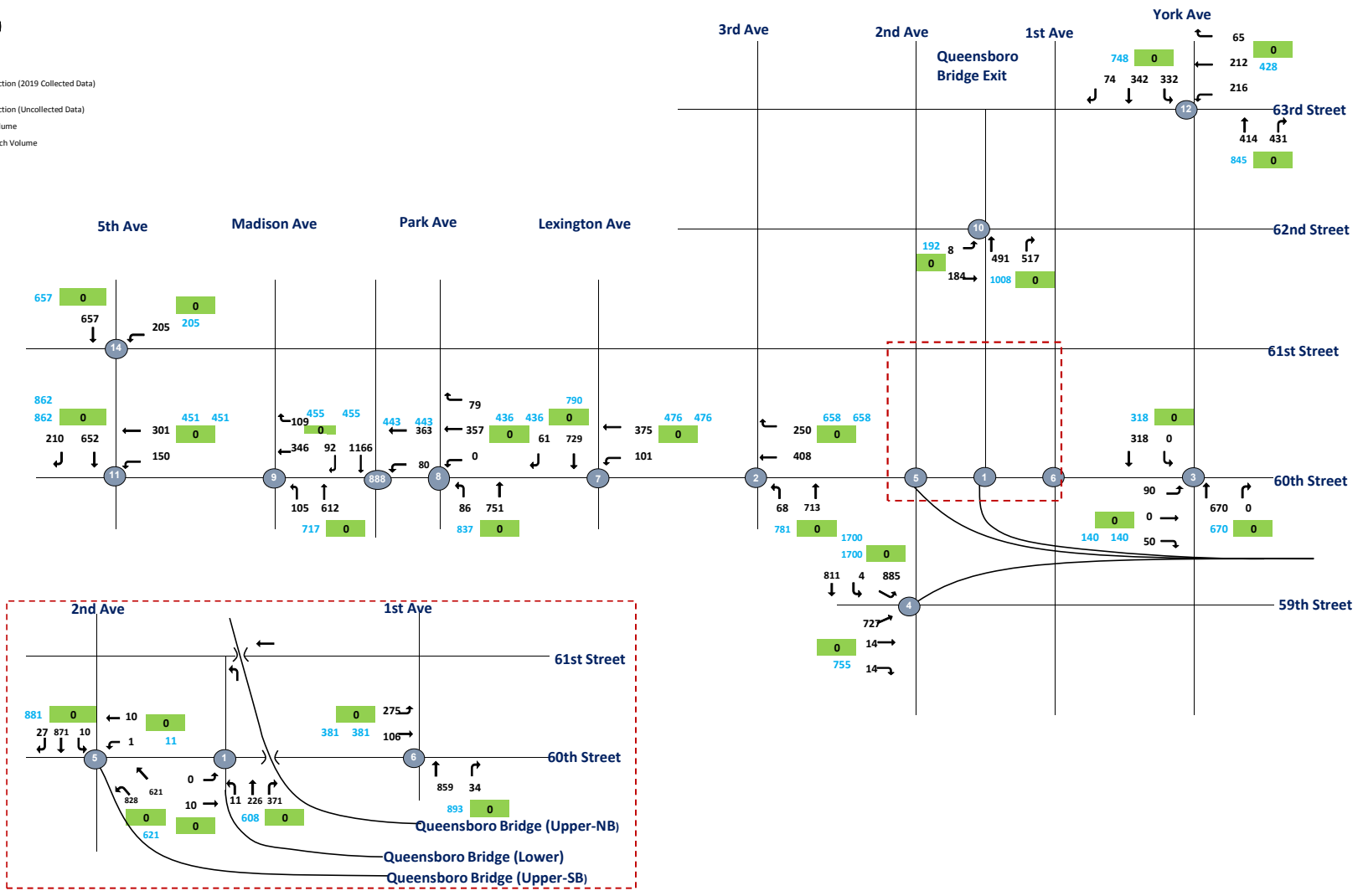

Legend:

- ① - Intersection (2019 Collected Data)
- ⑦ - Intersection (Uncollected Data)
- 100 - ATR Volume
- 100 - Approach Volume



CBD Tolling
UE #2 - Traffic Flowmap
AM With Action



- Legend:**
-  - Intersection (2019 Collected Data)
 -  - Intersection (Uncollected Data)
 -  - ATR Volume
 -  - Approach Volume

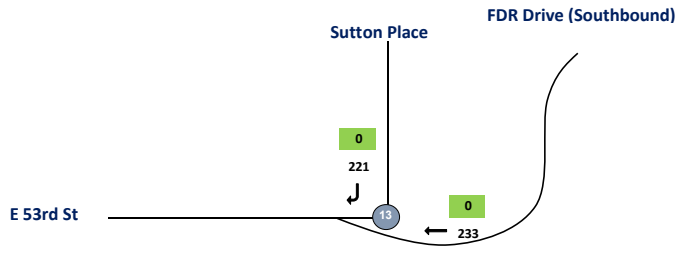

CBD Tolling
UE #3 - Traffic Flowmap
AM With Action



- Legend:**
- 1 - Intersection (2019 Collected Data)
 - 7 - Intersection (Uncollected Data)
 - 100 - ATR Volume
 - 100 - Approach Volume

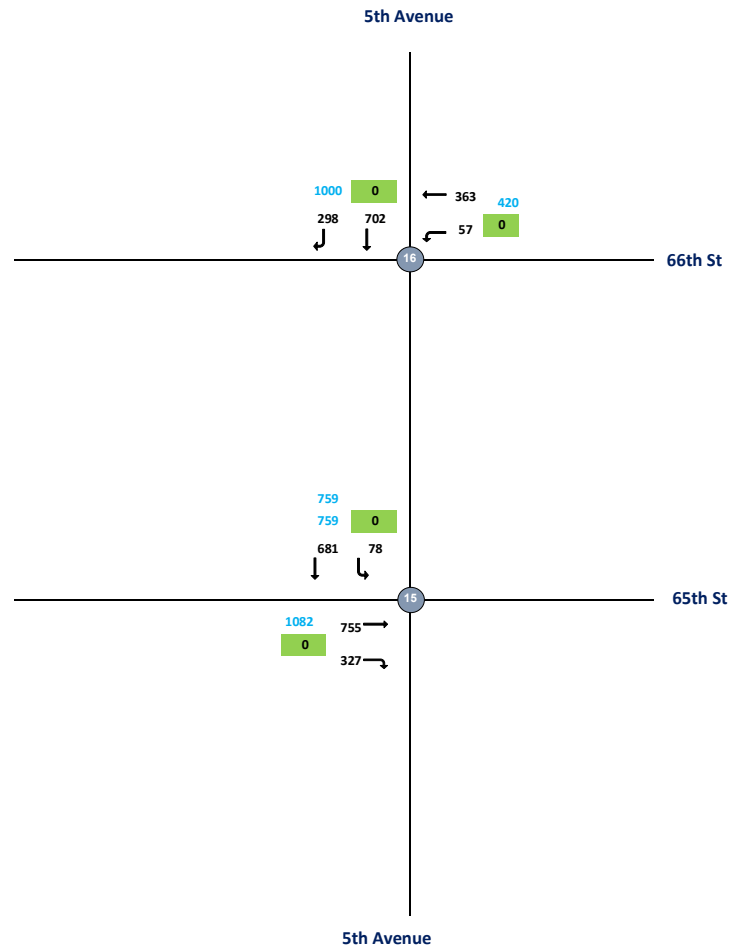

CBD Tolling
UE #3 - Traffic Flowmap
AM With Action



- Legend:**
- Intersection (2019 Collected Data)
 - Intersection (Uncollected Data)
 - 100 - ATR Volume
 - 100 - Approach Volume

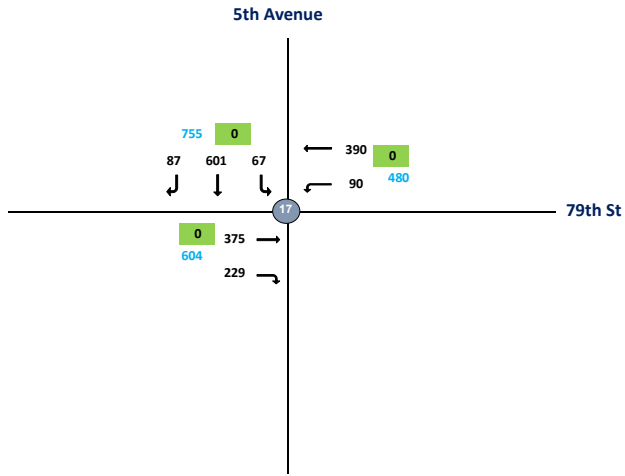

CBD Tolling
UE #4 - Traffic Flowmap
AM With Action



- Legend:**
- Intersection (2019 Collected Data)
 - Intersection (Uncollected Data)
 - 100 - ATR Volume
 - 100 - Approach Volume

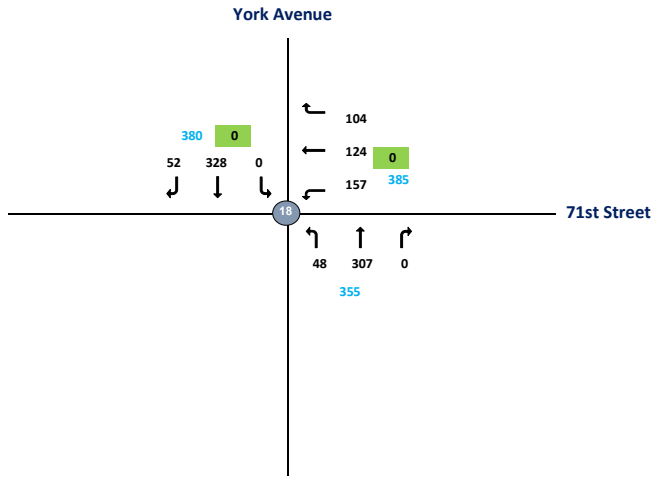

UE

8:00:00 AM

Intersection	Node	Approach	Total Vehicles					
			Inbound/Outbound					
			AM Peak Hour					
			L2	L	T	R	R2	Total
60th Street & Queensboro Bridge Exit								
2019 (TMC-022)	1							
60th Street	1	EB	0	0	10	0	0	
60th Street	1	WB	0	0	0	0	0	
Queensboro Bridge Exit	1	NB	0	11	226	371	0	
	1	SB	0	0	0	0	0	618
60th Street & 3rd Ave								
2019 (TMC-023)	2							
60th Street	2	EB	0	0	0	0	0	
60th Street	2	WB	0	0	408	250	0	
3rd Ave	2	NB	0	68	713	0	0	
	2	SB	0	0	0	0	0	1439
60th St & York Ave								
2019 (TMC-024)	3							
60th St	3	EB	0	90	0	50	0	
60th St	3	WB	0	0	0	0	0	
York Ave	3	NB	0	0	670	0	0	
York Ave	3	SB	0	0	318	0	0	1128
59th St & 2nd Ave								
2019 (TMC-025)	4							
Queensboro Bridge Exit (SWB)	4							
59th St	4	EB	0	0	727	14	14	
	4	WB	0	0	0	0	0	
	4	NB	0	0	0	0	0	
2nd Ave	4	SB	885	4	811	0	0	2455
60th Street & 2nd Ave								
2019 (TMC-026)	5	WB(bridge)						
Queensboro Bridge Exit (NWB)	5	NW	828	621	0	0	0	
60th St	5	EB	0	0	0	0	0	
60th St	5	WB	0	1	10	0	0	
	5	NB	0	0	0	0	0	
2nd Ave	5	SB	10	0	871	27	0	919
60th St & 1st Ave								
2019 (TMC-027)	6							
60th Ave	6	EB	0	275	106	0	0	
	6	WB	0	0	0	0	0	
1st Ave	6	NB	0	0	859	34	0	
	6	SB	0	0	0	0	0	1274

60th St & Lexington Ave 2019 (TMC-028)	7							
	7	EB	0	0	0	0	0	
60th St	7	WB	0	101	375	0	0	
	7	NB	0	0	0	0	0	
Lexington Ave	7	SB	0	0	729	61	0	1266
60th St & Park Ave 2019 (TMC-029)	8							
	8	EB	0	0	0	0	0	
60th St	8	WB	0	0	357	79	0	
Park Ave	8	NB	0	86	751	0	0	
Park Ave	8	SB	0	0	0	0	0	1273
60th St & Park Ave 2019 (TMC-029)	888							
	888	EB	0	0	0	0	0	
60th St	888	WB	0	80	363	0	0	
Park Ave	888	NB	0	0	0	0	0	
Park Ave	888	SB	0	0	1166	92	0	1701
60th St & Madison Ave 2019 (TMC-030)	9							
	9	EB	0	0	0	0	0	
60th St	9	WB	0	0	346	109	0	
Madison Ave	9	NB	0	105	612	0	0	
	9	SB	0	0	0	0	0	1172
62nd St & Queensboror Bridge Exit 2019 (TMC-031)	10							
62nd St	10	EB	0	8	184	0	0	
	10	WB	0	0	0	0	0	
Queensboro Bridge Exit	10	NB	0	0	491	517	0	
	10	SB	0	0	0	0	0	1200
60th St & 5th Ave 2019 (TMC-032)	11							
	11	EB	0	0	0	0	0	
60th St	11	WB	0	150	301	0	0	
	11	NB	0	0	0	0	0	
5th Ave	11	SB	0	0	652	210	0	1313

63rd St & York Ave 2019 (TMC-033)	12							
	12	EB	0	0	0	0	0	
63rd St	12	WB	0	216	212	65	0	
York Ave	12	NB	0	0	414	431	0	
York Ave	12	SB	0	332	342	74	0	2086
53rd St & FDR Drive 2019 (TMC-034)	13							
	13	EB	0	0	0	0	0	
53rd St	13	SW	0	0	0	233	0	
	13	NB	0	0	0	0	0	
FDR Drive	13	SB	0	0	0	221	0	454
61st St & 5th Ave 2019 (TMC-035)	14							
	14	EB	0	0	0	0	0	
61st St	14	WB	0	205	0	0	0	
	14	NB	0	0	0	0	0	
5th Ave	14	SB	0	0	657	0	0	862
65th St & 5th Ave 2019 (TMC-036)	15							
65th St	15	EB	0	0	755	327	0	
	15	WB	0	0	0	0	0	
	15	NB	0	0	0	0	0	
5th Ave	15	SB	0	78	681	0	0	1841
66th St & 5th Ave 2019 (TMC-037)	16							
	16	EB	0	0	0	0	0	
66th St	16	WB	0	57	363	0	0	
	16	NB	0	0	0	0	0	
5th Ave	16	SB	0	0	702	298	0	1420
79th St & 5th Ave 2019 (TMC-038)	17							
79th St	17	EB	0	0	375	229	0	
79th St	17	WB	0	90	390	0	0	
	17	NB	0	0	0	0	0	
5th Ave	17	SB	0	67	601	87	0	1839
71st St & York Ave 2019 (TMC-039)	18							
	18	EB	0	0	0	0	0	
71st St	18	WB	0	157	124	104	0	
York Ave	18	NB	0	48	307	0	0	
York Ave	18	SB	0	0	328	52	0	1120

CBD Tolling
UE #1 - Traffic Flowmap
MD With Action





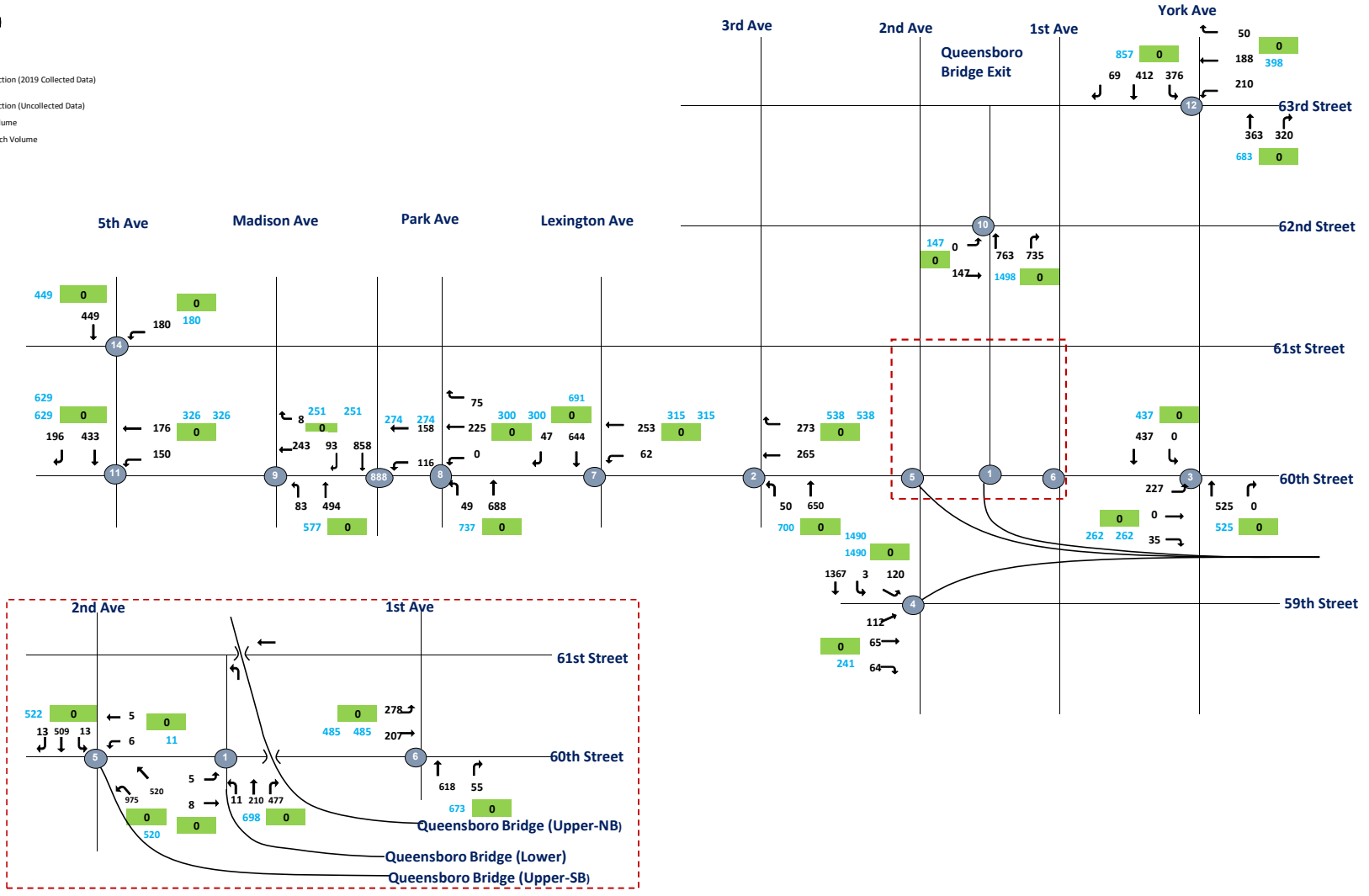

- Legend:**
- 1 - Intersection (2019 Collected Data)
 - 7 - Intersection (Uncollected Data)
 - 100 - ATR Volume
 - 100 - Approach Volume



CBD Tolling
UE #2 - Traffic Flowmap
MD With Action



- Legend:**
-  - Intersection (2019 Collected Data)
 -  - Intersection (Uncollected Data)
 -  - ATR Volume
 -  - Approach Volume

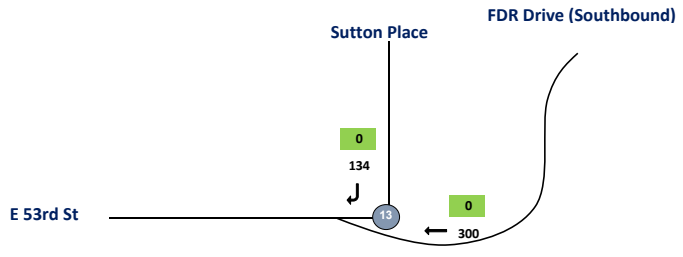

CBD Tolling
UE #3 - Traffic Flowmap
MD With Action



- Legend:**
- 1 - Intersection (2019 Collected Data)
 - 7 - Intersection (Uncollected Data)
 - 100 - ATR Volume
 - 100 - Approach Volume

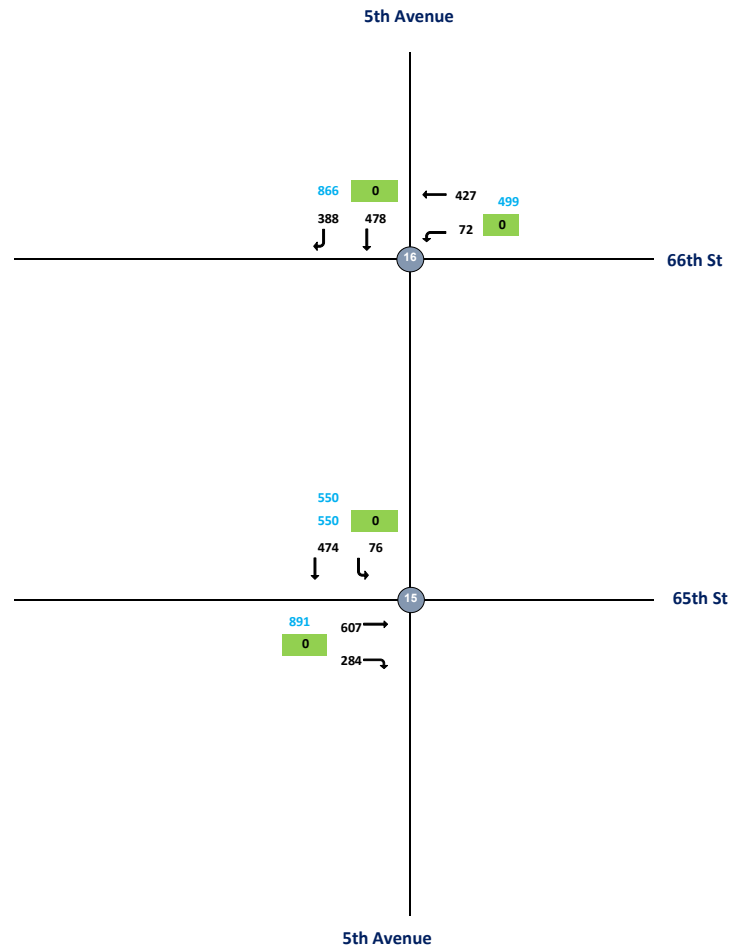

CBD Tolling
UE #3 - Traffic Flowmap
MD With Action



- Legend:**
- Intersection (2019 Collected Data)
 - Intersection (Uncollected Data)
 - 100 - ATR Volume
 - 100 - Approach Volume

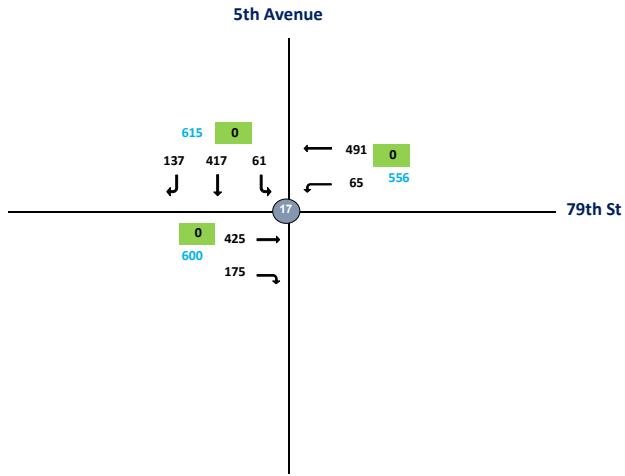

CBD Tolling
UE #4 - Traffic Flowmap
MD With Action



- Legend:**
- Intersection (2019 Collected Data)
 - Intersection (Uncollected Data)
 - 100 - ATR Volume
 - 100 - Approach Volume

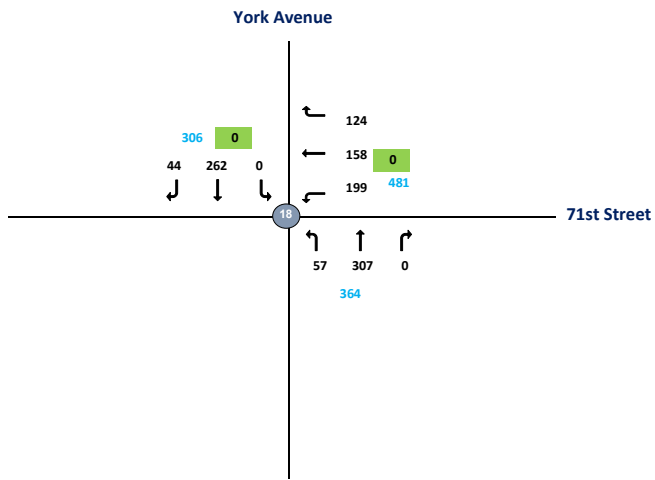

UE

1:00:00 MD

Intersection	Node	Approach	Total Vehicles					
			Inbound/Outbound					Total
			L2	L	T	R	R2	
60th Street & Queensboro Bridge Exit 2019 (TMC-022)	1							
60th Street	1	EB	0	5	8	0	0	
60th Street	1	WB	0	0	0	0	0	
Queensboro Bridge Exit	1	NB	0	11	210	477	0	
	1	SB	0	0	0	0	0	711
60th Street & 3rd Ave 2019 (TMC-023)	2							
60th Street	2	EB	0	0	0	0	0	
60th Street	2	WB	0	0	265	273	0	
3rd Ave	2	NB	0	50	650	0	0	
	2	SB	0	0	0	0	0	1238
60th St & York Ave 2019 (TMC-024)	3							
60th St	3	EB	0	227	0	35	0	
60th St	3	WB	0	0	0	0	0	
York Ave	3	NB	0	0	525	0	0	
York Ave	3	SB	0	0	437	0	0	1224
59th St & 2nd Ave 2019 (TMC-025)	4							
Queensboro Bridge Exit (SWB)	4							
59th St	4	EB	0	0	112	65	64	
	4	WB	0	0	0	0	0	
	4	NB	0	0	0	0	0	
2nd Ave	4	SB	120	3	1367	0	0	1731
60th Street & 2nd Ave 2019 (TMC-026)	5	WB(bridge)						
Queensboro Bridge Exit (NWB)	5	NW	975	520	0	0	0	
60th St	5	EB	0	0	0	0	0	
60th St	5	WB	0	6	5	0	0	
	5	NB	0	0	0	0	0	
2nd Ave	5	SB	13	0	509	13	0	546
60th St & 1st Ave 2019 (TMC-027)	6							
60th Ave	6	EB	0	278	207	0	0	
	6	WB	0	0	0	0	0	
1st Ave	6	NB	0	0	618	55	0	
	6	SB	0	0	0	0	0	1158

60th St & Lexington Ave 2019 (TMC-028)	7							
	7	EB	0	0	0	0	0	
60th St	7	WB	0	62	253	0	0	
	7	NB	0	0	0	0	0	
Lexington Ave	7	SB	0	0	644	47	0	1006
60th St & Park Ave 2019 (TMC-029)	8							
	8	EB	0	0	0	0	0	
60th St	8	WB	0	0	225	75	0	
Park Ave	8	NB	0	49	688	0	0	
Park Ave	8	SB	0	0	0	0	0	1037
60th St & Park Ave 2019 (TMC-029)	888							
	888	EB	0	0	0	0	0	
60th St	888	WB	0	116	158	0	0	
Park Ave	888	NB	0	0	0	0	0	
Park Ave	888	SB	0	0	858	93	0	1225
60th St & Madison Ave 2019 (TMC-030)	9							
	9	EB	0	0	0	0	0	
60th St	9	WB	0	0	243	8	0	
Madison Ave	9	NB	0	83	494	0	0	
	9	SB	0	0	0	0	0	828
62nd St & Queensboror Bridge Exit 2019 (TMC-031)	10							
62nd St	10	EB	0	0	147	0	0	
	10	WB	0	0	0	0	0	
Queensboro Bridge Exit	10	NB	0	0	763	735	0	
	10	SB	0	0	0	0	0	1645
60th St & 5th Ave 2019 (TMC-032)	11							
	11	EB	0	0	0	0	0	
60th St	11	WB	0	150	176	0	0	
	11	NB	0	0	0	0	0	
5th Ave	11	SB	0	0	433	196	0	955

63rd St & York Ave 2019 (TMC-033)	12							
	12	EB	0	0	0	0	0	
63rd St	12	WB	0	210	188	50	0	
York Ave	12	NB	0	0	363	320	0	
York Ave	12	SB	0	376	412	69	0	1988
53rd St & FDR Drive 2019 (TMC-034)	13							
	13	EB	0	0	0	0	0	
53rd St	13	SW	0	0	0	300	0	
	13	NB	0	0	0	0	0	
FDR Drive	13	SB	0	0	0	134	0	434
61st St & 5th Ave 2019 (TMC-035)	14							
	14	EB	0	0	0	0	0	
61st St	14	WB	0	180	0	0	0	
	14	NB	0	0	0	0	0	
5th Ave	14	SB	0	0	449	0	0	629
65th St & 5th Ave 2019 (TMC-036)	15							
65th St	15	EB	0	0	607	284	0	
	15	WB	0	0	0	0	0	
	15	NB	0	0	0	0	0	
5th Ave	15	SB	0	76	474	0	0	1441
66th St & 5th Ave 2019 (TMC-037)	16							
	16	EB	0	0	0	0	0	
66th St	16	WB	0	72	427	0	0	
	16	NB	0	0	0	0	0	
5th Ave	16	SB	0	0	478	388	0	1365
79th St & 5th Ave 2019 (TMC-038)	17							
79th St	17	EB	0	0	425	175	0	
79th St	17	WB	0	65	491	0	0	
	17	NB	0	0	0	0	0	
5th Ave	17	SB	0	61	417	137	0	1771
71st St & York Ave 2019 (TMC-039)	18							
	18	EB	0	0	0	0	0	
71st St	18	WB	0	199	158	124	0	
York Ave	18	NB	0	57	307	0	0	
York Ave	18	SB	0	0	262	44	0	1151

CBD Tolling
UE #1 - Traffic Flowmap
PM With Action



- Legend:**
- 1 - Intersection (2019 Collected Data)
 - 7 - Intersection (Uncollected Data)
 - 100 - ATR Volume
 - 100 - Approach Volume

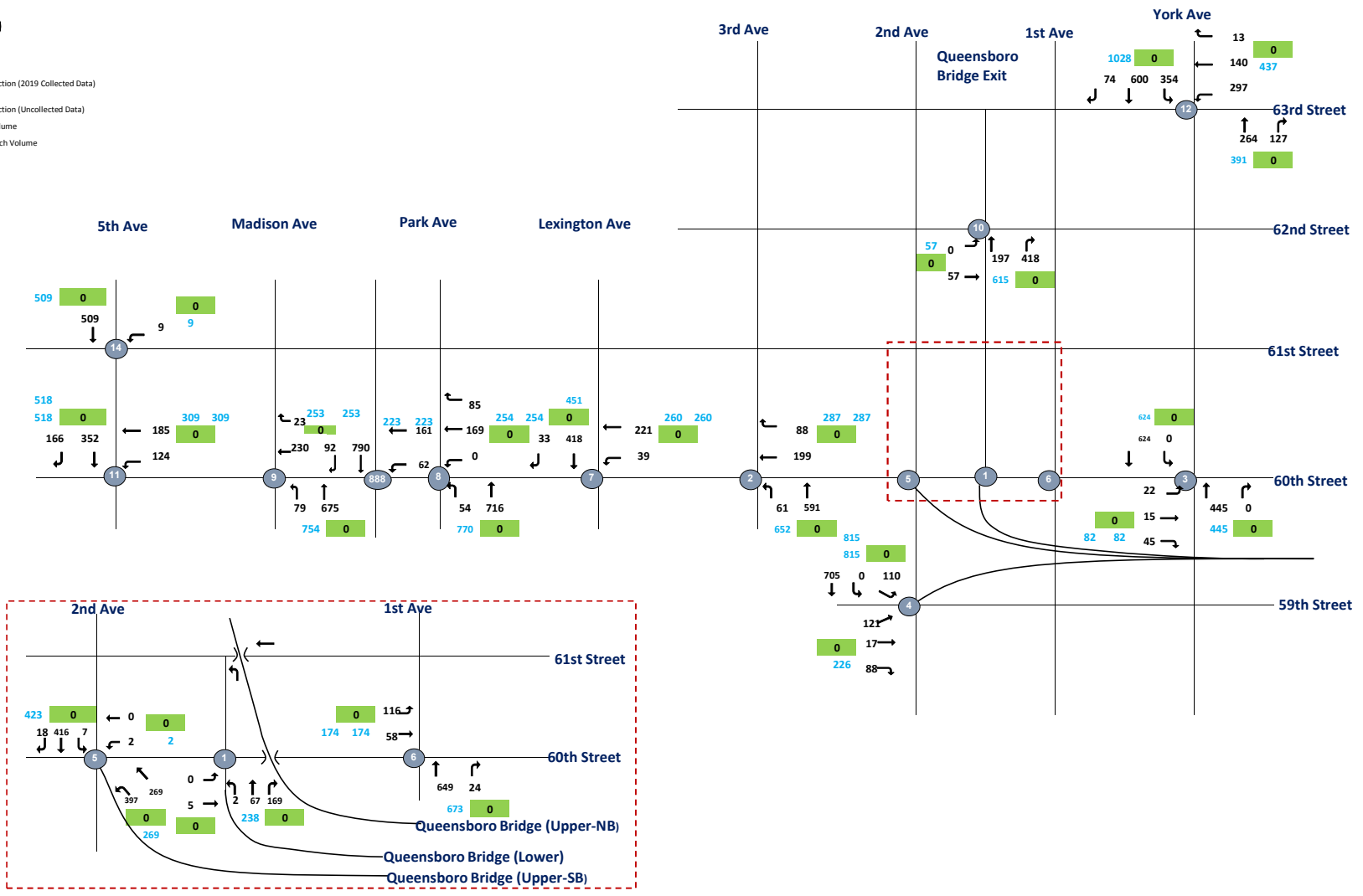

CBD Tolling
UE #2 - Traffic Flowmap
PM With Action



- Legend:**
- Intersection (2019 Collected Data)
 - Intersection (Uncollected Data)
 - 100 - ATR Volume
 - 100 - Approach Volume

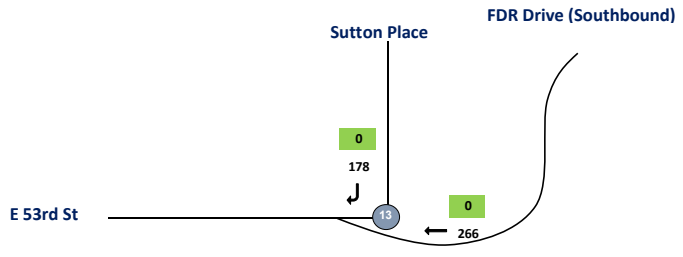

CBD Tolling
UE #3 - Traffic Flowmap
PM With Action



- Legend:**
- 1 - Intersection (2019 Collected Data)
 - 7 - Intersection (Uncollected Data)
 - 100 - ATR Volume
 - 100 - Approach Volume

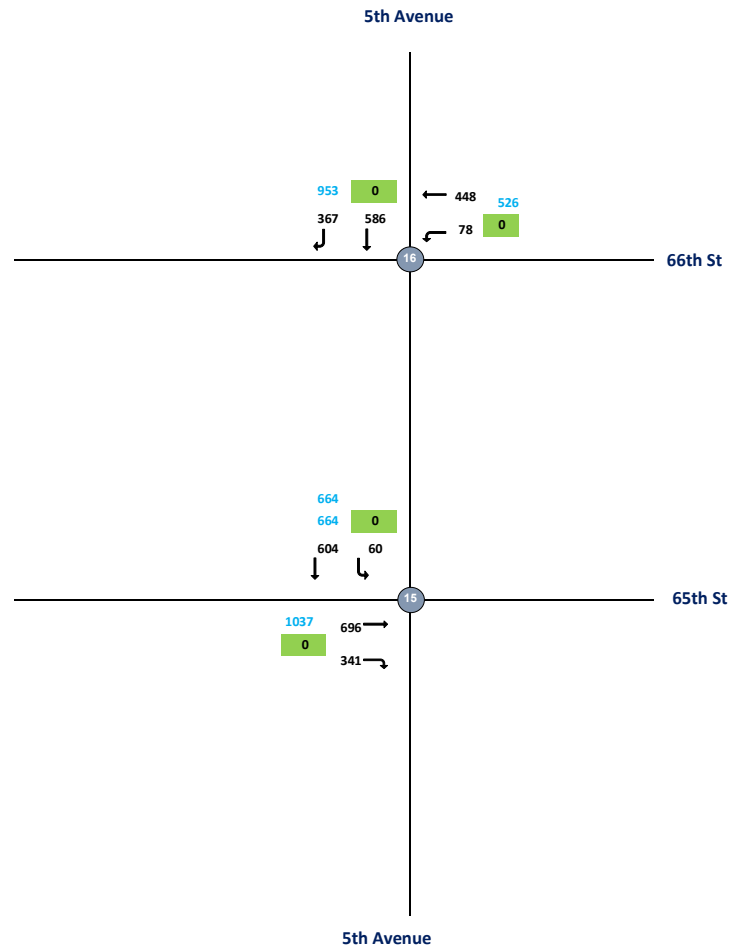

CBD Tolling
UE #3 - Traffic Flowmap
PM With Action



- Legend:**
- Intersection (2019 Collected Data)
 - Intersection (Uncollected Data)
 - 100 - ATR Volume
 - 100 - Approach Volume

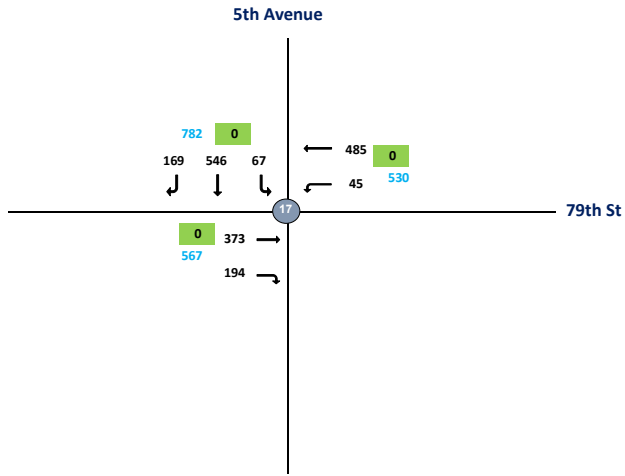

CBD Tolling
UE #4 - Traffic Flowmap
PM With Action



- Legend:**
- Intersection (2019 Collected Data)
 - Intersection (Uncollected Data)
 - 100 - ATR Volume
 - 100 - Approach Volume

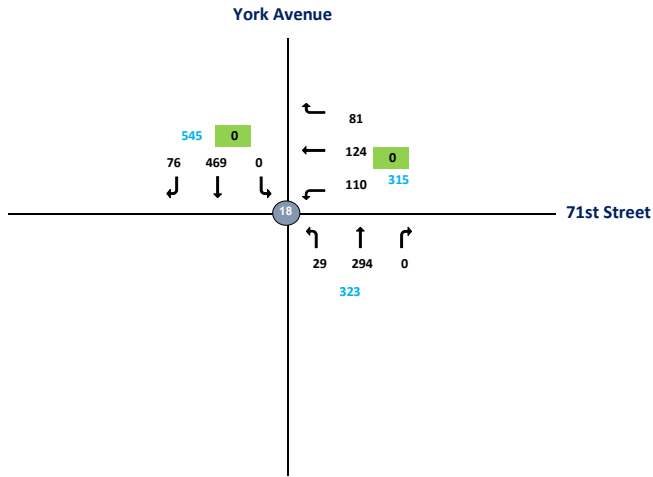

UE

5:00:00 PM

Intersection	Node	Approach	Total Vehicles						
			Inbound/Outbound					Total	
			L2	L	T	R	R2		
60th Street & Queensboro Bridge Exit 2019 (TMC-022)									
60th Street	1	EB	0	0	5	0	0	243	
60th Street	1	WB	0	0	0	0	0		
Queensboro Bridge Exit	1	NB	0	2	67	169	0		
	1	SB	0	0	0	0	0		
60th Street & 3rd Ave 2019 (TMC-023)									
	2	EB	0	0	0	0	0	939	
60th Street	2	WB	0	0	199	88	0		
3rd Ave	2	NB	0	61	591	0	0		
	2	SB	0	0	0	0	0		
60th St & York Ave 2019 (TMC-024)									
60th St	3	EB	0	22	15	45	0	1151	
60th St	3	WB	0	0	0	0	0		
York Ave	3	NB	0	0	445	0	0		
York Ave	3	SB	0	0	624	0	0		
59th St & 2nd Ave 2019 (TMC-025)									
Queensboro Bridge Exit (SWB)	4								1041
59th St	4	EB	0	0	121	17	88		
	4	WB	0	0	0	0	0		
	4	NB	0	0	0	0	0		
2nd Ave	4	SB	110	0	705	0	0		
60th Street & 2nd Ave 2019 (TMC-026)									
Queensboro Bridge Exit (NWB)	5	WB(bridge)	397	269	0	0	0	443	
60th St	5	EB	0	0	0	0	0		
60th St	5	WB	0	2	0	0	0		
	5	NB	0	0	0	0	0		
2nd Ave	5	SB	7	0	416	18	0		
60th St & 1st Ave 2019 (TMC-027)									
60th Ave	6	EB	0	116	58	0	0	847	
	6	WB	0	0	0	0	0		
1st Ave	6	NB	0	0	649	24	0		
	6	SB	0	0	0	0	0		

60th St & Lexington Ave 2019 (TMC-028)	7							
	7	EB	0	0	0	0	0	
60th St	7	WB	0	39	221	0	0	
	7	NB	0	0	0	0	0	
Lexington Ave	7	SB	0	0	418	33	0	711
60th St & Park Ave 2019 (TMC-029)	8							
	8	EB	0	0	0	0	0	
60th St	8	WB	0	0	169	85	0	
Park Ave	8	NB	0	54	716	0	0	
Park Ave	8	SB	0	0	0	0	0	1024
60th St & Park Ave 2019 (TMC-029)	888							
	888	EB	0	0	0	0	0	
60th St	888	WB	0	62	161	0	0	
Park Ave	888	NB	0	0	0	0	0	
Park Ave	888	SB	0	0	790	92	0	1105
60th St & Madison Ave 2019 (TMC-030)	9							
	9	EB	0	0	0	0	0	
60th St	9	WB	0	0	230	23	0	
Madison Ave	9	NB	0	79	675	0	0	
	9	SB	0	0	0	0	0	1007
62nd St & Queensboror Bridge Exit 2019 (TMC-031)	10							
62nd St	10	EB	0	0	57	0	0	
	10	WB	0	0	0	0	0	
Queensboro Bridge Exit	10	NB	0	0	197	418	0	
	10	SB	0	0	0	0	0	672
60th St & 5th Ave 2019 (TMC-032)	11							
	11	EB	0	0	0	0	0	
60th St	11	WB	0	124	185	0	0	
	11	NB	0	0	0	0	0	
5th Ave	11	SB	0	0	352	166	0	827

63rd St & York Ave 2019 (TMC-033)	12							
	12	EB	0	0	0	0	0	
63rd St	12	WB	0	297	140	13	0	
York Ave	12	NB	0	0	264	127	0	
York Ave	12	SB	0	354	600	74	0	1869
53rd St & FDR Drive 2019 (TMC-034)	13							
	13	EB	0	0	0	0	0	
53rd St	13	SW	0	0	0	266	0	
	13	NB	0	0	0	0	0	
FDR Drive	13	SB	0	0	0	178	0	444
61st St & 5th Ave 2019 (TMC-035)	14							
	14	EB	0	0	0	0	0	
61st St	14	WB	0	9	0	0	0	
	14	NB	0	0	0	0	0	
5th Ave	14	SB	0	0	509	0	0	518
65th St & 5th Ave 2019 (TMC-036)	15							
65th St	15	EB	0	0	696	341	0	
	15	WB	0	0	0	0	0	
	15	NB	0	0	0	0	0	
5th Ave	15	SB	0	60	604	0	0	1701
66th St & 5th Ave 2019 (TMC-037)	16							
	16	EB	0	0	0	0	0	
66th St	16	WB	0	78	448	0	0	
	16	NB	0	0	0	0	0	
5th Ave	16	SB	0	0	586	367	0	1479
79th St & 5th Ave 2019 (TMC-038)	17							
79th St	17	EB	0	0	373	194	0	
79th St	17	WB	0	45	485	0	0	
	17	NB	0	0	0	0	0	
5th Ave	17	SB	0	67	546	169	0	1879
71st St & York Ave 2019 (TMC-039)	18							
	18	EB	0	0	0	0	0	
71st St	18	WB	0	110	124	81	0	
York Ave	18	NB	0	29	294	0	0	
York Ave	18	SB	0	0	469	76	0	1183

CBD Tolling
UE #1 - Traffic Flowmap
LN With Action



- Legend:**
- 1 - Intersection (2019 Collected Data)
 - 7 - Intersection (Uncollected Data)
 - 100 - ATR Volume
 - 100 - Approach Volume

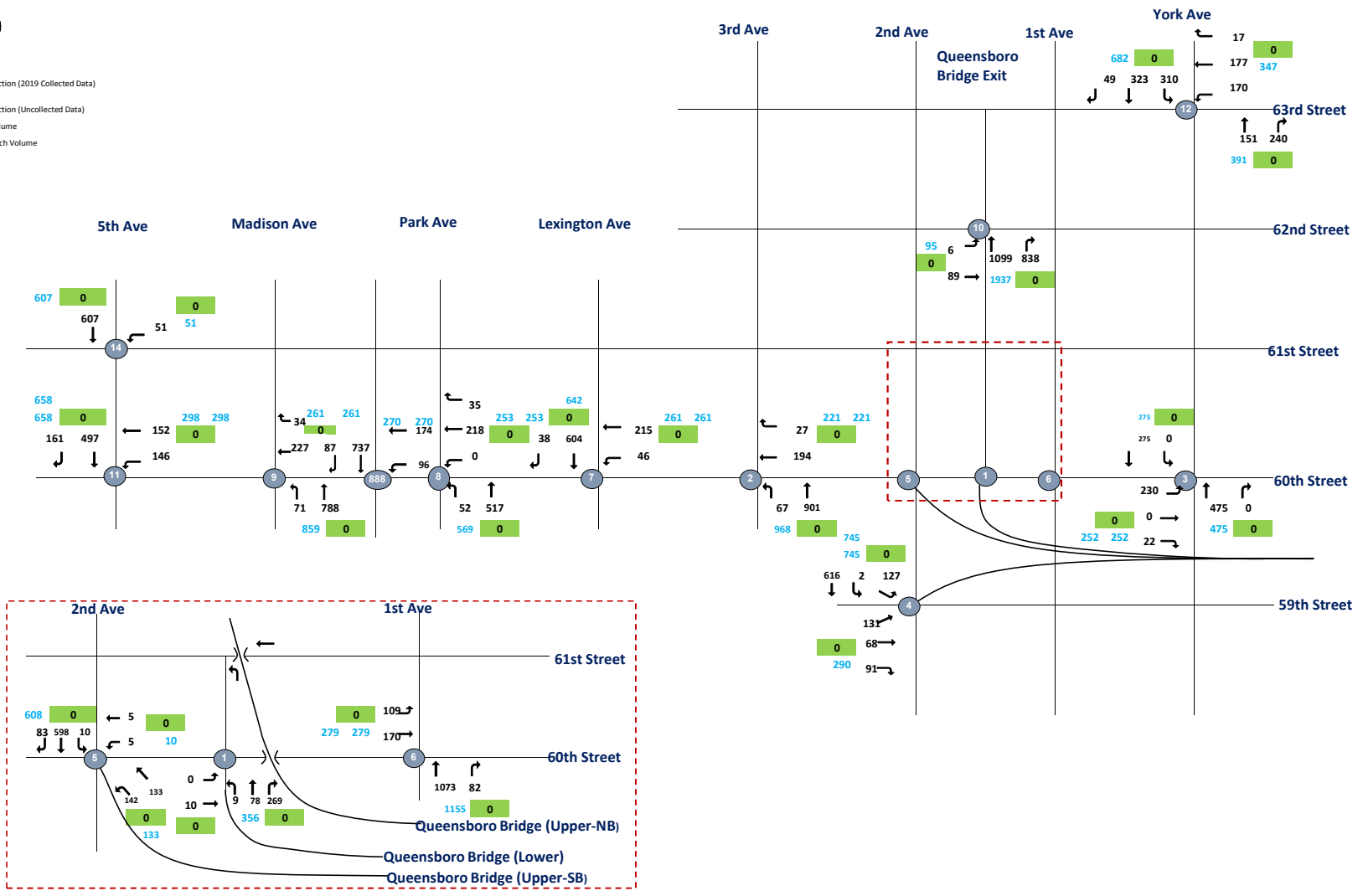

CBD Tolling
UE #2 - Traffic Flowmap
LN With Action



- Legend:**
- Intersection (2019 Collected Data)
 - Intersection (Uncollected Data)
 - 100 - ATR Volume
 - 100 - Approach Volume

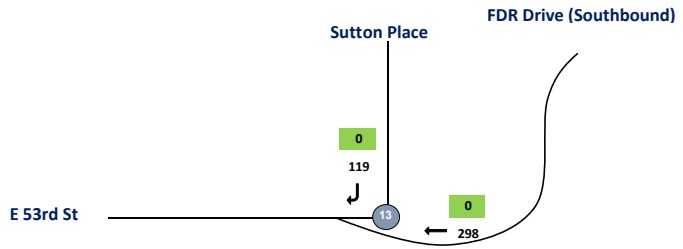

CBD Tolling
UE #3 - Traffic Flowmap
LN With Action



- Legend:**
- 1 - Intersection (2019 Collected Data)
 - 7 - Intersection (Uncollected Data)
 - 100 - ATR Volume
 - 100 - Approach Volume

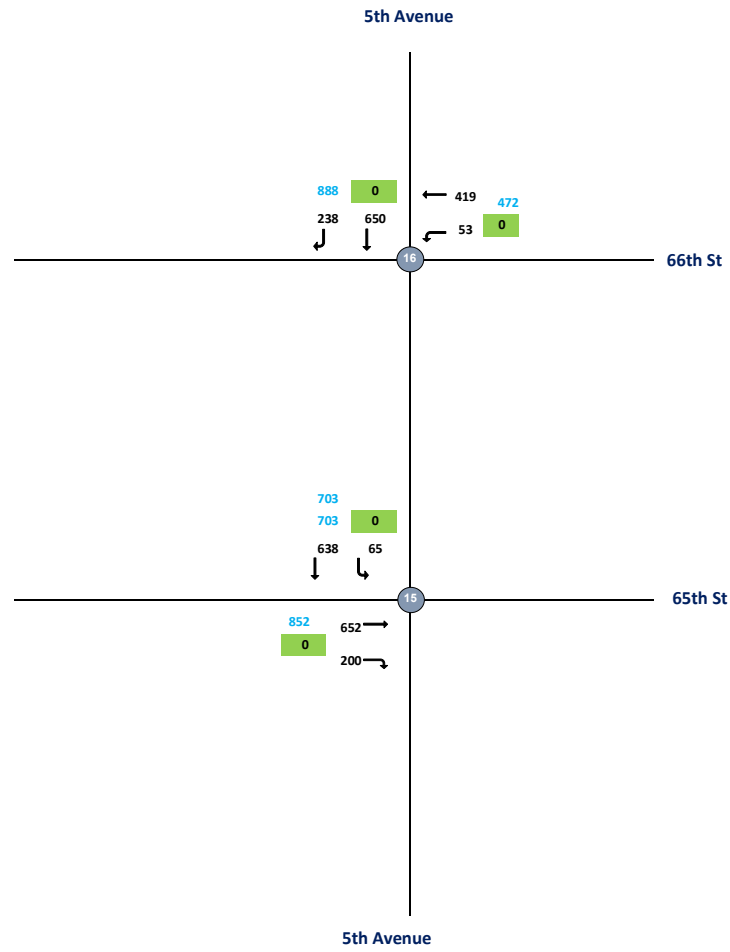

CBD Tolling
UE #3 - Traffic Flowmap
LN With Action



- Legend:**
- Intersection (2019 Collected Data)
 - Intersection (Uncollected Data)
 - 100 - ATR Volume
 - 100 - Approach Volume

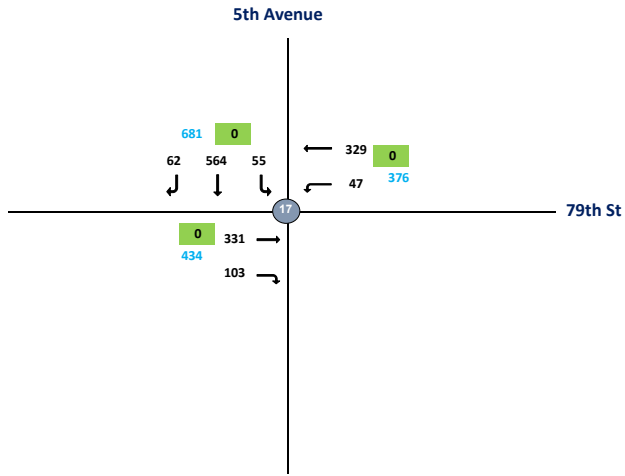

CBD Tolling
UE #4 - Traffic Flowmap
LN With Action



- Legend:**
- Intersection (2019 Collected Data)
 - Intersection (Uncollected Data)
 - 100 - ATR Volume
 - 100 - Approach Volume

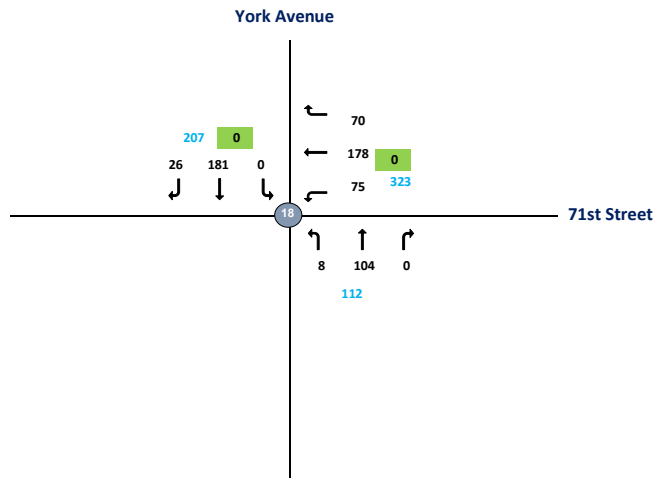

UE

9:00:00 PM

Intersection	Node	Approach	Total Vehicles						
			Inbound/Outbound						
			LN Peak Hour						
			L2	L	T	R	R2	Total	
60th Street & Queensboro Bridge Exit 2019 (TMC-022)	1								
60th Street	1	EB	0	0	10	0	0		
60th Street	1	WB	0	0	0	0	0		
Queensboro Bridge Exit	1	NB	0	9	78	269	0		
	1	SB	0	0	0	0	0		366
60th Street & 3rd Ave 2019 (TMC-023)	2								
60th Street	2	EB	0	0	0	0	0		
60th Street	2	WB	0	0	194	27	0		
3rd Ave	2	NB	0	67	901	0	0		
	2	SB	0	0	0	0	0		1189
60th St & York Ave 2019 (TMC-024)	3								
60th St	3	EB	0	230	0	22	0		
60th St	3	WB	0	0	0	0	0		
York Ave	3	NB	0	0	475	0	0		
York Ave	3	SB	0	0	275	0	0		1002
59th St & 2nd Ave 2019 (TMC-025)	4								
Queensboro Bridge Exit (SWB)	4								
59th St	4	EB	0	0	131	68	91		
	4	WB	0	0	0	0	0		
	4	NB	0	0	0	0	0		
2nd Ave	4	SB	127	2	616	0	0		1035
60th Street & 2nd Ave 2019 (TMC-026)	5	WB(bridge)							
Queensboro Bridge Exit (NWB)	5	NW	142	133	0	0	0		
60th St	5	EB	0	0	0	0	0		
60th St	5	WB	0	5	5	0	0		
	5	NB	0	0	0	0	0		
2nd Ave	5	SB	10	0	598	83	0		701
60th St & 1st Ave 2019 (TMC-027)	6								
60th Ave	6	EB	0	109	170	0	0		
	6	WB	0	0	0	0	0		
1st Ave	6	NB	0	0	1073	82	0		
	6	SB	0	0	0	0	0		1434

60th St & Lexington Ave 2019 (TMC-028)	7							
	7	EB	0	0	0	0	0	
60th St	7	WB	0	46	215	0	0	
	7	NB	0	0	0	0	0	
Lexington Ave	7	SB	0	0	604	38	0	903
60th St & Park Ave 2019 (TMC-029)	8							
	8	EB	0	0	0	0	0	
60th St	8	WB	0	0	218	35	0	
Park Ave	8	NB	0	52	517	0	0	
Park Ave	8	SB	0	0	0	0	0	822
60th St & Park Ave 2019 (TMC-029)	888							
	888	EB	0	0	0	0	0	
60th St	888	WB	0	96	174	0	0	
Park Ave	888	NB	0	0	0	0	0	
Park Ave	888	SB	0	0	737	87	0	1094
60th St & Madison Ave 2019 (TMC-030)	9							
	9	EB	0	0	0	0	0	
60th St	9	WB	0	0	227	34	0	
Madison Ave	9	NB	0	71	788	0	0	
	9	SB	0	0	0	0	0	1120
62nd St & Queensboror Bridge Exit 2019 (TMC-031)	10							
62nd St	10	EB	0	6	89	0	0	
	10	WB	0	0	0	0	0	
Queensboro Bridge Exit	10	NB	0	0	1099	838	0	
	10	SB	0	0	0	0	0	2032
60th St & 5th Ave 2019 (TMC-032)	11							
	11	EB	0	0	0	0	0	
60th St	11	WB	0	146	152	0	0	
	11	NB	0	0	0	0	0	
5th Ave	11	SB	0	0	497	161	0	956

63rd St & York Ave 2019 (TMC-033)	12							
	12	EB	0	0	0	0	0	
63rd St	12	WB	0	170	177	17	0	
York Ave	12	NB	0	0	151	240	0	
York Ave	12	SB	0	310	323	49	0	1437
53rd St & FDR Drive 2019 (TMC-034)	13							
	13	EB	0	0	0	0	0	
53rd St	13	SW	0	0	0	298	0	
	13	NB	0	0	0	0	0	
FDR Drive	13	SB	0	0	0	119	0	417
61st St & 5th Ave 2019 (TMC-035)	14							
	14	EB	0	0	0	0	0	
61st St	14	WB	0	51	0	0	0	
	14	NB	0	0	0	0	0	
5th Ave	14	SB	0	0	607	0	0	658
65th St & 5th Ave 2019 (TMC-036)	15							
65th St	15	EB	0	0	652	200	0	
	15	WB	0	0	0	0	0	
	15	NB	0	0	0	0	0	
5th Ave	15	SB	0	65	638	0	0	1555
66th St & 5th Ave 2019 (TMC-037)	16							
	16	EB	0	0	0	0	0	
66th St	16	WB	0	53	419	0	0	
	16	NB	0	0	0	0	0	
5th Ave	16	SB	0	0	650	238	0	1360
79th St & 5th Ave 2019 (TMC-038)	17							
79th St	17	EB	0	0	331	103	0	
79th St	17	WB	0	47	329	0	0	
	17	NB	0	0	0	0	0	
5th Ave	17	SB	0	55	564	62	0	1491
71st St & York Ave 2019 (TMC-039)	18							
	18	EB	0	0	0	0	0	
71st St	18	WB	0	75	178	70	0	
York Ave	18	NB	0	8	104	0	0	
York Ave	18	SB	0	0	181	26	0	642

CBD Tolling
UW #1 - Traffic Flowmap
AM With Action



- Legend:**
- Intersection (2019 Collected Data)
 - Intersection (Uncollected Data)
 - ATR Volume
 - 100 - Approach Volume

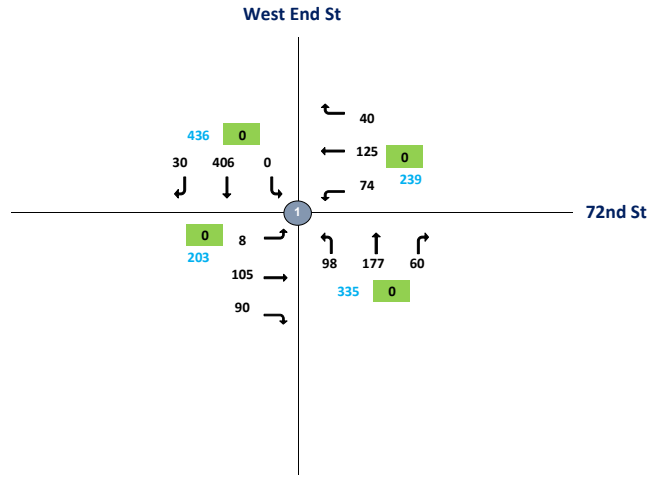

CBD Tolling
UW #2 - Traffic Flowmap
AM With Action



- Legend:**
- 1 - Intersection (2019 Collected Data)
 - 2 - Intersection (Uncollected Data)
 - 100 - ATR Volume
 - 100 - Approach Volume

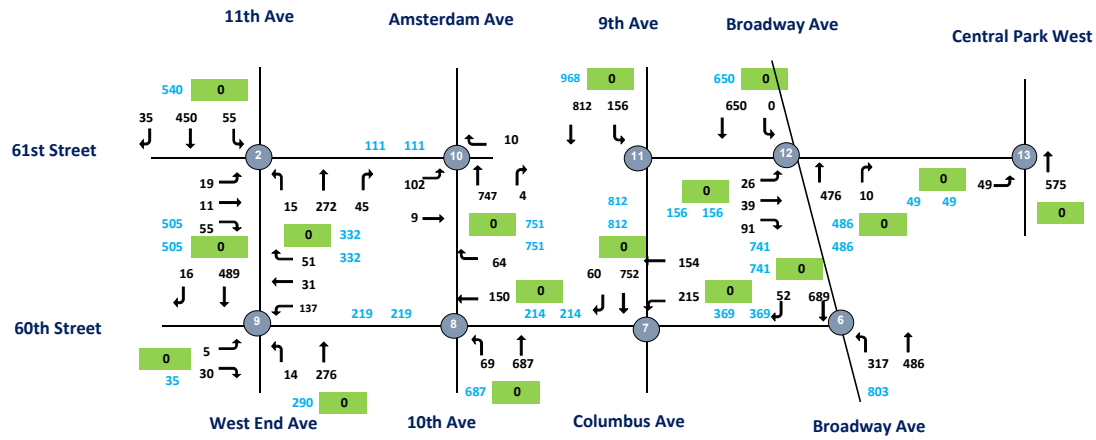

CBD Tolling
UW #3 - Traffic Flowmap
AM With Action



- Legend:**
- Intersection (2019 Collected Data)
 - Intersection (Uncollected Data)
 - ATR Volume
 - Approach Volume

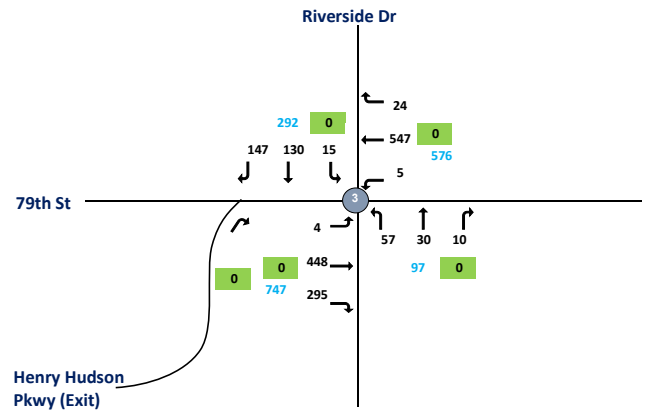

CBD Tolling
UW #4 - Traffic Flowmap
AM With Action



- Legend:**
- 1 - Intersection (2019 Collected Data)
 - 7 - Intersection (Uncollected Data)
 - 100 - ATR Volume
 - 100 - Approach Volume

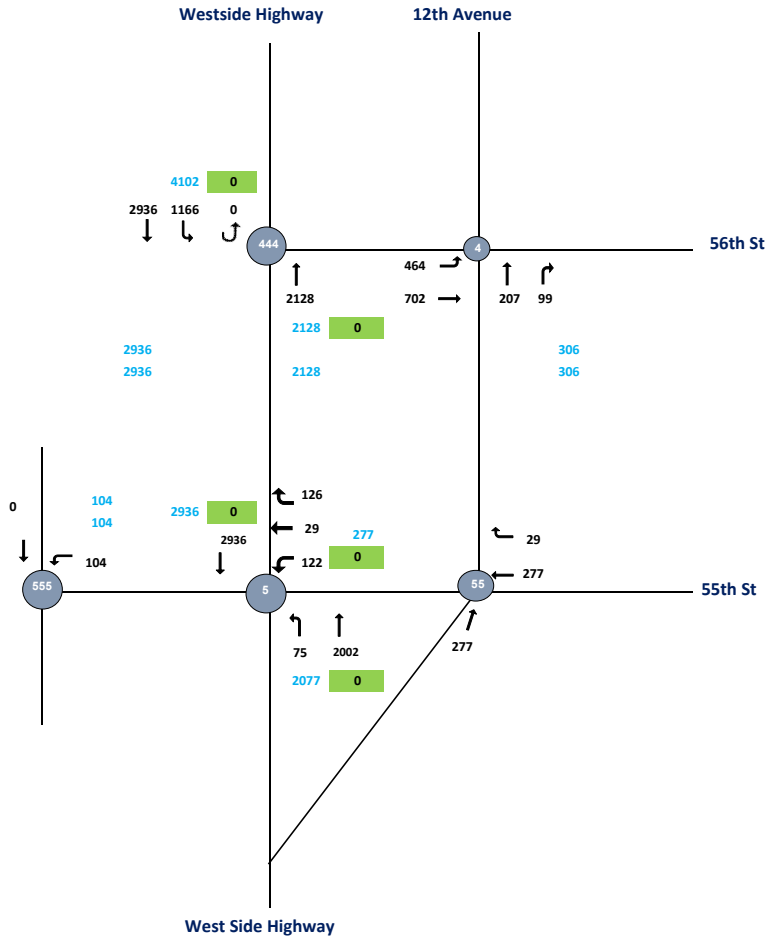

CBD Tolling
UW #5 - Traffic Flowmap
AM With Action



- Legend:**
- Intersection (2019 Collected Data)
 - Intersection (Uncollected Data)
 - ATR Volume
 - Approach Volume

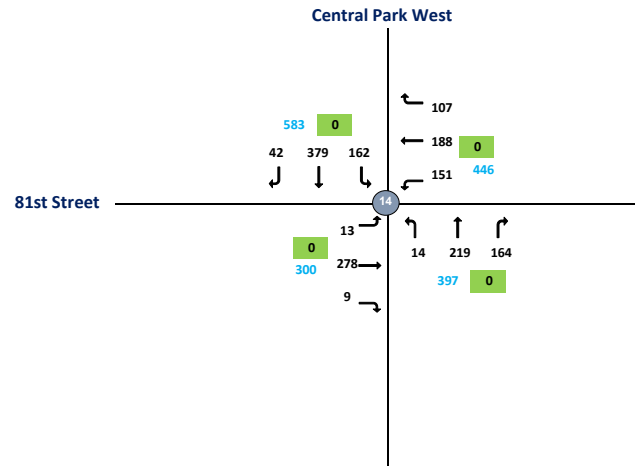

CBD Tolling
UW #6 - Traffic Flowmap
AM With Action



- Legend:**
- 1 - Intersection (2019 Collected Data)
 - 7 - Intersection (Uncollected Data)
 - 100 - ATR Volume
 - 100 - Approach Volume

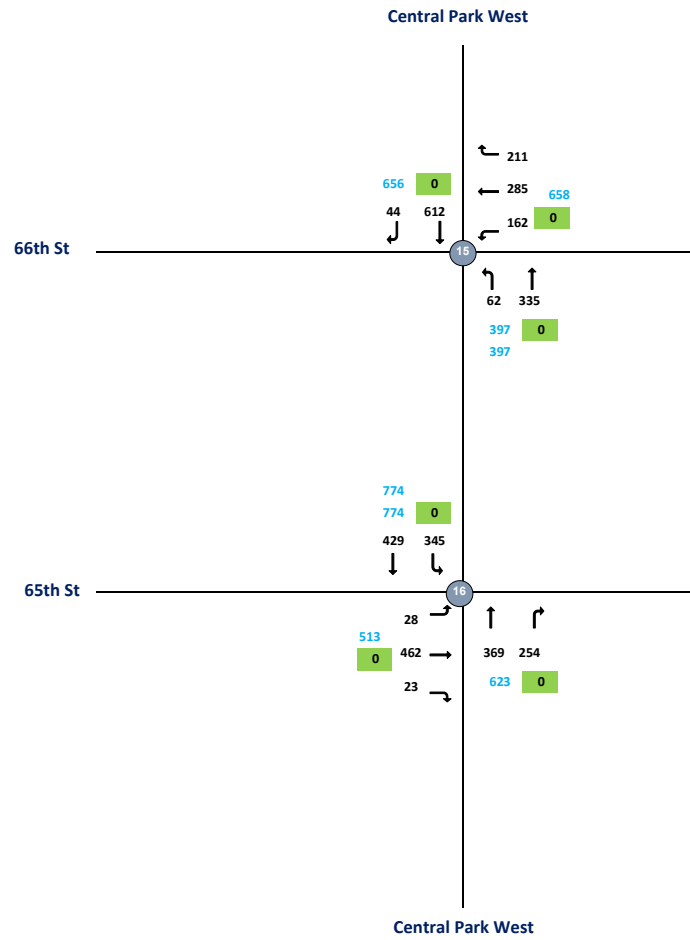

Intersection	Node	Approach	Total Vehicles					
			Inbound/Outbound					
			AM Peak Hour					
			L2	L	T	R	R2	Total
W 72nd St and West End St 2019 (TMC-042)	1							
W 72nd St	1	EB	0	8	105	90	0	
W 72nd St	1	WB	0	74	125	40	0	
West End St	1	NB	0	98	177	60	0	
West End St	1	SB	0	0	406	30	0	1213
W 61st St and West End St 2019 (TMC-043)	2							
W 61st St	2	EB	0	19	11	55	0	
W 61st St	2	WB	0	0	0	0	0	
West End St	2	NB	0	15	272	45	0	
West End St	2	SB	0	55	450	35	0	957
W 79th St and Riverside Dr 2019 (TMC-044)	3	NEB						
W 79th St	3	EB	0	4	448	295	0	
W 79th St	3	WB	0	5	547	24	0	
Riverside Dr	3	NB	0	57	30	10	0	
Riverside Dr	3	SB	0	15	130	147	0	1712
W 79th St and Riverside Dr 2019 (TMC-044)	333							
W 79th St	333	EB	0	0	0	0	0	
W 79th St	333	WB	0	0	0	0	0	
Riverside Dr	333	NB	0	0	0	0	0	
Riverside Dr	333	SB	0	0	0	0	0	0
W 56th St and West Side Hwy 2019 (TMC-045)	4							
-	4	EB	0	464	702	0	0	
W 56th St	4	WB	0	0	0	0	0	
West Side Hwy	4	NB	0	0	207	99	0	
West Side Hwy	4	SB	0	0	0	0	0	1472
W 56th St and West Side Hwy 2019 (TMC-045)	444							
-	444	EB	0	0	0	0	0	
W 56th St	444	WB	0	0	0	0	0	
West Side Hwy	444	NB	0	0	2128	0	0	
West Side Hwy	444	SB	0	1166	2936	0	0	6230
W 55th St and West Side Hwy 2019 (TMC-046)	5							
-	5	EB	0	0	0	0	0	
W 55th St	5	WB	0	122	29	126	0	
West Side Hwy	5	NB	0	75	2002	0	0	
West Side Hwy	5	SB	0	0	2936	0	0	5290

W 55th St and West Side Hwy									
2019 (TMC-046 B B)		55							
-		55	EB	0	0	0	0	0	
W 55th St		55	WB	0	0	277	29	0	
West Side Hwy		55	NB	0	0	277	0	0	
West Side Hwy		55	SB	0	0	0	0	0	583
W 55th St and West Side Hwy									
2019 (TMC-046)		555							
-		555	EB	0	0	0	0	0	
W 55th St		555	WB	0	104	0	0	0	
West Side Hwy		555	NB	0	0	0	0	0	
West Side Hwy		555	SB	0	0	0	0	0	104
W 60th St and Broadway									
2019 (TMC-047)		6							
-		6	EB	0	0	0	0	0	
W 60th St		6	WB	0	0	0	0	0	
Broadway		6	NB	0	317	486	0	0	
Broadway		6	SB	0	0	689	52	0	1544
W 60th St and Columbus Ave									
2019 (TMC-048)		7							
W 60th St		7	EB	0	0	0	0	0	
W 60th St		7	WB	0	215	154	0	0	
Columbus Ave		7	NB	0	0	0	0	0	
Columbus Ave		7	SB	0	0	752	60	0	1181
W 60th St and 10th Ave									
2019 (TMC-049)		8							
W 60th St		8	EB	0	0	0	0	0	
W 60th St		8	WB	0	0	150	64	0	
10th Ave		8	NB	0	69	687	0	0	
10th Ave		8	SB	0	0	0	0	0	970
W 60th St and 11th Ave									
2019 (TMC-050)		9							
W 60th St		9	EB	0	5	0	30	0	
W 60th St		9	WB	0	137	31	51	0	
11th Ave		9	NB	0	14	276	0	0	
11th Ave		9	SB	0	0	489	16	0	1049
W 61st St and 10th Ave									
2019 (TMC-051)		10							
W 61st St		10	EB	0	102	9	0	0	
W 61st St		10	WB	0	0	0	10	0	
10th Ave		10	NB	0	0	747	4	0	
10th Ave		10	SB	0	0	0	0	0	872

W 61st St and Columbus Ave									
2019 (TMC-052)	11								
-	11	EB	0	0	0	0	0		
W 61st St	11	WB	0	0	0	0	0		
Columbus Ave	11	NB	0	0	0	0	0		
Columbus Ave	11	SB	0	156	812	0	0		968
W 61st St and Broadway									
2019 (TMC-053)	12								
W 61st St	12	EB	0	26	39	91	0		
W 61st St	12	WB	0	0	0	0	0		
Broadway	12	NB	0	0	476	10	0		
Broadway	12	SB	0	0	650	0	0		1292
Central Park and W 61st St									
2019 (TMC-054)	13								
W 61st St	13	EB	0	49	0	0	0		
-	13	WB	0	0	0	0	0		
Central Park	13	NB	0	0	575	0	0		
Central Park	13	SB	0	0	0	0	0		624
Central Park and W 81st St									
2019 (TMC-055)	14								
W 81st St	14	EB	0	13	278	9	0		
W 79th St Transverse	14	WB	0	151	188	107	0		
Central Park	14	NB	0	14	219	164	0		
Central Park	14	SB	0	162	379	42	0		1726
Central Park West and W 66th St									
2019 (TMC-056)	15								
W 66th St	15	EB	0	0	0	0	0		
W 66th St	15	WB	0	162	285	211	0		
Central Park West	15	NB	0	62	335	0	0		
Central Park West	15	SB	0	0	612	44	0		1711
Central Park West and W 65th St									
2019 (TMC-057)	16								
W 65th St	16	EB	0	28	462	23	0		
W 65th St	16	WB	0	0	0	0	0		
Central Park West	16	NB	0	0	369	254	0		
Central Park West	16	SB	0	345	429	0	0		1910

CBD Tolling
UW #1 - Traffic Flowmap
MD With Action



- Legend:**
- 1 - Intersection (2019 Collected Data)
 - 7 - Intersection (Uncollected Data)
 - 100 - ATR Volume
 - 100 - Approach Volume

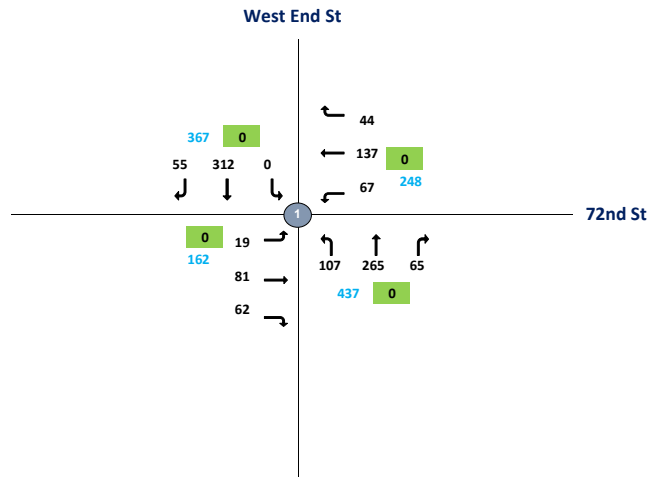

CBD Tolling
UW #2 - Traffic Flowmap
MD With Action



- Legend:**
- 1 - Intersection (2019 Collected Data)
 - 2 - Intersection (Uncollected Data)
 - 100 - ATR Volume
 - 100 - Approach Volume

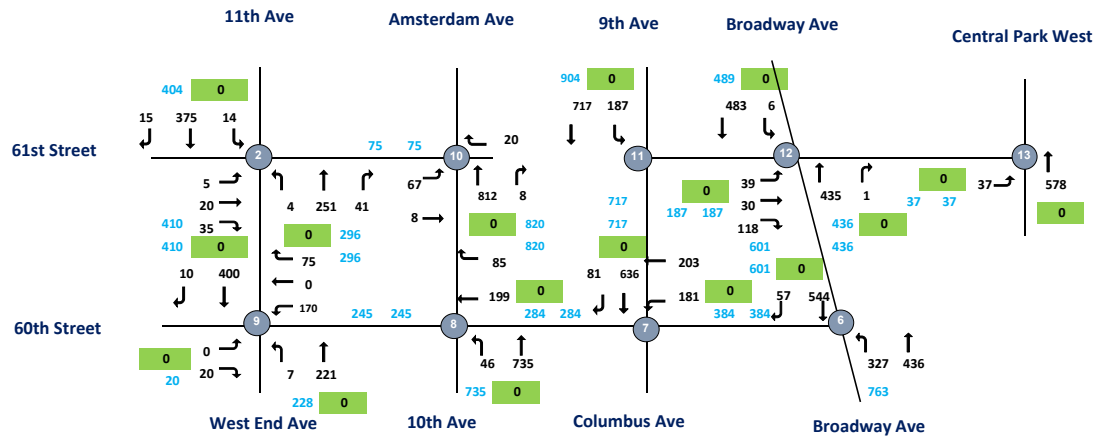

CBD Tolling
UW #3 - Traffic Flowmap
MD With Action



- Legend:**
- Intersection (2019 Collected Data)
 - Intersection (Uncollected Data)
 - ATR Volume
 - Approach Volume

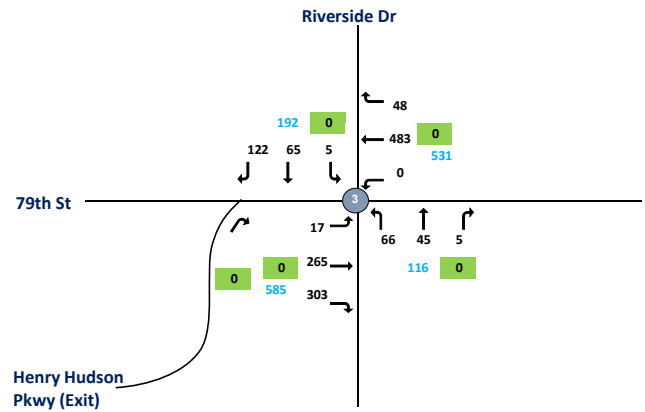

CBD Tolling
UW #4 - Traffic Flowmap
MD With Action



- Legend:**
- 1 - Intersection (2019 Collected Data)
 - 7 - Intersection (Uncollected Data)
 - 100 - ATR Volume
 - 100 - Approach Volume

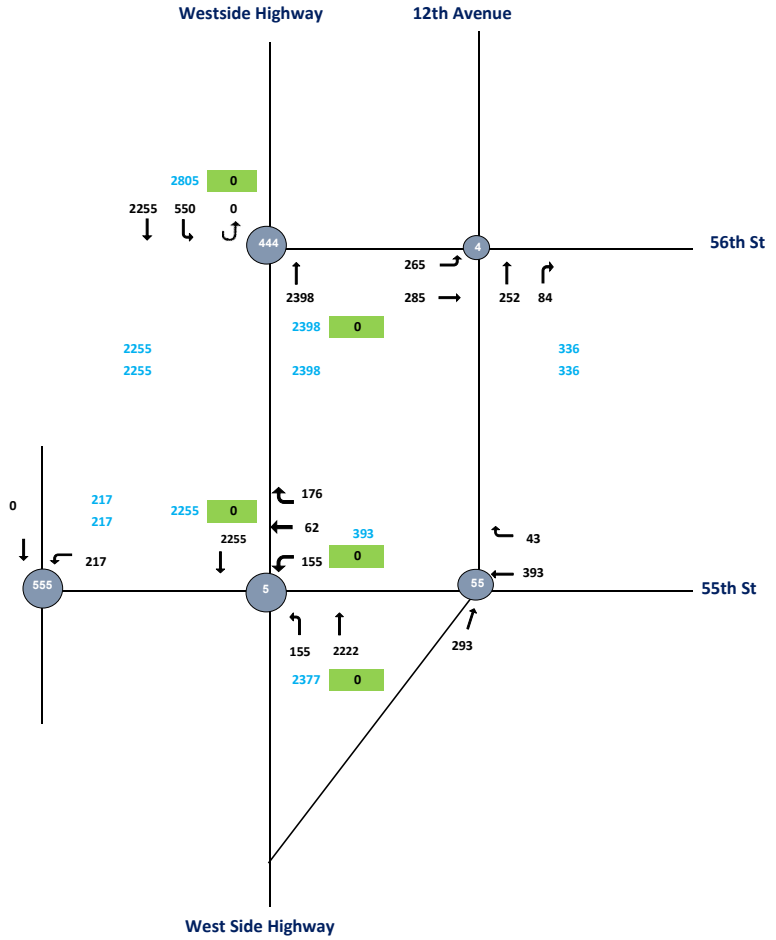

CBD Tolling
UW #5 - Traffic Flowmap
MD With Action



- Legend:**
- 1 - Intersection (2019 Collected Data)
 - 7 - Intersection (Uncollected Data)
 - 100 - ATR Volume
 - 100 - Approach Volume

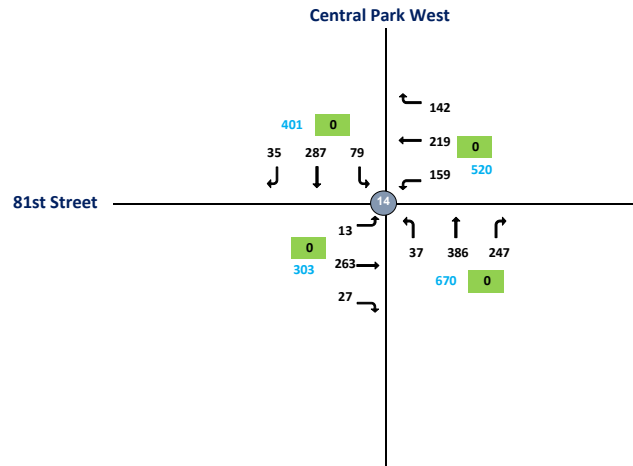

CBD Tolling
UW #6 - Traffic Flowmap
MD With Action



- Legend:**
- 1 - Intersection (2019 Collected Data)
 - 7 - Intersection (Uncollected Data)
 - 100 - ATR Volume
 - 100 - Approach Volume

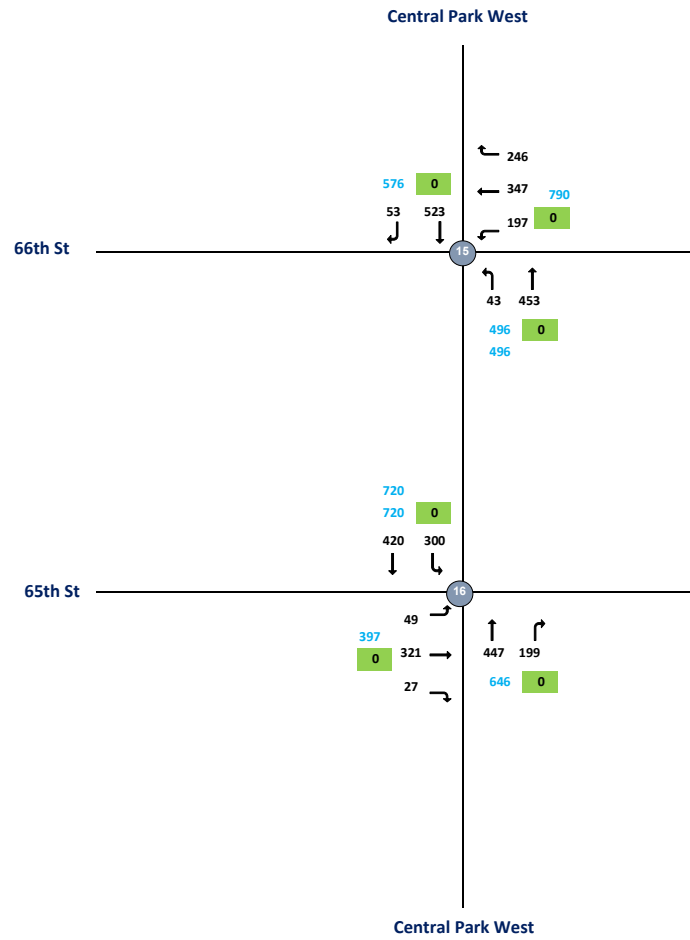

Intersection	Node	Approach	Total Vehicles					
			Inbound/Outbound					
			MD Peak Hour					
			L2	L	T	R	R2	Total
W 72nd St and West End St 2019 (TMC-042)	1							
W 72nd St	1	EB	0	19	81	62	0	
W 72nd St	1	WB	0	67	137	44	0	
West End St	1	NB	0	107	265	65	0	
West End St	1	SB	0	0	312	55	0	1214
W 61st St and West End St 2019 (TMC-043)	2							
W 61st St	2	EB	0	5	20	35	0	
W 61st St	2	WB	0	0	0	0	0	
West End St	2	NB	0	4	251	41	0	
West End St	2	SB	0	14	375	15	0	760
W 79th St and Riverside Dr 2019 (TMC-044)	3	NEB						
W 79th St	3	EB	0	17	265	303	0	
W 79th St	3	WB	0	0	483	48	0	
Riverside Dr	3	NB	0	66	45	5	0	
Riverside Dr	3	SB	0	5	65	122	0	1424
W 79th St and Riverside Dr 2019 (TMC-044)	333							
W 79th St	333	EB	0	0	0	0	0	
W 79th St	333	WB	0	0	0	0	0	
Riverside Dr	333	NB	0	0	0	0	0	
Riverside Dr	333	SB	0	0	0	0	0	0
W 56th St and West Side Hwy 2019 (TMC-045)	4							
-	4	EB	0	265	285	0	0	
W 56th St	4	WB	0	0	0	0	0	
West Side Hwy	4	NB	0	0	252	84	0	
West Side Hwy	4	SB	0	0	0	0	0	886
W 56th St and West Side Hwy 2019 (TMC-045)	444							
-	444	EB	0	0	0	0	0	
W 56th St	444	WB	0	0	0	0	0	
West Side Hwy	444	NB	0	0	2398	0	0	
West Side Hwy	444	SB	0	550	2255	0	0	5203
W 55th St and West Side Hwy 2019 (TMC-046)	5							
-	5	EB	0	0	0	0	0	
W 55th St	5	WB	0	155	62	176	0	
West Side Hwy	5	NB	0	155	2222	0	0	
West Side Hwy	5	SB	0	0	2255	0	0	5025

W 55th St and West Side Hwy									
2019 (TMC-046 B B)		55							
-	55	EB	0	0	0	0	0		
W 55th St	55	WB	0	0	393	43	0		
West Side Hwy	55	NB	0	0	293	0	0		
West Side Hwy	55	SB	0	0	0	0	0		729
W 55th St and West Side Hwy									
2019 (TMC-046)		555							
-	555	EB	0	0	0	0	0		
W 55th St	555	WB	0	217	0	0	0		
West Side Hwy	555	NB	0	0	0	0	0		
West Side Hwy	555	SB	0	0	0	0	0		217
W 60th St and Broadway									
2019 (TMC-047)		6							
-	6	EB	0	0	0	0	0		
W 60th St	6	WB	0	0	0	0	0		
Broadway	6	NB	0	327	436	0	0		
Broadway	6	SB	0	0	544	57	0		1364
W 60th St and Columbus Ave									
2019 (TMC-048)		7							
W 60th St	7	EB	0	0	0	0	0		
W 60th St	7	WB	0	181	203	0	0		
Columbus Ave	7	NB	0	0	0	0	0		
Columbus Ave	7	SB	0	0	636	81	0		1101
W 60th St and 10th Ave									
2019 (TMC-049)		8							
W 60th St	8	EB	0	0	0	0	0		
W 60th St	8	WB	0	0	199	85	0		
10th Ave	8	NB	0	46	735	0	0		
10th Ave	8	SB	0	0	0	0	0		1065
W 60th St and 11th Ave									
2019 (TMC-050)		9							
W 60th St	9	EB	0	0	0	20	0		
W 60th St	9	WB	0	170	0	75	0		
11th Ave	9	NB	0	7	221	0	0		
11th Ave	9	SB	0	0	400	10	0		903
W 61st St and 10th Ave									
2019 (TMC-051)		10							
W 61st St	10	EB	0	67	8	0	0		
W 61st St	10	WB	0	0	0	20	0		
10th Ave	10	NB	0	0	812	8	0		
10th Ave	10	SB	0	0	0	0	0		915

W 61st St and Columbus Ave									
2019 (TMC-052)	11								
-	11	EB	0	0	0	0	0		
W 61st St	11	WB	0	0	0	0	0		
Columbus Ave	11	NB	0	0	0	0	0		
Columbus Ave	11	SB	0	187	717	0	0		904
W 61st St and Broadway									
2019 (TMC-053)	12								
W 61st St	12	EB	0	39	30	118	0		
W 61st St	12	WB	0	0	0	0	0		
Broadway	12	NB	0	0	435	1	0		
Broadway	12	SB	0	6	483	0	0		1112
Central Park and W 61st St									
2019 (TMC-054)	13								
W 61st St	13	EB	0	37	0	0	0		
-	13	WB	0	0	0	0	0		
Central Park	13	NB	0	0	578	0	0		
Central Park	13	SB	0	0	0	0	0		615
Central Park and W 81st St									
2019 (TMC-055)	14								
W 81st St	14	EB	0	13	263	27	0		
W 79th St Transverse	14	WB	0	159	219	142	0		
Central Park	14	NB	0	37	386	247	0		
Central Park	14	SB	0	79	287	35	0		1894
Central Park West and W 66th St									
2019 (TMC-056)	15								
W 66th St	15	EB	0	0	0	0	0		
W 66th St	15	WB	0	197	347	246	0		
Central Park West	15	NB	0	43	453	0	0		
Central Park West	15	SB	0	0	523	53	0		1862
Central Park West and W 65th St									
2019 (TMC-057)	16								
W 65th St	16	EB	0	49	321	27	0		
W 65th St	16	WB	0	0	0	0	0		
Central Park West	16	NB	0	0	447	199	0		
Central Park West	16	SB	0	300	420	0	0		1763

CBD Tolling
UW #1 - Traffic Flowmap
PM With Action



- Legend:**
- 1 - Intersection (2019 Collected Data)
 - 7 - Intersection (Uncollected Data)
 - 100 - ATR Volume
 - 100 - Approach Volume

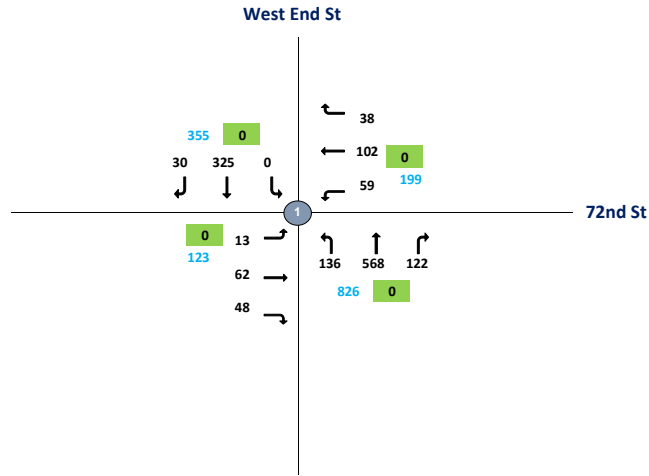

CBD Tolling
UW #2 - Traffic Flowmap
PM With Action



- Legend:**
- 1 - Intersection (2019 Collected Data)
 - 2 - Intersection (Uncollected Data)
 - 3 - Intersection (Uncollected Data)
 - 100 - ATR Volume
 - 100 - Approach Volume

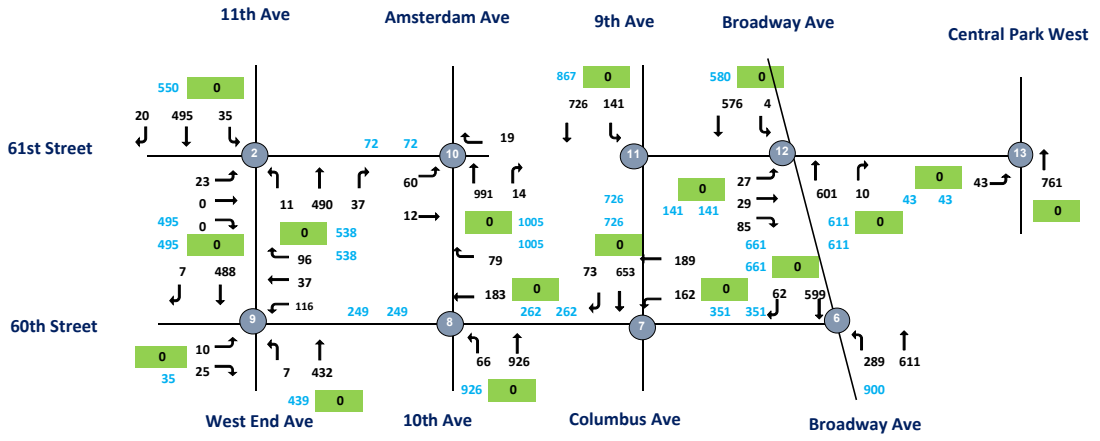

CBD Tolling
UW #3 - Traffic Flowmap
PM With Action



- Legend:**
- Intersection (2019 Collected Data)
 - Intersection (Uncollected Data)
 - ATR Volume
 - Approach Volume

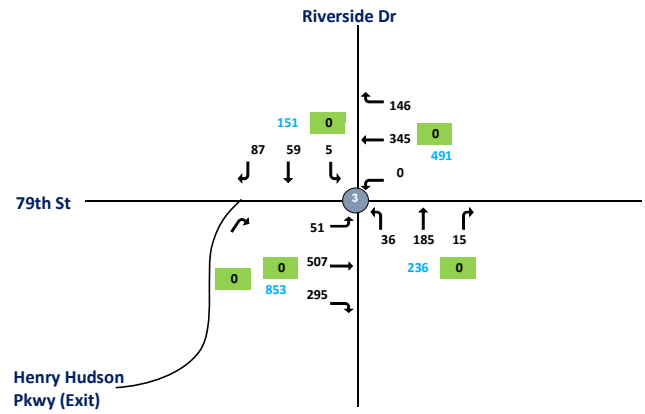

CBD Tolling
UW #4 - Traffic Flowmap
PM With Action



- Legend:**
- 1 - Intersection (2019 Collected Data)
 - 7 - Intersection (Uncollected Data)
 - 100 - ATR Volume
 - 100 - Approach Volume

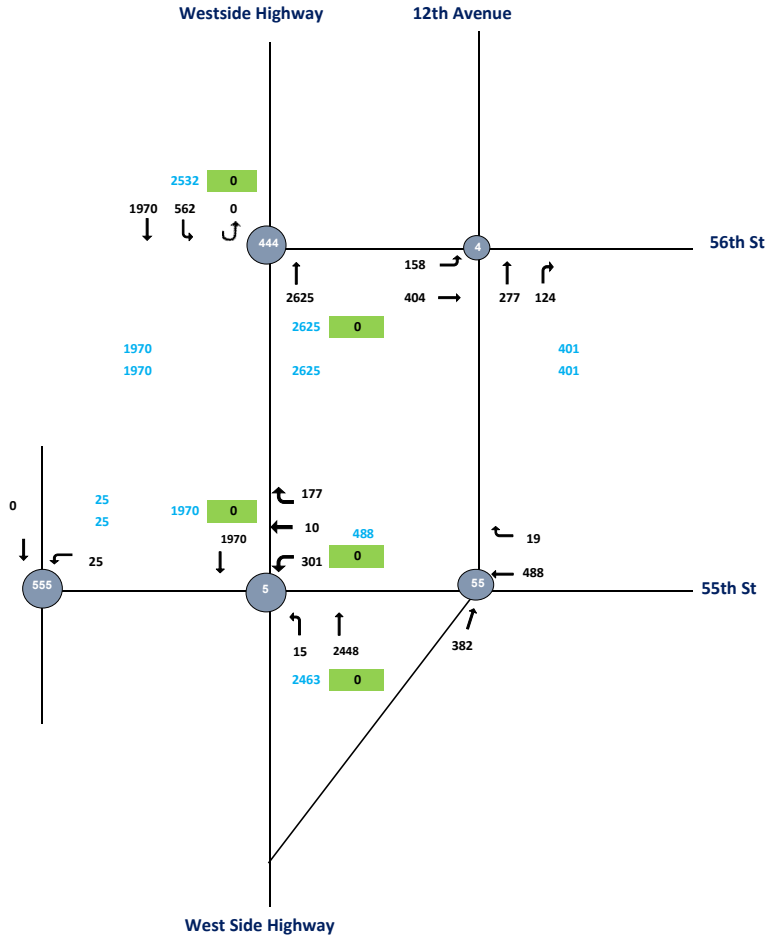

CBD Tolling
UW #5 - Traffic Flowmap
PM With Action



- Legend:**
- 1 - Intersection (2019 Collected Data)
 - 7 - Intersection (Uncollected Data)
 - 100 - ATR Volume
 - 100 - Approach Volume

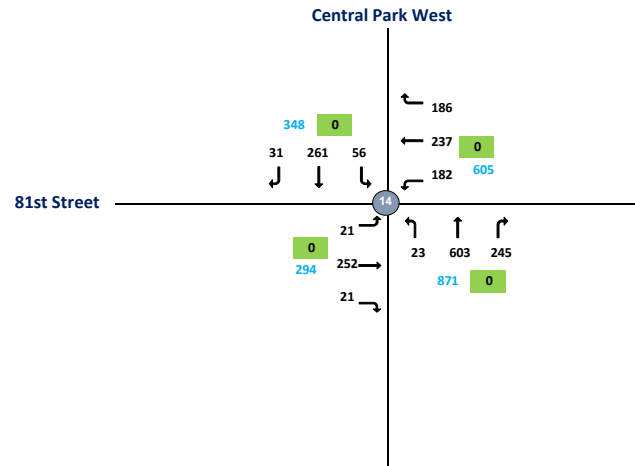

CBD Tolling
UW #6 - Traffic Flowmap
PM With Action



- Legend:**
- 1 - Intersection (2019 Collected Data)
 - 7 - Intersection (Uncollected Data)
 - 100 - ATR Volume
 - 100 - Approach Volume

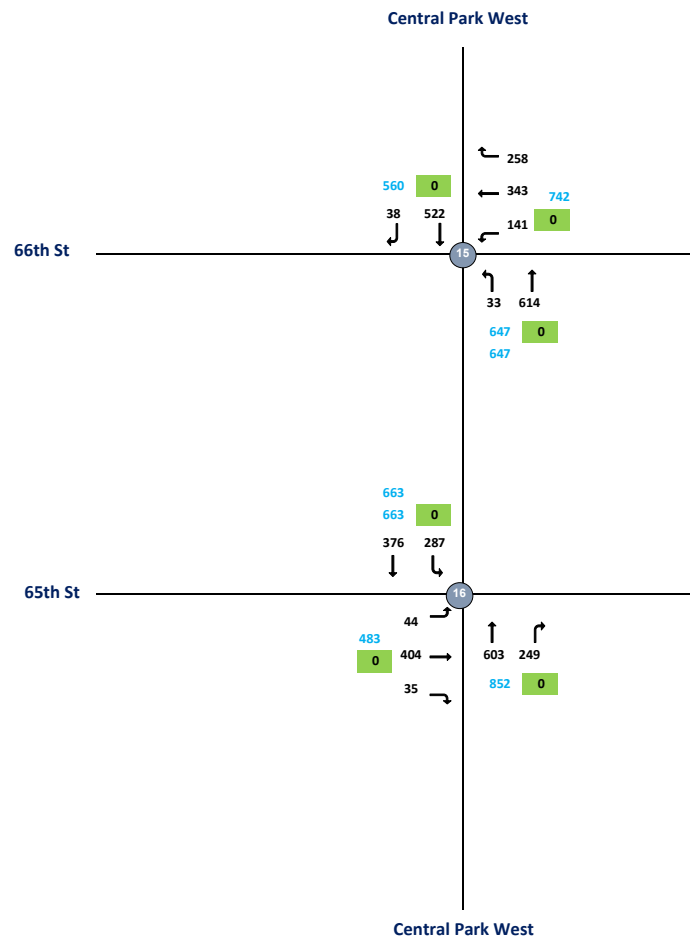

Intersection	Node	Approach	Total Vehicles					
			Inbound/Outbound					
			PM Peak Hour					
			L2	L	T	R	R2	Total
W 72nd St and West End St 2019 (TMC-042)	1							
W 72nd St	1	EB	0	13	62	48	0	
W 72nd St	1	WB	0	59	102	38	0	
West End St	1	NB	0	136	568	122	0	
West End St	1	SB	0	0	325	30	0	1503
W 61st St and West End St 2019 (TMC-043)	2							
W 61st St	2	EB	0	23	0	0	0	
W 61st St	2	WB	0	0	0	0	0	
West End St	2	NB	0	11	490	37	0	
West End St	2	SB	0	35	495	20	0	1111
W 79th St and Riverside Dr 2019 (TMC-044)	3	NEB						
W 79th St	3	EB	0	51	507	295	0	
W 79th St	3	WB	0	0	345	146	0	
Riverside Dr	3	NB	0	36	185	15	0	
Riverside Dr	3	SB	0	5	59	87	0	1731
W 79th St and Riverside Dr 2019 (TMC-044)	333							
W 79th St	333	EB	0	0	0	0	0	
W 79th St	333	WB	0	0	0	0	0	
Riverside Dr	333	NB	0	0	0	0	0	
Riverside Dr	333	SB	0	0	0	0	0	0
W 56th St and West Side Hwy 2019 (TMC-045)	4							
-	4	EB	0	158	404	0	0	
W 56th St	4	WB	0	0	0	0	0	
West Side Hwy	4	NB	0	0	277	124	0	
West Side Hwy	4	SB	0	0	0	0	0	963
W 56th St and West Side Hwy 2019 (TMC-045)	444							
-	444	EB	0	0	0	0	0	
W 56th St	444	WB	0	0	0	0	0	
West Side Hwy	444	NB	0	0	2625	0	0	
West Side Hwy	444	SB	0	562	1970	0	0	5157
W 55th St and West Side Hwy 2019 (TMC-046)	5							
-	5	EB	0	0	0	0	0	
W 55th St	5	WB	0	301	10	177	0	
West Side Hwy	5	NB	0	15	2448	0	0	
West Side Hwy	5	SB	0	0	1970	0	0	4921

W 55th St and West Side Hwy									
2019 (TMC-046 B B)	55								
-	55	EB	0	0	0	0	0		
W 55th St	55	WB	0	0	488	19	0		
West Side Hwy	55	NB	0	0	382	0	0		
West Side Hwy	55	SB	0	0	0	0	0		889
W 55th St and West Side Hwy									
2019 (TMC-046)	555								
-	555	EB	0	0	0	5	0		
W 55th St	555	WB	0	25	0	0	0		
West Side Hwy	555	NB	0	0	0	0	0		
West Side Hwy	555	SB	0	0	0	0	0		30
W 60th St and Broadway									
2019 (TMC-047)	6								
-	6	EB	0	0	0	0	0		
W 60th St	6	WB	0	0	0	0	0		
Broadway	6	NB	0	289	611	0	0		
Broadway	6	SB	0	0	599	62	0		1561
W 60th St and Columbus Ave									
2019 (TMC-048)	7								
W 60th St	7	EB	0	0	0	0	0		
W 60th St	7	WB	0	162	189	0	0		
Columbus Ave	7	NB	0	0	0	0	0		
Columbus Ave	7	SB	0	0	653	73	0		1077
W 60th St and 10th Ave									
2019 (TMC-049)	8								
W 60th St	8	EB	0	0	0	0	0		
W 60th St	8	WB	0	0	183	79	0		
10th Ave	8	NB	0	66	926	0	0		
10th Ave	8	SB	0	0	0	0	0		1254
W 60th St and 11th Ave									
2019 (TMC-050)	9								
W 60th St	9	EB	0	10	0	25	0		
W 60th St	9	WB	0	116	37	96	0		
11th Ave	9	NB	0	7	432	0	0		
11th Ave	9	SB	0	0	488	7	0		1218
W 61st St and 10th Ave									
2019 (TMC-051)	10								
W 61st St	10	EB	0	60	12	0	0		
W 61st St	10	WB	0	0	0	19	0		
10th Ave	10	NB	0	0	991	14	0		
10th Ave	10	SB	0	0	0	0	0		1096

W 61st St and Columbus Ave									
2019 (TMC-052)	11								
-	11	EB	0	0	0	0	0		
W 61st St	11	WB	0	0	0	0	0		
Columbus Ave	11	NB	0	0	0	0	0		
Columbus Ave	11	SB	0	141	726	0	0		867
W 61st St and Broadway									
2019 (TMC-053)	12								
W 61st St	12	EB	0	27	29	85	0		
W 61st St	12	WB	0	0	0	0	0		
Broadway	12	NB	0	0	601	10	0		
Broadway	12	SB	0	4	576	0	0		1332
Central Park and W 61st St									
2019 (TMC-054)	13								
W 61st St	13	EB	0	43	0	0	0		
-	13	WB	0	0	0	0	0		
Central Park	13	NB	0	0	761	0	0		
Central Park	13	SB	0	0	0	0	0		804
Central Park and W 81st St									
2019 (TMC-055)	14								
W 81st St	14	EB	0	21	252	21	0		
W 79th St Transverse	14	WB	0	182	237	186	0		
Central Park	14	NB	0	23	603	245	0		
Central Park	14	SB	0	56	261	31	0		2118
Central Park West and W 66th St									
2019 (TMC-056)	15								
W 66th St	15	EB	0	0	0	0	0		
W 66th St	15	WB	0	141	343	258	0		
Central Park West	15	NB	0	33	614	0	0		
Central Park West	15	SB	0	0	522	38	0		1949
Central Park West and W 65th St									
2019 (TMC-057)	16								
W 65th St	16	EB	0	44	404	35	0		
W 65th St	16	WB	0	0	0	0	0		
Central Park West	16	NB	0	0	603	249	0		
Central Park West	16	SB	0	287	376	0	0		1998

CBD Tolling
UW #1 - Traffic Flowmap
LN With Action



- Legend:**
- 1 - Intersection (2019 Collected Data)
 - 7 - Intersection (Uncollected Data)
 - 100 - ATR Volume
 - 100 - Approach Volume

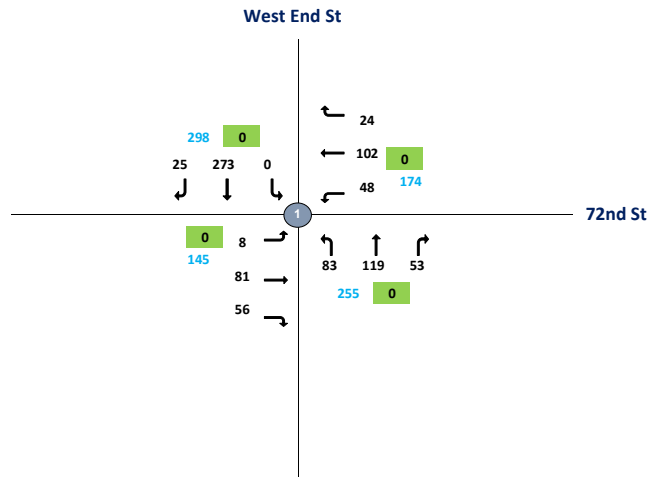

CBD Tolling
UW #2 - Traffic Flowmap
LN With Action



- Legend:**
- 1 - Intersection (2019 Collected Data)
 - 2 - Intersection (Uncollected Data)
 - 100 - ATR Volume
 - 100 - Approach Volume

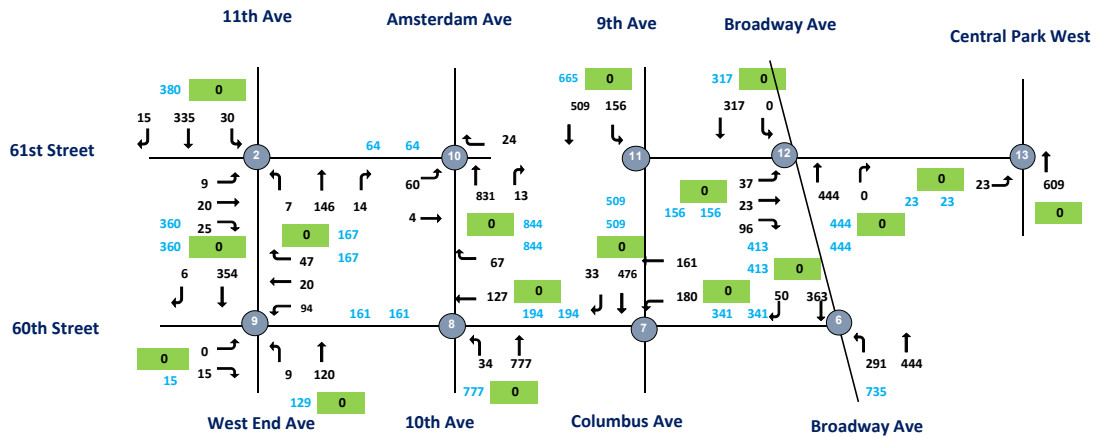

CBD Tolling
UW #3 - Traffic Flowmap
LN With Action



- Legend:**
- 1 - Intersection (2019 Collected Data)
 - 7 - Intersection (Uncollected Data)
 - 100 - ATR Volume
 - 100 - Approach Volume

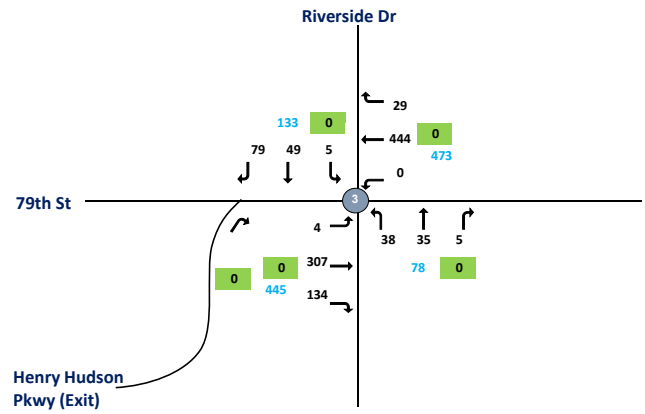

CBD Tolling
UW #4 - Traffic Flowmap
LN With Action



- Legend:**
- - Intersection (2019 Collected Data)
 - - Intersection (Uncollected Data)
 - 100 - ATR Volume
 - 100 - Approach Volume

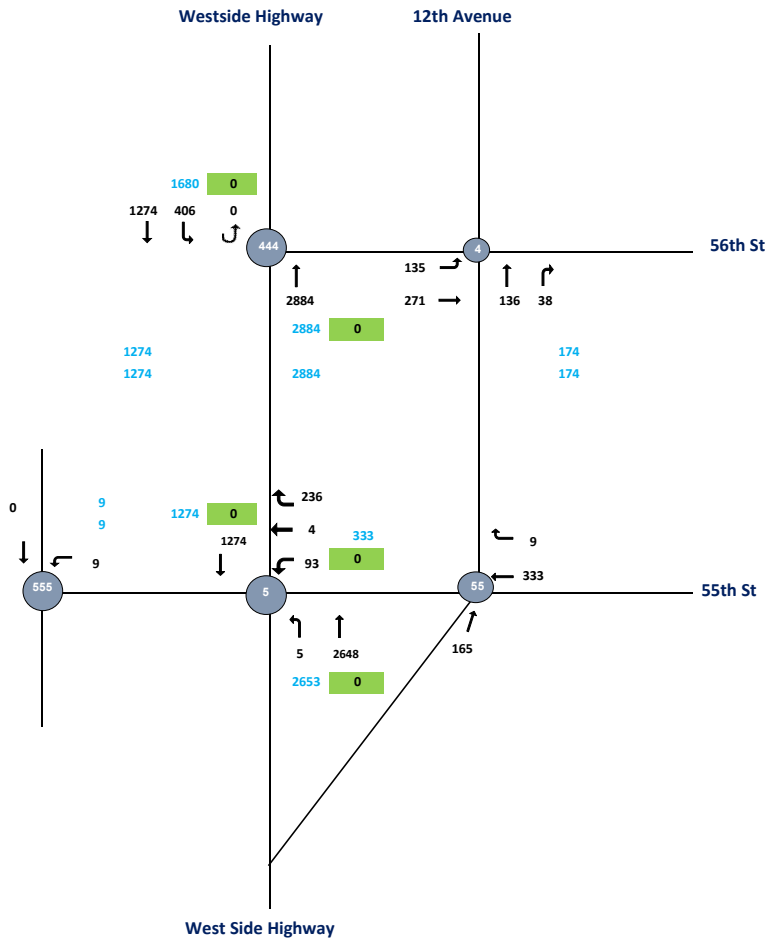

CBD Tolling
UW #5 - Traffic Flowmap
LN With Action



- Legend:**
- 1 - Intersection (2019 Collected Data)
 - 7 - Intersection (Uncollected Data)
 - 100 - ATR Volume
 - 100 - Approach Volume

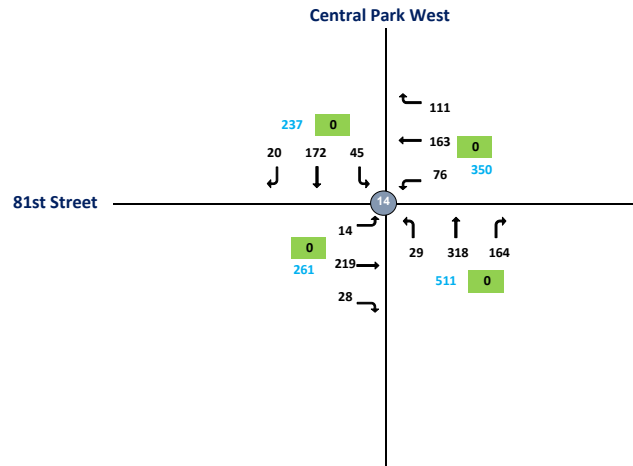

CBD Tolling
UW #6 - Traffic Flowmap
LN With Action



- Legend:**
- 1 - Intersection (2019 Collected Data)
 - 7 - Intersection (Uncollected Data)
 - 100 - ATR Volume
 - 100 - Approach Volume

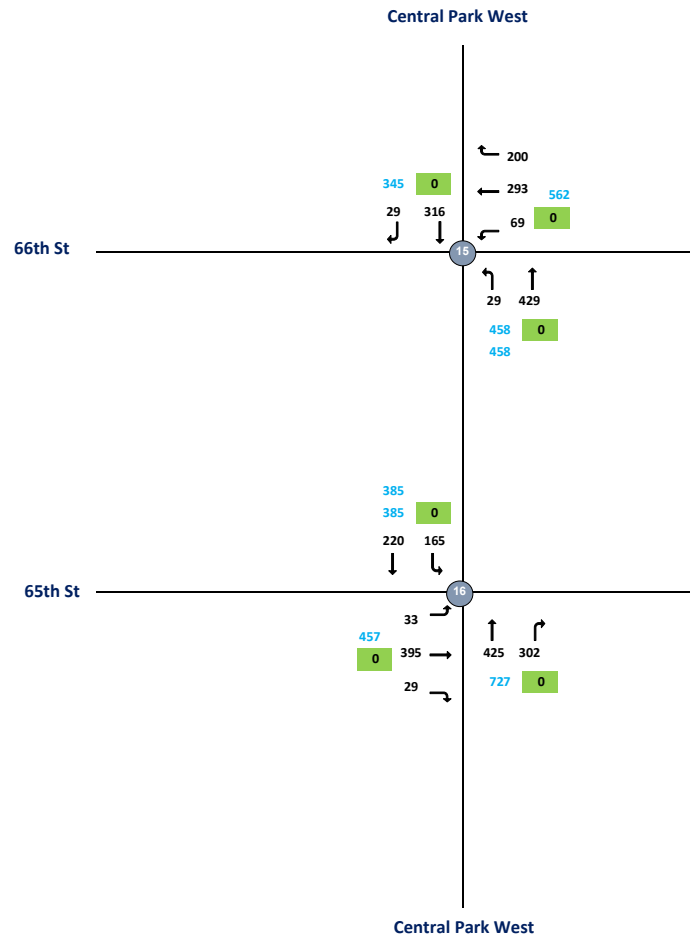

Intersection	Node	Approach	Total Vehicles					
			Inbound/Outbound					
			LN Peak Hour					
			L2	L	T	R	R2	Total
W 72nd St and West End St 2019 (TMC-042)	1							
W 72nd St	1	EB	0	8	81	56	0	
W 72nd St	1	WB	0	48	102	24	0	
West End St	1	NB	0	83	119	53	0	
West End St	1	SB	0	0	273	25	0	872
W 61st St and West End St 2019 (TMC-043)	2							
W 61st St	2	EB	0	9	20	25	0	
W 61st St	2	WB	0	0	0	0	0	
West End St	2	NB	0	7	146	14	0	
West End St	2	SB	0	30	335	15	0	601
W 79th St and Riverside Dr 2019 (TMC-044)	3	NEB						
W 79th St	3	EB	0	4	307	134	0	
W 79th St	3	WB	0	0	444	29	0	
Riverside Dr	3	NB	0	38	35	5	0	
Riverside Dr	3	SB	0	5	49	79	0	1129
W 79th St and Riverside Dr 2019 (TMC-044)	333							
W 79th St	333	EB	0	0	0	0	0	
W 79th St	333	WB	0	0	0	0	0	
Riverside Dr	333	NB	0	0	0	0	0	
Riverside Dr	333	SB	0	0	0	0	0	0
W 56th St and West Side Hwy 2019 (TMC-045)	4							
-	4	EB	0	135	271	0	0	
W 56th St	4	WB	0	0	0	0	0	
West Side Hwy	4	NB	0	0	136	38	0	
West Side Hwy	4	SB	0	0	0	0	0	580
W 56th St and West Side Hwy 2019 (TMC-045)	444							
-	444	EB	0	0	0	0	0	
W 56th St	444	WB	0	0	0	0	0	
West Side Hwy	444	NB	0	0	2884	0	0	
West Side Hwy	444	SB	0	406	1274	0	0	4564
W 55th St and West Side Hwy 2019 (TMC-046)	5							
-	5	EB	0	0	0	0	0	
W 55th St	5	WB	0	93	4	236	0	
West Side Hwy	5	NB	0	5	2648	0	0	
West Side Hwy	5	SB	0	0	1274	0	0	4260

W 55th St and West Side Hwy									
2019 (TMC-046 B B)		55							
-	55	EB	0	0	0	0	0		
W 55th St	55	WB	0	0	333	9	0		
West Side Hwy	55	NB	0	0	165	0	0		
West Side Hwy	55	SB	0	0	0	0	0		507
W 55th St and West Side Hwy									
2019 (TMC-046)		555							
-	555	EB	0	0	0	0	0		
W 55th St	555	WB	0	9	0	0	0		
West Side Hwy	555	NB	0	0	0	0	0		
West Side Hwy	555	SB	0	0	0	0	0		9
W 60th St and Broadway									
2019 (TMC-047)		6							
-	6	EB	0	0	0	0	0		
W 60th St	6	WB	0	0	0	0	0		
Broadway	6	NB	0	291	444	0	0		
Broadway	6	SB	0	0	363	50	0		1148
W 60th St and Columbus Ave									
2019 (TMC-048)		7							
W 60th St	7	EB	0	0	0	0	0		
W 60th St	7	WB	0	180	161	0	0		
Columbus Ave	7	NB	0	0	0	0	0		
Columbus Ave	7	SB	0	0	476	33	0		850
W 60th St and 10th Ave									
2019 (TMC-049)		8							
W 60th St	8	EB	0	0	0	0	0		
W 60th St	8	WB	0	0	127	67	0		
10th Ave	8	NB	0	34	777	0	0		
10th Ave	8	SB	0	0	0	0	0		1005
W 60th St and 11th Ave									
2019 (TMC-050)		9							
W 60th St	9	EB	0	0	0	15	0		
W 60th St	9	WB	0	94	20	47	0		
11th Ave	9	NB	0	9	120	0	0		
11th Ave	9	SB	0	0	354	6	0		665
W 61st St and 10th Ave									
2019 (TMC-051)		10							
W 61st St	10	EB	0	60	4	0	0		
W 61st St	10	WB	0	0	0	24	0		
10th Ave	10	NB	0	0	831	13	0		
10th Ave	10	SB	0	0	0	0	0		932

W 61st St and Columbus Ave									
2019 (TMC-052)	11								
-	11	EB	0	0	0	0	0		
W 61st St	11	WB	0	0	0	0	0		
Columbus Ave	11	NB	0	0	0	0	0		
Columbus Ave	11	SB	0	156	509	0	0		665
W 61st St and Broadway									
2019 (TMC-053)	12								
W 61st St	12	EB	0	37	23	96	0		
W 61st St	12	WB	0	0	0	0	0		
Broadway	12	NB	0	0	444	0	0		
Broadway	12	SB	0	0	317	0	0		917
Central Park and W 61st St									
2019 (TMC-054)	13								
W 61st St	13	EB	0	23	0	0	0		
-	13	WB	0	0	0	0	0		
Central Park	13	NB	0	0	609	0	0		
Central Park	13	SB	0	0	0	0	0		632
Central Park and W 81st St									
2019 (TMC-055)	14								
W 81st St	14	EB	0	14	219	28	0		
W 79th St Transverse	14	WB	0	76	163	111	0		
Central Park	14	NB	0	29	318	164	0		
Central Park	14	SB	0	45	172	20	0		1359
Central Park West and W 66th St									
2019 (TMC-056)	15								
W 66th St	15	EB	0	0	0	0	0		
W 66th St	15	WB	0	69	293	200	0		
Central Park West	15	NB	0	29	429	0	0		
Central Park West	15	SB	0	0	316	29	0		1365
Central Park West and W 65th St									
2019 (TMC-057)	16								
W 65th St	16	EB	0	33	395	29	0		
W 65th St	16	WB	0	0	0	0	0		
Central Park West	16	NB	0	0	425	302	0		
Central Park West	16	SB	0	165	220	0	0		1569

CBD Tolling
LDR - Traffic Flowmap
AM Existing



- Legend:**
- 1 - Intersection (2019 Collected Data)
 - 7 - Intersection (Uncollected Data)
 - 100 - ATR Volume
 - 100 - Approach Volume

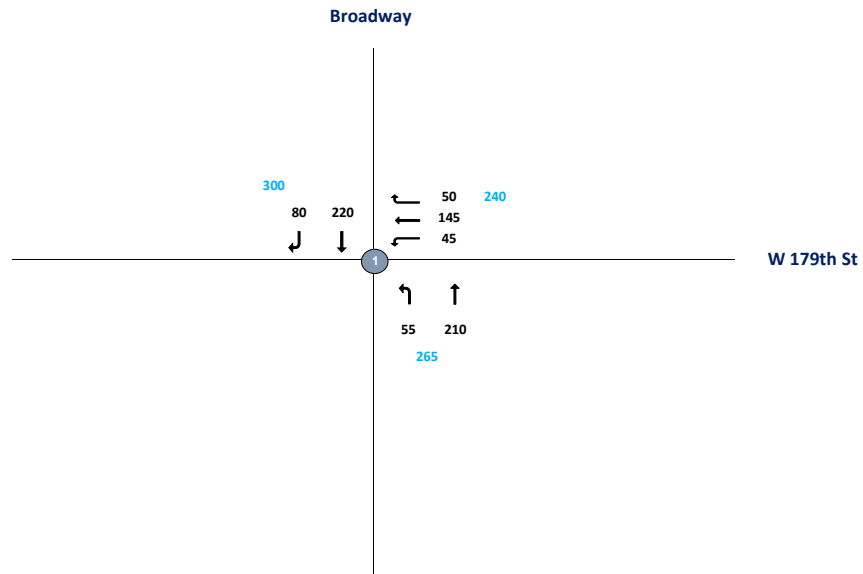

LDR

7:00 AM

Intersection	Node	Approach	Total Vehicles						Total
			Inbound/Outbound						
			AM Peak Hour						
			L2	L	T	R	R2		
Broadway & W 179th 2021 (LDR-01)	1								
W 179th St	1	EB	0	0	0	0	0		
W 179th St	1	WB	0	45	145	50	0		
Broadway	1	NB	0	55	210	0	0		
Broadway	1	SB	0	0	220	80	0	805	

CBD Tolling
LDR - Traffic Flowmap
MD Existing



- Legend:**
- 1 - Intersection (2019 Collected Data)
 - 7 - Intersection (Uncollected Data)
 - 100 - ATR Volume
 - 100 - Approach Volume

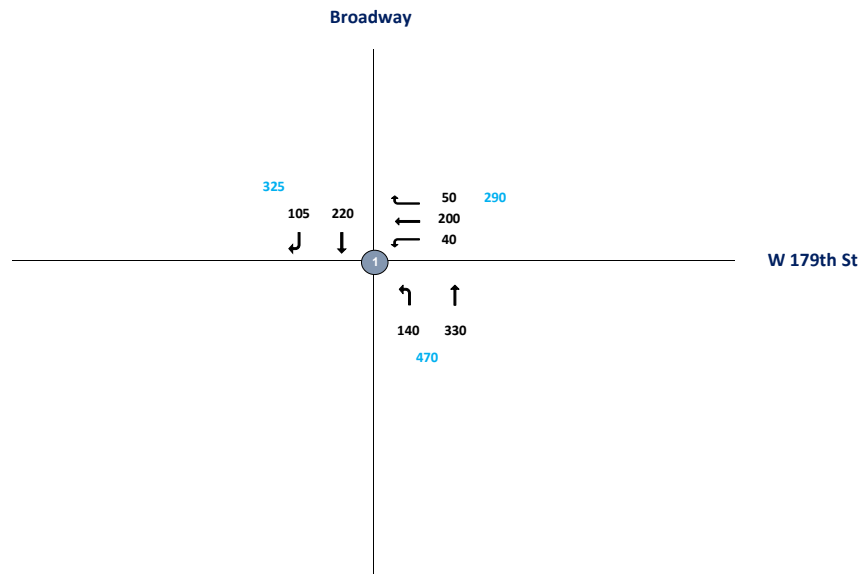

LDR

3:00 PM

Intersection	Node	Approach	Total Vehicles					
			Inbound/Outbound					
			MD Peak Hour					
			L2	L	T	R	R2	Total
Broadway & W 179th 2021 (LDR-01)	1							
W 179th St	1	EB	0	0	0	0	0	
W 179th St	1	WB	0	40	200	50	0	
Broadway	1	NB	0	140	330	0	0	
Broadway	1	SB	0	0	220	105	0	1085

CBD Tolling
LDR - Traffic Flowmap
PM Existing



- Legend:**
- 1 - Intersection (2019 Collected Data)
 - 7 - Intersection (Uncollected Data)
 - 100 - ATR Volume
 - 100 - Approach Volume

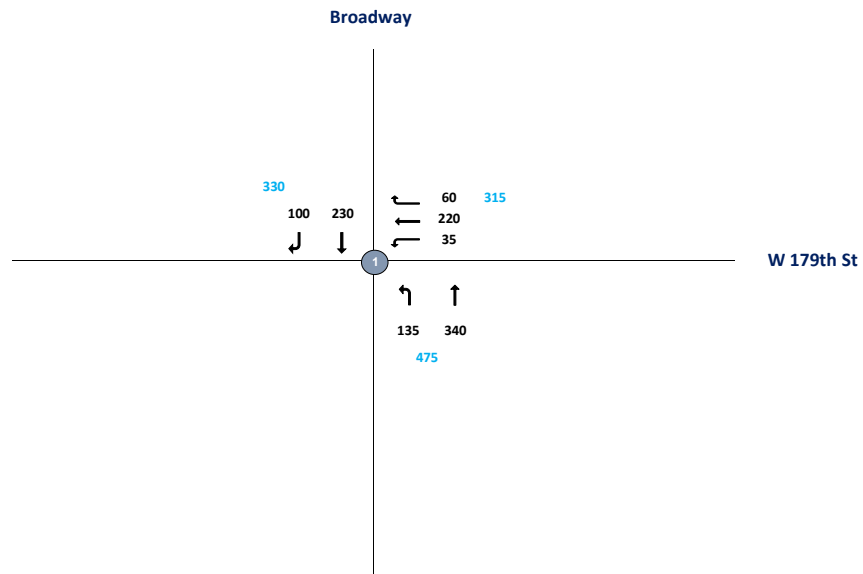

LDR

5:00 PM

Intersection	Node	Approach	Total Vehicles					
			Inbound/Outbound					
			PM Peak Hour					
			L2	L	T	R	R2	Total
12th Ave & 24th Street 2019 (TMC-065)	1							
24th Street	1	EB	0	0	0	0	0	
24th Street	1	WB	0	235	0	275	0	
12th Ave	1	NB	0	0	2365	10	0	
12th Ave	1	SB	0	85	2060	0	0	5030

CBD Tolling
LDR - Traffic Flowmap
AM No-Action Increment



- Legend:**
- 1 - Intersection (2019 Collected Data)
 - 7 - Intersection (Uncollected Data)
 - 100 - ATR Volume
 - 100 - Approach Volume

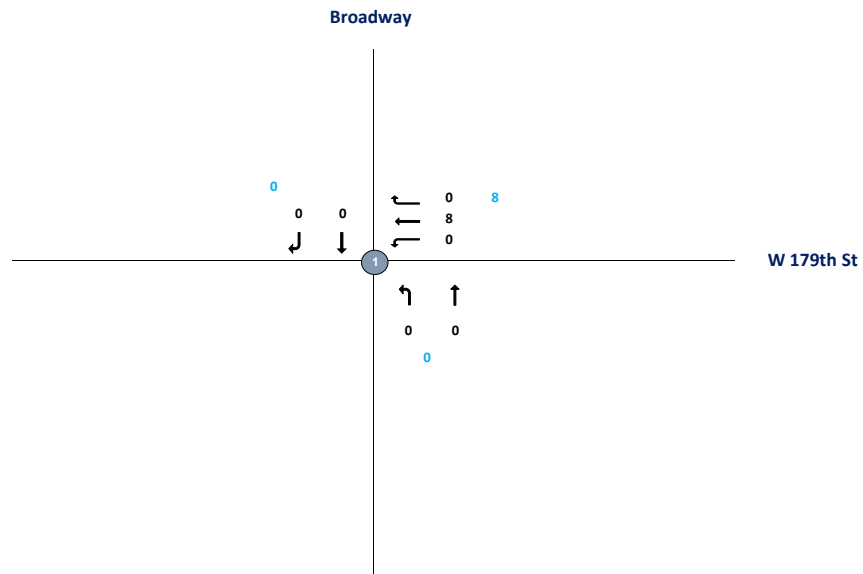

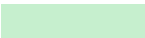

Intersection	Node	Approach	Total Vehicles						
			Inbound/Outbound						
			AM Peak Hour						
			L2	L	T	R	R2	Total	
12th Ave & 24th Street									
2019 (TMC-065)	1								
24th Street	1	EB	0	0	0	0	0		
24th Street	1	WB	0	0	0	0	0		
12th Ave	1	NB	0	0	9	0	0		
12th Ave	1	SB	0	-1	-10	0	0		-2

CBD Tolling
LDR - Traffic Flowmap
AM No-Action



- Legend:**
- Intersection (2019 Collected Data)
 - Intersection (Uncollected Data)
 - ATR Volume
 - Approach Volume

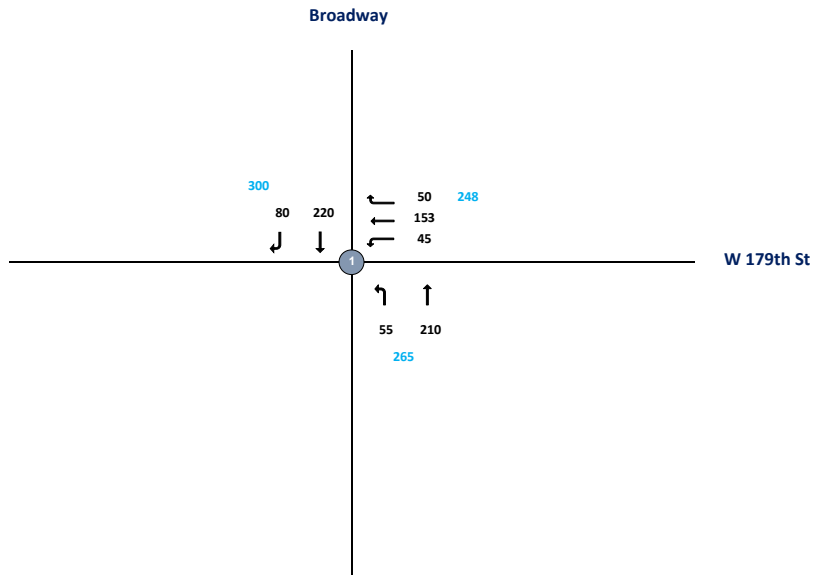

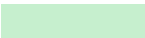

Intersection	Node	Approach	Total Vehicles					
			Inbound/Outbound					
			AM Peak Hour					
			L2	L	T	R	R2	Total
12th Ave & 24th Street 2019 (TMC-065)	1							
24th Street	1	EB	0	0	0	0	0	
24th Street	1	WB	0	200	0	165	0	
12th Ave	1	NB	0	0	1874	20	0	
12th Ave	1	SB	0	109	1765	0	0	4133

CBD Tolling
LDR - Traffic Flowmap
MD No-Action Increment



- Legend:**
- 1 - Intersection (2019 Collected Data)
 - 7 - Intersection (Uncollected Data)
 - 100 - ATR Volume
 - 100 - Approach Volume

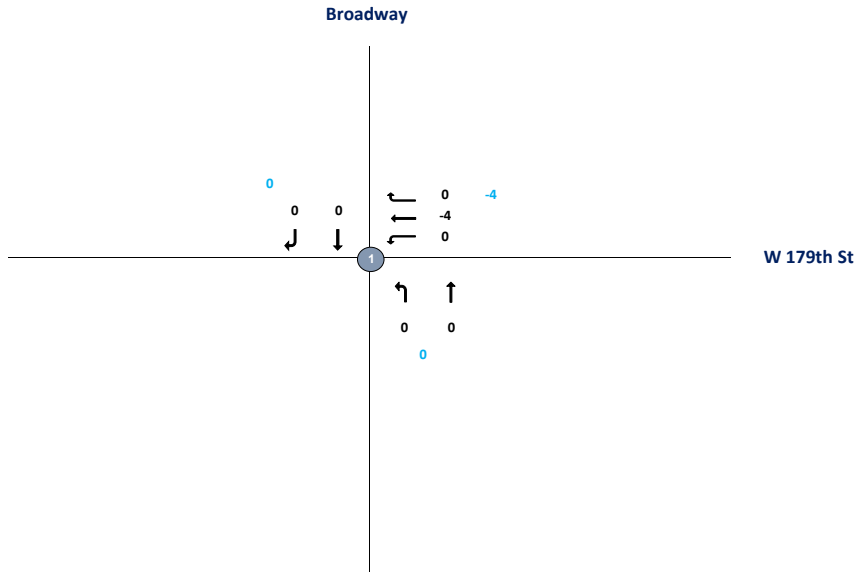

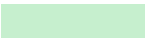

Intersection	Node	Approach	Total Vehicles					
			Inbound/Outbound					
			MD Peak Hour					
			L2	L	T	R	R2	Total
12th Ave & 24th Street 2019 (TMC-065)	1							
24th Street	1	EB	0	0	0	0	0	
24th Street	1	WB	0	0	0	0	0	
12th Ave	1	NB	0	0	18	0	0	
12th Ave	1	SB	0	0	-4	0	0	14

CBD Tolling
LDR - Traffic Flowmap
MD No-Action



- Legend:**
- Intersection (2019 Collected Data)
 - Intersection (Uncollected Data)
 - ATR Volume
 - Approach Volume

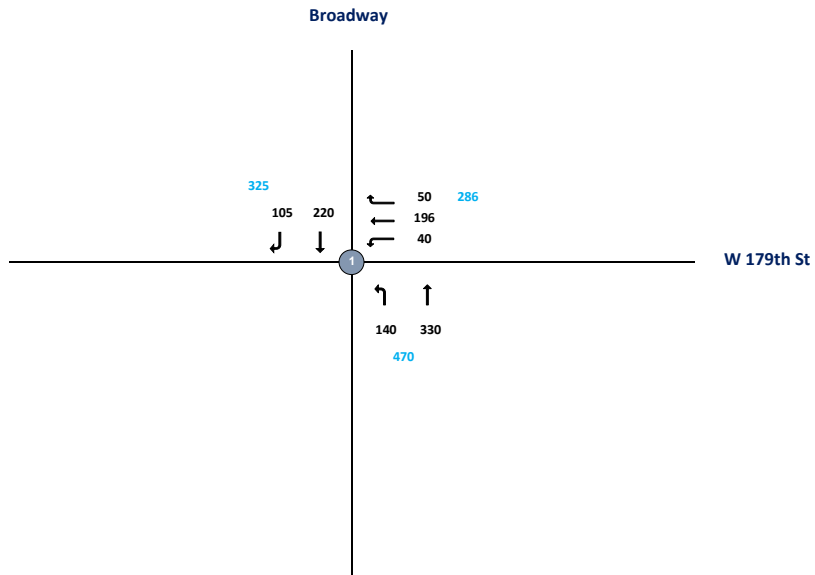

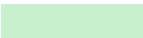

Intersection	Node	Approach	Total Vehicles					
			Inbound/Outbound					
			MD Peak Hour					
			L2	L	T	R	R2	Total
12th Ave & 24th Street 2019 (TMC-065)	1							
24th Street	1	EB	0	0	0	0	0	
24th Street	1	WB	0	130	0	195	0	
12th Ave	1	NB	0	0	1523	20	0	
12th Ave	1	SB	0	80	1536	0	0	3484

CBD Tolling
LDR - Traffic Flowmap
PM No-Action Increment



- Legend:**
- Intersection (2019 Collected Data)
 - Intersection (Uncollected Data)
 - ATR Volume
 - Approach Volume

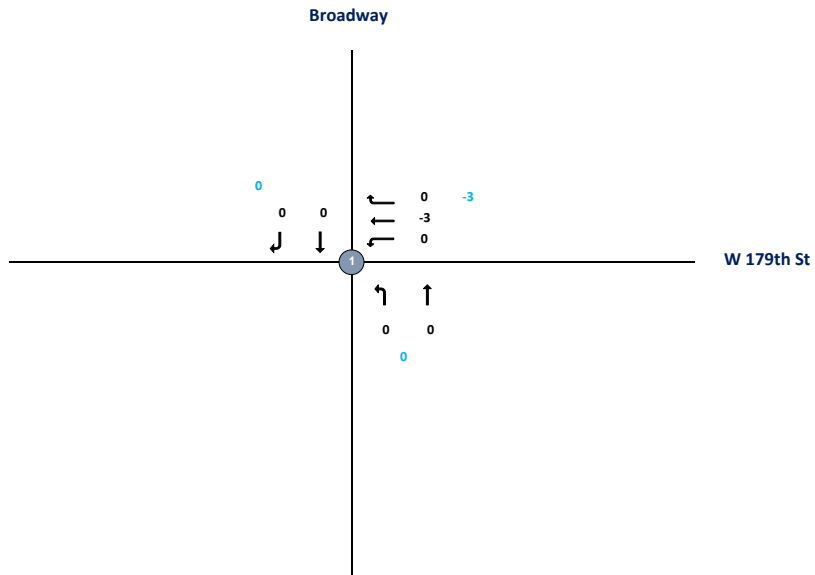

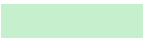

Intersection	Node	Approach	Total Vehicles					
			Inbound/Outbound					
			PM Peak Hour					
			L2	L	T	R	R2	Total
12th Ave & 24th Street 2019 (TMC-065)	1							
24th Street	1	EB	0	0	0	0	0	
24th Street	1	WB	0	0	0	0	0	
12th Ave	1	NB	0	0	-42	0	0	
12th Ave	1	SB	0	0	-12	0	0	-54

CBD Tolling
LDR - Traffic Flowmap
PM No-Action



- Legend:**
- 1 - Intersection (2019 Collected Data)
 - 7 - Intersection (Uncollected Data)
 - 100 - ATR Volume
 - 100 - Approach Volume

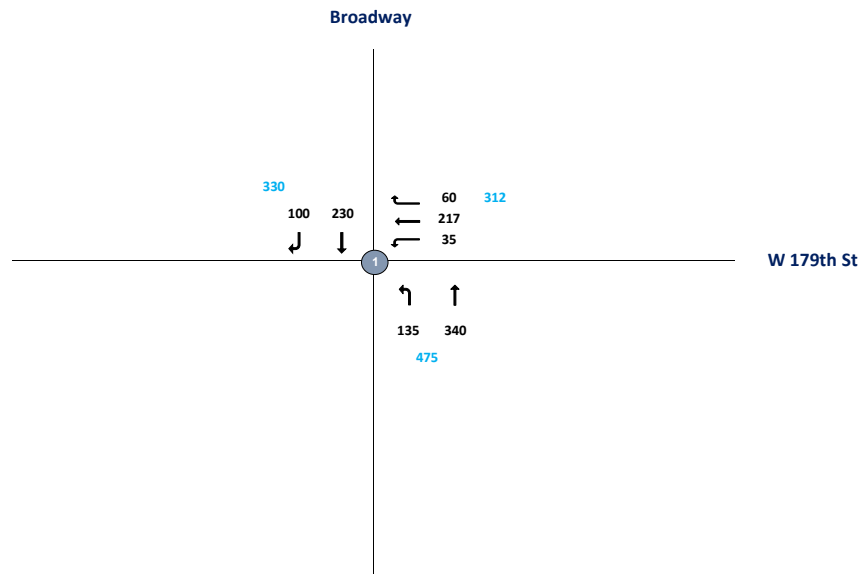

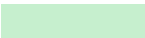

Intersection	Node	Approach	Total Vehicles						
			Inbound/Outbound						
			PM Peak Hour						
			L2	L	T	R	R2	Total	
12th Ave & 24th Street 2019 (TMC-065)	1								
24th Street	1	EB	0	0	0	0	0		
24th Street	1	WB	0	235	0	275	0		
12th Ave	1	NB	0	0	2323	10	0		
12th Ave	1	SB	0	85	2048	0	0	4976	

CBD Tolling
LDR - Traffic Flowmap
AM With-Action Increment



- Legend:**
- Intersection (2019 Collected Data)
 - Intersection (Uncollected Data)
 - ATR Volume
 - Approach Volume

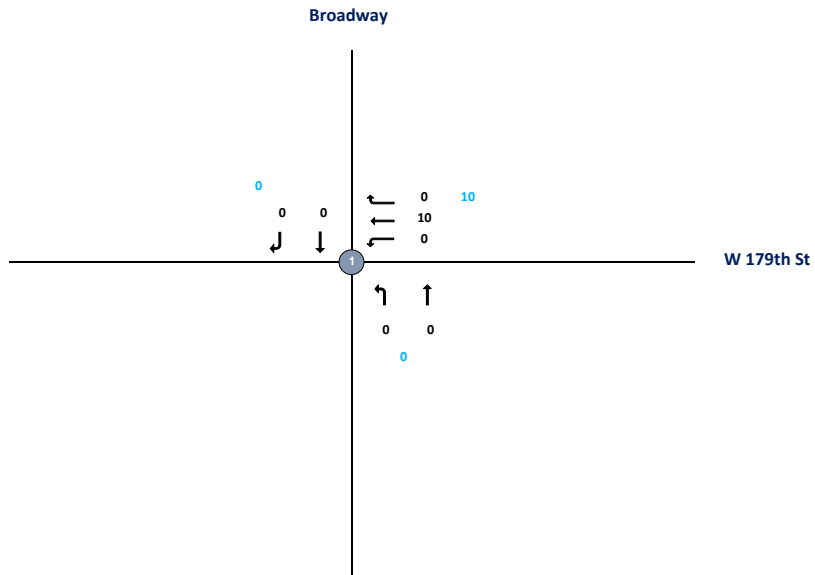

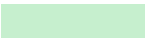

Intersection	Node	Approach	Total Vehicles					
			Inbound/Outbound					
			AM Peak Hour					
			L2	L	T	R	R2	Total
12th Ave & 24th Street 2019 (TMC-065)	1							
24th Street	1	EB	0	0	0	0	0	
24th Street	1	WB	0	0	0	0	0	
12th Ave	1	NB	0	0	-20	0	0	
12th Ave	1	SB	0	-6	-102	0	0	-128

CBD Tolling
LDR - Traffic Flowmap
AM With-Action



- Legend:**
- Intersection (2019 Collected Data)
 - Intersection (Uncollected Data)
 - ATR Volume
 - Approach Volume

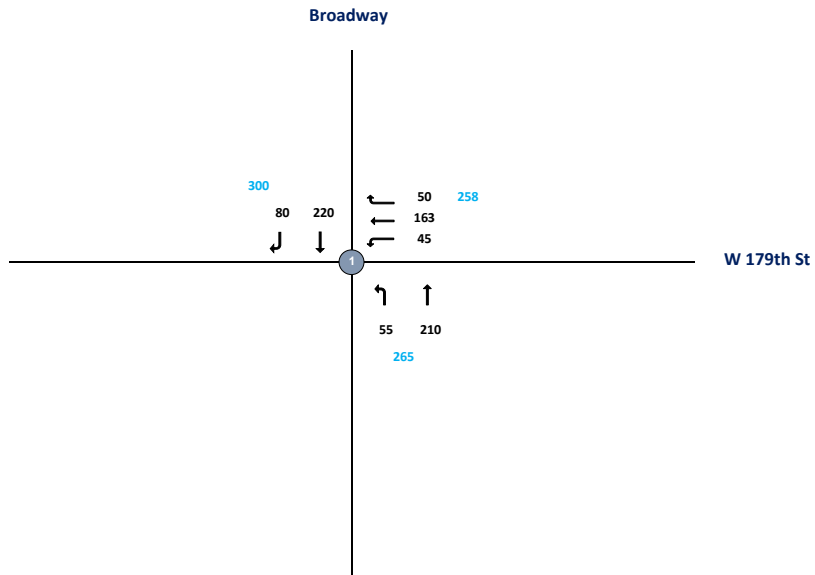

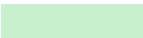

Intersection	Node	Approach	Total Vehicles					
			Inbound/Outbound					
			AM Peak Hour					
			L2	L	T	R	R2	Total
12th Ave & 24th Street 2019 (TMC-065)	1							
24th Street	1	EB	0	0	0	0	0	
24th Street	1	WB	0	200	0	165	0	
12th Ave	1	NB	0	0	1854	20	0	
12th Ave	1	SB	0	103	1663	0	0	4005

CBD Tolling
LDR - Traffic Flowmap
MD With-Action Increment



- Legend:**
- 1 - Intersection (2019 Collected Data)
 - 7 - Intersection (Uncollected Data)
 - 100 - ATR Volume
 - 100 - Approach Volume

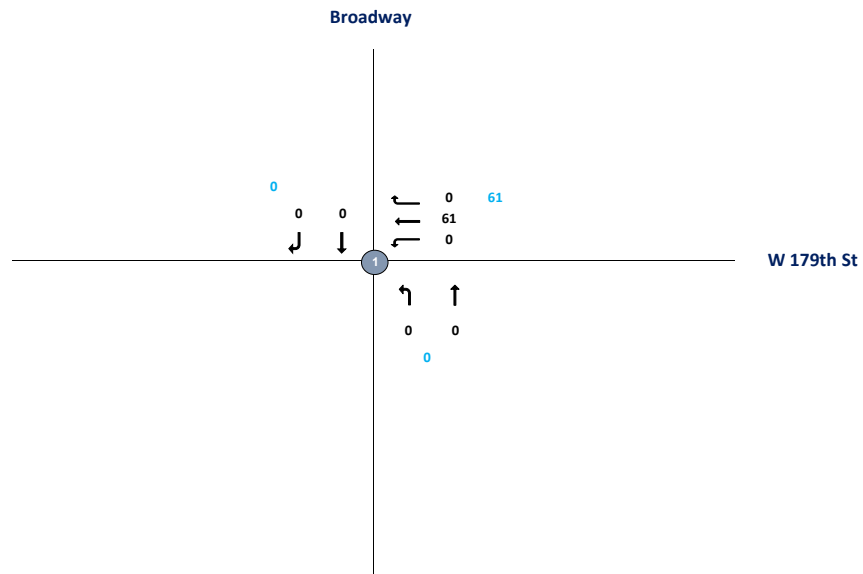

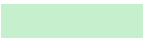

Intersection	Node	Approach	Total Vehicles					
			Inbound/Outbound					
			MD Peak Hour					
			L2	L	T	R	R2	Total
12th Ave & 24th Street 2019 (TMC-065)	1							
24th Street	1	EB	0	0	0	0	0	
24th Street	1	WB	0	0	0	0	0	
12th Ave	1	NB	0	0	1	0	0	
12th Ave	1	SB	0	-7	-128	0	0	-134

CBD Tolling
LDR - Traffic Flowmap
MD With-Action



- Legend:**
- Intersection (2019 Collected Data)
 - Intersection (Uncollected Data)
 - ATR Volume
 - Approach Volume

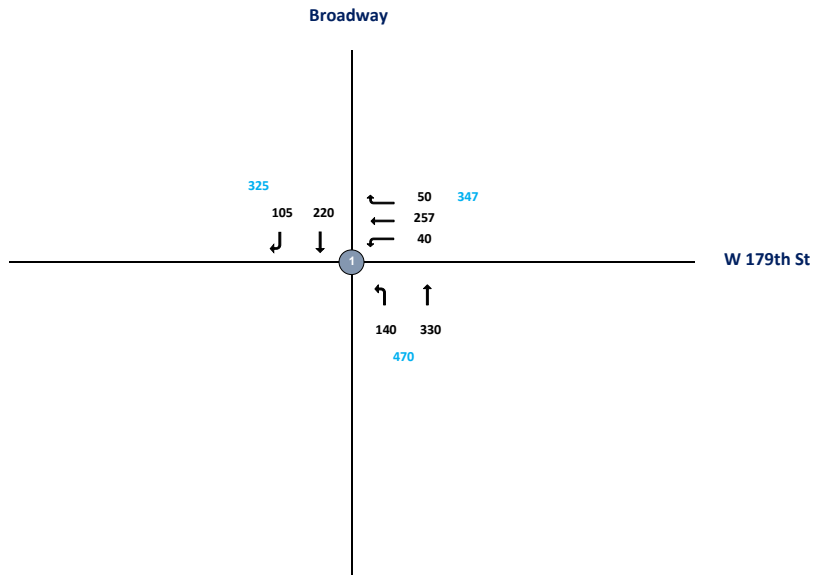

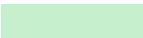

Intersection	Node	Approach	Total Vehicles					
			Inbound/Outbound					
			AM Peak Hour					
			L2	L	T	R	R2	Total
12th Ave & 24th Street 2019 (TMC-065)	1							
24th Street	1	EB	0	0	0	0	0	
24th Street	1	WB	0	130	0	195	0	
12th Ave	1	NB	0	0	1524	20	0	
12th Ave	1	SB	0	73	1408	0	0	3350

CBD Tolling
LDR - Traffic Flowmap
PM With-Action Increment



- Legend:**
- 1 - Intersection (2019 Collected Data)
 - 7 - Intersection (Uncollected Data)
 - 100 - ATR Volume
 - 100 - Approach Volume

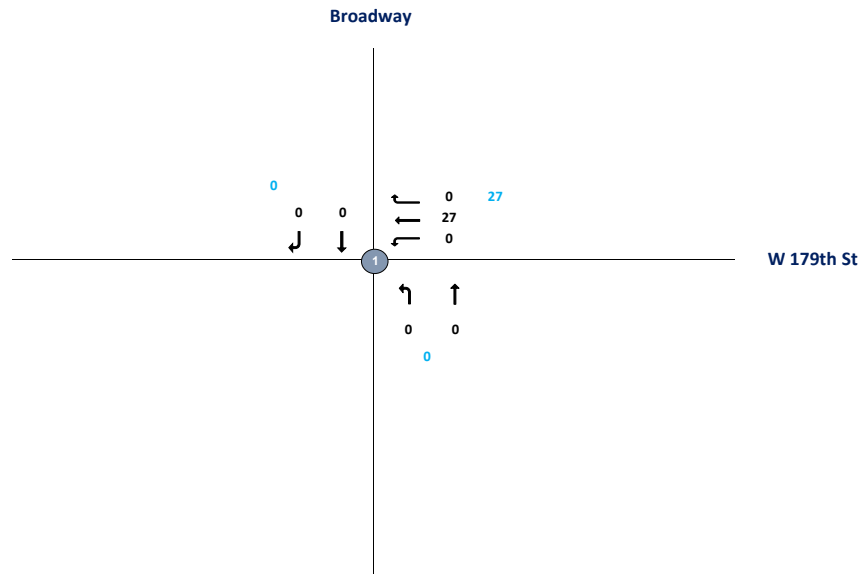

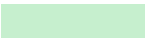

Intersection	Node	Approach	Total Vehicles					
			Inbound/Outbound					
			PM Peak Hour					
			L2	L	T	R	R2	Total
12th Ave & 24th Street 2019 (TMC-065)	1							
24th Street	1	EB	0	0	0	0	0	
24th Street	1	WB	0	0	0	0	0	
12th Ave	1	NB	0	0	-69	0	0	
12th Ave	1	SB	0	-8	-188	0	0	-265

CBD Tolling
LDR - Traffic Flowmap
PM With-Action



- Legend:**
- 1 - Intersection (2019 Collected Data)
 - 7 - Intersection (Uncollected Data)
 - 100 - ATR Volume
 - 100 - Approach Volume

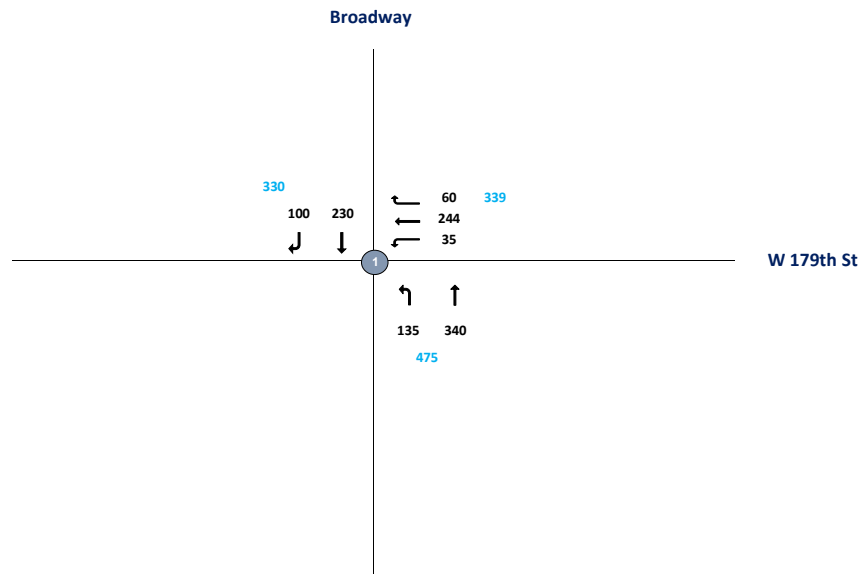

Intersection	Node	Approach	Total Vehicles					
			Inbound/Outbound					
			PM Peak Hour					
			L2	L	T	R	R2	Total
12th Ave & 24th Street 2019 (TMC-065)	1							
24th Street	1	EB	0	0	0	0	0	
24th Street	1	WB	0	235	0	275	0	
12th Ave	1	NB	0	0	2254	10	0	
12th Ave	1	SB	0	77	1860	0	0	4711

CBD Tolling
LES - Traffic Flowmap
AM Existing



- Legend:**
- 1 - Intersection (2019 Collected Data)
 - 7 - Intersection (Uncollected Data)
 - 100 - ATR Volume
 - 100 - Approach Volume

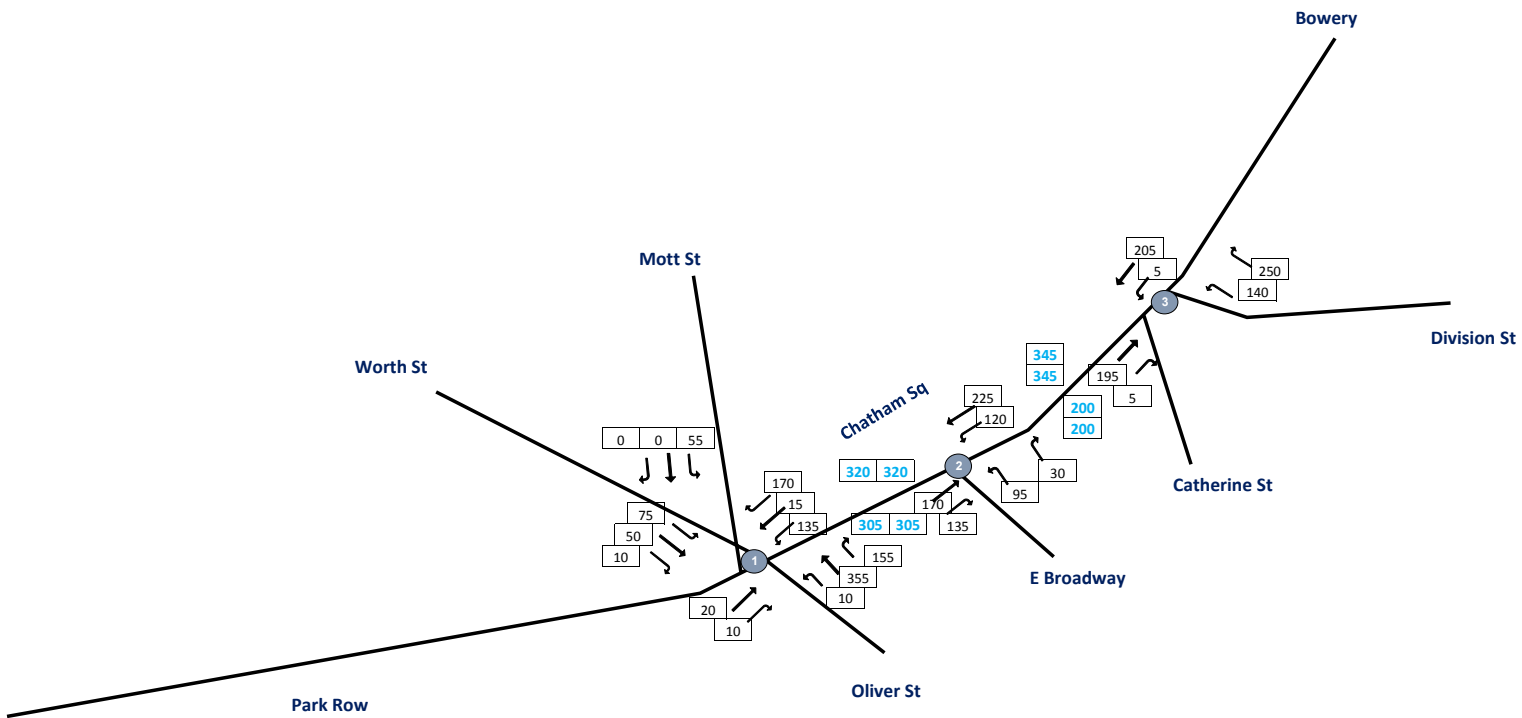

LES

8:00 AM

Intersection	Node	Approach	Total Vehicles					
			Inbound/Outbound					
			AM Peak Hour					
			L2	L	T	R	R2	Total
Worth St/Oliver St/Mott St & Chatham Square/Park Row 2022 (LES-01)								
Mott St	1	SW	55	0	0	0	0	
Park Row	1	EB	0	0	20	10	0	
Chatham Sq	1	WB	0	135	15	170	0	
Oliver St	1	NB	0	10	355	0	155	
Worth St	1	SB	0	75	50	10	0	1060
E Broadway & Chatham Sq 2022 (LES-02)								
Chatham Sq	2	EB	0	0	170	135	0	
Chatham Sq	2	WB	0	120	225	0	0	
E Broadway	2	NB	0	95	0	30	0	
	2	SB	0	0	0	0	0	775
Division St/Doyers St/Catherine St & Chatham Square/Bowery 2022 (LES-03)								
Chatham Sq	3	EB	0	0	195	0	5	
Bowery	3	WB	0	5	205	0	0	
Division St	3	NB	0	140	0	250	0	
	3	SB	0	0	0	0	0	800

CBD Tolling
LES - Traffic Flowmap
MD Existing



- Legend:**
- 1 - Intersection (2019 Collected Data)
 - 7 - Intersection (Uncollected Data)
 - 100 - ATR Volume
 - 100 - Approach Volume

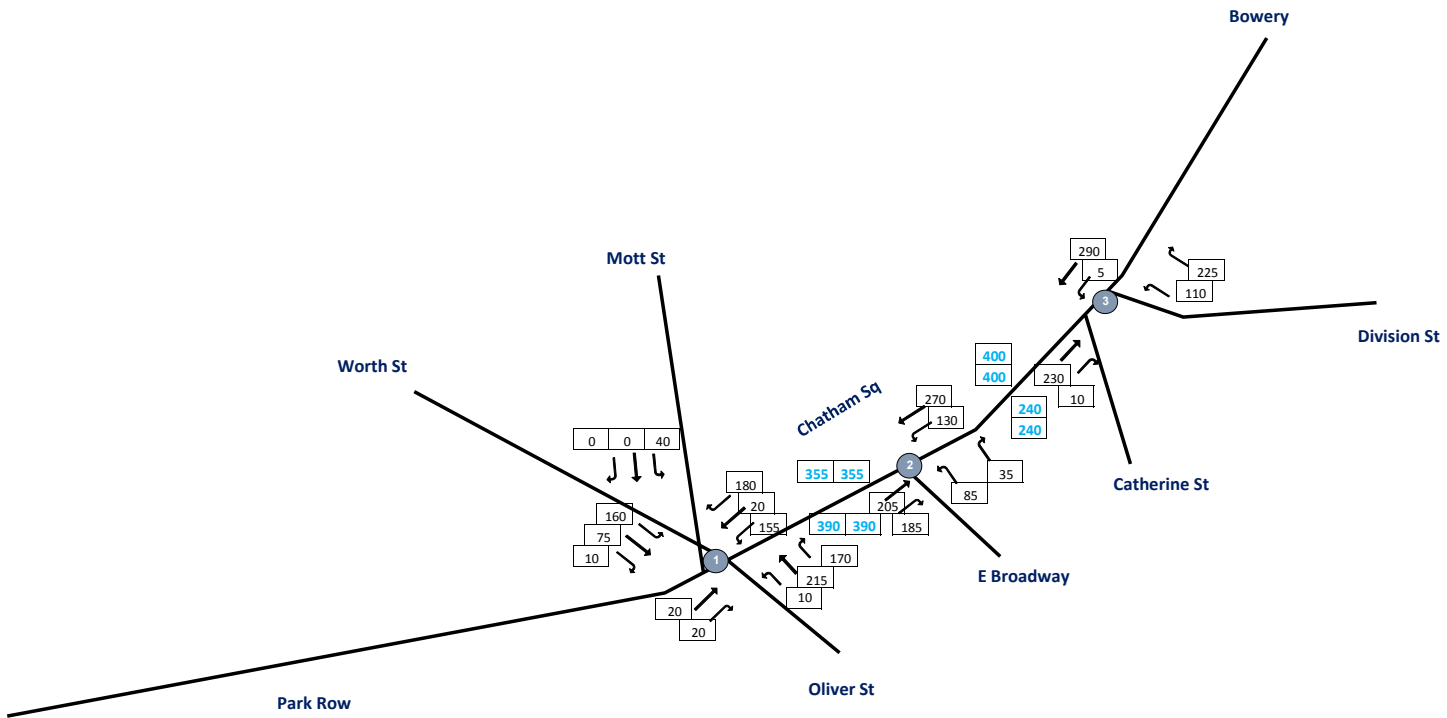

LES

1:00 PM

Intersection	Node	Approach	Total Vehicles					
			Inbound/Outbound					
			MD Peak Hour					
			L2	L	T	R	R2	Total
Worth St/Oliver St/Mott St & Chatham Square/Park Row 2022 (LES-01)								
Mott St	1	SW	40	0	0	0	0	
Park Row	1	EB	0	0	20	20	0	
Chatham Sq	1	WB	0	155	20	180	0	
Oliver St	1	NB	0	10	215	0	170	
Worth St	1	SB	0	160	75	10	0	1075
E Broadway & Chatham Sq 2022 (LES-02)								
Chatham Sq	2	EB	0	0	205	185	0	
Chatham Sq	2	WB	0	130	270	0	0	
E Broadway	2	NB	0	85	0	35	0	
	2	SB	0	0	0	0	0	910
Division St/Doyers St/Catherine St & Chatham Square/Bowery 2022 (LES-03)								
Chatham Sq	3	EB	0	0	230	0	10	
Bowery	3	WB	0	5	290	0	0	
Division St	3	NB	0	110	0	225	0	
	3	SB	0	0	0	0	0	870

CBD Tolling
LES - Traffic Flowmap
PM Existing



- Legend:**
- 1 - Intersection (2019 Collected Data)
 - 7 - Intersection (Uncollected Data)
 - 100 - ATR Volume
 - 100 - Approach Volume

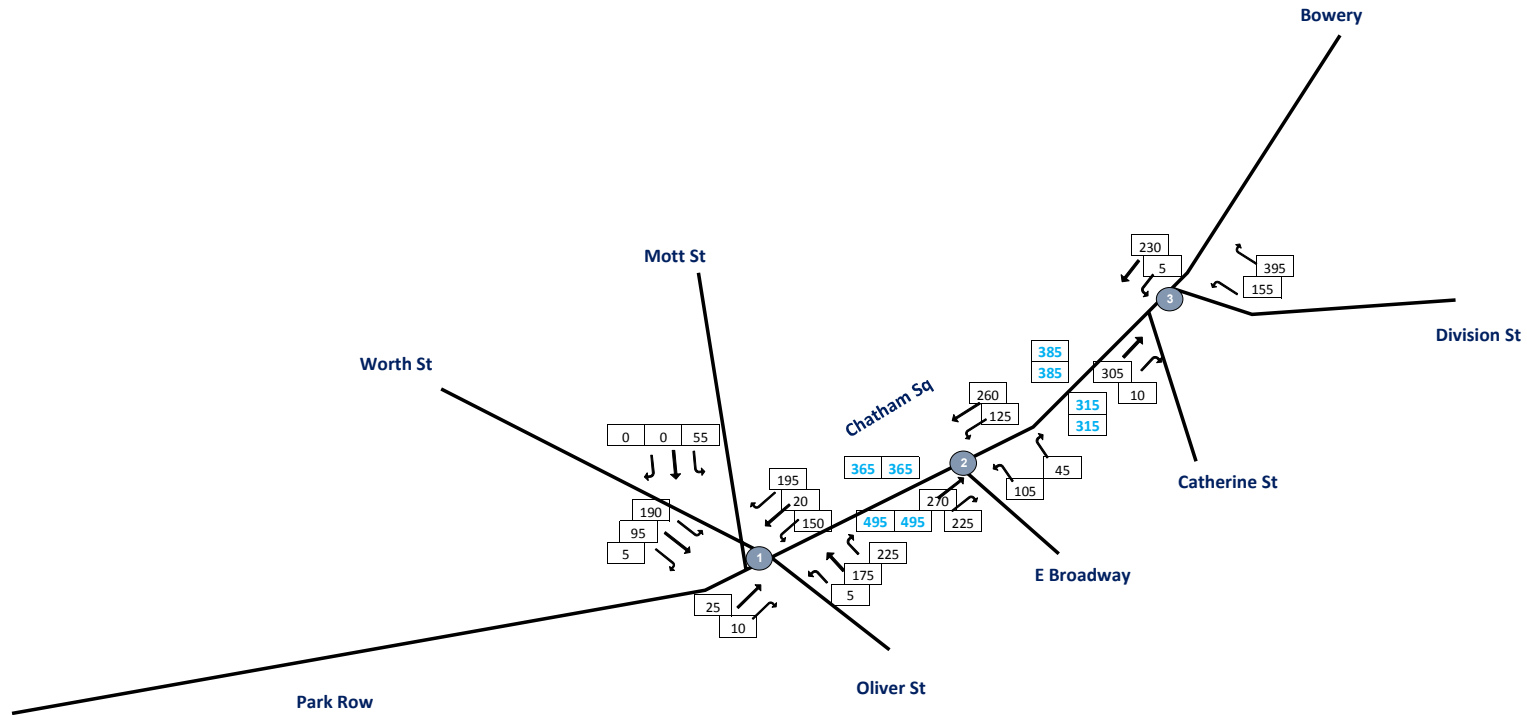

LES

5:00 PM

Intersection	Node	Approach	Total Vehicles					
			Inbound/Outbound					
			PM Peak Hour					
			L2	L	T	R	R2	Total
Worth St/Oliver St/Mott St & Chatham Square/Park Row								
2022 (LES-01)	1							
Mott St	1	SW	55	0	0	0	0	
Park Row	1	EB	0	0	25	10	0	
Chatham Sq	1	WB	0	150	20	195	0	
Oliver St	1	NB	0	5	175	0	225	
Worth St	1	SB	0	190	95	5	0	1150
E Broadway & Chatham Sq								
2022 (LES-02)	2							
Chatham Sq	2	EB	0	0	270	225	0	
Chatham Sq	2	WB	0	125	260	0	0	
E Broadway	2	NB	0	105	0	45	0	
	2	SB	0	0	0	0	0	1030
Division St/Doyers St/Catherine St & Chatham Square/Bowery								
2022 (LES-03)	3							
Chatham Sq	3	EB	0	0	305	0	10	
Bowery	3	WB	0	5	230	0	0	
Division St	3	NB	0	155	0	395	0	
	3	SB	0	0	0	0	0	1100

CBD Tolling
LES - Traffic Flowmap
AM No-Action Increment



- Legend:**
- 1 - Intersection (2019 Collected Data)
 - 7 - Intersection (Uncollected Data)
 - 100 - ATR Volume
 - 100 - Approach Volume

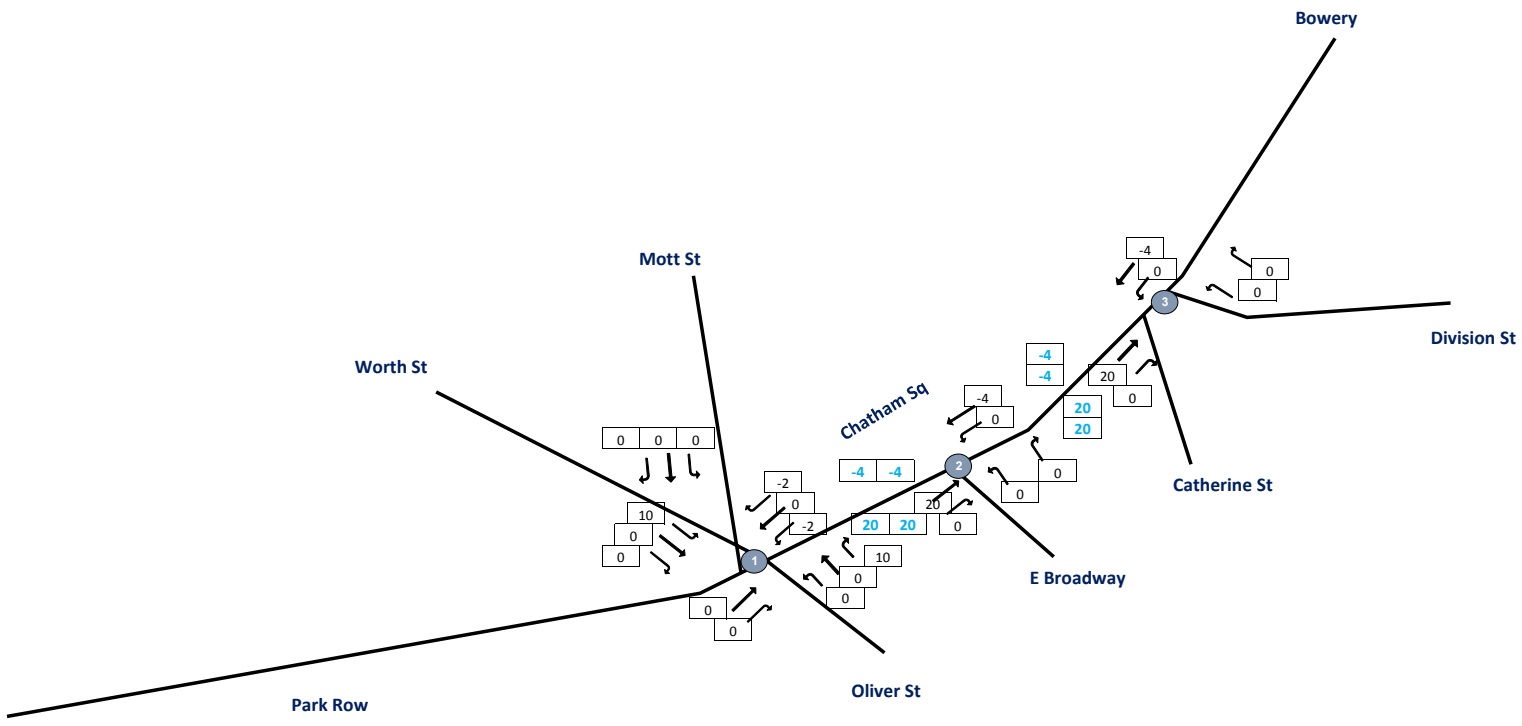

LES

8:00 AM

Intersection	Node	Approach	Total Vehicles						
			Inbound/Outbound						
			AM Peak Hour						
			L2	L	T	R	R2	Total	
Worth St/Oliver St/Mott St & Chatham Square/Park Row 2022 (LES-01)									
Mott St	1	SW	0	0	0	0	0		
Park Row	1	EB	0	0	0	0	0		
Chatham Sq	1	WB	0	-2	0	-2	0		
Oliver St	1	NB	0	0	0	0	10		
Worth St	1	SB	0	10	0	0	0	16	
E Broadway & Chatham Sq 2022 (LES-02)									
Chatham Sq	2	EB	0	0	20	0	0		
Chatham Sq	2	WB	0	0	-4	0	0		
E Broadway	2	NB	0	0	0	0	0		
	2	SB	0	0	0	0	0	16	
Division St/Doyers St/Catherine St & Chatham Square/Bowery 2022 (LES-03)									
Chatham Sq	3	EB	0	0	20	0	0		
Bowery	3	WB	0	0	-4	0	0		
Division St	3	NB	0	0	0	0	0		
	3	SB	0	0	0	0	0	16	

CBD Tolling
LES - Traffic Flowmap
AM No Action



- Legend:**
- 1 - Intersection (2019 Collected Data)
 - 7 - Intersection (Uncollected Data)
 - 100 - ATR Volume
 - 100 - Approach Volume

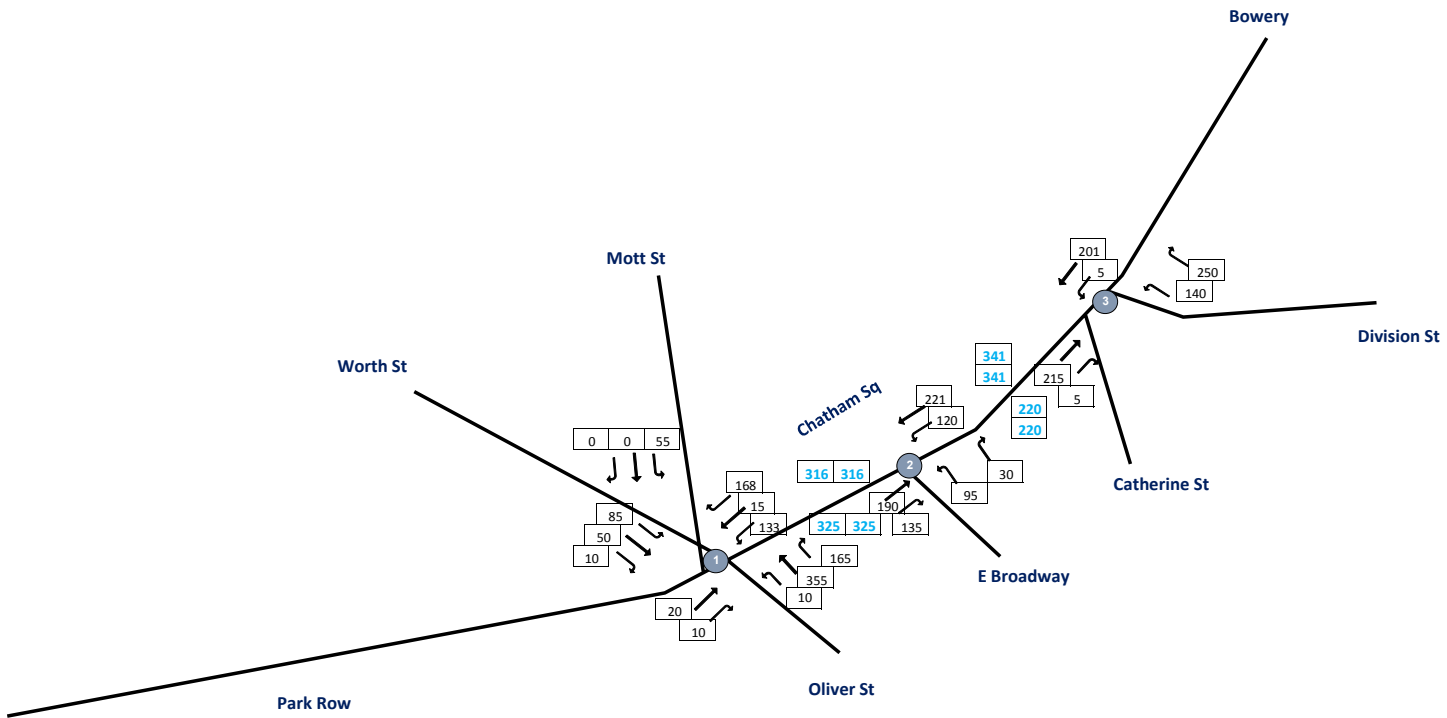

LES

8:00 AM

Intersection	Node	Approach	Total Vehicles					
			Inbound/Outbound					Total
			AM Peak Hour					
L2	L	T	R	R2				
Worth St/Oliver St/Mott St & Chatham Square/Park Row								
2022 (LES-01)	1							
Mott St	1	SW	55	0	0	0	0	
Park Row	1	EB	0	0	20	10	0	
Chatham Sq	1	WB	0	133	15	168	0	
Oliver St	1	NB	0	10	355	0	165	
Worth St	1	SB	0	85	50	10	0	
							1076	
E Broadway & Chatham Sq								
2022 (LES-02)	2							
Chatham Sq	2	EB	0	0	190	135	0	
Chatham Sq	2	WB	0	120	221	0	0	
E Broadway	2	NB	0	95	0	30	0	
	2	SB	0	0	0	0	0	
							791	
Division St/Doyers St/Catherine St & Chatham Square/Bowery								
2022 (LES-03)	3							
Chatham Sq	3	EB	0	0	215	0	5	
Bowery	3	WB	0	5	201	0	0	
Division St	3	NB	0	140	0	250	0	
	3	SB	0	0	0	0	0	
							816	

CBD Tolling
LES - Traffic Flowmap
MD No-Action Increment



- Legend:**
- 1 - Intersection (2019 Collected Data)
 - 7 - Intersection (Uncollected Data)
 - 100 - ATR Volume
 - 100 - Approach Volume

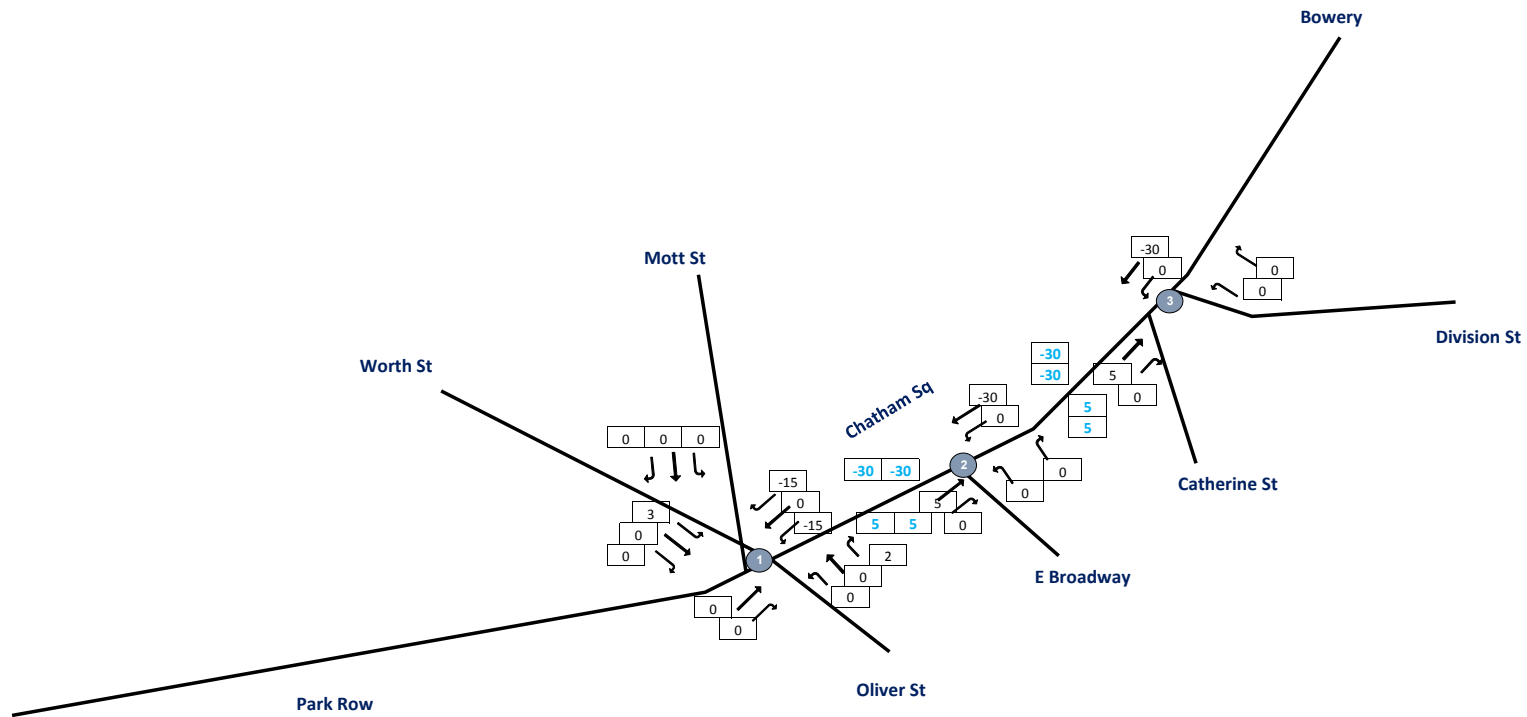

LES

1:00 PM

Intersection	Node	Approach	Total Vehicles					
			Inbound/Outbound					
			MD Peak Hour					
			L2	L	T	R	R2	Total
Worth St/Oliver St/Mott St & Chatham Square/Park Row 2022 (LES-01)								
Mott St	1	SW	0	0	0	0	0	
Park Row	1	EB	0	0	0	0	0	
Chatham Sq	1	WB	0	-15	0	-15	0	
Oliver St	1	NB	0	0	0	0	2	
Worth St	1	SB	0	3	0	0	0	-25
E Broadway & Chatham Sq 2022 (LES-02)								
Chatham Sq	2	EB	0	0	5	0	0	
Chatham Sq	2	WB	0	0	-30	0	0	
E Broadway	2	NB	0	0	0	0	0	
	2	SB	0	0	0	0	0	-25
Division St/Doyers St/Catherine St & Chatham Square/Bowery 2022 (LES-03)								
Chatham Sq	3	EB	0	0	5	0	0	
Bowery	3	WB	0	0	-30	0	0	
Division St	3	NB	0	0	0	0	0	
	3	SB	0	0	0	0	0	-25

CBD Tolling
LES - Traffic Flowmap
MD No Action



- Legend:**
- 1 - Intersection (2019 Collected Data)
 - 7 - Intersection (Uncollected Data)
 - 100 - ATR Volume
 - 100 - Approach Volume

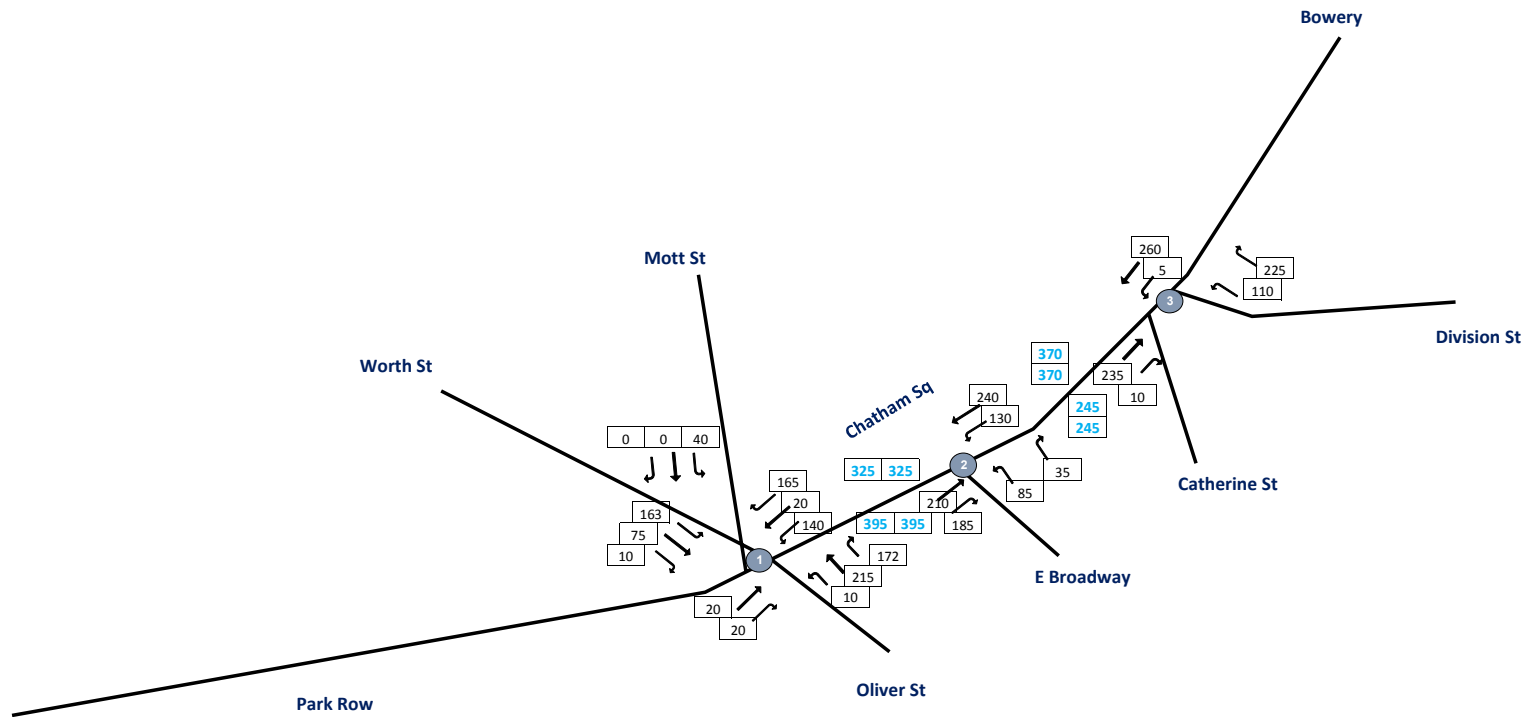

LES

1:00 PM

Intersection	Node	Approach	Total Vehicles					
			Inbound/Outbound					
			MD Peak Hour					
			L2	L	T	R	R2	Total
Worth St/Oliver St/Mott St & Chatham Square/Park Row 2022 (LES-01)								
Mott St	1	SW	40	0	0	0	0	
Park Row	1	EB	0	0	20	20	0	
Chatham Sq	1	WB	0	140	20	165	0	
Oliver St	1	NB	0	10	215	0	172	
Worth St	1	SB	0	163	75	10	0	1050
E Broadway & Chatham Sq 2022 (LES-02)								
Chatham Sq	2	EB	0	0	210	185	0	
Chatham Sq	2	WB	0	130	240	0	0	
E Broadway	2	NB	0	85	0	35	0	
	2	SB	0	0	0	0	0	885
Division St/Doyers St/Catherine St & Chatham Square/Bowery 2022 (LES-03)								
Chatham Sq	3	EB	0	0	235	0	10	
Bowery	3	WB	0	5	260	0	0	
Division St	3	NB	0	110	0	225	0	
	3	SB	0	0	0	0	0	845

CBD Tolling
LES - Traffic Flowmap
PM No-Action Increment



- Legend:**
- 1 - Intersection (2019 Collected Data)
 - 7 - Intersection (Uncollected Data)
 - 100 - ATR Volume
 - 100 - Approach Volume

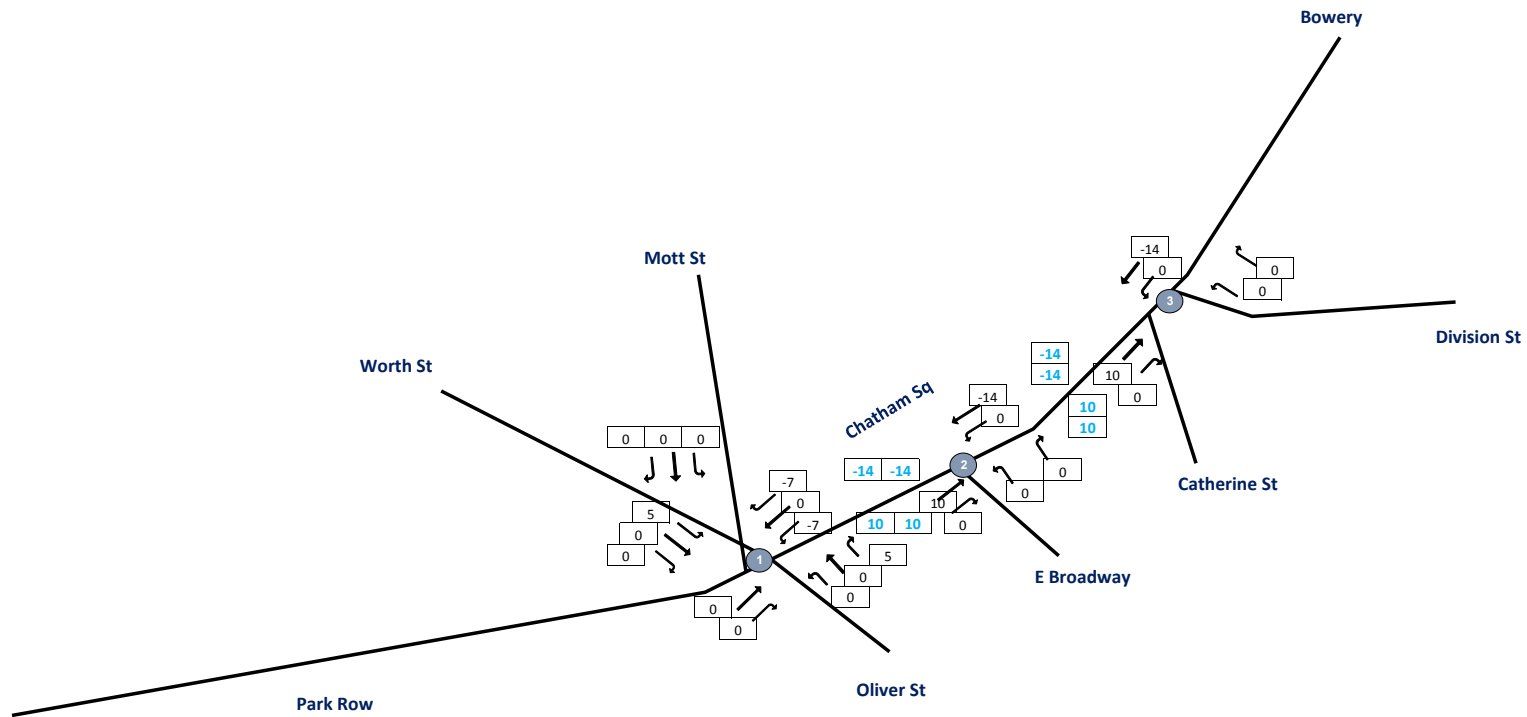

LES

5:00 PM

Intersection	Node	Approach	Total Vehicles					
			Inbound/Outbound					
			PM Peak Hour					
			L2	L	T	R	R2	Total
Worth St/Oliver St/Mott St & Chatham Square/Park Row								
2022 (LES-01)	1							
Mott St	1	SW	0	0	0	0	0	
Park Row	1	EB	0	0	0	0	0	
Chatham Sq	1	WB	0	-7	0	-7	0	
Oliver St	1	NB	0	0	0	0	5	
Worth St	1	SB	0	5	0	0	0	-4
E Broadway & Chatham Sq								
2022 (LES-02)	2							
Chatham Sq	2	EB	0	0	10	0	0	
Chatham Sq	2	WB	0	0	-14	0	0	
E Broadway	2	NB	0	0	0	0	0	
	2	SB	0	0	0	0	0	-4
Division St/Doyers St/Catherine St & Chatham Square/Bowery								
2022 (LES-03)	3							
Chatham Sq	3	EB	0	0	10	0	0	
Bowery	3	WB	0	0	-14	0	0	
Division St	3	NB	0	0	0	0	0	
	3	SB	0	0	0	0	0	-4

CBD Tolling
LES - Traffic Flowmap
PM No Action



- Legend:**
- 1 - Intersection (2019 Collected Data)
 - 7 - Intersection (Uncollected Data)
 - 100 - ATR Volume
 - 100 - Approach Volume

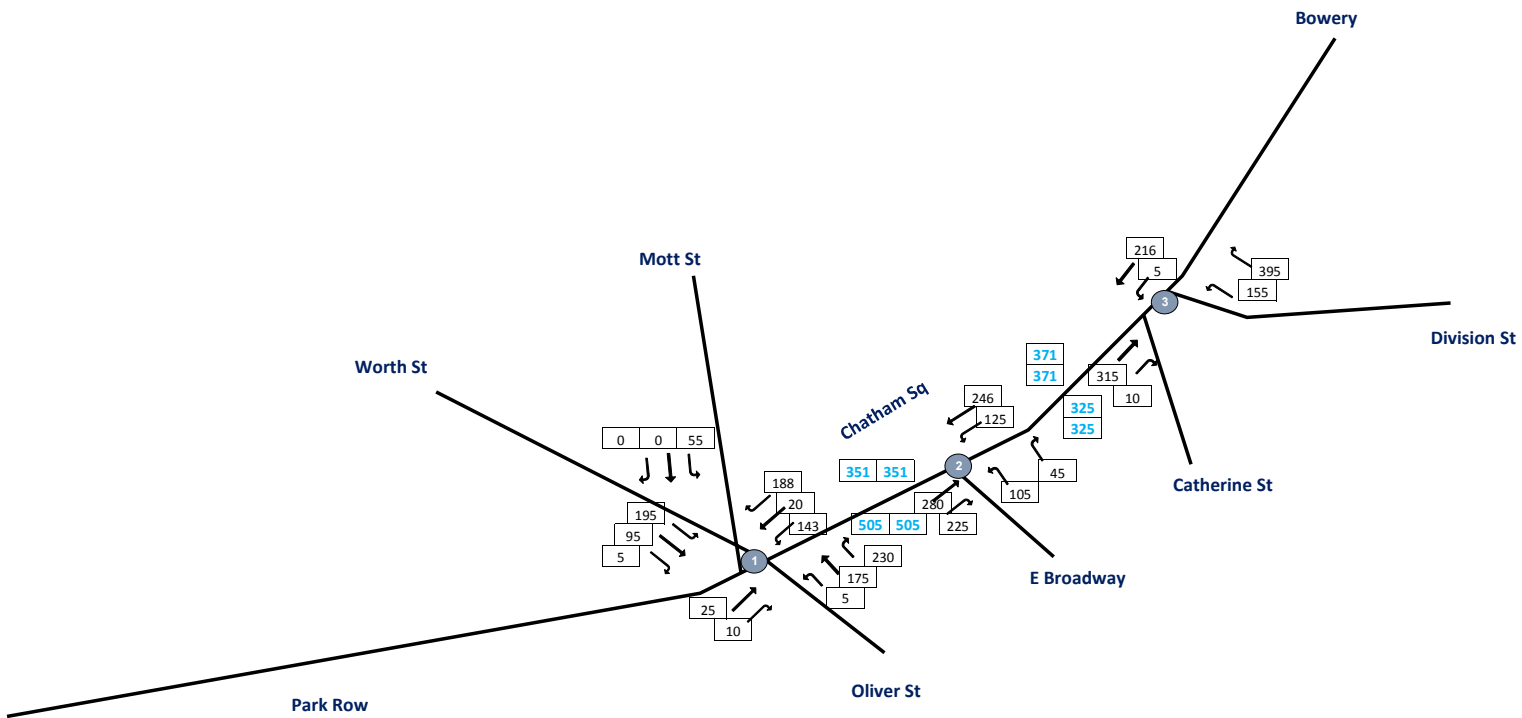

LES

5:00 PM

Intersection	Node	Approach	Total Vehicles					
			Inbound/Outbound					Total
			PM Peak Hour					
L2	L	T	R	R2				
Worth St/Oliver St/Mott St & Chatham Square/Park Row 2022 (LES-01)								
Mott St	1	SW	55	0	0	0	0	
Park Row	1	EB	0	0	25	10	0	
Chatham Sq	1	WB	0	143	20	188	0	
Oliver St	1	NB	0	5	175	0	230	
Worth St	1	SB	0	195	95	5	0	1146
E Broadway & Chatham Sq 2022 (LES-02)								
Chatham Sq	2	EB	0	0	280	225	0	
Chatham Sq	2	WB	0	125	246	0	0	
E Broadway	2	NB	0	105	0	45	0	
	2	SB	0	0	0	0	0	1026
Division St/Doyers St/Catherine St & Chatham Square/Bowery 2022 (LES-03)								
Chatham Sq	3	EB	0	0	315	0	10	
Bowery	3	WB	0	5	216	0	0	
Division St	3	NB	0	155	0	395	0	
	3	SB	0	0	0	0	0	1096

CBD Tolling
LES - Traffic Flowmap
AM With-Action Increment



- Legend:**
- 1 - Intersection (2019 Collected Data)
 - 7 - Intersection (Uncollected Data)
 - 100 - ATR Volume
 - 100 - Approach Volume

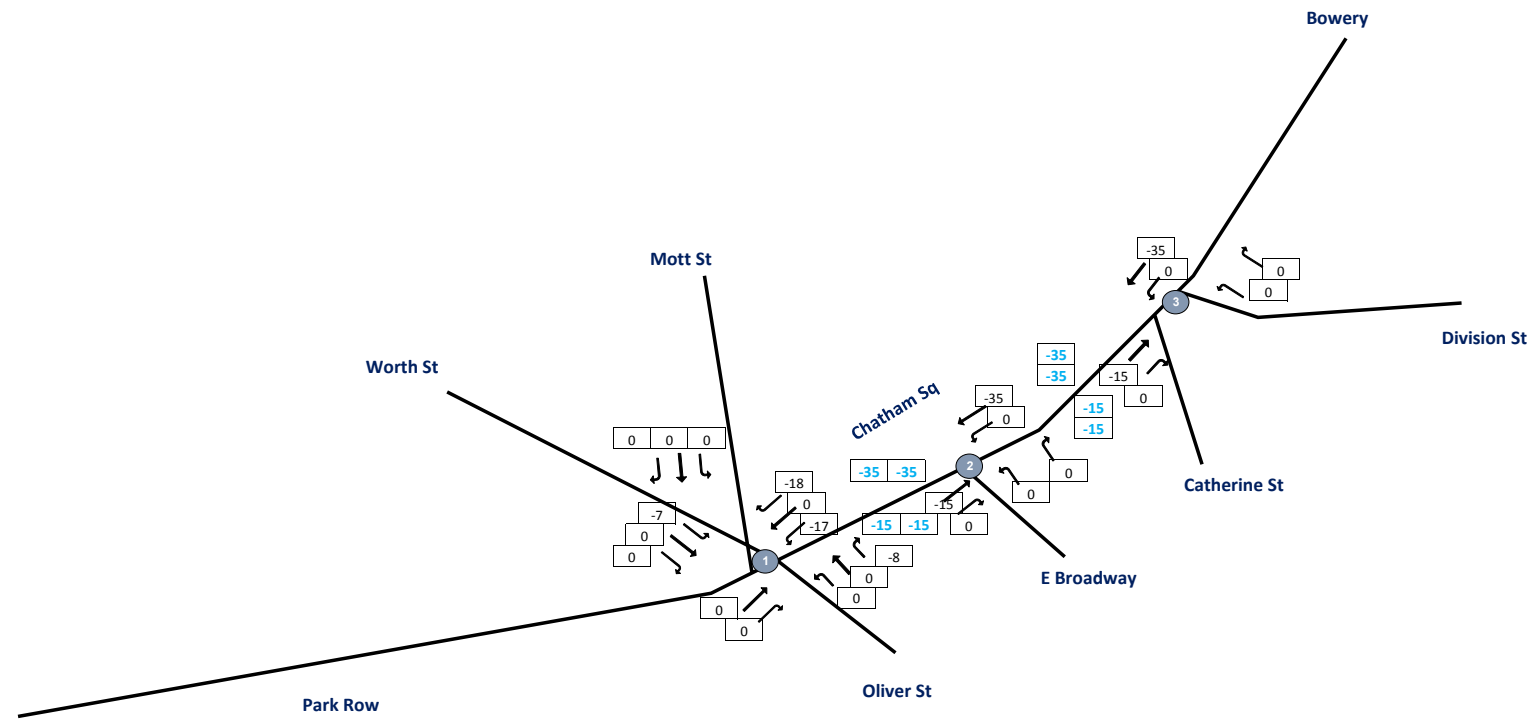

LES

8:00 AM

Intersection	Node	Approach	Total Vehicles					
			Inbound/Outbound					
			AM Peak Hour					
			L2	L	T	R	R2	Total
Worth St/Oliver St/Mott St & Chatham Square/Park Row								
2022 (LES-01)	1							
Mott St	1	SW	0	0	0	0	0	
Park Row	1	EB	0	0	0	0	0	
Chatham Sq	1	WB	0	-17	0	-18	0	
Oliver St	1	NB	0	0	0	0	-8	
Worth St	1	SB	0	-7	0	0	0	-50
E Broadway & Chatham Sq								
2022 (LES-02)	2							
Chatham Sq	2	EB	0	0	-15	0	0	
Chatham Sq	2	WB	0	0	-35	0	0	
E Broadway	2	NB	0	0	0	0	0	
	2	SB	0	0	0	0	0	-50
Division St/Doyers St/Catherine St & Chatham Square/Bowery								
2022 (LES-03)	3							
Chatham Sq	3	EB	0	0	-15	0	0	
Bowery	3	WB	0	0	-35	0	0	
Division St	3	NB	0	0	0	0	0	
	3	SB	0	0	0	0	0	-50

CBD Tolling
LES - Traffic Flowmap
AM With-Action



- Legend:**
- 1 - Intersection (2019 Collected Data)
 - 7 - Intersection (Uncollected Data)
 - 100 - ATR Volume
 - 100 - Approach Volume

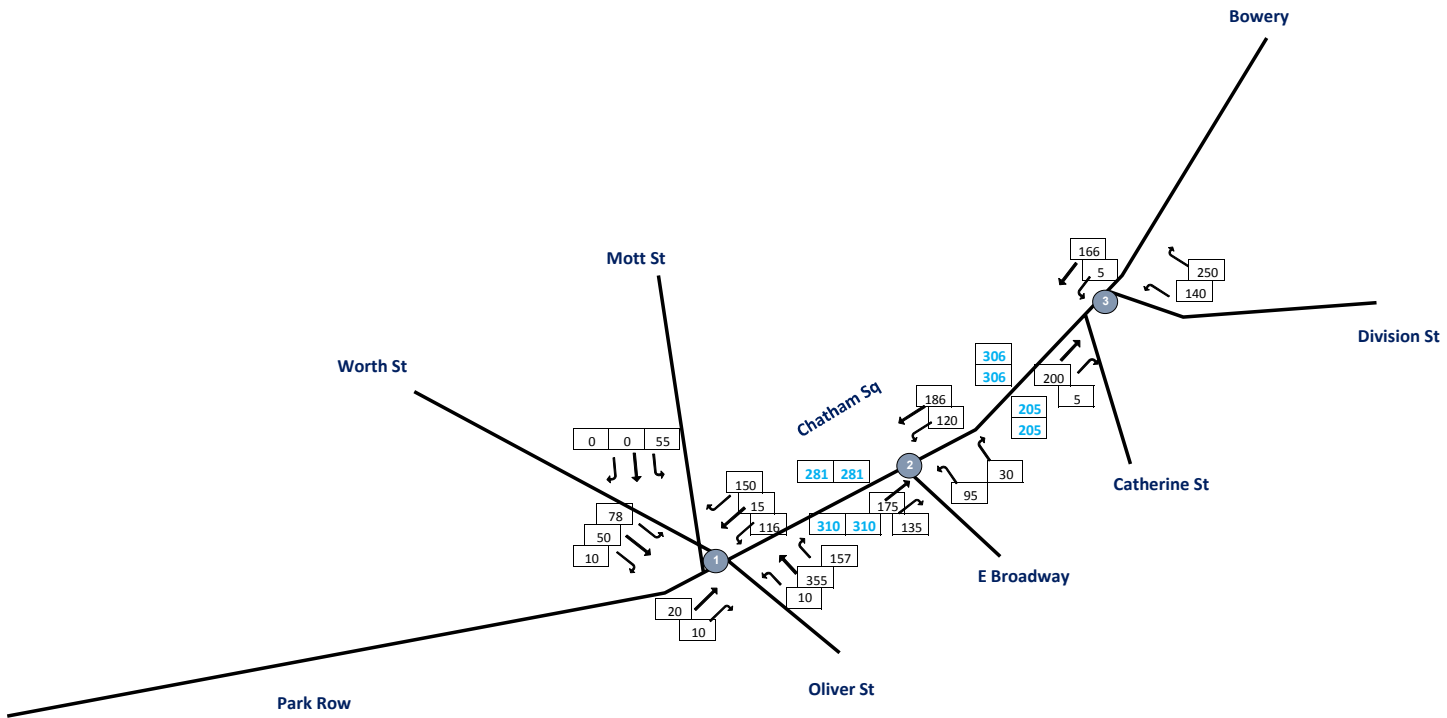

LES

8:00 AM

Intersection	Node	Approach	Total Vehicles					
			Inbound/Outbound					
			AM Peak Hour					
			L2	L	T	R	R2	Total
Worth St/Oliver St/Mott St & Chatham Square/Park Row								
2022 (LES-01)	1							
Mott St	1	SW	55	0	0	0	0	
Park Row	1	EB	0	0	20	10	0	
Chatham Sq	1	WB	0	116	15	150	0	
Oliver St	1	NB	0	10	355	0	157	
Worth St	1	SB	0	78	50	10	0	1026
E Broadway & Chatham Sq								
2022 (LES-02)	2							
Chatham Sq	2	EB	0	0	175	135	0	
Chatham Sq	2	WB	0	120	186	0	0	
E Broadway	2	NB	0	95	0	30	0	
	2	SB	0	0	0	0	0	741
Division St/Doyers St/Catherine St & Chatham Square/Bowery								
2022 (LES-03)	3							
Chatham Sq	3	EB	0	0	200	0	5	
Bowery	3	WB	0	5	166	0	0	
Division St	3	NB	0	140	0	250	0	
	3	SB	0	0	0	0	0	766

CBD Tolling
LES - Traffic Flowmap
MD With-Action Increment



- Legend:**
- ① - Intersection (2019 Collected Data)
 - ⑦ - Intersection (Uncollected Data)
 - 100 - ATR Volume
 - 100 - Approach Volume

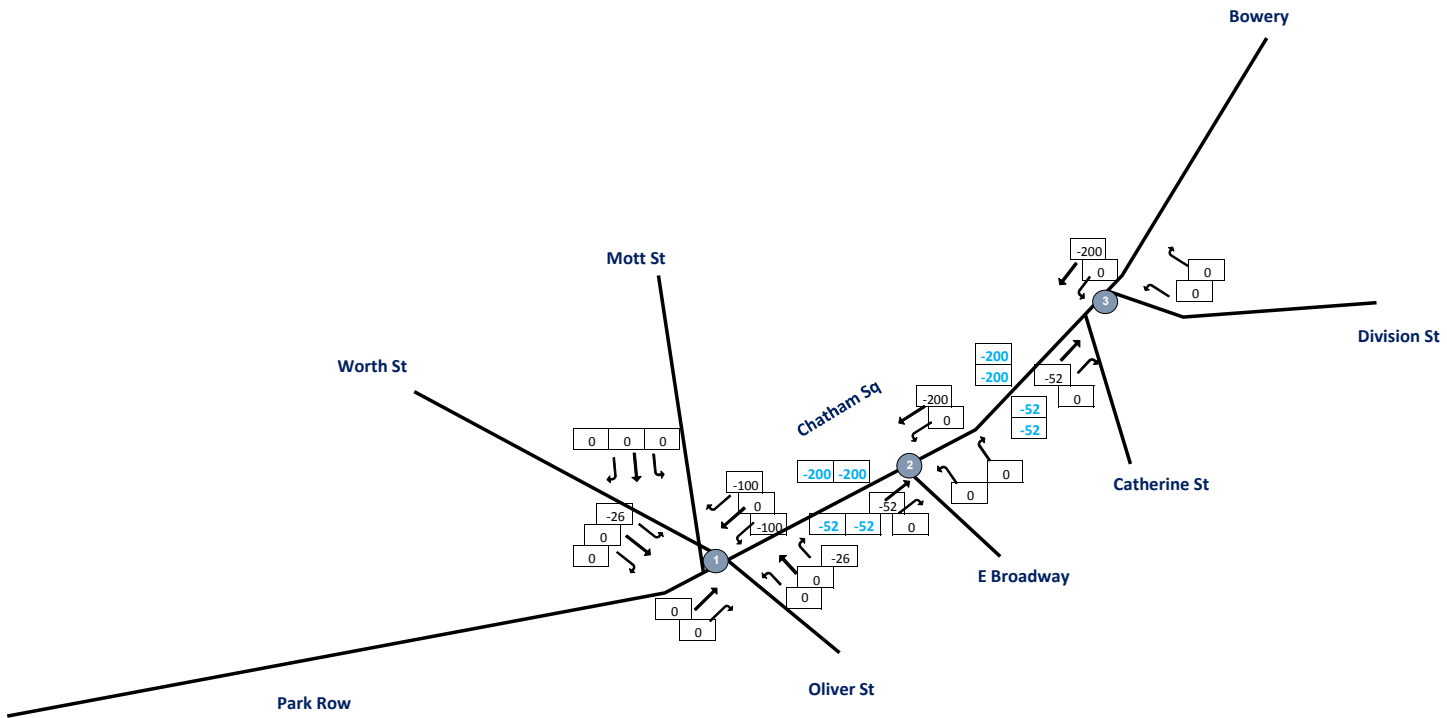

LES

1:00 PM

Intersection	Node	Approach	Total Vehicles					
			Inbound/Outbound					
			MD Peak Hour					
			L2	L	T	R	R2	Total
Worth St/Oliver St/Mott St & Chatham Square/Park Row								
2022 (LES-01)	1							
Mott St	1	SW	0	0	0	0	0	
Park Row	1	EB	0	0	0	0	0	
Chatham Sq	1	WB	0	-100	0	-100	0	
Oliver St	1	NB	0	0	0	0	-26	
Worth St	1	SB	0	-26	0	0	0	-252
E Broadway & Chatham Sq								
2022 (LES-02)	2							
Chatham Sq	2	EB	0	0	-52	0	0	
Chatham Sq	2	WB	0	0	-200	0	0	
E Broadway	2	NB	0	0	0	0	0	
	2	SB	0	0	0	0	0	-252
Division St/Doyers St/Catherine St & Chatham Square/Bowery								
2022 (LES-03)	3							
Chatham Sq	3	EB	0	0	-52	0	0	
Bowery	3	WB	0	0	-200	0	0	
Division St	3	NB	0	0	0	0	0	
	3	SB	0	0	0	0	0	-252

CBD Tolling
LES - Traffic Flowmap
MD No Action



- Legend:**
- 1 - Intersection (2019 Collected Data)
 - 7 - Intersection (Uncollected Data)
 - 100 - ATR Volume
 - 100 - Approach Volume

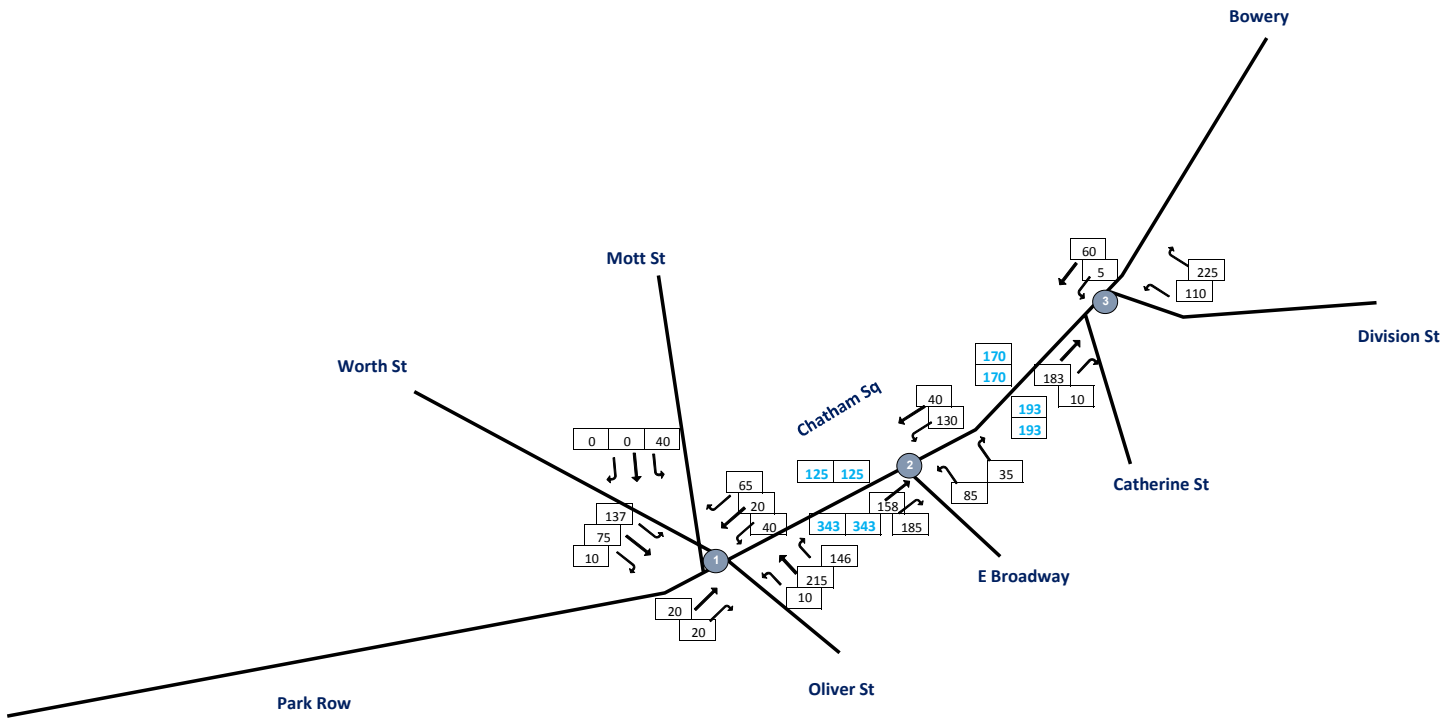

LES

1:00 PM

Intersection	Node	Approach	Total Vehicles					
			Inbound/Outbound					
			MD Peak Hour					
			L2	L	T	R	R2	Total
Worth St/Oliver St/Mott St & Chatham Square/Park Row 2022 (LES-01)								
Mott St	1	SW	40	0	0	0	0	
Park Row	1	EB	0	0	20	20	0	
Chatham Sq	1	WB	0	40	20	65	0	
Oliver St	1	NB	0	10	215	0	146	
Worth St	1	SB	0	137	75	10	0	798
E Broadway & Chatham Sq 2022 (LES-02)								
Chatham Sq	2	EB	0	0	158	185	0	
Chatham Sq	2	WB	0	130	40	0	0	
E Broadway	2	NB	0	85	0	35	0	
	2	SB	0	0	0	0	0	633
Division St/Doyers St/Catherine St & Chatham Square/Bowery 2022 (LES-03)								
Chatham Sq	3	EB	0	0	183	0	10	
Bowery	3	WB	0	5	60	0	0	
Division St	3	NB	0	110	0	225	0	
	3	SB	0	0	0	0	0	593

CBD Tolling
LES - Traffic Flowmap
PM With-Action Increment



- Legend:**
- 1 - Intersection (2019 Collected Data)
 - 7 - Intersection (Uncollected Data)
 - 100 - ATR Volume
 - 100 - Approach Volume

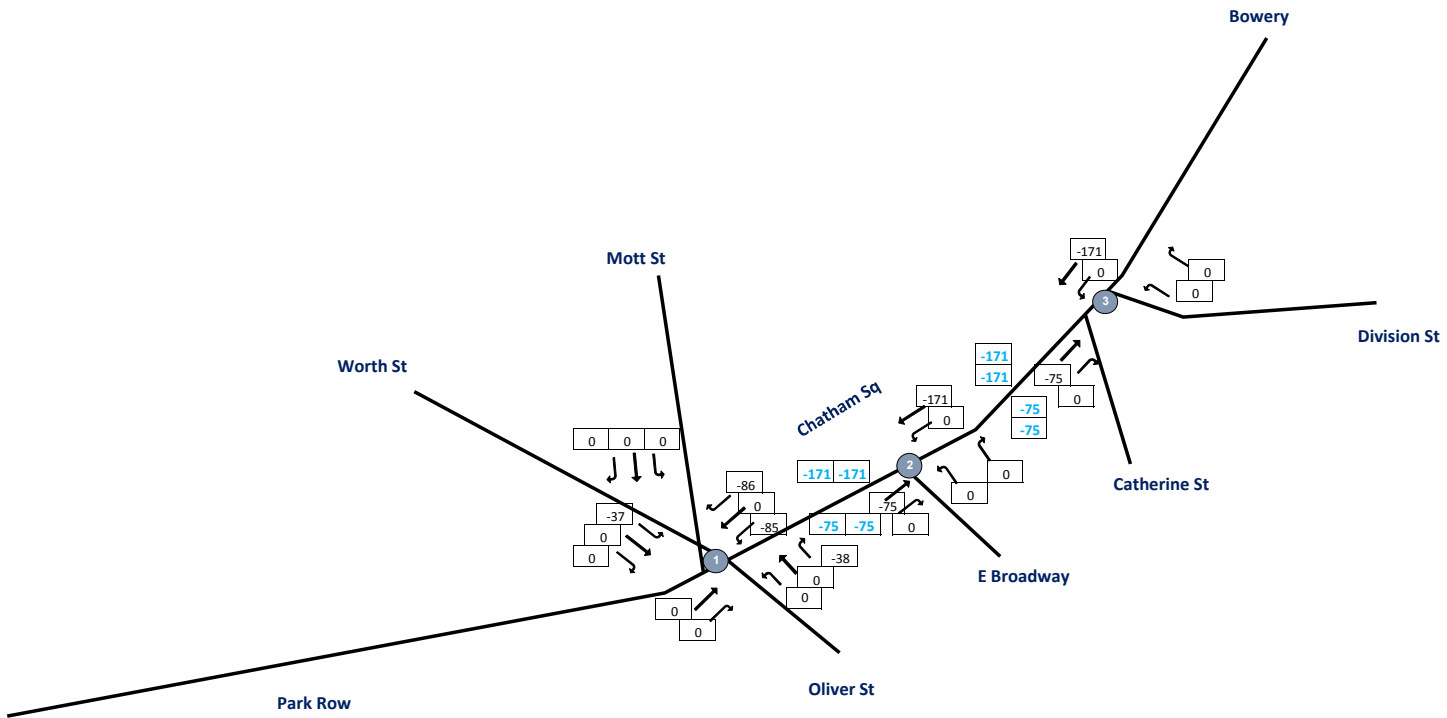

LES

5:00 PM

Intersection	Node	Approach	Total Vehicles					
			Inbound/Outbound					
			PM Peak Hour					
			L2	L	T	R	R2	Total
Worth St/Oliver St/Mott St & Chatham Square/Park Row								
2022 (LES-01)	1							
Mott St	1	SW	0	0	0	0	0	
Park Row	1	EB	0	0	0	0	0	
Chatham Sq	1	WB	0	-85	0	-86	0	
Oliver St	1	NB	0	0	0	0	-38	
Worth St	1	SB	0	-37	0	0	0	-246
E Broadway & Chatham Sq								
2022 (LES-02)	2							
Chatham Sq	2	EB	0	0	-75	0	0	
Chatham Sq	2	WB	0	0	-171	0	0	
E Broadway	2	NB	0	0	0	0	0	
	2	SB	0	0	0	0	0	-246
Division St/Doyers St/Catherine St & Chatham Square/Bowery								
2022 (LES-03)	3							
Chatham Sq	3	EB	0	0	-75	0	0	
Bowery	3	WB	0	0	-171	0	0	
Division St	3	NB	0	0	0	0	0	
	3	SB	0	0	0	0	0	-246

CBD Tolling
LES - Traffic Flowmap
PM With-Action



- Legend:**
- 1 - Intersection (2019 Collected Data)
 - 7 - Intersection (Uncollected Data)
 - 100 - ATR Volume
 - 100 - Approach Volume

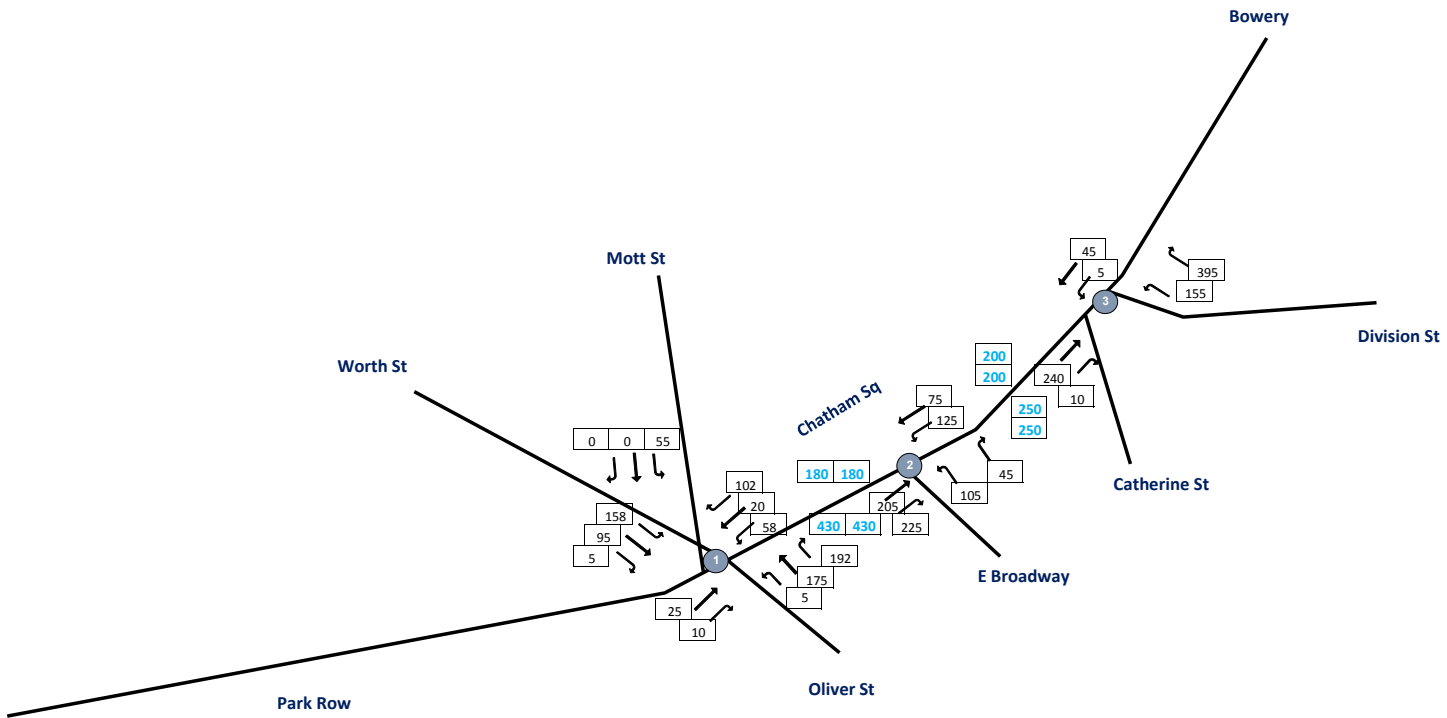

LES

5:00 PM

Intersection	Node	Approach	Total Vehicles					
			Inbound/Outbound					
			PM Peak Hour					
			L2	L	T	R	R2	Total
Worth St/Oliver St/Mott St & Chatham Square/Park Row 2022 (LES-01)								
Mott St	1	SW	55	0	0	0	0	
Park Row	1	EB	0	0	25	10	0	
Chatham Sq	1	WB	0	58	20	102	0	
Oliver St	1	NB	0	5	175	0	192	
Worth St	1	SB	0	158	95	5	0	900
E Broadway & Chatham Sq 2022 (LES-02)								
Chatham Sq	2	EB	0	0	205	225	0	
Chatham Sq	2	WB	0	125	75	0	0	
E Broadway	2	NB	0	105	0	45	0	
	2	SB	0	0	0	0	0	780
Division St/Doyers St/Catherine St & Chatham Square/Bowery 2022 (LES-03)								
Chatham Sq	3	EB	0	0	240	0	10	
Bowery	3	WB	0	5	45	0	0	
Division St	3	NB	0	155	0	395	0	
	3	SB	0	0	0	0	0	850